

Ultra-Low Pressure Digital Sensor

SM9541 Series



Features

- Fully digital, pressure calibrated and temperature compensated output
- I²C Digital Interface
- Compensated temperature range: -5 to 65°C
- Compound gage and differential pressure configurations
- Insensitive to mounting orientation
- Robust JEDEC SOIC-16 package for automated assembly
- Manufactured according to ISO9001 and ISO/TS 16949 standards
- RoHS & REACH compliant
- Pressure ranges from 10 cm*H₂O to 100 cm*H₂O (0.15 to 1.5 PSI)

Description

The SM9541 Series is a digital, low pressure MEMS sensor family offering state-of-the-art pressure transducer technology and CMOS mixed signal processing technology to produce a digital, fully conditioned, multi-order pressure and temperature compensated sensor in JEDEC standard SOIC-16 package with a dual vertical porting option. It is available in both compound gage or differential pressure configurations. With the dual porting, a vacuum-gage measurement is possible to minimize altitude errors due to changes in ambient pressure.

Combining the pressure sensor with a signal-conditioning ASIC in a single package simplifies the use of advanced silicon micro-machined pressure sensors. The pressure sensor can be mounted directly on a standard printed circuit board and a high level, calibrated pressure signal can be acquired from the digital interface. This eliminates the need for additional circuitry, such as a compensation network or microcontroller containing a custom correction algorithm.

The SM9541 is shipped in sticks or tape & reel.

Potential Applications

Medical	Industrial	Consumer
Sleep Apnea	Airflow Measurement	Sports Equipment
CPAP	Pneumatic Gages	Appliances
Ventilators	Pressure Switches	
Oxygenators	Safety Cabinets	
Negative Pressure Wound Therapy	Life Sciences	
Air Flow Monitors	Gas Flow Instrumentation	
Gas Flow Instrumentation	Liquid Level Measurement	

Absolute Maximum Ratings

All parameters are specified at $V_{SUPPLY} = 3.3$ V DC supply at room temperature, unless otherwise noted.

No.	Characteristic	Symbol	Minimum	Typical	Maximum	Units
1	Excitation Voltage	V_{SUPPLY}	0.0		6.0	V
2	Excitation Current	I_{SUPPLY}	0.0	1.0	4.0	mA
3	Update Period				2	mS
4	Proof Pressure ^(a)	P_{PROOF}			3x	FS
5	Burst Pressure ^(a)	P_{BURST}			5x	FS
6	Operating Temperature ^(a)	T_{OP}	-5	32	+65	°C
7	Storage Temperature ^(a)	T_{STG}	-40	-	+125	°C
8	Media Compatibility ^(a,b)					

Notes:

a. Tested on a sample basis.

b. Clean, dry gas compatible with wetted materials. Wetted materials include Pyrex glass, silicon, alumina ceramic, epoxy, RTV, gold, aluminum, and nickel.

Operating Characteristics - Specifications

All parameters are specified at $V_{SUPPLY} = 3.3$ V DC supply at room temperature, unless otherwise noted.

Compound Gage						
No.	Characteristic	Symbol	Minimum	Typical	Maximum	Units
9	Supply Voltage	V_{VDD}	3.0	3.3	3.6	V FS
10	Negative FS Pressure Output @ P_{MAX}	-FSO		1,638		Counts
11	Positive FS Pressure Output @ P_{MAX}	+FSO		14,745		Counts
12	Full Scale (-0.5 to 10 cmH ₂ O) Span	FSP			10.5	cmH ₂ O
13	Full Scale (-1 to 20 cmH ₂ O) Span	FSP			21	cmH ₂ O
14	Full Scale (-5 to 40 cmH ₂ O) Span	FSP			45	cmH ₂ O
15	Full Scale (-5 to 100 cmH ₂ O) Span	FSP			105	cmH ₂ O
16	Resolution			14		Bits
17	Accuracy ^(c,d)	ACC_{RSS}			+/-1	%FS
18	Compensated Temperature Range	T_{COMP}	-5		65	°C

Notes:

c. Accuracy specifications apply over operating conditions. This specification represents the total combination of non-linearity, hysteresis, zero and span shift, repeatability & temperature effects.

d. Maximum 10-year zero shift = ±2%FS

Operating Characteristics - Specifications

All parameters are specified at $V_{SUPPLY} = 3.3$ V DC supply at room temperature, unless otherwise noted.

Differential ^(e)						
No.	Characteristic	Symbol	Minimum	Typical	Maximum	Units
19	Supply Voltage	V_{VDD}	3.0	3.3	3.6	V FS
20	Negative FS Pressure Output @ P_{MAX}	-FSO		1,638		Counts
21	Positive FS Pressure Output @ P_{MAX}	+FSO		14,745		Counts
22	Full Scale (-10 to 10 cmH ₂ O) Span	FSP			20	cmH ₂ O
23	Full Scale (-20 to 20 cmH ₂ O) Span	FSP			40	cmH ₂ O
24	Full Scale (-40 to 40 cmH ₂ O) Span	FSP			80	cmH ₂ O
25	Full Scale (-100 to 100 cmH ₂ O) Span	FSP			200	cmH ₂ O
26	Resolution			14		Bits
27	Accuracy ^(c,d)	ACC_{RSS}			+/-1	%FS
28	Compensated Temperature Range	T_{COMP}	-5		65	°C

Notes:

c. Accuracy specifications apply over operating conditions. This specification represents the total combination of non-linearity, hysteresis, zero and span shift, repeatability & temperature effects.

d. Maximum 10-year zero shift = $\pm 2\%$ FS

e. Preliminary specifications contingent upon final qualification of differential type.

Qualification Standards

- REACH Compliant
- RoHS Compliant
- PFOS/PFOA Compliant
- Qualified to meet AEC Q100 standards
- For qualification specifications, please contact Sales at sales@si-micro.com



SM9541 – I²C Communication

1. I²C Bit Rates

The SM9541 is set to a 4 MHz clock.

2. Slave Address

- The factory setting for the I²C slave address is 28HEX.
- Comm_lock is set and the part will only respond to the set address.

3. Read Operations

- For read operations, the I²C master command starts with the 7-bit slave address with the 8th bit = 1 (READ). The SM9541 as the slave sends an acknowledge (ACK) indicating success.
- The SM9541 has four I²C read commands: Read_MR, Read_DF2, Read_DF3, and Read_DF4. The following figures show the structure of the measurement packet for three of the four I²C read commands, which are further explained below.

3.1 I²C Read_MR (Measurement Request):

- **Note: The SM9541 is factory programmed to UPDATE Mode (not SLEEP Mode).** This measurement request is not needed to “wake up” the device, but is listed for completeness.
- The Read_MR communication contains only the slave address and the READ bit (1) sent by the master. After the SM9541 responds with the slave ACK, the master must create a stop condition.
- This is only used in Sleep Mode to wake up the device and start a complete measurement cycle (including the special measurements) followed by the DSP calculations and writing the results to the digital output register.
- Note: The I²C Read_MR function can also be accomplished using the I²C Read_DF2 or Read_DF3 command and ignoring the “stale” data that will be returned.

3.2 I²C Read_DF (Data Fetch):

- For the Data Fetch commands, the number of data bytes returned by the SM9541 is determined by when the master sends the NACK and stop condition.
- For the Read_DF3 data fetch command (Data Fetch 3 Bytes), the SM9541 returns three bytes in response to the master sending the slave address and the READ bit (1): two bytes of bridge data with the two status bits as the MSBs and then 1 byte of temperature data (8-bit accuracy). After receiving the required number of data bytes, the master sends the NACK and stop condition to terminate the read operation.
- For the Read_DF4 command, the master delays sending the NACK and continues reading an additional final byte to acquire the full corrected 11-bit temperature measurement. In this case, the last 5 bits of the final byte of the packet are undetermined and should be masked off in the application.
- The Read_DF2 command is used if corrected temperature is not required. The master terminates the READ operation after the two bytes of bridge data.

• **I2C Read_MR – Measurement Request:**

- Slave starts a measurement and DSP calculation cycle.
- Start Condition – Device Slave Address [6:0] – Read/Write Bit (Read = 1) – Wait for Slave ACK – Stop Condition

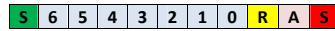

• **I2C Read_DF2 – Data Fetch 2 Bytes:**

- Slave returns only pressure data to the master in 2 bytes.
- Start Condition – Device Slave Address [6:0] – Read/Write Bit (Read = 1) – Wait for Slave ACK – 2 status bits – 6 pressure bits [13:8] – Master ACK – 8 pressure bits [7:0] – Master NACK – Stop Condition

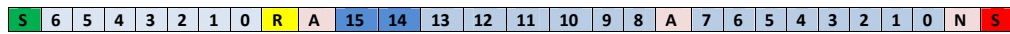

○ **I2C Read_DF3 – Data Fetch 3 Bytes:**

- Slave returns 2 pressure data bytes and temperature high byte [10:3] to the master.
- Start Condition – Device Slave Address [6:0] – Read/Write Bit (Read = 1) – Wait for Slave ACK – 2 status bits – 6 pressure bits [13:8] – Master ACK – 8 pressure bits [7:0] – Master ACK – 8 temperature bits [10:3] – Master NACK – Stop Condition

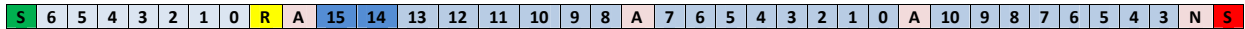

• **I2C Read_DF4 – Data Fetch 4 Bytes:**

- Slave returns 2 pressure data bytes and 2 temperature bytes ([10:3] and [2:0]xxxxx) to the master.
- Start Condition – Device Slave Address [6:0] – Read/Write Bit (Read = 1) – Wait for Slave ACK – 2 status bits – 6 pressure bits [13:8] – Master ACK – 8 pressure bits [7:0] – Master ACK – 8 temperature bits [10:3] – Master ACK – 3 temperature bits [3:0] – Master NACK – Stop Condition

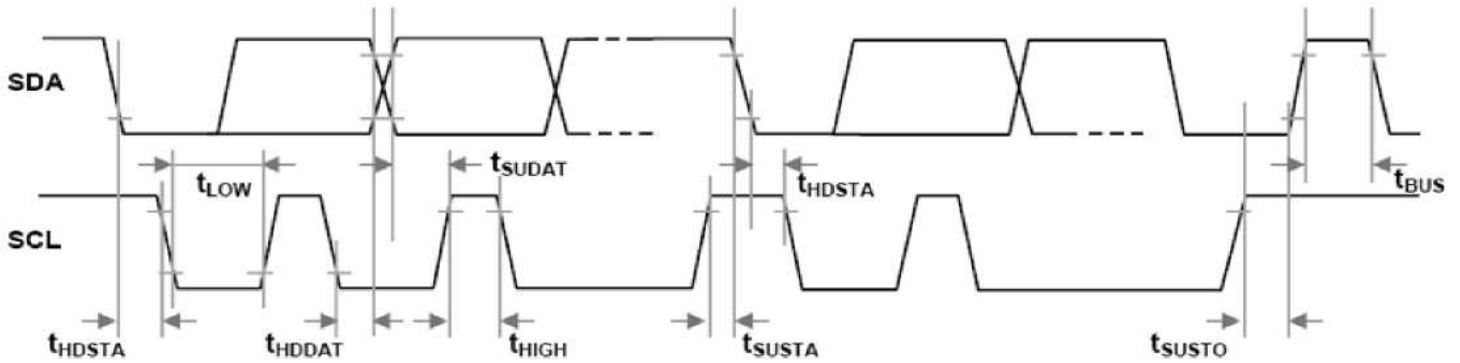

I²C Timing

Parameter	Symbol	MIN	TYP	MAX	Units
SCL Clock Frequency	F_{SCL}	100		400	kHz
Start Condition Hold Time Relative to SCL Edge	t_{HDSTA}	0.1			μ s
Minimum SCL Clock Low Width ¹	t_{LOW}	0.6			μ s
Minimum SCL Clock High Width ¹	t_{HIGH}	0.6			μ s
Start Condition Hold Time Relative to SCL Edge	t_{SUSTA}	0.1			μ s
Data Hold Time on SDA Relative to SCL Edge	t_{HDDAT}	0.0			μ s
Data Setup Time on SDA Relative to SCL Edge	t_{SUDAT}	0.1			μ s
Stop Condition Setup Time on SCL	t_{SUSTO}	0.1			μ s
Bus Free Time Between Stop Condition and Start Condition	t_{BUS}	2.0			μ s

5. Differences SM9541 I²C Protocol vs. Original I²C protocol

- **Note: There are three differences in the SM9541 protocol compared with the original I²C protocol**
- Sending a start-stop condition without any transitions on the CLK line (no clock pulses in between) created a communication error for the next communication, even if the next start condition is correct and the clock pulse is applied. An additional start condition must be sent, which results in restoration of proper communication.
- The restart condition - a falling SDA edge during data transmission when the CLK clock line is still high - creates the same situation. The next communication fails, and an additional start condition must be sent for correct communication.
- A failing SDA edge is not allowed between the start condition and the first rising SCL edge. If using an I²C address with the first bit 0, SDA must be held low from the start condition through the first bit.

6. Diagnostic Features – Status Bits

- The SM9541 offers diagnostic features to ensure robust system operation. The diagnostic states are indicated by a transmission of the status of the 2 MSBs of the pressure high byte data.

Status Bits (2 MSBs of Output Packet)	Symbol
00	Normal operation, good data packet
01	Device in Command Mode
10 ⁽¹⁾	Stale data: Data that has already been fetched since the last measurement cycle
11	Diagnostic condition exists

Note⁽¹⁾: If a data fetch is performed before or during the first measurement after power-on reset, then “stale” will be returned, but this data is actually invalid because the first measurement has not been completed.

- When the two MSBs are 11, one of the following faults listed below is indicated:
 - Invalid EEPROM signature
 - Loss of bridge positive or negative
 - Bridge input short
 - Loss of bridge source
 - Loss of bridge sink (not valid for SM9541)
 - Loss of tail resistor (not valid for SM9541)
- All diagnostics are detected in the next measurement cycle and reported in the subsequent data fetch except for loss of tail resistor, which is detected in the next temperature measurement and reported in the subsequent data fetch. Once a diagnostic is reported, the diagnostic status bits will not change unless both the cause of the diagnostic is fixed and a power-on-reset is performed.

SOIC-16 Package Dimensions

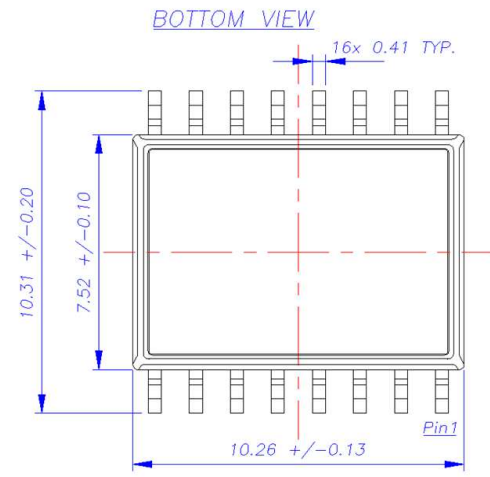
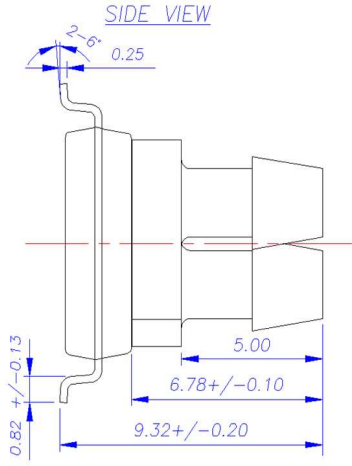
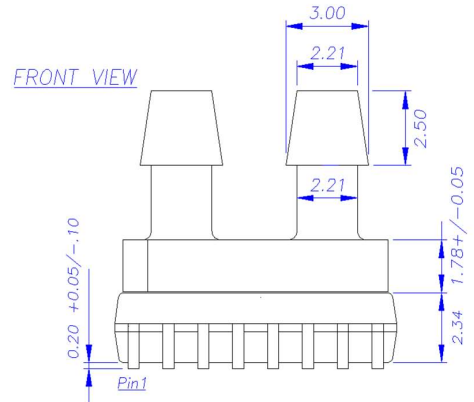
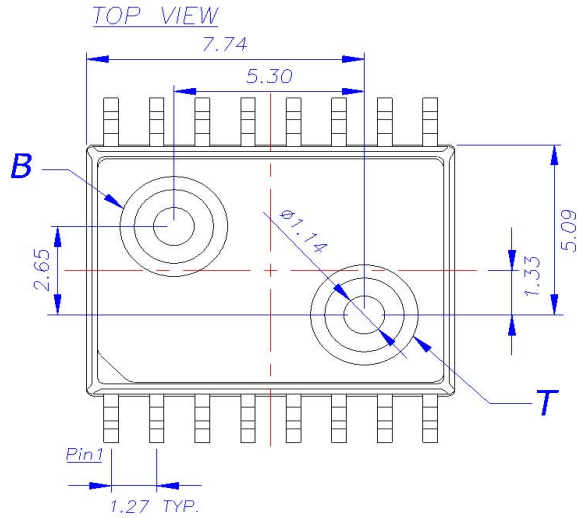

- All dimensions in units of [mm]
- Moisture Sensitivity Level (MSL): Level 3
- Wetted materials: Silicon, glass, copper, silicone, epoxy, mold compound.
- Tolerance on all dimensions ± 0.13 mm unless otherwise specified.
- [B] is tube connected to bottom side of sensor die.
- [T] is tube connected to top side of sensor die. For correct sensor output, higher pressure needs to be connected to this port.

Part & Lot Number Identification

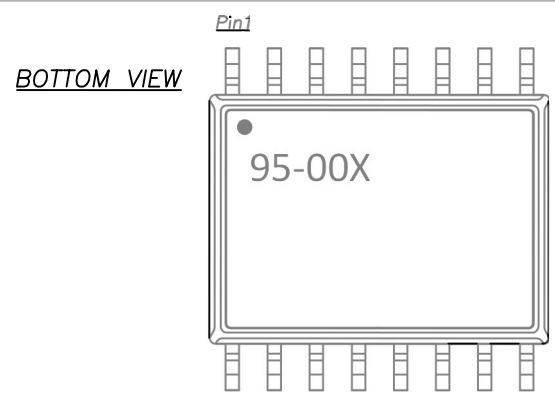
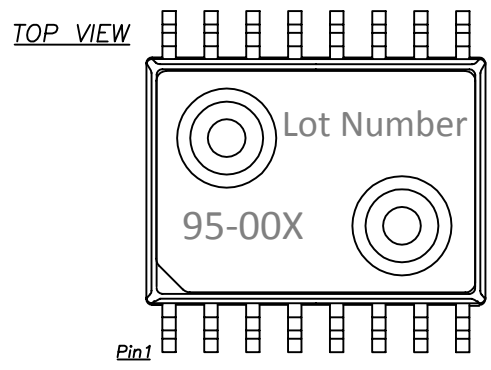

Package Labeling

Pin Number	Pin Function
1	NC
2	NC
3	Bridge Output High (analog)
4	NC
5	NC
6	GND
7	VDD
8	NC
9	NC
10	SDA
11	SCL
12	NC
13	Bridge Output Low (analog)
14	NC
15	NC
16	NC

NOTES:

- Do not connect to NC pins.
- External connections to NC pins will cause part malfunction.
- Tolerance on all dimensions ± 0.13 mm unless otherwise specified.
- [B] is tube connected to bottom side of sensor die.
- [T] is tube connected to top side of sensor die. For correct sensor output, higher pressure needs to be connected to this port.

Ordering Information

Order Code	Part Marking	Negative Pressure Range	Positive Pressure Range	Pressure Type	Tube Configuration	Shipping Method
SM9541-010C-S-C-213-S	95 - 001	-0.5 cmH ₂ O	10 cmH ₂ O	Compound Gauge	Dual Vertical	45 Units (per stick)
SM9541-010C-D-C-213-S	95 - 001	-10 cmH ₂ O	10 cmH ₂ O	Differential		
SM9541-020C-S-C-213-S	95 - 002	-1 cmH ₂ O	20 cmH ₂ O	Compound Gauge		
SM9541-020C-D-C-213-S	95 - 002	-20 cmH ₂ O	20 cmH ₂ O	Differential		
SM9541-040C-S-C-213-S	95 - 002	-5 cmH ₂ O	40 cmH ₂ O	Compound Gauge		
SM9541-040C-D-C-213-S	95 - 002	-40 cmH ₂ O	40 cmH ₂ O	Differential		
SM9541-100C-S-C-213-S	95 - 003	-5 cmH ₂ O	100 cmH ₂ O	Compound Gauge		
SM9541-100C-D-C-213-S	95 - 003	-100 cmH ₂ O	100 cmH ₂ O	Differential		

Pressure Conversion Chart

Unit	10 cmH ₂ O	20 cmH ₂ O	40 cmH ₂ O	100 cmH ₂ O
PSI	0.14	0.3	0.6	1.4
kPa	1.0	2.0	3.9	9.8
mbar	10	20	39	98
bar	0.01	0.02	0.04	0.10
in*H ₂ O	4	8	16	39
mm*Hg	7.4	14.7	29.4	73.6
hPa	10	20	39	98
in*Hg	0.29	0.58	1.16	2.90
Pa	981	1,961	3,923	9,807

Silicon Microstructures Warranty and Disclaimer:

Silicon Microstructures, Inc. reserves the right to make changes without further notice to any products herein and to amend the contents of this data sheet at any time and at its sole discretion.

Information in this document is provided solely to enable software and system implementers to use Silicon Microstructures, Inc. products and/or services. No express or implied copyright licenses are granted hereunder to design or fabricate any silicon-based microstructures based on the information in this document.

Silicon Microstructures, Inc. makes no warranty, representation, or guarantee regarding the suitability of its products for any particular purpose, nor does Silicon Microstructures, Inc. assume any liability arising out of the application or use of any product or silicon-based microstructure, and specifically disclaims any and all liability, including without limitation consequential or incidental damages. "Typical" parameters which may be provided in Silicon Microstructure's data sheets and/or specifications can and do vary in different applications and actual performance may vary over time. All operating parameters, including "Typicals", must be validated for each customer application by customer's technical experts. Silicon Microstructures, Inc. does not convey any license under its patent rights nor the rights of others. Silicon Microstructures, Inc. makes no representation that the circuits are free of patent infringement. Silicon Microstructures, Inc. products are not designed, intended, or authorized for use as components in systems intended for surgical implant into the body, or other applications intended to support or sustain life, or for any other application in which the failure of the Silicon Microstructures, Inc. product could create a situation where personal injury or death may occur. Should Buyer purchase or use Silicon Microstructures, Inc. products for any such unintended or unauthorized application, Buyer shall indemnify and hold Silicon Microstructures, Inc. and its officers, employees, subsidiaries, affiliates, and distributors harmless against all claims, costs, damages, and expenses, and reasonable attorney fees arising out of, directly or indirectly, any claim of personal injury or death associated with such unintended or unauthorized use, even if such claim alleges that Silicon Microstructures, Inc. was negligent regarding the design or manufacture of the part.

Silicon Microstructures, Inc. warrants goods of its manufacture as being free of defective materials and faulty workmanship. Silicon Microstructures, Inc. standard product warranty applies unless agreed to otherwise by Silicon Microstructures, Inc. in writing; please refer to your order acknowledgement or contact Silicon Microstructures, Inc. directly for specific warranty details. If warranted goods are returned to Silicon Microstructures, Inc. during the period of coverage, Silicon Microstructures, Inc. will repair or replace, at its option, without charge those items it finds defective. The foregoing is buyer's sole remedy and is in lieu of all warranties, expressed or implied, including those of merchantability and fitness for a particular purpose. In no event shall Silicon Microstructures, Inc. be liable for consequential, special, or indirect damages.

While Silicon Microstructures, Inc. provides application assistance personally, through its literature and the Silicon Microstructures, Inc. website, it is up to the customer to determine the suitability of the product for its specific application. The information supplied by Silicon Microstructures, Inc. is believed to be accurate and reliable as of this printing. However, Silicon Microstructures, Inc. assumes no responsibility for its use. Silicon Microstructures, Inc. assumes no responsibility for any inaccuracies and/or errors in this publication and reserves the right to make changes without further notice to any products or specifications herein

Silicon Microstructures, Inc.TM and the Silicon Microstructures, Inc. logo are trademarks of Silicon Microstructures, Inc. All other service or product names are the property of their respective owners.

© Silicon Microstructures, Inc. 2001-2014. All rights reserved.