

## KEY FEATURES

- U Bracket Switching Power Supply
- Universal Input: 90-264 VAC
- Active P.F.C. Function, PF>0.9
- 300W Conduction Cooling
- 300W Convection with 18CFM FAN
- Current Share Function
- Over Current / Over Voltage /  
Over Temperature / Short Circuit Protection
- 3-Year Product Warranty

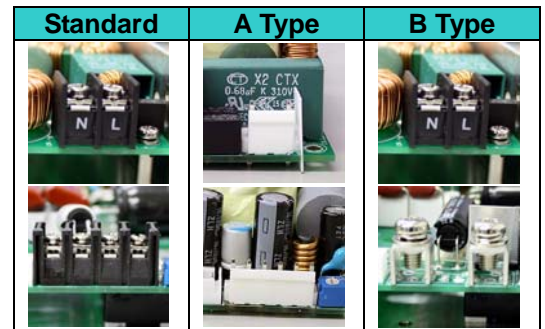

## ELECTRICAL SPECIFICATIONS



All specifications valid at normal input voltage, full load and +25°C after warm-up time unless otherwise stated.

Model No.	ABR300U-12S	ABR300U-24S	ABR300U-28S	ABR300U-48S
Max Output Wattage (18CFM FAN) (W)	300W	300W	308W	300W
Max Output Wattage (Conduction Cooling) (W)	300W			
Input	Voltage			
	90-264 VAC			
	Frequency (Hz)			
	50/60 Hz (47-63 Hz)			
	Current (Full load)			
<4.0 A (100 VAC) / <2.0 A max. (200 VAC)				
Inrush Current (<2ms)				
< 70 A max. (115 VAC) / < 90 A max. (230 VAC)				
Power Factor (typ.)				
PF>0.95 (100 VAC) / PF>0.9 (230 VAC) at Full Load				
Output	Voltage (V.DC.)			
	12V	24V	28V	48V
	Voltage Accuracy			
	±2%			
	Trim (V.DC)			
	11.04~ 12.96V	22.08 ~ 25.92V	25.76 ~ 30.24V	44.16 ~ 51.84V
	Current (A) (max.)			
	25	12.5	11	6.25
	Line Regulation (LL-HL) (typ.)			
	±1%			
	Load Regulation (10-100%) (typ.)			
	±2%	±1%		
	Minimum Load			
0%				
Maximum Capacitive Load				
5000 uF	2500 uF	2500 uF	1250 uF	
Ripple & Noise (max.)				
150mVp-p	200mVp-p	200mVp-p	300mVp-p	
Efficiency (%) (at 230 VAC)				
88.5%	89%	89%	90%	
Remote Sensing				
Provided				
Hold-up Time (at 230 VAC)				
10 ms min.				
Protection	Over Power Protection			
	Auto recovery			
	Over Voltage Protection			
	Auto recovery			
Over Temperature				
Auto recovery				
Short Circuit Protection				
Protection level 1 (nominal) : Continuous, Auto recovery				
Protection level 2 (instantaneous high current) : Latch				
Isolation	Input-Output (V.AC)			
	3000V			
	Input-FG (V.AC)			
1500V				
Output-FG (V.AC)				
500V				
Environment	Operating Temperature			
	-40°C...+65°C (with derating)			
	Storage Temperature			
	-40°C...+85°C			
	Temperature Coefficient			
	±0.05%/°C ( 0~50°C )			
Humidity				
20~95% RH (Non condensing)				
MTBF				
>200,000 h @ 25°C (MIL-HDBK-217F)				
Vibration				
10~500Hz, 2G 10min./1cycle, 60min. each along X, Y, Z axes.				
Physical	Dimension (L x W x H)			
	6.0 x 4.18 x 1.38 Inches (150.0 x 106.0 x 35.0 mm ) Tolerance ±0.5 mm			
	Weight			
560 g				
Cooling Method				
Conduction cooling				
Safety	Agency Approvals			
CE (In Progress)				
EMC	EMI (Conducted & Radiated Emission)			
	EN 55022 Conducted Class B & Radiated Class A (In Progress)			
EMS (Noise Immunity)				
EN 55024 · EN61000-4-2,3,4,5,6,8,11				

**NOTE**

1. Ripple & Noise are measured at 20MHz of bandwidth with ceramic 0.1uF & chemi-con KY 47uF parallel capacitor.

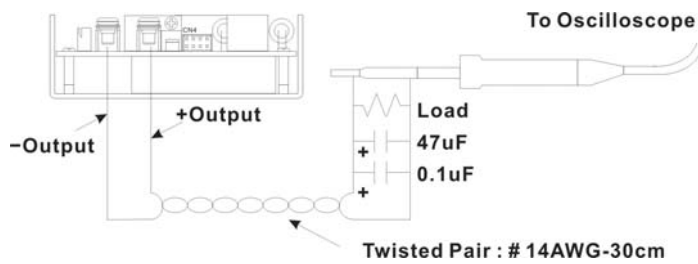

A 30cm twisted pair of no.14 AWG copper wire is connected to a 47uF and 0.1uF capacitor of proper polarity and voltage rating. The oscilloscope probe ground lead should connect right to the ground ring of the probe and be as short as possible. The oscilloscope bandwidth should be at 20MHz and connected to AC ground.

2. Hold-up Time measured at 90% Vout.
3. Strongly recommend to conduct this test with DC Voltage. If customer wishes to test with AC Voltage, please disconnect all Y-Capacitors within Arch power supply.
4. The ABR300UC Series should be conduction-cooled. Use a heatsink or fan to dissipate heat.
5. Current Share:
- The output voltage difference of each parallel single element should be less than 0.2 Vout.
  - Output power at parallel operation = rated power per unit x number of unit x 90%
  - Connect in parallel no more than 2 units. Please contact ARCH for advice if more than 2 is needed.
  - Minimum Load Should be 30% @ Vout 12V; Minimum Load Should be 15% @ Vout 24V, 28V and 48V.

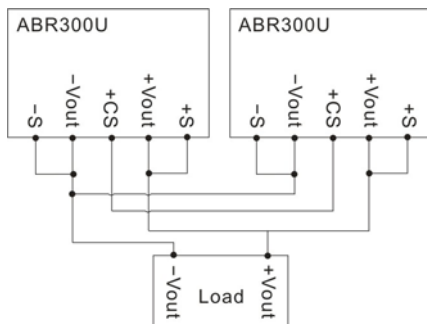

6. For heat dissipation, at least 5cm installation distance around the PSU should be kept, shown below:  
450 x 350 x 2.5mm

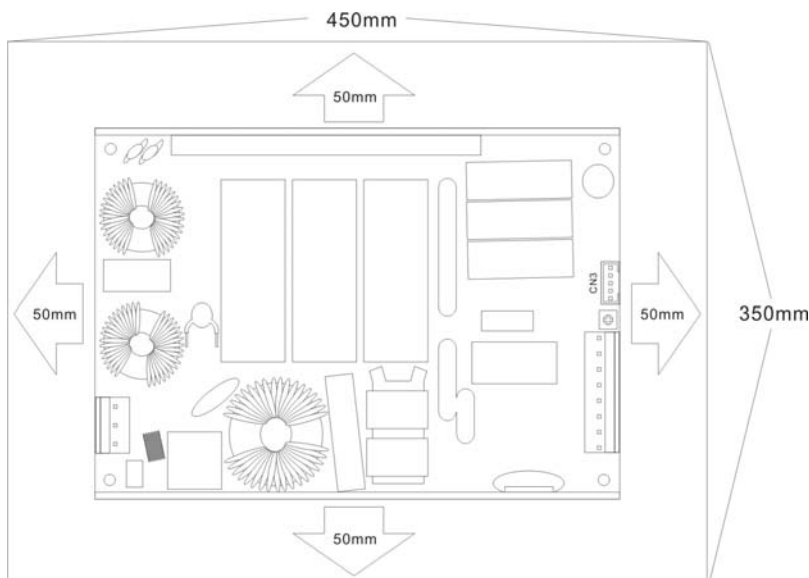

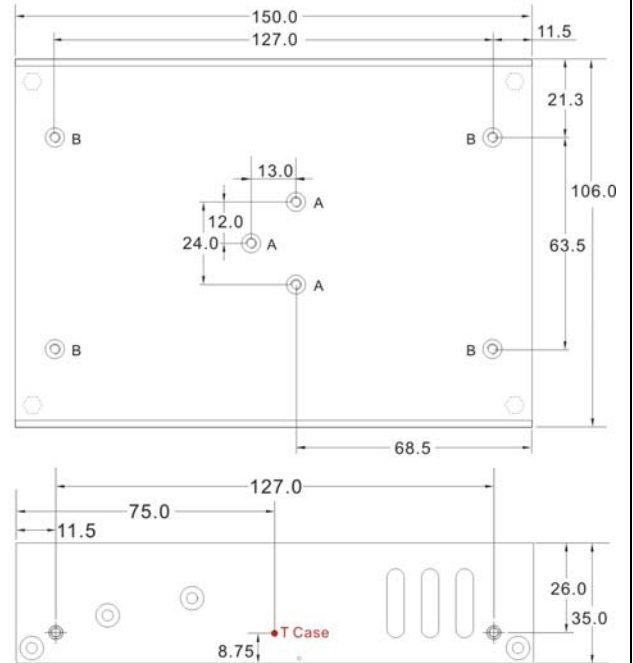
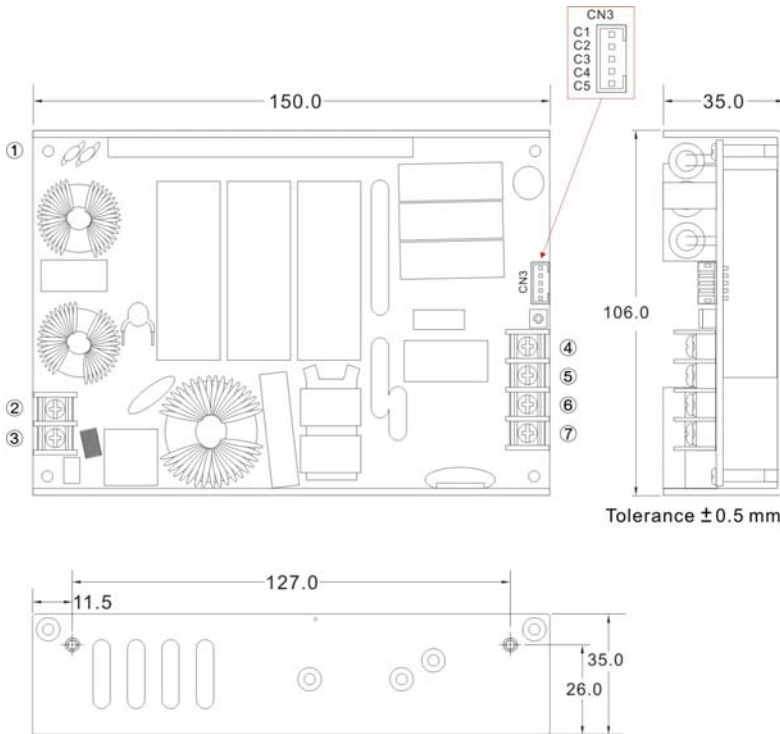
**MECHANICAL DIMENSION ( Top View )**
**Standard**

**ASSEMBLY INSTRUCTIONS**

\*U Case T=2.0mm

Customer is advised to screw into the threads no more than 2.0mm

PIN#	Single
1 & A	PE
2	AC IN (N)
3	AC IN (L)
4-5	+DC OUT
6-7	-DC OUT

A=For fixture to din rail clip only

B=For fixture to pcb/chassis only

A=M3x0.5P

B=M3x0.5P

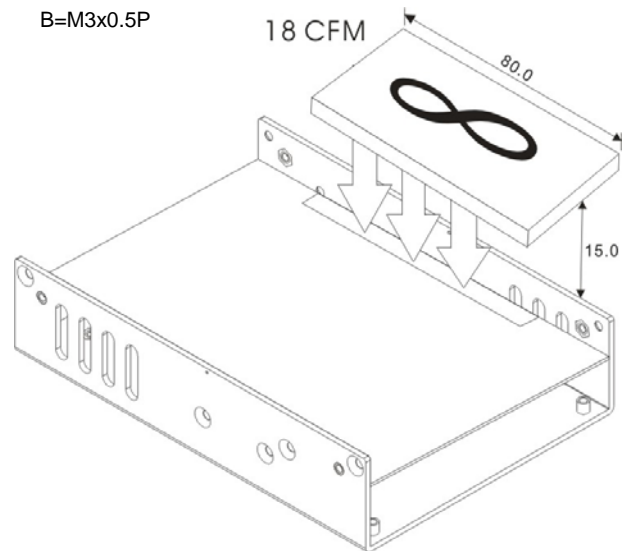

Connector Pin (CN3) = Cherg Weei CP-W20-05			
PIN#	Single	Mating Housing	Terminal
C1	-V	Cherg Weei CP-H20-05 or equivalent	Cherg Weei CP-T20B or equivalent
C2	CS		
C3	+S		
C4	-S		
C5	ENA		

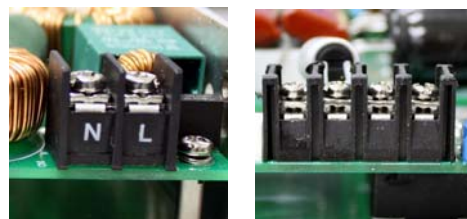

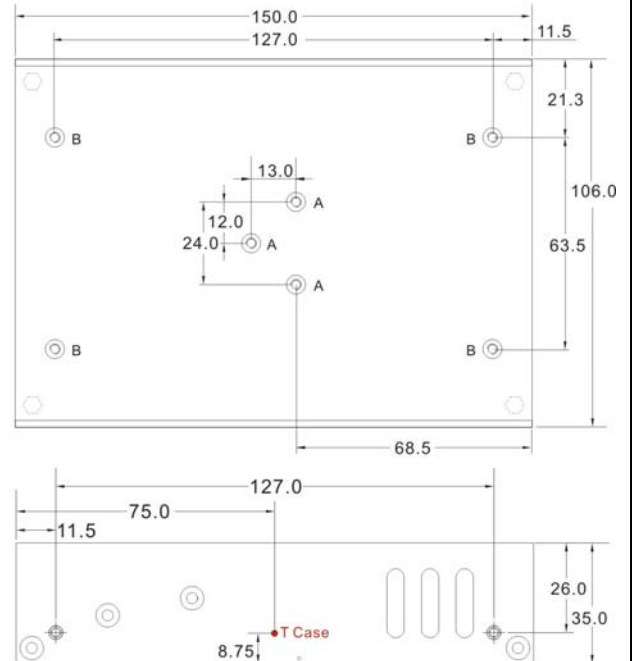
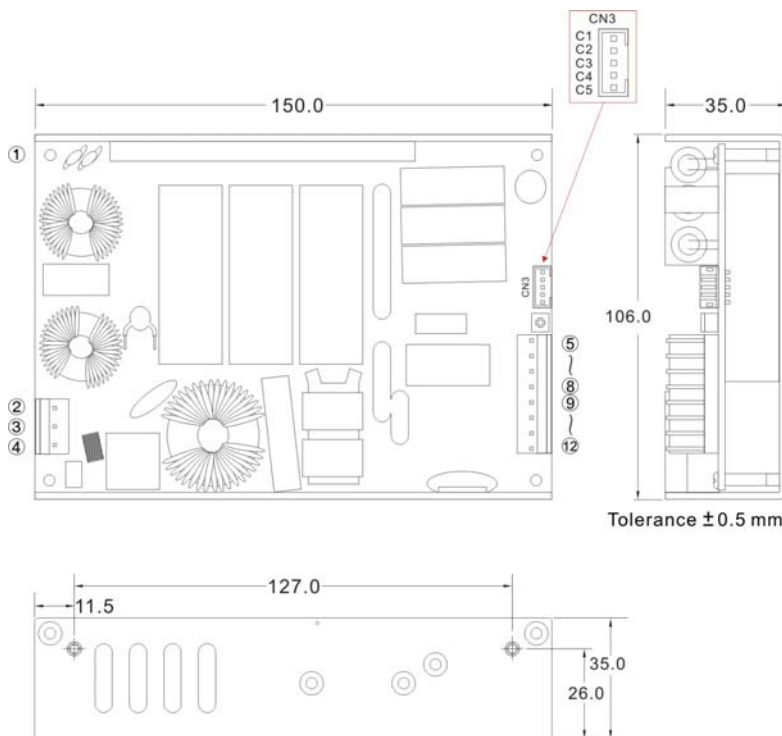
**MECHANICAL DIMENSION ( Top View )**
**A Type**

**ASSEMBLY INSTRUCTIONS**

\*U Case T=2.0mm

Customer is advised to screw into the threads no more than 2.0mm

A=For fixture to din rail clip only

B=For fixture to pcb/chassis only

A=M3x0.5P

B=M3x0.5P

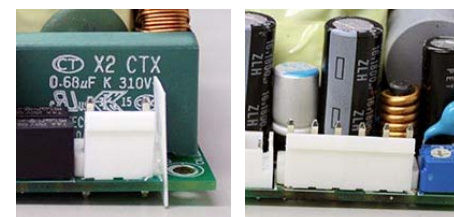
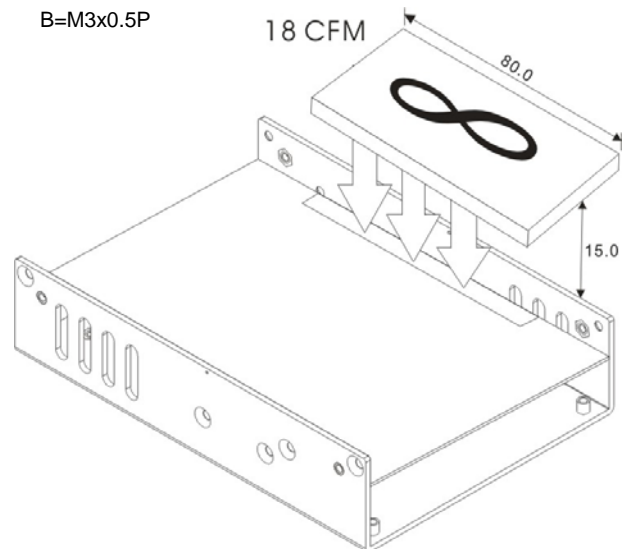

PIN#	Single	Mating Housing	Terminal
1 & A	PE		
<b>AC Input Connector Pin : Alex 9397-3</b>			
2	AC IN (N)	Alex 9396-3 or equivalent	Alex 96T Series or equivalent
3	NO PIN		
4	AC IN (L)		
<b>DC Output Connector Pin : Alex 9397-8</b>			
5~8	+DC OUT	Alex 9396-8 or equivalent	Alex 96T Series or equivalent
9~12	-DC OUT		

<b>Connector Pin (CN3) = Cherg Weei CP-W20-05</b>			
PIN#	Single	Mating Housing	Terminal
C1	-V	Cherg Weei CP-H20-05 or equivalent	Cherg Weei CP-T20B or equivalent
C2	CS		
C3	+S		
C4	-S		
C5	ENA		

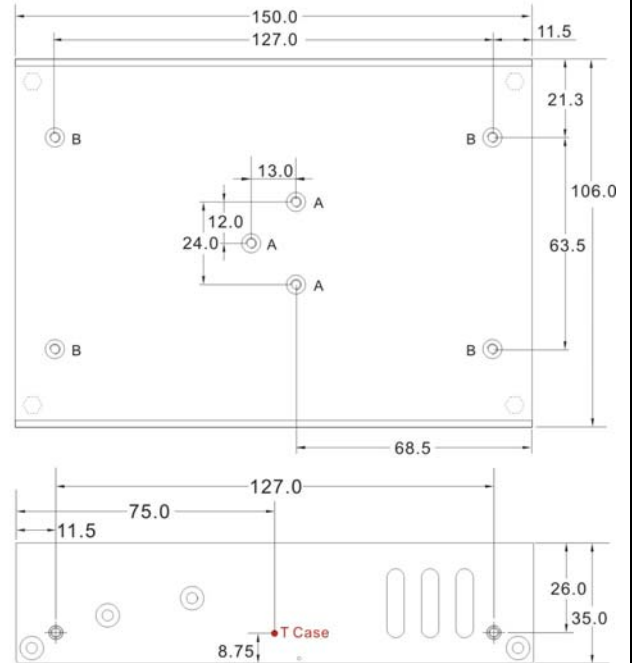
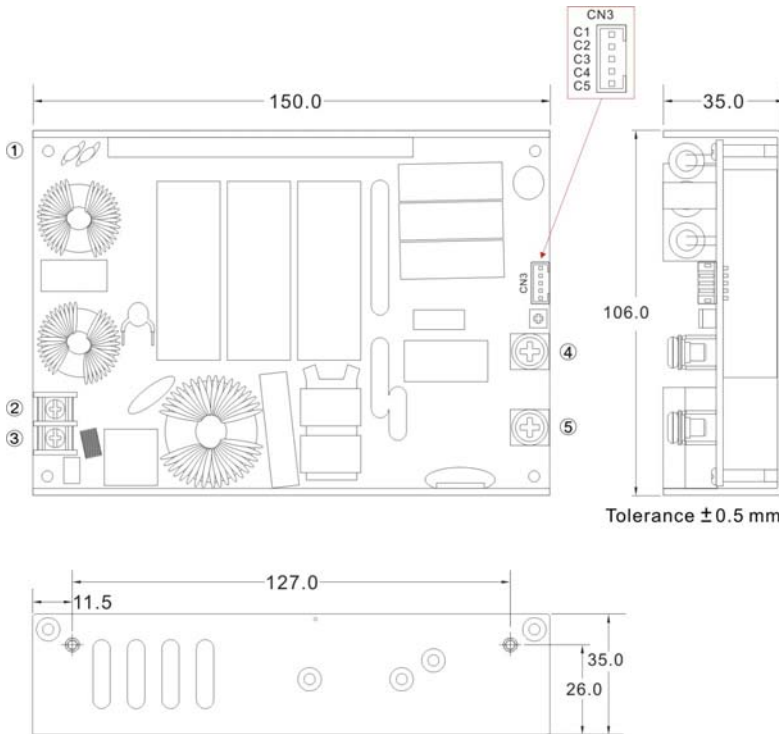
**MECHANICAL DIMENSION ( Top View )**
**B Type**

**ASSEMBLY INSTRUCTIONS**

\*U Case T=2.0mm

Customer is advised to screw into the threads no more than 2.0mm

PIN#	Single	Terminal
1 & A	PE	
<b>AC Input Connector Pin</b>		
2	AC IN (N)	
3	AC IN (L)	
<b>DC Output Connector Pin</b>		
4	+DC OUT	M5 Pan HD screw in 2 positions
5	-DC OUT	Torque to 8 lbs-in(90 cNm) max.

A=For fixture to din rail clip only

B=For fixture to pcb/chassis only

A=M3x0.5P

B=M3x0.5P

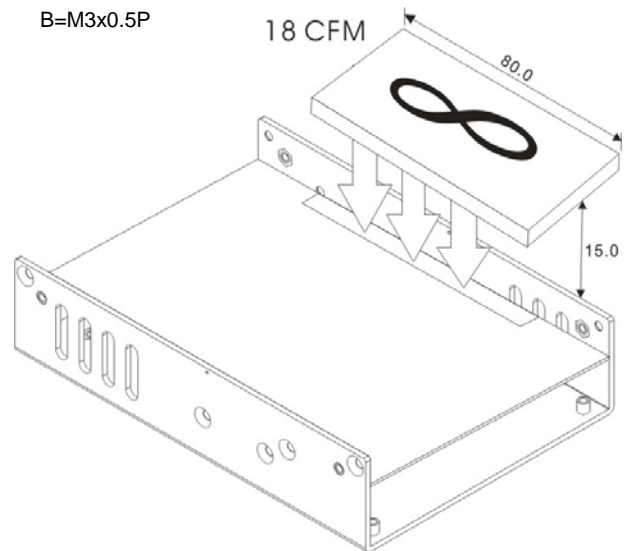

<b>Connector Pin (CN3) = Cherg Weei CP-W20-05</b>			
PIN#	Single	Mating Housing	Terminal
C1	-V	Cherg Weei CP-H20-05 or equivalent	Cherg Weei CP-T20B or equivalent
C2	CS		
C3	+S		
C4	-S		
C5	ENA		

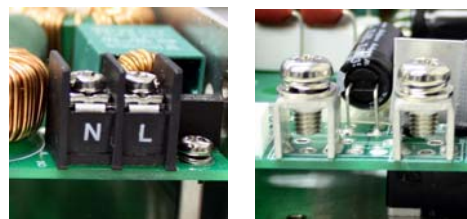

**FUNCTION DESCRIPTION of CN3 :**

Pin No.	Function	Description
C1	-V	-Vout
C2	CS	Current Share Function Pin
C3	+S	
C4	-S	
C5	ENA	Open collector (10mA sink current). Low when output is present.

**DERATING**

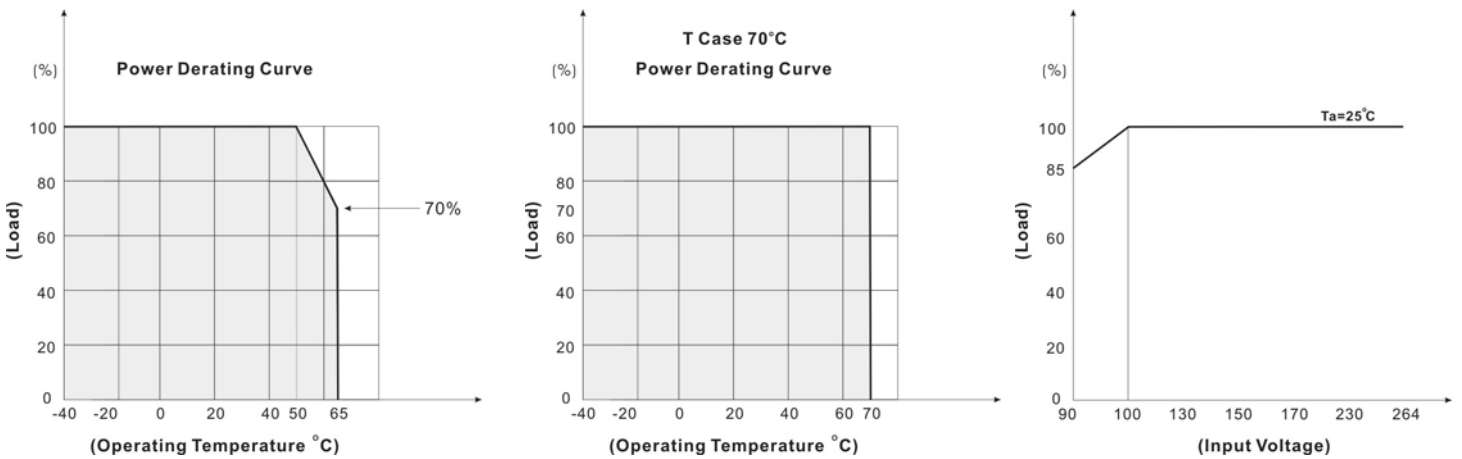

**BLOCK DIAGRAM**

