



UF624Z

Preliminary

Power MOSFET

**4.4A, 250V N-CHANNEL
POWER MOSFET**

■ DESCRIPTION

The UTC **UF624Z** is an N-Channel enhancement MOSFET, it uses UTC's advanced technology to provide customers with a minimum on-state resistance, high switching speed and low gate charge.

The UTC **UF624Z** is suitable for all commercial-industrial applications.

■ FEATURES

- * $R_{DS(ON)} < 1.1\Omega @ V_{GS}=10V, I_D=2.6A$
- * Low gate charge (Max=14nC)
- * Low C_{RSS} (Typ=15pF)
- * High switching speed
- * ESD resistant

■ SYMBOL

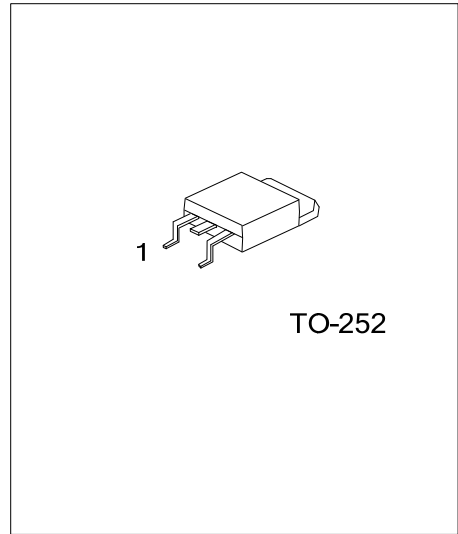
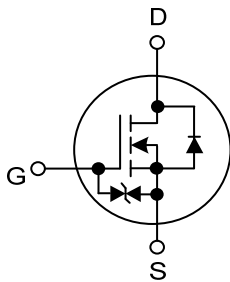

■ ORDERING INFORMATION

Ordering Number		Package	Pin Assignment			Packing
Lead Free	Halogen Free		1	2	3	
UF624ZL-TN3-T	UF624ZG-TN3-T	TO-252	G	D	S	Tube
UF624ZL-TN3-R	UF624ZG-TN3-R	TO-252	G	D	S	Tape Reel

Note: Pin Assignment: G: Gate D: Drain S: Source

<p>UF624ZL-TN3-T</p>	<p>(1) T: Tube, R: Tape Reel (2) TN3: TO-252 (3) L: Lead Free, G: Halogen Free</p>
----------------------	--

■ MARKING INFORMATION

PACKAGE	MARKING
TO-252	<p>UTC UF624Z</p> <p>Lot Code ← [] [] [] [] [] → Data Code</p> <p>1</p> <p>L: Lead Free G: Halogen Free</p>

■ ABSOLUTE MAXIMUM RATINGS ($T_C=25^\circ\text{C}$, unless otherwise noted)

PARAMETER		SYMBOL	RATINGS	UNIT	
Drain-Source Voltage		V_{DSS}	250	V	
Gate-Source Voltage		V_{GSS}	± 20	V	
Drain Current	Continuous	I_D	V_{GS} at 10V, $T_C=25^\circ\text{C}$	4.4	A
			V_{GS} at 10V, $T_C=100^\circ\text{C}$	2.8	A
	Pulsed (Note 2)		I_{DM}	14	A
Avalanche Current (Note 2)		I_{AR}	4.4	A	
Avalanche Energy	Single Pulsed (Note 3)	E_{AS}	100	mJ	
	Repetitive (Note 2)	E_{AR}	5.0	mJ	
Peak Diode Recovery dv/dt (Note 4)		dv/dt	4.8	V/ns	
Power Dissipation ($T_C=25^\circ\text{C}$)		P_D	50	W	
Linear Derating Factor			0.40	W/ $^\circ\text{C}$	
Junction Temperature		T_J	-55~+150	$^\circ\text{C}$	
Storage Temperature Range		T_{STG}	-55~+150	$^\circ\text{C}$	

Notes: 1. Absolute maximum ratings are those values beyond which the device could be permanently damaged.

Absolute maximum ratings are stress ratings only and functional device operation is not implied.

2. Repetitive rating; pulse width limited by maximum junction temperature.

3. $V_{DD}=50\text{V}$, starting $T_J=25^\circ\text{C}$, $L=10.33\text{mH}$, $R_g=25\Omega$, $I_{AS}=4.4\text{A}$.

4. $I_{SD}\leq 4.4\text{A}$, $dI/dt\leq 90\text{A}/\mu\text{s}$, $V_{DD}\leq V_{DS}$, $T_J\leq 150^\circ\text{C}$.

■ THERMAL CHARACTERISTICS

PARAMETER	SYMBOL	RATINGS	UNIT
Junction to Ambient	θ_{JA}	110	$^\circ\text{C}/\text{W}$
Junction to Case	θ_{JC}	2.5	$^\circ\text{C}/\text{W}$

■ ELECTRICAL CHARACTERISTICS ($T_J=25^\circ\text{C}$, unless otherwise noted)

PARAMETER	SYMBOL	TEST CONDITIONS	MIN	TYP	MAX	UNIT
OFF CHARACTERISTICS						
Drain-Source Breakdown Voltage	BV_{DSS}	$I_D=250\mu\text{A}$, $V_{GS}=0\text{V}$	250			V
Breakdown Voltage Temperature Coefficient	$\Delta BV_{DSS}/\Delta T_J$	Reference to 25°C , $I_D=1\text{mA}$		0.36		$\text{V}/^\circ\text{C}$
Drain-Source Leakage Current	I_{DSS}	$V_{DS}=250\text{V}$, $V_{GS}=0\text{V}$			25	μA
		$V_{DS}=200\text{V}$, $V_{GS}=0\text{V}$, $T_J=125^\circ\text{C}$			250	μA
Gate-Source Leakage Current	I_{GSS}	$V_{GS}=+20\text{V}$, $V_{DS}=0\text{V}$			± 10	μA
		$V_{GS}=-20\text{V}$, $V_{DS}=0\text{V}$			± 10	μA
ON CHARACTERISTICS						
Gate Threshold Voltage	$V_{GS(TH)}$	$V_{DS}=V_{GS}$, $I_D=250\mu\text{A}$	2.0		4.0	V
Static Drain-Source On-State Resistance	$R_{DS(ON)}$	$V_{GS}=10\text{V}$, $I_D=2.6\text{A}$ (Note 2)			1.1	Ω
Forward Transconductance	g_{FS}	$V_{DS}=50\text{V}$, $I_D=2.6\text{A}$ (Note 2)	1.5			S
DYNAMIC PARAMETERS						
Input Capacitance	C_{ISS}	$V_{GS}=0\text{V}$, $V_{DS}=25\text{V}$, $f=1.0\text{MHz}$		260		pF
Output Capacitance	C_{OSS}			77		pF
Reverse Transfer Capacitance	C_{RSS}			15		pF
SWITCHING PARAMETERS						
Total Gate Charge	Q_G	$V_{GS}=10\text{V}$, $V_{DS}=50\text{V}$, $I_D=1.3\text{A}$ $I_G=100\mu\text{A}$			18	nC
Gate to Source Charge	Q_{GS}				6	nC
Gate to Drain Charge	Q_{GD}				4	nC
Turn-ON Delay Time	$t_{D(ON)}$	$V_{DD}=30\text{V}$, $I_D=0.5\text{A}$, $R_G=25\Omega$		28		ns
Rise Time	t_R			145		ns
Turn-OFF Delay Time	$t_{D(OFF)}$			90		ns
Fall-Time	t_F			170		ns
SOURCE- DRAIN DIODE RATINGS AND CHARACTERISTICS						
Maximum Body-Diode Continuous Current	I_S				4.4	A
Maximum Body-Diode Pulsed Current (Note 1)	I_{SM}				14	A
Drain-Source Diode Forward Voltage	V_{SD}	$T_J=25^\circ\text{C}$, $I_S=4.4\text{A}$, $V_{GS}=0\text{V}$ (Note 2)			1.8	V
Body Diode Reverse Recovery Time	t_{RR}	$T_J=25^\circ\text{C}$, $I_F=4.4\text{A}$, $di/dt=100\text{A}/\mu\text{s}$ (Note 2)		200	400	ns
Body Diode Reverse Recovery Charge	Q_{RR}			0.93	1.9	μC

Notes: 1. Repetitive rating; pulse width limited by maximum junction temperature.

2. Pulse width $\leq 300\mu\text{s}$; duty cycle $\leq 2\%$.

■ TEST CIRCUITS AND WAVEFORMS

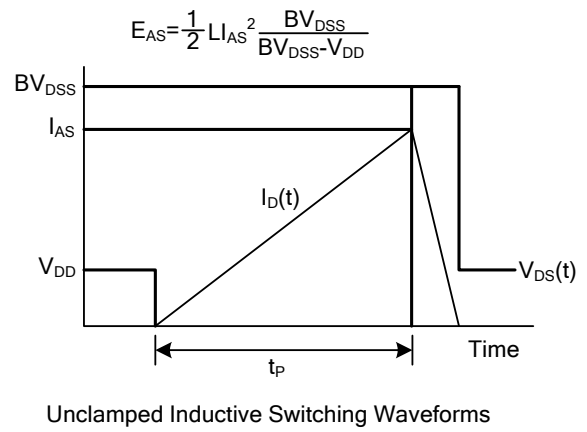
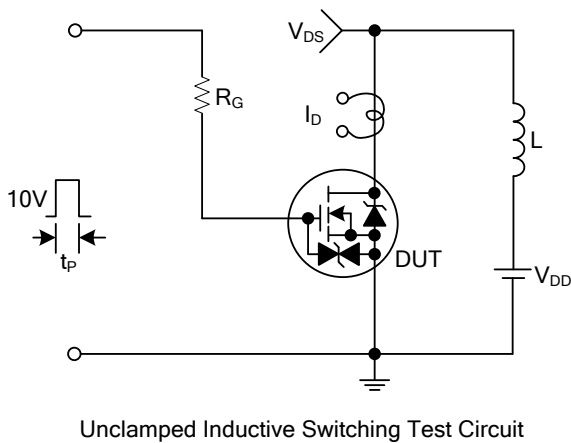
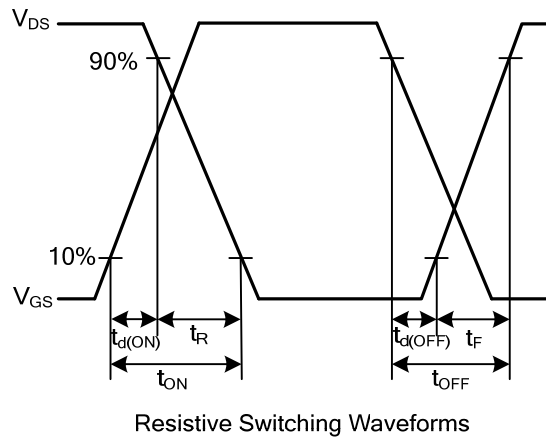
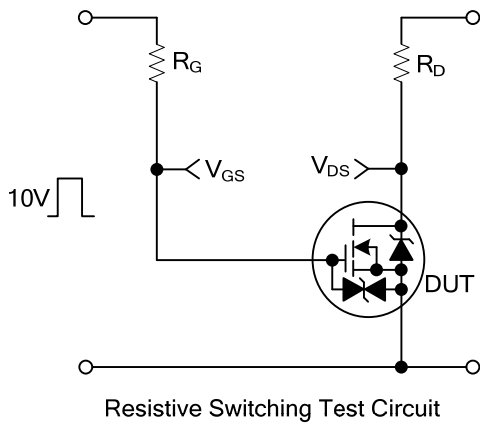
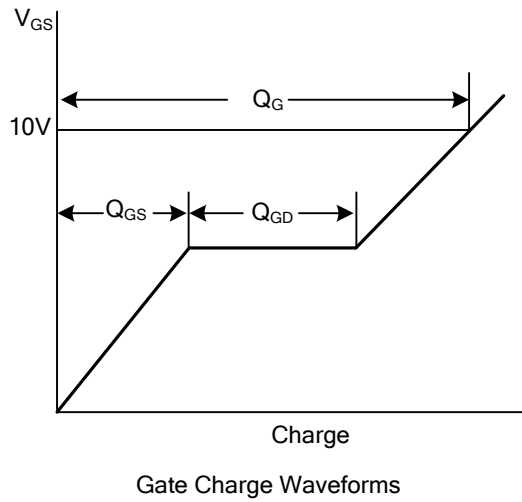
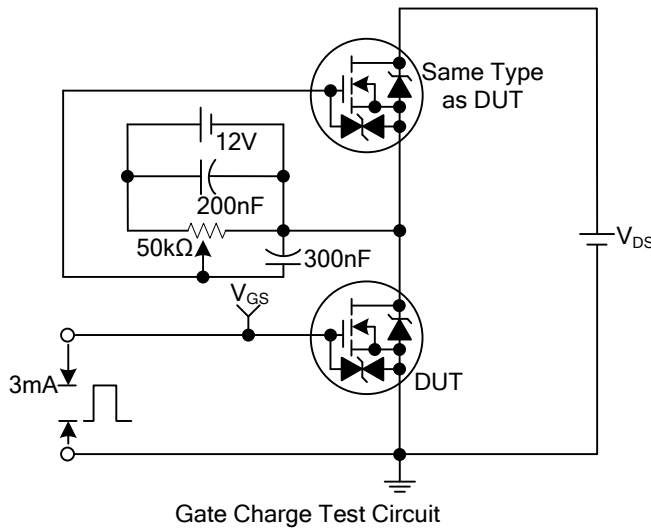

■ TEST CIRCUITS AND WAVEFORMS(Cont.)

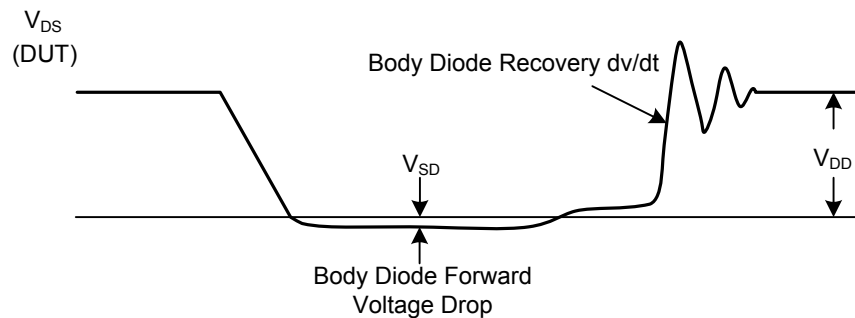
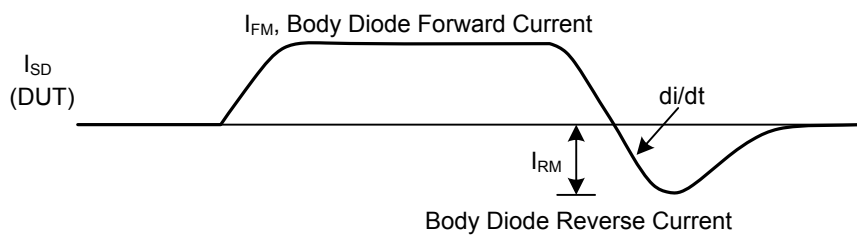
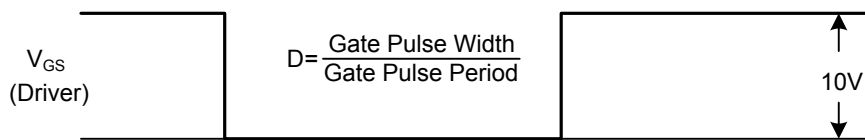
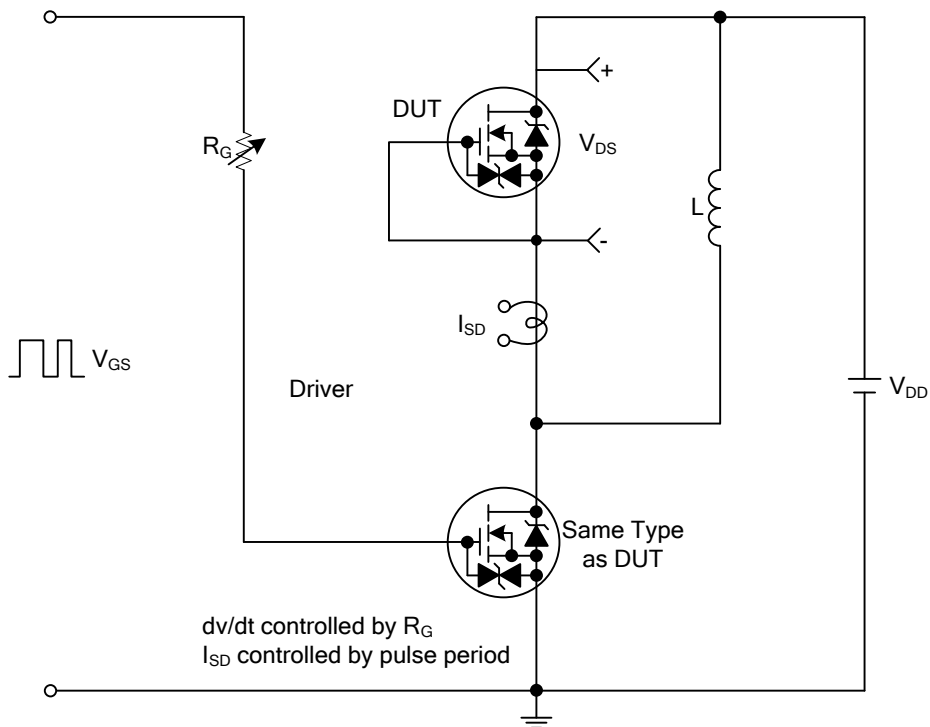

Peak Diode Recovery dv/dt Test Circuit and Waveforms

UTC assumes no responsibility for equipment failures that result from using products at values that exceed, even momentarily, rated values (such as maximum ratings, operating condition ranges, or other parameters) listed in products specifications of any and all UTC products described or contained herein. UTC products are not designed for use in life support appliances, devices or systems where malfunction of these products can be reasonably expected to result in personal injury. Reproduction in whole or in part is prohibited without the prior written consent of the copyright owner. The information presented in this document does not form part of any quotation or contract, is believed to be accurate and reliable and may be changed without notice.