

Verpackt in Tray
Verpackungseinheit 24 Stck

tray packaging
packaging unit 24 pcs

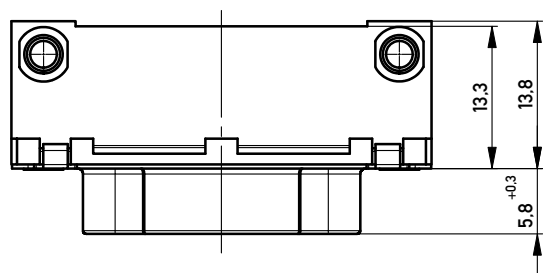
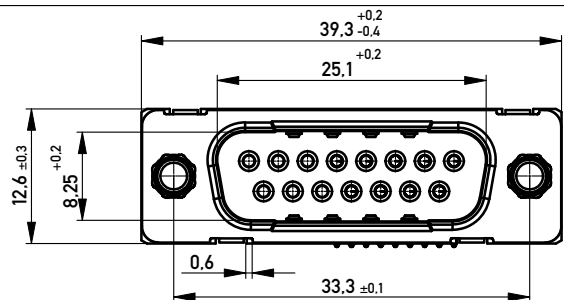

Mutter / nut

Bolzen / bolt

Anwendungsbeispiel / example of use

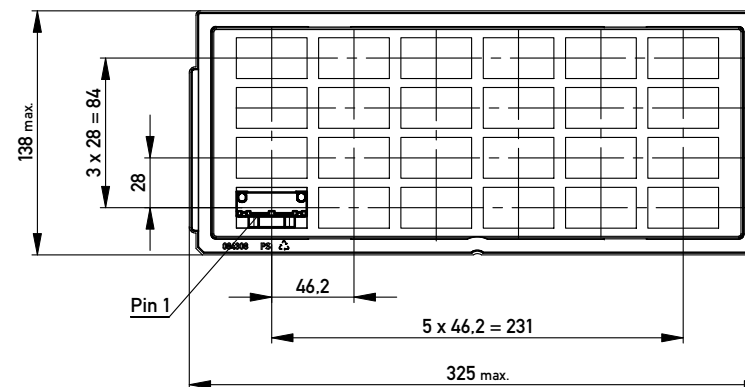

Sonstige Angaben siehe Zeichnung 204630 / Additional indications according to drawing 204630

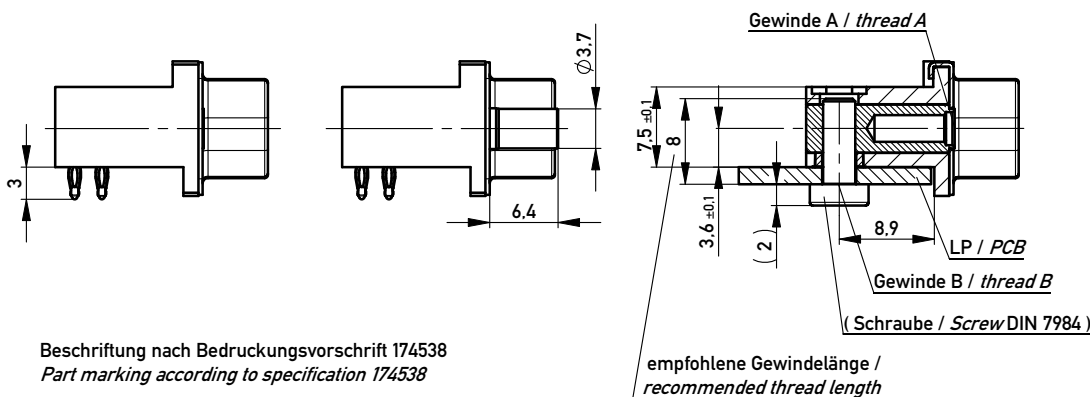

Beschriftung nach Bedruckungsvorschrift 174538
Part marking according to specification 174538

Anschlussbereich verzinkt
terminal area tin plating

Anforderungsstufe: 2
class: 2

			#4-40	M3	
			M3	#4-40	
284493			#4-40	#4-40	
			M3	M3	
	#4-40	M3			
	M3	#4-40			
284492	#4-40	#4-40			
284491	M3	M3			
	Gewinde A thread A	Gewinde B thread B	Gewinde A thread A	Gewinde B thread B	
Ident-Nr. part-no. Tray / tray	Quermutter nut		Querbolzen bolt		Bemerkung remark

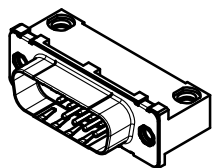

Layoutvorschlag
recommended layout

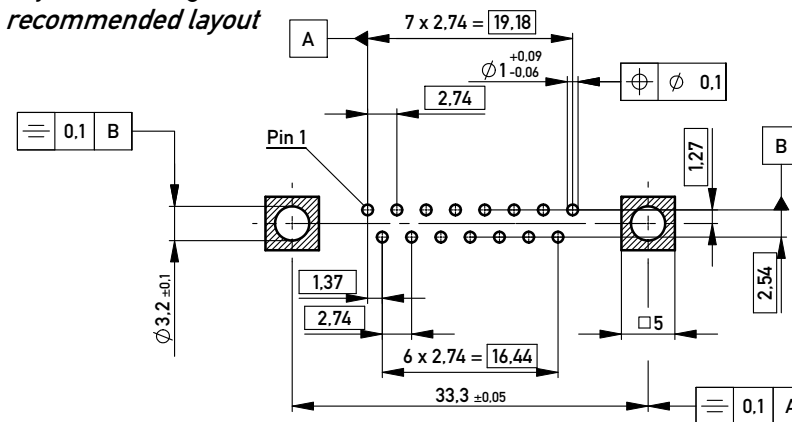

sonstige Angaben siehe 164062 / additional indications according to 164062

Fehlende Masse und Angaben siehe DIN 41652 / Missing information and dimensions according to DIN 41652
Sonstige Angaben siehe Fertigungsunterlagen / Additional indications according to production documentation

Information: All rights reserved. Only for Information. To ensure that this is the latest version of this drawing, please contact one of the ERNI companies before using.

Tolerances: All Dimensions in mm

Scale: 2:1

Designation: TMC-P-15-EE-SV-Euro-BA8-ZV
TMC-P-15-EE-SV-Euro-BA8-ZV

ERNI www.ERNI.com

224950

1 A3

Class TMCP

A 22.02.2010 Date

Copyright by ERNI GmbH. Proprietary notice pursuant to ISO 16106 to be observed.