

Order Number
200214-1112

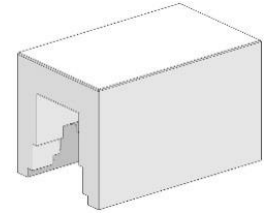

Application Tooling Specification

FEATURES

- Lightweight tool used in the insertion of QSFP-DD and BiPass cages in a PCB
- Inserts connector into a PCB without damaging the board

SCOPE

Products: Small Form-Factor Pluggable QSFP-DD and BiPass 1-by-1 Cages with Press-Fit PC Tails.

Connector Series No.	Connector Order No.					
111131	111131-1911	111131-1912	111131-1913	111131-1914	111131-1915	111131-1920
	111131-1921	111131-1922	111131-1923	111131-1924	111131-1930	111131-1931
	111131-1932	111131-1933	111131-1934	111131-1940	111131-1941	111131-1942
	111131-1943	111131-1944				
203143	203143-1231	203143-1232	203143-1233	203143-1234	203143-1235	203143-1236
	203143-1240	203143-1242	203143-1243	203143-1244	203143-1250	203143-1252
	203143-1253	203143-1254	203143-1255	203143-1256	203143-1340	203143-1341
	203143-1342	203143-1343	203143-1344	203143-1345	203143-1346	203143-1347
	203143-1348	203143-1349	203143-1350	203143-1351	203143-1352	203143-1353
	203143-1354	203143-1355	203143-1356	203143-1357	203143-1440	203143-1441
	203143-1442	203143-1443	203143-1444	203143-1445	203143-1446	203143-1447
	203143-1448	203143-1540	203143-1541	203143-1542	203143-1543	203143-1544
	203143-1545	203143-1546	203143-1547	203143-1548	203143-1640	203143-1641
	203143-1642	203143-1643	203143-1644	203143-1645	203143-1646	203143-1647
	203143-1648	203143-1927	203143-1937	203143-1940		
204427	204427-1001	204427-1002	204427-3001	204427-3002	204427-3901	
206358	206358-1001	206358-1002	206358-1003	206358-1004	206358-1005	206358-1006
	206358-1007	206358-1501	206358-1502	206358-1503	206358-1504	206358-1505
	206358-1506	206358-1507				
207364	207364-1100	207364-1200	207364-1300			
208426	208426-1001	208426-1002	208426-1003	208426-1004	208426-1005	208426-1006
	208426-1007	208426-1501	208426-1502	208426-1503	208426-1504	208426-1505
	208426-1506	208426-1507	208426-9100			
208473	208473-1001	208473-1002	208473-1003	208473-1004	208473-1005	208473-1006
	208473-1007	208473-1501	208473-1502	208473-1503	208473-1504	208473-1505
	208473-1506	208473-1507	208473-8000			
209351	209351-1001	209351-1002	209351-1003	209351-1004	209351-1005	209351-1006
	209351-1007	209351-1501	209351-1502	209351-1503	209351-1504	209351-1505
	209351-1506	209351-1507				

Notes

1. See the following page for tooling operation instructions.
2. This tool requires a "Keep Out Zone" to be free of components. The tool overhangs the rear of the cage to allow for light pipe options. The right and left sides should be at least 4.5mm (.18"). See Figure 1.

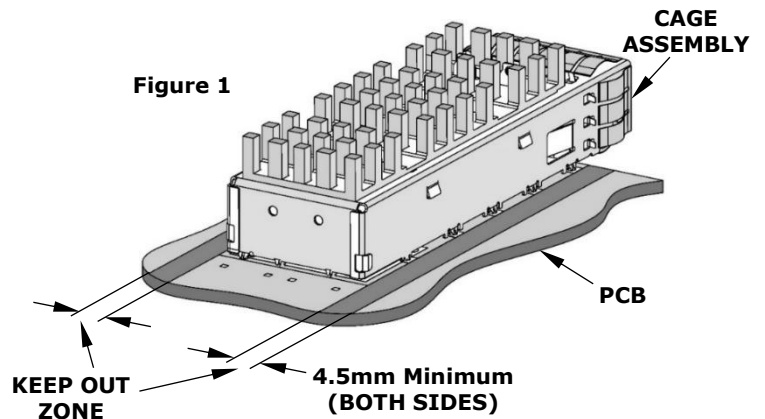

OPERATION

1. By hand, place a cage assembly on the PCB. Make sure all compliant tails are engaged in PCB holes.
2. Place the tool on the cage assembly, oriented as shown in Figure 2.
3. Place the tool, cage and PCB in a press of suitable size and force, and seat the cage as shown. The PCB support (not furnished by Molex) must have clearance for the connector pins if they pass through the PCB.

Note: This insertion tool does not contact the PCB when the connector is fully seated.

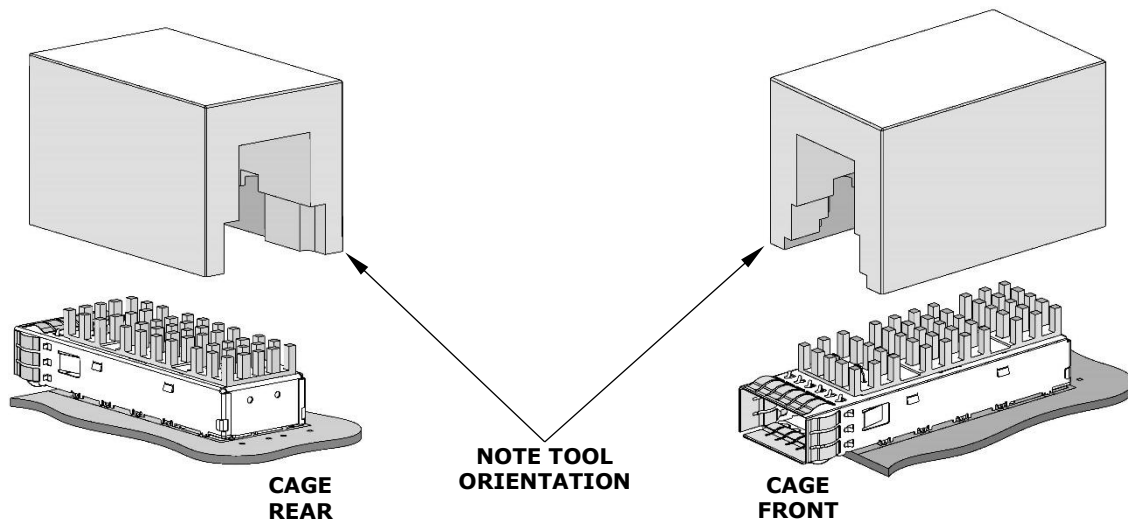
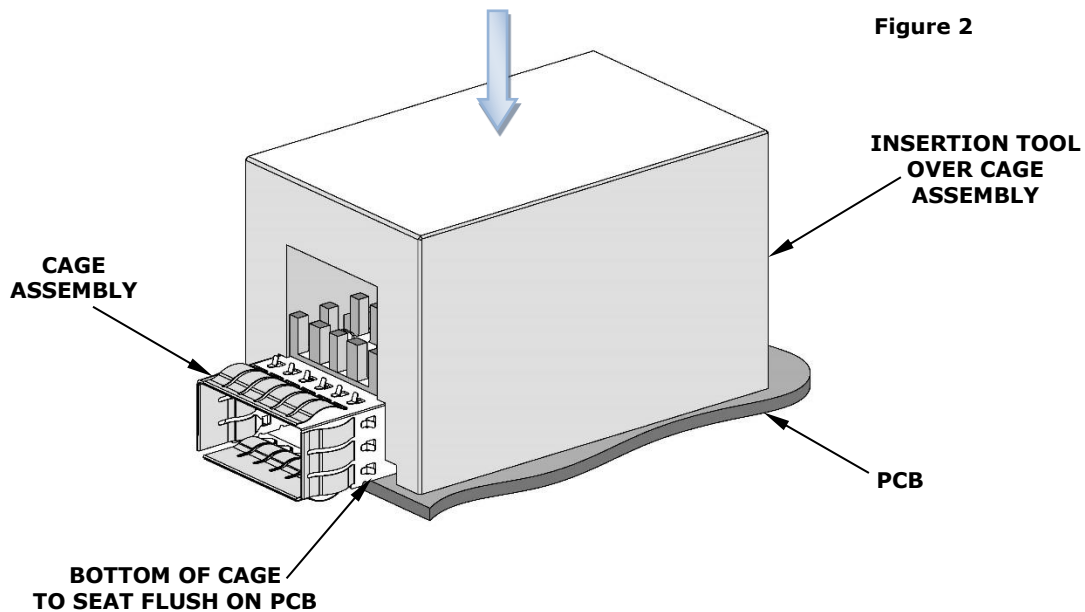

Figure 2



Application Tooling Support

Phone: (402) 458-TOOL (8665)
E-Mail: applicationtooling@molex.com
Website: www.molex.com/applicationtooling

Molex is a registered trademark of Molex, LLC in the United States of America and may be registered in other countries; all other trademarks listed herein belong to their respective owners.