

Low Noise FTTx Amplifier 50 - 1000 MHz

Rev. V3

Features

- Low Distortion
- Low Noise Figure
- Lead-Free 4 mm 20-Lead PQFN Package
- Halogen-Free “Green” Mold Compound
- 260°C Reflow Compatible

Description

M/A-COM’s MAAM-007796 is a GaAs PHEMT MMIC amplifier in a lead-free 4 mm 20-lead PQFN package. The Amplifier is designed to meet the high gain, high linearity and low noise requirements of FTTx receivers.

Functional Schematic

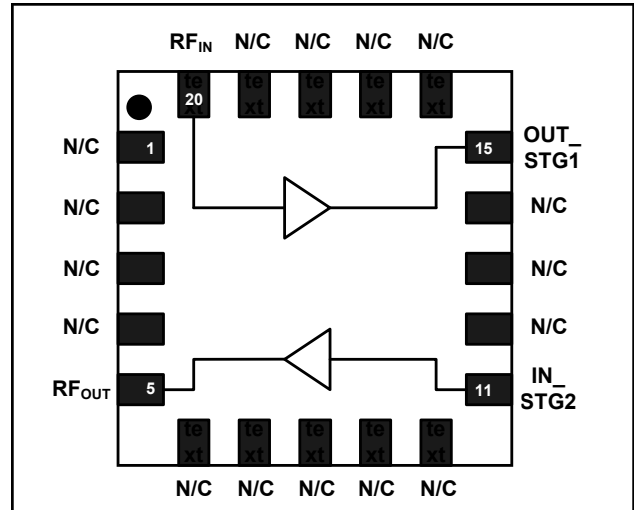

Ordering Information ^{1,2}

Part Number	Package
MAAM-007796-TR1000	1000 piece reel
MAAM-007796-TR3000	3000 piece reel
MAAM-007796-000SMB	Sample Test Board

1. Reference Application Note M513 for reel size information.
2. All sample boards include 5 loose parts.

Absolute Maximum Ratings ^{3,4}

Parameter	Absolute Maximum
Input Power	+5 dBm
Operating Voltage	+10 volts
Operating Temperature	-40°C to +85°C
Storage Temperature	-65°C to +150°C

3. Exceeding any one or combination of these limits may cause permanent damage to this device.
4. M/A-COM does not recommend sustained operation near these survivability limits.

Pin Configuration ⁵

Pin No.	Pin Name	Description
1	N/C	No Connection
2	N/C	No Connection
3	N/C	No Connection
4	N/C	No Connection
5	RF_OUT	RF Output
6	N/C	No Connection
7	N/C	No Connection
8	N/C	No Connection
9	N/C	No Connection
10	N/C	No Connection
11	IN_STG2	STAGE 2 RF Input
12	N/C	No Connection
13	N/C	No Connection
14	N/C	No Connection
15	OUT_STG1	STAGE 1 RF Output
16	N/C	No Connection
17	N/C	No Connection
18	N/C	No Connection
19	N/C	No Connection
20	RF_IN	RF Input

5. The exposed pad centered on the package bottom must be connected to RF and DC ground.

* Restrictions on Hazardous Substances, European Union Directive 2002/95/EC.

ADVANCED: Data Sheets contain information regarding a product M/A-COM Technology Solutions is considering for development. Performance is based on target specifications, simulated results, and/or prototype measurements. Commitment to develop is not guaranteed.
PRELIMINARY: Data Sheets contain information regarding a product M/A-COM Technology Solutions has under development. Performance is based on engineering tests. Specifications are typical. Mechanical outline has been fixed. Engineering samples and/or test data may be available. Commitment to produce in volume is not guaranteed.

• **North America** Tel: 800.366.2266 / Fax: 978.366.2266
 • **Europe** Tel: 44.1908.574.200 / Fax: 44.1908.574.300
 • **Asia/Pacific** Tel: 81.44.844.8296 / Fax: 81.44.844.8298
 Visit www.macomtech.com for additional data sheets and product information.

M/A-COM Technology Solutions Inc. and its affiliates reserve the right to make changes to the product(s) or information contained herein without notice.

Electrical Specifications: $T_A = 25^\circ\text{C}$, Freq: 50 - 1000 MHz, $V_{DD} = +5$ Volts, $Z_0 = 75 \Omega$

Parameter	Test Conditions	Units	Min.	Typ.	Max.
Gain	RF_{IN} to RF_{OUT}	dB	20	21	22
Gain Flatness	RF_{IN} to RF_{OUT}	dB	0	0.4	0.7
Noise Figure	RF_{IN} to RF_{OUT}	dB	3	3.8	5.3
Input Return Loss	RF_{IN}	dB	-	15	-
Output Return Loss	RF_{OUT}	dB	-	15	-
Output IP3	Two tones at 397 & 403 MHz, +5 dBm output per tone	dBm	-	35	-
Composite Triple Beat, CTB	132 Channels, +20 dBmV/Channel at the Output	dBc	-	-70	-
Composite Second Order, CSO	132 Channels, +20 dBmV/Channel at the Output	dBc	-	-70	-68
Cross modulation	132 Channels, +20 dBmV/Channel at the Output	dBc	-	-70	-
P1dB	400 MHz	dBm	-	20	-
I_{DD}	$V_{DD} = +5$ Volts	mA	140	160	180

Test Circuit Schematic

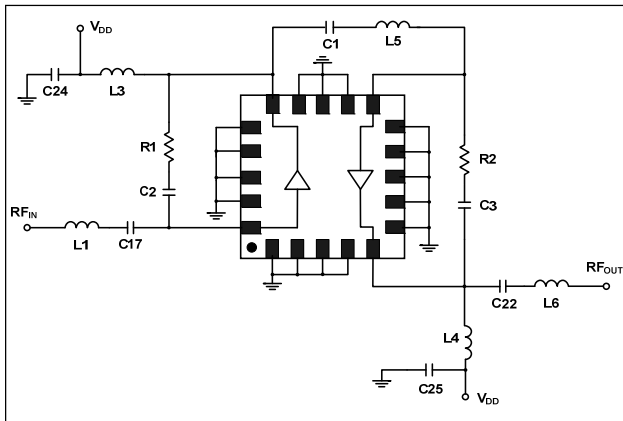

Off-Chip Component Values ⁶

Component	Value	Package
C1-C3, C17, C22, C24-C25	0.01 μF	0402
L1	5.6 nH	0402
L3, L4	1.0 μH	1210
L5	3.9 nH	0402
L6	4.7 nH	0402
R1, R2	300 Ω	0402

6. L3 and L4 supplied from EPCOS, part number B82422A1102K100.

Typical Performance Curves

Gain vs. Frequency over Temperature to 1 GHz

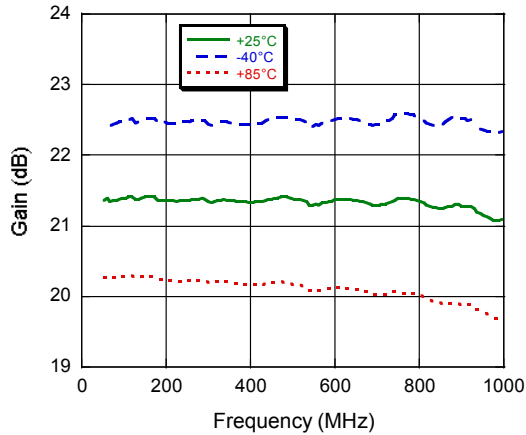

Gain vs. Frequency over Temperature to 3 GHz

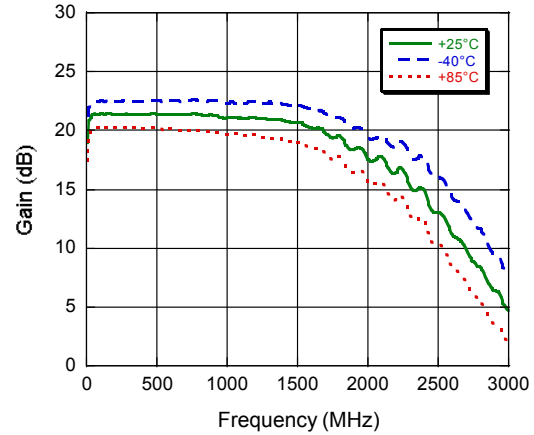

Input Return Loss vs. Frequency over Temperature

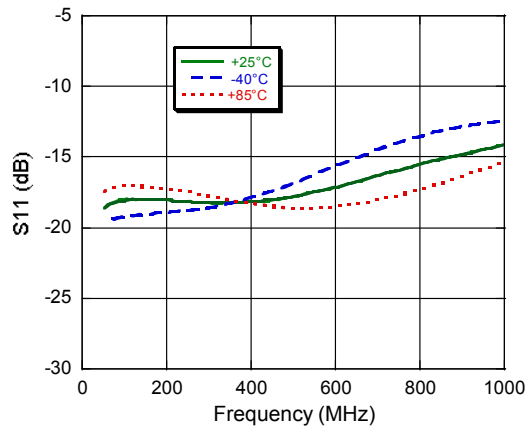

Output Return Loss vs. Frequency over Temperature

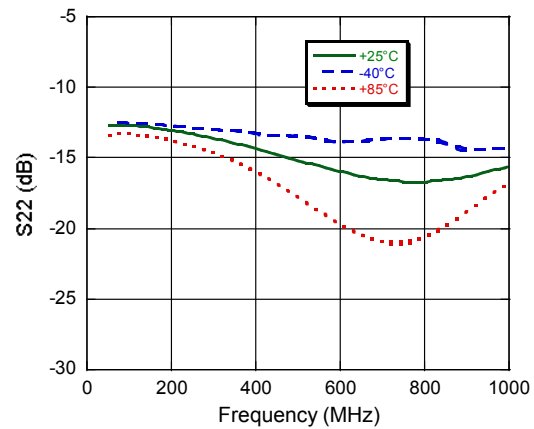

Noise Figure vs. Frequency

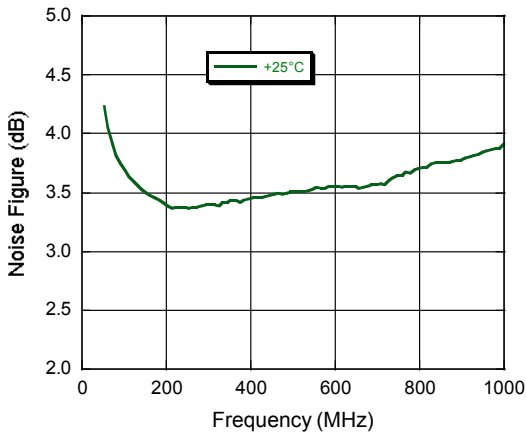

Lead-Free 4 mm 20-Lead PQFN†

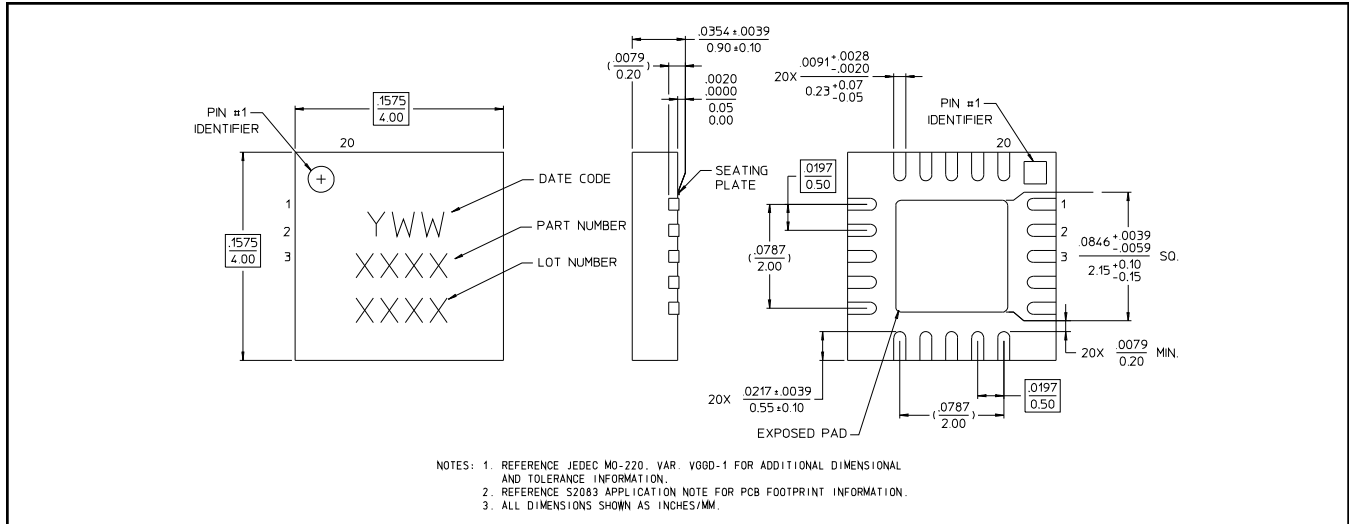

† Reference Application Note S2083 for lead-free solder reflow recommendations.
Meets JEDEC moisture sensitivity level 1 requirements.
Plating is 100% matte tin over copper.

Handling Procedures

Please observe the following precautions to avoid damage:

Static Sensitivity

Gallium Arsenide Integrated Circuits are sensitive to electrostatic discharge (ESD) and can be damaged by static electricity. Proper ESD control techniques should be used when handling these devices.