

NAS 1833 INSERT, MOLDED IN, THREADED, SELF-LOCKING, NONSELF LOCKING, SANDWICH PANEL

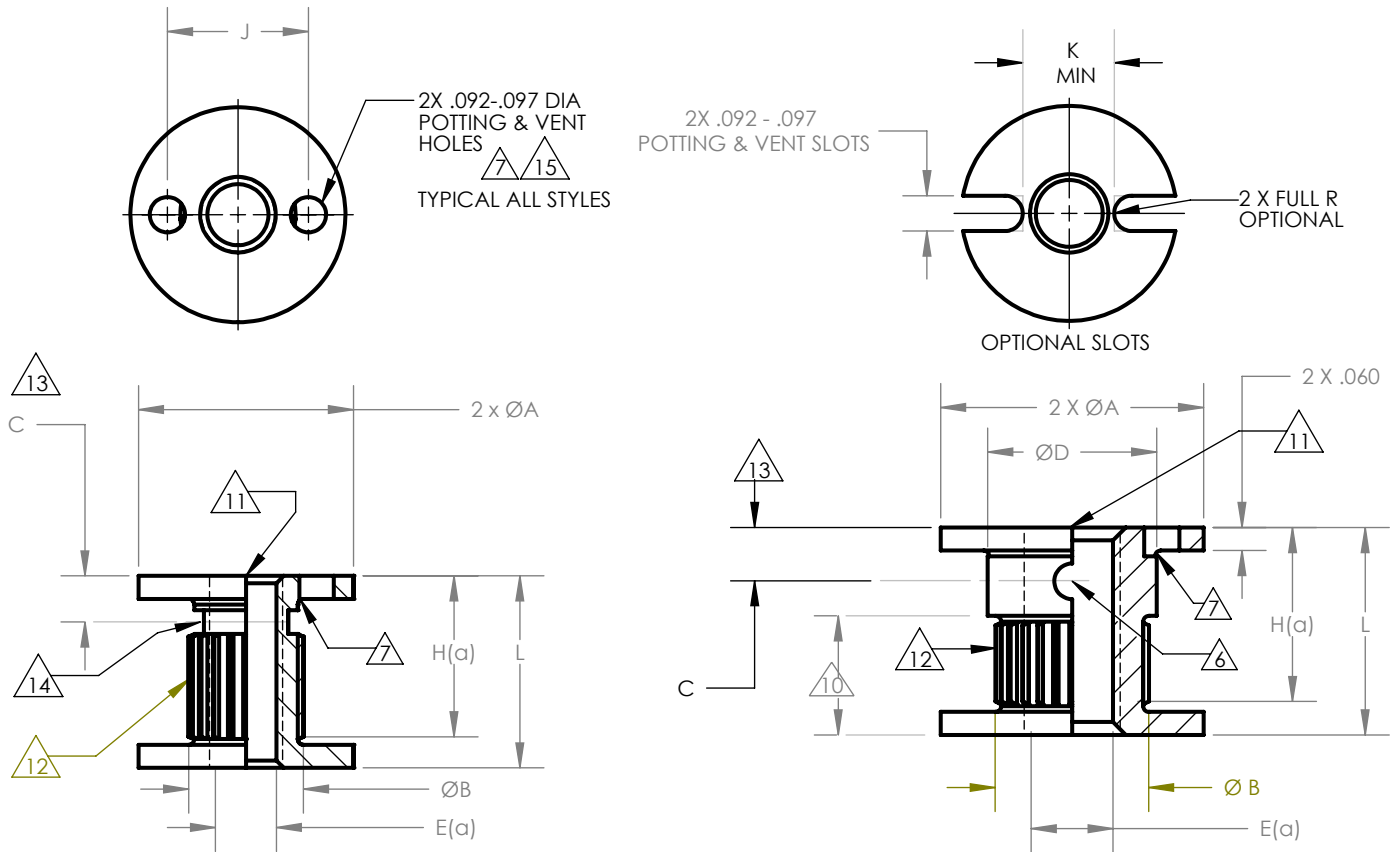

ALL STEEL AND CRES SELF-LOCKING AND NONSELF-LOCKING
OR NONSELF-LOCKING ALUMINUM STYLE INSERTS

ALUMINUM SELF-LOCKING STYLE OR ALTERNATE
NONSELF-LOCKING ALUMINUM STYLE

TABLE I

FIRST DASH NO	THREAD CLASS 3B MINOR DIA	ØA +.010 -.010	ØB	C	ØD	ØE (a)	H (a) MIN	J BASIC	K MIN	L(b) MIN	INSTALLATION HOLE SIZE
-06	.1380 - 32 UNJC	.560	.30	.12	.375	.139 - .145	.276	.367	.260	.250	.561 - .566
-08	.1640 - 32 UNJC	.560	.30	.12	.375	.168 - .174	.328	.367	.260	.250	.561 - .566
-3	.1900 - 32 UNJF	.560	.30	.12	.375	.195 - .201	.380	.367	.260	.250	.561 - .566
-4	.2500 - 28 UNJF	.685	.37	.14	.440	.256 - .263	.500	.467	.360	.312	.686 - .691
-5	.3125 - 24 UNJF	.685	.47	.16	.500	.315 - .322	.625	.467	.360	.312	.686 - .691
-6	.3750 - 24 UNJF	.841	.50	.22	.550	.376 - .383	.750	.591	.484	.375	.842 - .847

NAS 1833

INSERT, MOLDED IN, THREADED, SELF-LOCKING, NONSELF-LOCKING, SANDWICH PANEL

(a) MINIMUM THREAD "H" WHERE LENGTH PERMITS SHALL BE 2X DIAMETER OF THREAD. LENGTHS SHORTER THAN 2x DIAMETER OF THREAD SHALL BE THREADED THE ENTIRE LENGTH. LENGTHS LONGER THAN 2x DIAMETER MAY HAVE A THREAD RELIEF SHOWN BY Ø "E" AND "H". OR MAY BE THREADED THE ENTIRE LENGTH, (MFG OPTION).

(b) MINIMUM LENGTH MAY BE SPECIFIED.

MATERIAL: CARBON STEEL PER ASTM-A-108, ASTM A576 OR MATERIAL COMPOSITION PER FED-STD-66.
ULTIMATE TENSILE STRENGTH , 85 KSI MINIMUM
ALUMINUM ALLOY, GRADE 2024 (UNS A92024) TEMPER T4 OR T351 PER QQ-A-225/6.
CORROSION RESISTANT STEEL, TYPE 303 (UNS S30300) PER ASTM A582.
NONMETALLIC LOCKING ELEMENT - POLYAMIDE PER FED SPEC L-P-410

FINISH: CARBON STEEL - CADMIUM PLATE PER SAE-AMS-QQ-P-416, TYPE II, CLASS 2.
ALUMINUM ALLOY - ANODIZE PER MIL-A-8625 TYPE I, CLASS OPTIONAL.
CRES - PASSIVATE PER ASTM-A-967, TYPE II. SILVER PLATE PER AMS2410 OR
AMS2411 OR CADMIUM PLATE PER SAE-AMS- QQ-P-416 TYPE II, CLASS 2.
SOLID FILM LUBRICANT PER AS5272, TYPE I, APPLIED TO THREADS ONLY.

CODING: NO LETTER AFTER BASIC NUMBER INDICATES CARBON STEEL, CADMIUM PLATED.
SUFFIX A TO BASIC NUMBER INDICATES AL ALLOY ANODIZED.
SUFFIX C TO BASIC NUMBER INDICATES CRES, PASSIVATED.
FIRST DASH NUMBER INDICATES NOMINAL THREAD SIZE SEE TABLE I.
SUFFIX N TO FIRST DASH NUMBER INDICATES NON SELF-LOCKING.
SECOND DASH NUMBER INDICATES LENGTH IN THOUSANDTHS.
NO LETTER AFTER SECOND DASH NUMBER FOR CRES INDICATES PASSIVATE ONLY.
SEE NOTE 5.
SUFFIX M TO SECOND DASH NUMBER INDICATES SOLID FILM LUBRICANT.
SEE NOTE 5.
SUFFIX P TO SECOND DASH NUMBER INDICATES CADMIUM PLATE ON CRES INSERT.
SEE NOTE 5.
SUFFIX S TO SECOND DASH NUMBER INDICATES SILVER PLATE ON CRES INSERT.
SEE NOTE 5.

EXAMPLE OF PART NUMBER:

NAS 1833-3-500M .1900-32 UNJF -3B THREAD, CARBON STEEL, CADMIUM PLATED
WITH SOLID FILM LUBRICANT, .500 LONG, SELF-LOCKING.

NAS 1833A3N500 .1900-32 UNJF -3B THREAD, ALUMINUM ALLOY, ANODIZED, .500 LONG
NONSELF LOCKING.

NAS 1833CO8-375S .1640-32 UNJC -3B THREAD, CRES, SILVER PLATED, .375 LONG.
SELF-LOCKING.

NAS 1833C4N625 .250-28 UNJF -3B THREAD, CRES, PASSIVATED, .625 LONG
NONSELF-LOCKING

NAS 1833-4-1250 .2500-28 UNJF -3B THREAD, CARBON STEEL, CADMIUM PLATED, 1.250
LONG, SELF-LOCKING.

NAS 1833

INSERT, MOLDED IN, THREADED, SELF-LOCKING, NON SELF-LOCKING, SANDWICH PANEL

NOTES:

1. THREADED PER MIL-S-8879.
2. LOCKING TORQUE PER MIL-DTL-25027 EXCEPT SELF-LOCKING, CORROSION RESISTANT STEEL INSERT WITHOUT PLATING OR LUBRICANT WILL BE TESTED USING A SILVER PLATED BOLT OR SCREW.
3. TOLERANCES UNLESS OTHERWISE SPECIFIED:
XXX = ± 0.10
XX = ± 0.02
4. AN ADHESIVE-BACKED INSTALLATION TAB NAS 1837 (PLASTIC PER WITTEN 2007) SHALL BE FURNISHED WITH EACH INSERT.
5. PLATING OR SOLID FILM LUBRICANT IS RECOMMENDED ON SELF-LOCKING CRES INSERTS.
6. NONMETALLIC THREAD LOCK WHEN APPLICABLE. LOCATE A PELLET NO CLOSER THAN 10° FROM EDGE OF EITHER POTTING HOLE OR SLOT.
7. BURRS CAUSED BY MACHINING POTTING HOLES OR SLOTS PERMISSIBLE UNDER FLANGE.
8. DIMENSIONING AND TOLERANCE PER ANSI Y 14.5M-1982.
9. DIMENSIONS IN INCHES UNLESS OTHERWISE NOTED.
10. EXTERNAL CONFIGURATION OPTIONAL IN THIS AREA FOR SHORT LENGTHS THROUGH .375.
11. MINIMUM "GO" THREAD GAGE PENETRATION SHALL BE ONE HALF REVOLUTION BEFORE LUBRICATION. MINIMUM BOLT THREAD PENETRATION SHALL BE THREE QUARTER REVOLUTION AFTER LUBRICATION.
12. STRAIGHT OR DIAMOND ANTIROTATIONAL KNURL (MFG. OPTION)
13. CENTERLINE OF THREAD LOCK WHEN APPLICABLE.
14. SHANK DEFORMED IN THIS AREA TO PROVIDE THREAD LOCK WHEN APPLICABLE.
15. POTTING AND VENT HOLES OR SLOTS MANUFACTURERS OPTION.
16. ALL DIAMETERS SHALL BE WITHIN .010 CIRCULAR RUNOUT TO DATUM A.
17. DIMENSIONAL LIMITS APPLY AFTER PLATING, PRIOR TO SOLID FILM LUBE.