

APPROVAL SHEET

To :

Customer P/N :

UDE P/N : RB1-2S5BAK1A

Description : RJ45 1X1 Tab Down

Through Hole

10/100/1000 Base-T

Contact Area : Gold Flash

LED:L-Green/Yellow;R-Green/Yellow



Spec No.
RB1475-00

Update Date
2017/5/15

Revision
B

Approved	Checked	Prepared



湧德電子 股份有限公司
UDE Corp.

桃園市(33852) 蘆竹區內溪路 68 巷13號

No.13, Ln. 68, Neixi Rd., Luzhu Dist., Taoyuan City (33852), Taiwan

TEL: 886-3-3242000 FAX: 886-3-3246611

<http://www.ude-corp.com/>

1. MECHANICAL DIMENSION

1.1 Product Dimension

Unit:mm	General Tolerance :	X.X : ± 0.38
		X.XX : ± 0.20

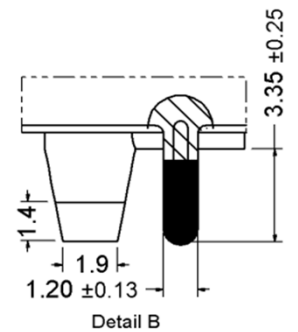
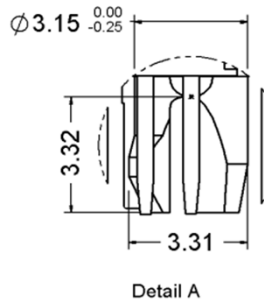
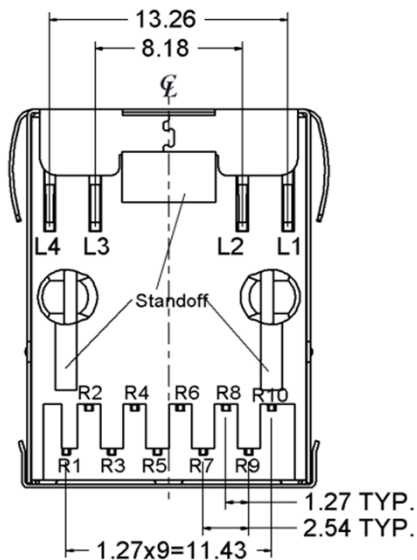
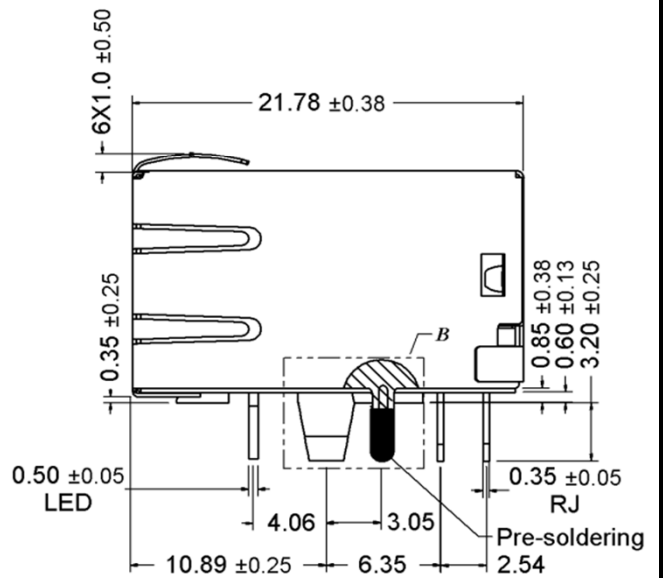
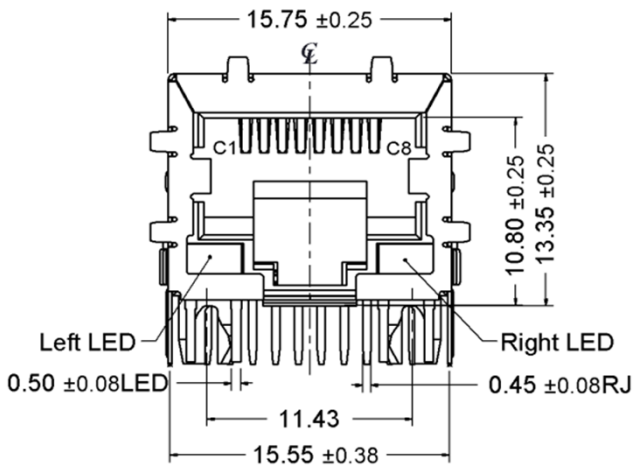
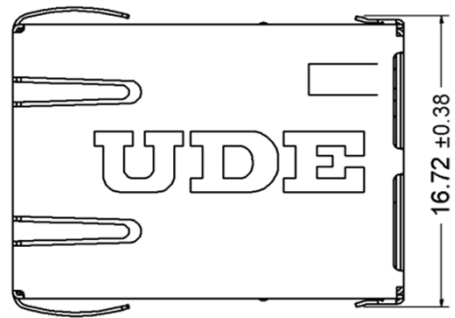
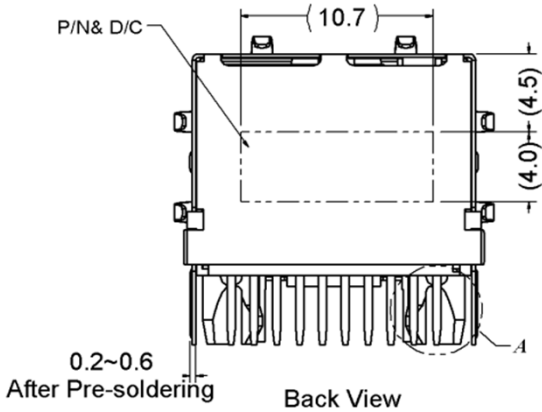

1.2 Recommended PCB Layout

Component Side of Board

All dimension tolerance are $\pm 0.05\text{mm}$ unless otherwise specified

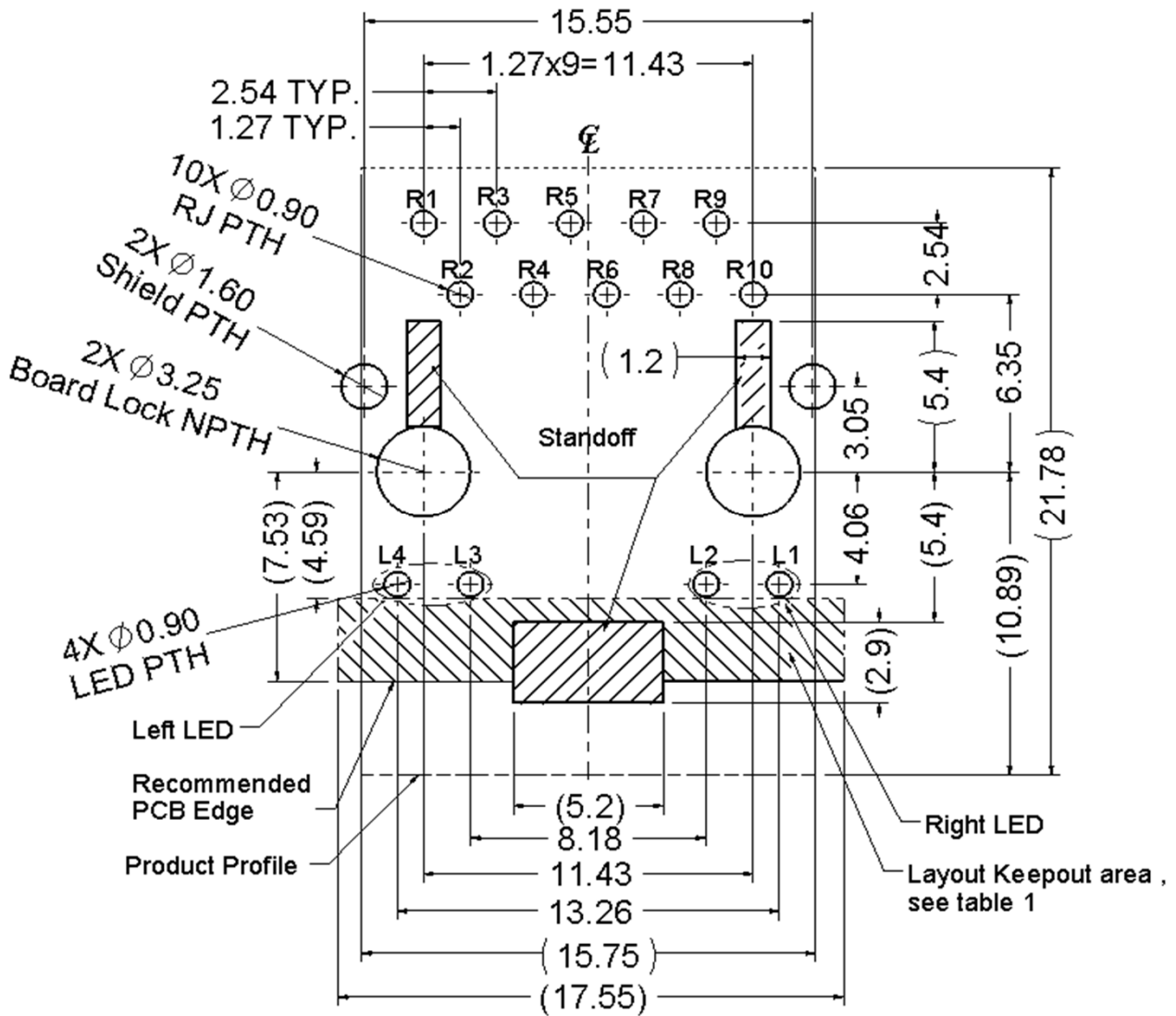
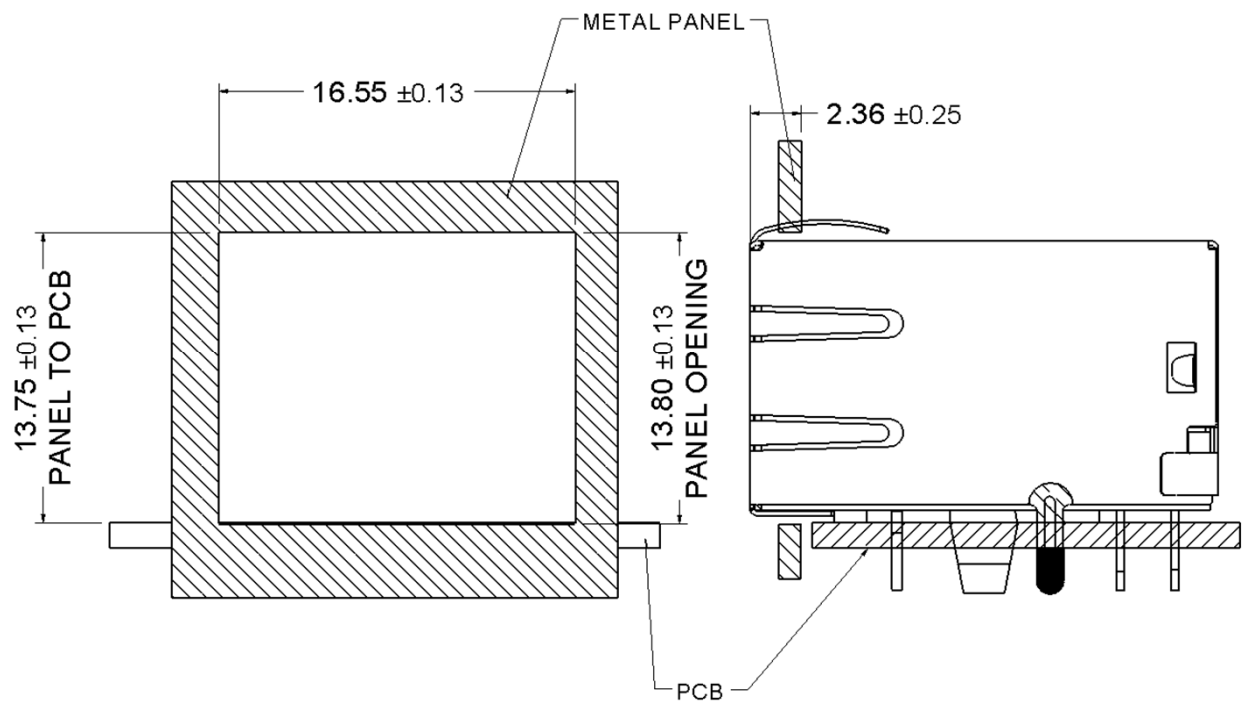

Table1

Layer \ Layout	Trace	component	Grounding	Test Point	Via Hole	PTH	NPTH
Component side	X	X	O	X	X	X	O
Inner layer	O	NA	O	NA	O	X	O
Bottom side	O	O	O	O	O	X	O

X--Forbid; O--OK; NA--Not Applicable.

1.3 Recommended panel cutout



1.4 Standard RJ45 Plug Specification

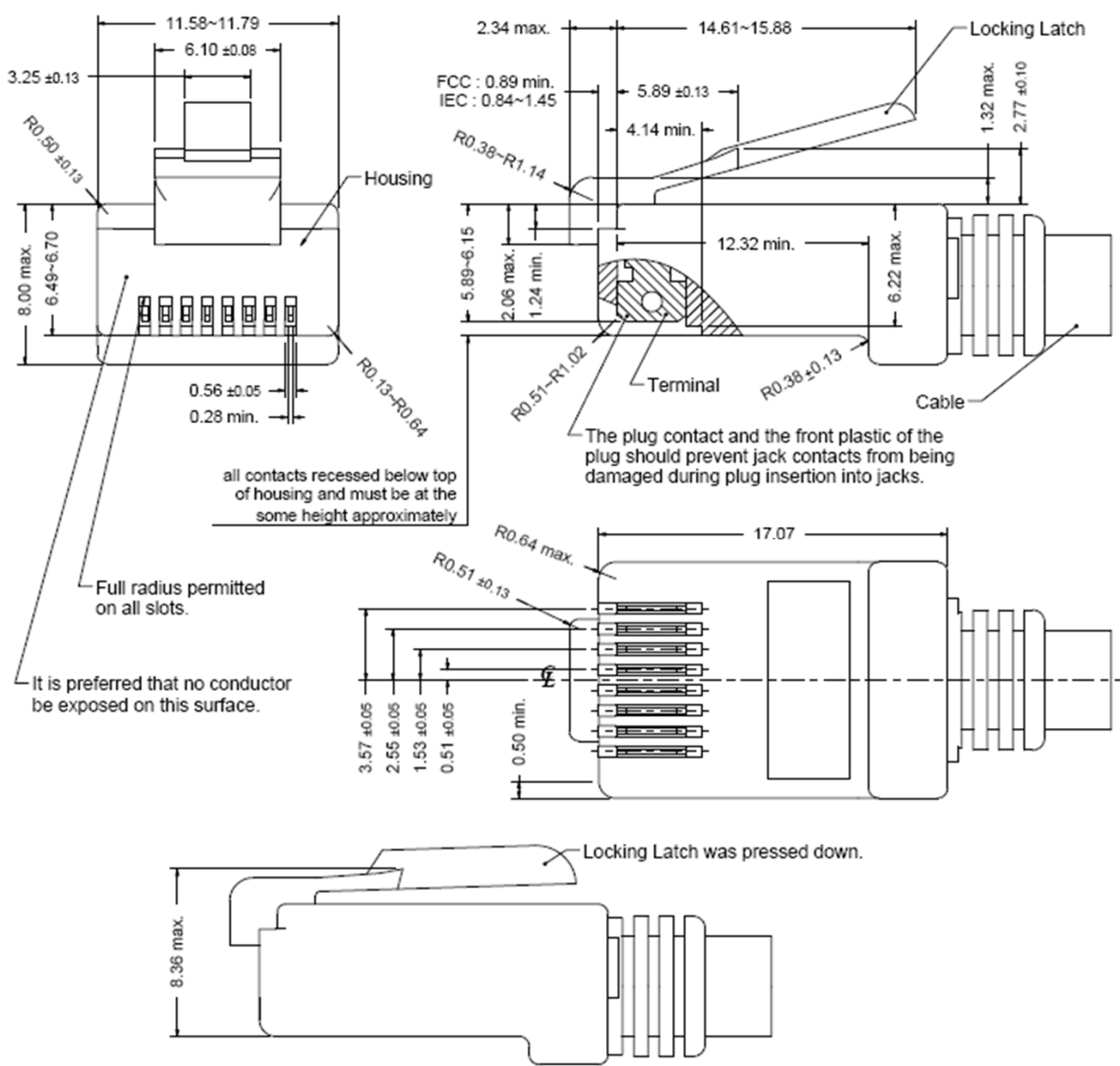

- All dimensions follow :
 - FCC subpart F, 68,500, Figure (C)(2)(i) & (C)(2)(ii) & (C)(3)(i)
 - IEC 60603-7
- All plugs must be meeting the requirements of plug Go & No-Go gauge.
 - Gauge follow : FCC subpart F, 68,500, Figure (C)(4)(i) & (C)(5)(i)
- There must be no damage to Housing and Locking Latch.
- There must be no nicks and cuts in cable.
- Durability : 750 cycles generally

2. REQUIREMENTS

2.1 Design and Construction

Product shall be of design, construction and physical dimensions specified on applicable.

2.2 Material

2.2.1 Terminal Parts (Underplating : 50 μ " min. Nickel overall)

2.2.1.1 RJ Terminal : Phosphor Bronze, Thickness=0.30mm

Finish : Contact Area : Gold Flash

2.2.1.2 Input Terminal : Brass, Thickness=0.35mm

Finish : 100 μ " min. Tin

2.2.1.3 Case Terminal : Brass, Thickness=0.30mm

Finish : 100 μ " min. Tin

2.2.2 Plastic Parts <UL94V-0>

2.2.2.1 Housing : PA6T, Black

2.2.2.2 Case : PA6T, Black

2.2.3 Shield Parts : Stainless, Thickness=0.20mm, Pre-soldering

2.3 Operating and Storage Temperature

Operating Temperature : 0°C to +70°C

Storage Temperature : -40°C to +85°C

2.4 RJ45 specifications

Insulation Resistance : 500MΩ min.

Insertion force with the latch depressed : 20N max

Removal force with the latch depressed : 20N max

Locking Force of Plug Latch : 50N min. @ 60+/-5 sec

Durability : 750 cycles

2.5 Performance and Test Description

Product is designed to meet electrical, mechanical and environmental performance requirements specified in below table. All tests are performed at ambient environmental conditions per MIL-STD-1344A and EIA-364 unless otherwise specified.

2.6 Packaging and Packing

All parts shall be packaged and packed to protect against physical damage 、 corrosion and deterioration during shipment and storage.

3. ELECTRICAL CHARACTERISTICS @ 25°C

3.1 Schematic

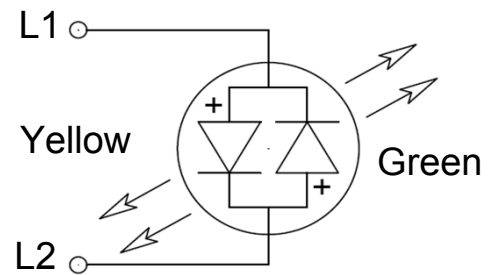
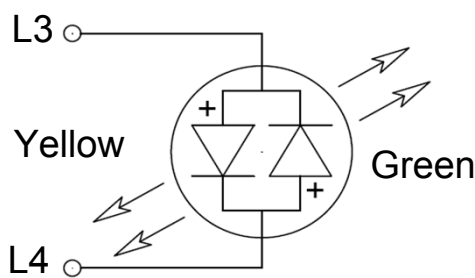
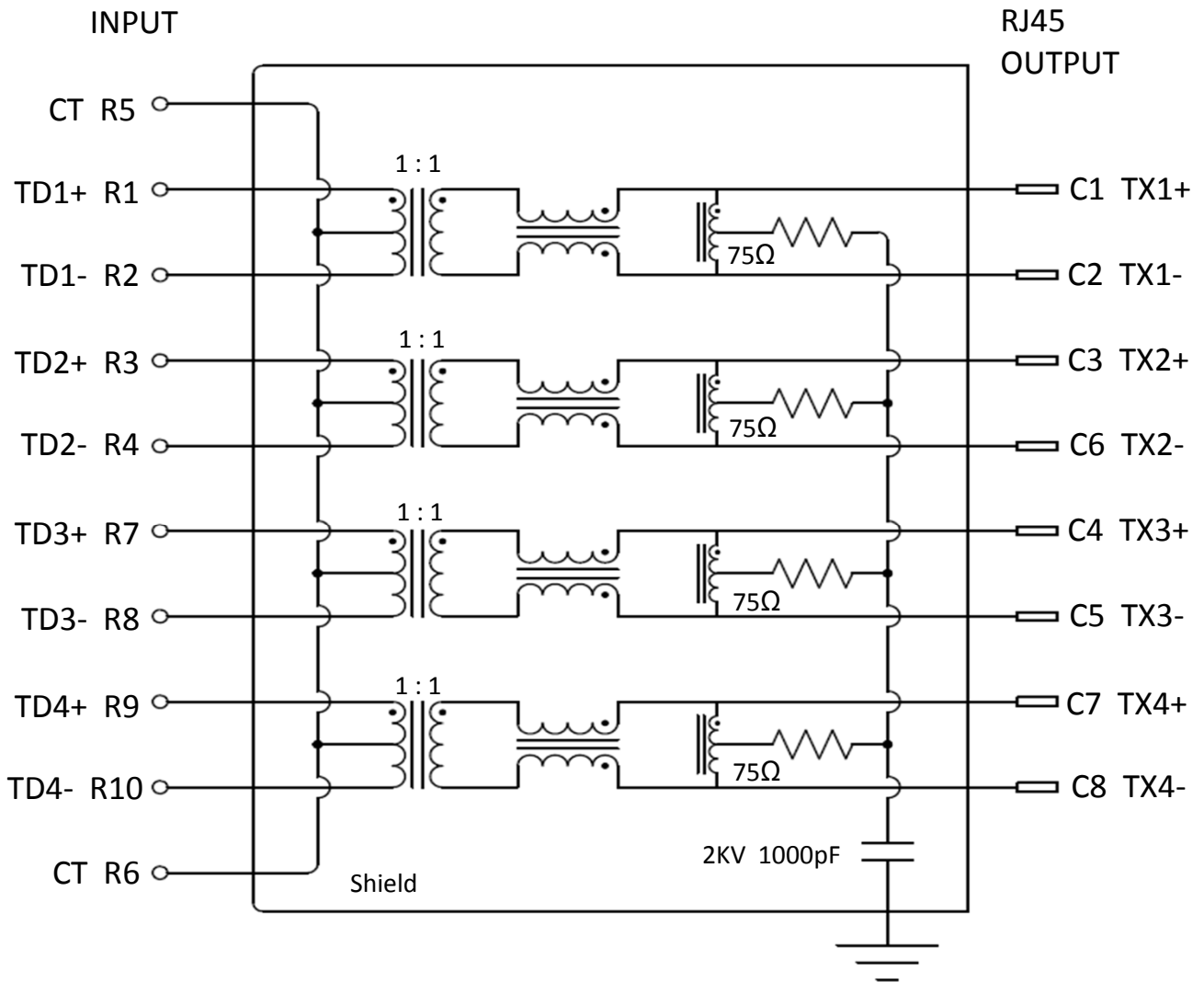

Emitting Color	λ_p (nm)	$V_f @ I_f=20mA$	$I_r @ V_r=5V$
Green	570	1.7 ~2.6 V	10 μ A max.
Yellow	588	1.7 ~2.6 V	10 μ A max.

3.2 Transmitter filter & Receiver filter

Type : Balance low pass 100Ω impedance

Insertion loss : 1~100 MHz -1.0dB max.

100~125 MHz -1.2dB max.

Return loss : 1~30 MHz -18dB min. load 100Ω

30~60MHz -16dB min. load 100Ω

60~80MHz -12dB min. load 100Ω

80~100MHz -10dB min. load 100Ω

3.3 Common Mode Rejection

@ 1~100 MHz -30dB min.

3.4 Cross Talk

@ 1~100 MHz -30dB min.

3.5 Inductance @ 100KHz, 0.1V, 8mA DC BIAS

Input (R1-R2), Input(R3-R4), Input (R7-R8), Input(R9-R10): 350 μH min.

3.6 Hi-Pot Test

Input(R1-R2) To Output(C1-C2) : 1500Vac 60s or 2250Vdc 60s

Input(R3-R4) To Output(C3-C6) : 1500Vac 60s or 2250Vdc 60s

Input(R7-R8) To Output(C4-C5) : 1500Vac 60s or 2250Vdc 60s

Input(R9-R10) To Output(C7-C8) : 1500Vac 60s or 2250Vdc 60s

4. ORDER INFORMATION

R B 1 - 2 S 5B AK1 A
 A B C D

A. LED Code :

L-Green/Yellow;R-Green/Yellow. <Refer to Schematic of LED>

B. Mechanical Code :

w/ UDE Logo, All Spring

C. Schematics Code :

AK1 : AK1 circuit

D. Plating Code :

Underplating	50 μ " min. Nickel overall	
Solder Tail	100 μ " min. Bright Tin	100 μ " min. Matted Tin
Contact Area	<u>A : Gold Flash</u> C : 6 μ " gold B : 10 μ " gold D : 15 μ " gold F : 30 μ " gold G : 50 μ " gold	1 : Gold Flash 6 : 6 μ " gold 2 : 15 μ " gold 3 : 30 μ " gold 4 : 50 μ " gold

5. WAVE SOLDERING TEMPERATURE PROFILE

Note :

The measuring point for the specified temperature shall be on the soldered part of the lead.

