

Limit Alarms (potentiometer adj.) A-UNIT

POTENTIOMETER ALARM

Functions & Features

- Providing SPDT relay outputs at preset potentiometer or slidewire positions
- Dual (Hi/Lo) trip
- Constant voltage excitation allows use with pots with total resistances from 100 Ω - 10 kΩ without affecting accuracy
- 50 % zero/span adjustments with minimal interaction
- Energized or de-energized coil at a tripped condition selectable
- Hysteresis (deadband) adjustable
- Enclosed relays
- Relays can be powered 110 V DC
- High-density mounting

Typical Applications

- Annunciator
- Various alarm applications

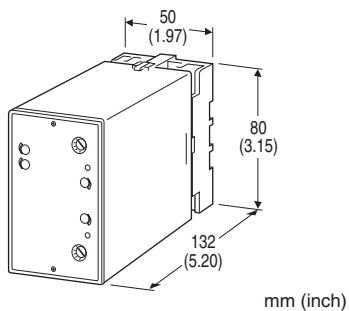

MODEL: APOT-1[1][2]-[3][4]

ORDERING INFORMATION

- Code number: APOT-1[1][2]-[3][4]
- Specify a code from below for each of [1] through [4].
(e.g. APOT-113-B/Q)
- Specify the specification for option code /Q
(e.g. /C01/S01)

INPUT POTENTIOMETER

Total resistance 100 Ω - 10 kΩ

SETPOINT ADJUSTMENTS

- 1: Single-turn screws

[1] SETPOINT 1 OUTPUT

- 1: Hi (coil energized at alarm)
- 2: Hi (coil de-energized at alarm)
- 3: Lo (coil energized at alarm)
- 4: Lo (coil de-energized at alarm)

[2] SETPOINT 2 OUTPUT

- 1: Hi (coil energized at alarm)
- 2: Hi (coil de-energized at alarm)
- 3: Lo (coil energized at alarm)
- 4: Lo (coil de-energized at alarm)

[3] POWER INPUT

AC Power

- B: 100 V AC
- C: 110 V AC
- D: 115 V AC
- F: 120 V AC
- G: 200 V AC
- H: 220 V AC
- J: 240 V AC

DC Power

- S: 12 V DC
- R: 24 V DC
- V: 48 V DC
- P: 110 V DC

[4] OPTIONS

- blank: none
- /Q: With options (specify the specification)

SPECIFICATIONS OF OPTION: Q (multiple selections)

COATING (For the detail, refer to M-System's web site.)

- /C01: Silicone coating
- /C02: Polyurethane coating
- /C03: Rubber coating

TERMINAL SCREW MATERIAL

- /S01: Stainless steel

GENERAL SPECIFICATIONS

Construction: Plug-in

Connection: M3.5 screw terminals

Screw terminal: Chromated steel (standard) or stainless steel

Housing material: Flame-resistant resin (black)

Isolation: Input to output 1 to output 2 to power

Zero adjustment: 0 - 50 % of total resistance (front)

Span adjustment: 50 - 100 % of total resistance (front)

Setpoint adjustments: 270°-turn screwdriver adjustments (front); 0 - 100 % independently

Hysteresis (deadband) adjustments: 1 - 100 % (front)
Front LEDs: LED turns on at a tripped condition; red for output 1, green for output 2
Power ON timer: Relays de-energized for approx. 2 seconds after power is turned on.

Response time: ≤ 0.5 sec. (0 - 100 % at 90 % setpoint)
Line voltage effect: ± 0.1 % over voltage range
Insulation resistance: ≥ 100 M Ω with 500 V DC
Dielectric strength: 2000 V AC @1 minute (input to output 1 to output 2 to power to ground)

INPUT SPECIFICATIONS

Minimum span: 50 % of total resistance
Excitation: 0.5 V DC

OUTPUT SPECIFICATIONS

■ **Relay Contact:** 100 V AC @ 1 A ($\cos \phi = 1$)
 120 V AC @ 1 A ($\cos \phi = 1$)
 240 V AC @ 0.5 A ($\cos \phi = 1$)
 30 V DC @ 1 A (resistive load)
Maximum switching voltage: 380 V AC or 125 V DC
Maximum switching power: 120 VA or 30 W
Minimum load: 5 V DC @ 10 mA
Mechanical life: 5×10^7 cycles
 For maximum relay life with inductive loads, external protection is recommended.

Alarm Trip Operation Terminal No. in parentheses

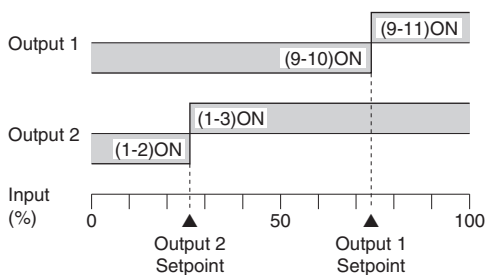

Trip Operation in Power Failure

- **Output Code: 1 & 4:** Terminals 1 - 2, 9 - 10 turn ON
- **Output Code: 2 & 3:** Terminals 1 - 3, 9 - 11 turn ON

INSTALLATION

Power input

- **AC:** Operational voltage range: rating ± 10 %, 50/60 ± 2 Hz, approx. 2 VA
- **DC:** Operational voltage range: rating ± 10 %, or 85 - 150 V for 110 V rating (ripple 10 % p-p max.) approx. 2 W (80 mA at 24 V)

Operating temperature: -5 to +60°C (23 to 140°F)

Operating humidity: 30 to 90 %RH (non-condensing)

Mounting: Surface or DIN rail

Weight: 450 g (0.99 lb)

PERFORMANCE in percentage of span

Trip point repeatability: ± 0.5 %

Temp. coefficient: ± 0.05 %/°C (± 0.03 %/°F)

EXTERNAL VIEW

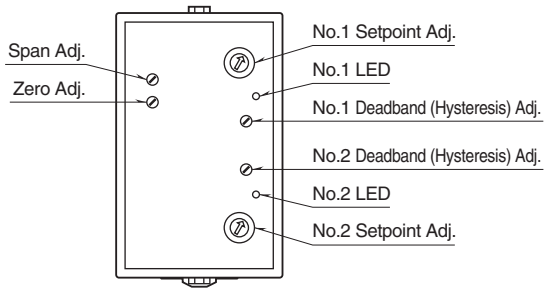

EXTERNAL DIMENSIONS & TERMINAL ASSIGNMENTS unit: mm (inch)

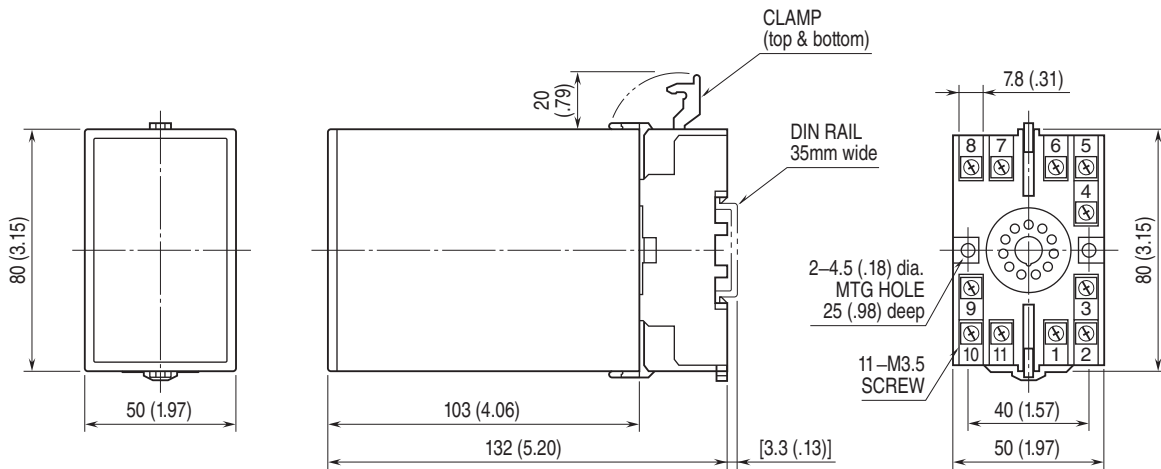

• When mounting, no extra space is needed between units.

SCHEMATIC CIRCUITRY & CONNECTION DIAGRAM

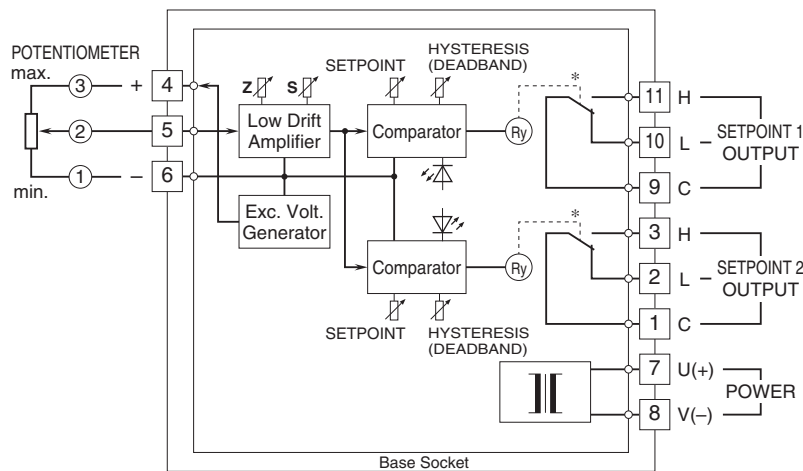

*Relay status for output codes "1" & "4", at power OFF.

■ Relay Protection

• AC Powered

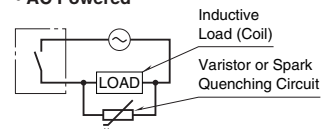

• DC Powered

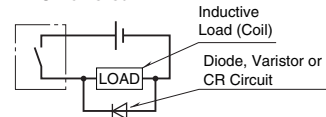

Specifications are subject to change without notice.