

GOT5840T-834

8.4" SVGA TFT Fanless Touch Panel
Computer with Intel® Celeron® Processor
J1900 (up to 2.42 GHz)

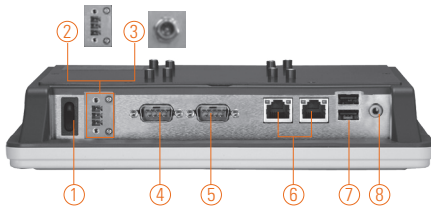

- | | |
|--|---------------------|
| 1. Power switch (ATX) | 6. Ethernet x 2 |
| 2. Terminal block for DC power input or
or 3. Screw conn. w/ AC power adapter | 7. USB 3.0 x 2 |
| 4. COM 1 (RS-232/422/485) | 8. Audio (Line-out) |
| 5. COM 2 (RS-232/422/485) | |



Introduction

The GOT5840T-834 is a 8.4" Intel® Celeron® based fanless touch panel computer. In response to market demand, this panel computer is a cost effective solution. It adopts a modern, super sleek and fanless design and is equipped with a 8.4" TFT LCD as well as Intel® Celeron® processor J1900 (Bay Trail). For wireless network connection, the GOT5840T-834 offers 2 mini card slots. By just plugging in the mini card WLAN card, customers can have instant access to wireless LAN/GPRS/GSM/4G environments. Besides, it provides two types of power input. One is DC power input (9-36VDC) with terminal block connector, and another is AC power adapter with screw type connector.

Super slim & ultra lightweight design

The GOT5840T-834 is a super slim touch panel computer for space-limited environment with its thickness of 45 mm and weight of 1.3 kg only, which make it installed everywhere.

Built-in internal WLAN antenna

The GOT5840T-834 provides 2 PCIe Mini Card slots and a built-in WLAN antenna for wireless network connections. By simply plugging in the wireless LAN card, customers can use the GOT5840T-834 in a wireless LAN/GPRS/GSM/4G environments.

Excellent thermo solution: aluminum back chassis

With Axiomtek's patent for plastic plus aluminum mechanism design, the GOT5840T-834 can dissipate the heat easily and keep the system operation stable.

Features

- 8.4" SVGA TFT LCD display with LED backlight
- Fanless cooling system with Intel® Celeron® processor J1900 (up to 2.42 GHz)
- Ultra slim and super light design
- Supports WLAN module & internal antenna
- Easy for expansion: PCIe Mini Cards
- Supports 2 Gigabit LAN, 2 USB & 2 COM ports
- Supports panel mount, wall mount, VESA arm and desktop stand
- Plastic and IP65-rated front bezel



▲ Side view



▲ Desktop stand

Specifications

Front Bezel	IP65, NEMA 4 rugged protection, plastic front bezel	
LCD Panel	Display Type	8.4" SVGA TFT LCD with LED backlight
	Brightness (cd/m ²)	350 nits
	Resolution	800 x 600
	Viewing Angel (H/V)	160°/140°
Main System	CPU	Intel® Celeron® processor J1900 4 cores (up to 2.42 GHz)
	System Memory	1 x 204-pin DDR3L-1333 MHz SO-DIMM max. up to 8 GB
	BIOS	AMI UEFI BIOS
	Storage	1 x CFast™ or mSATA
	Watchdog Timer	255 levels, 0-255 sec.
	Onboard Graphics	Integrated in Intel® GFX



Specifications

I/O Connector	2 x RS-232/422/485 (default RS-232, COM 1/2) 2 x USB 3.0 2 x 10/100/1000Mbps Ethernet (Intel® i210IT) 1 x Audio (Line-out)
Expansion Interface	1 x Full-size PCI Express Mini Card with mSATA 1 x Full-size PCI Express Mini Card with SIM slot
Touchscreen	Resistive type
Power Input	1. DC version: 9-36VDC with over-current protection fuse 2. AC version: 100-240V AC-DC 60W power adapter
Dimensions	250.7 mm (9.87") (W) x 45.8 mm (1.80") (D) x 204.7 mm (8.06") (H)
Packing Dimensions	380 mm (14.96") (W) x 100 mm (3.94") (D) x 280 mm (11.02") (H)
Weight (net/gross)	1.3 kg (2.87 lb)/ 2.25 kg (4.96 lb)
Environment	Operating temperature: 0° ~ +50°C (+32°F ~ +122°F) (with W.T. DRAM/HDD in airflow condition) 0° ~ +45°C (+32°F ~ +113°F) (with W.T. DRAM) Storage Temperature: 0° ~ +50°C (+32°F ~ +122°F) (in airflow condition) Relative humidity: 20% ~ 90% @ 40°C; non-condensing Operation vibration: 2G, 5-500Hz, random for CFast™
Certificate	CE

Ordering Information

GOT5840T-834-J	8.4" SVGA fanless touch panel computer with Intel® Celeron® processor J1900, 5-wire resistive touch screen, AC-DC 60W power adapter (screw type connector) and EMI class B
GOT5840T-834-DC	8.4" SVGA fanless touch panel computer with Intel® Celeron® processor J1900, 5-wire resistive touch screen and 9-36VDC power input (terminal block connector)

* Specification and certifications are based on options and may vary.

Optional EOS Installation

WES 7

WE8S

Optional OS Installation

Windows® 7

Windows® 8.1



Dimensions

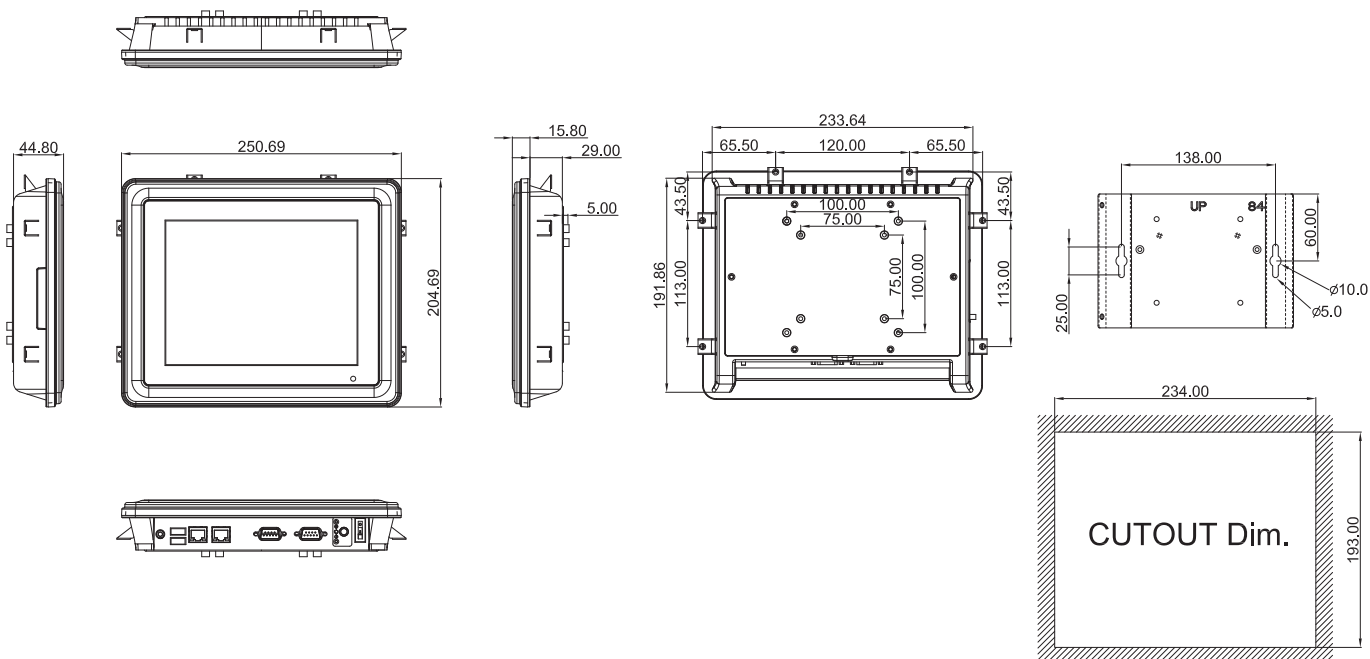

Overview

1
Fanless Touch Panel Computers

Heavy-duty Fanless Touch Panel Computers

Industrial Touch Panel Computers

Industrial Touch panel Monitors

Infotainment Touch Panel Computers

Healthcare & Medical Solutions

Open Frame Panel Computers

Accessories

