

MTFH, MTFS, and MTFZ Series



- Standard 14 Dip/4 Package
- RoHS Compliant Available
- Stability Available to ± 1 ppm
- Operating Voltage +3.3VDC or +5.0VDC
- Wide Frequency Range



ELECTRICAL SPECIFICATIONS:

Output	HCMOS	Clipped Sinewave	Sinewave
Frequency Range	1.000MHZ to 160.000MHZ	8.000MHZ to 160.000MHZ	8.000MHZ to 160.000MHZ
Load	10k Ohms // 15pF	10k Ohms // 15pF	50 Ohms
Supply Current	35mA max	3mA max	25mA max
Output Level	Logic "1" = 90% of Vdd min Logic "0" = 10% of Vdd max	1.0V p-p min	7 dBm
Symmetry	40%/60% at 50% of Waveform	N/A	N/A
Freq. Stability vs Temp (Note 1)	(See Frequency Stability vs Temperature Table)		
Freq. Stability vs Aging	± 1 ppm per year max		
Freq. Stability vs Voltage	± 0.3 ppm with a 5% change in Vdd		
Freq. Stability vs Load	± 0.3 ppm with a 10% change in Load		
Operating Range	(See Frequency Stability vs Temperature Table)		
Storage Temperature	-40°C to +85°C		
Supply Voltage (Vdd)	+3.3VDC $\pm 5\%$	+5.0VDC $\pm 5\%$	
Control Voltage with VC option	+1.65VDC ± 1.50 VDC Positive Slope	+2.50VDC ± 2.00 VDC Positive Slope	

Pin 1 Connection	
No Connection	No Connection
VC Option	± 10 ppm min

Note 1: Oscillator frequency shall be ± 1 ppm at +25°C ± 3 °C at time of shipment.

PART NUMBER GUIDE:

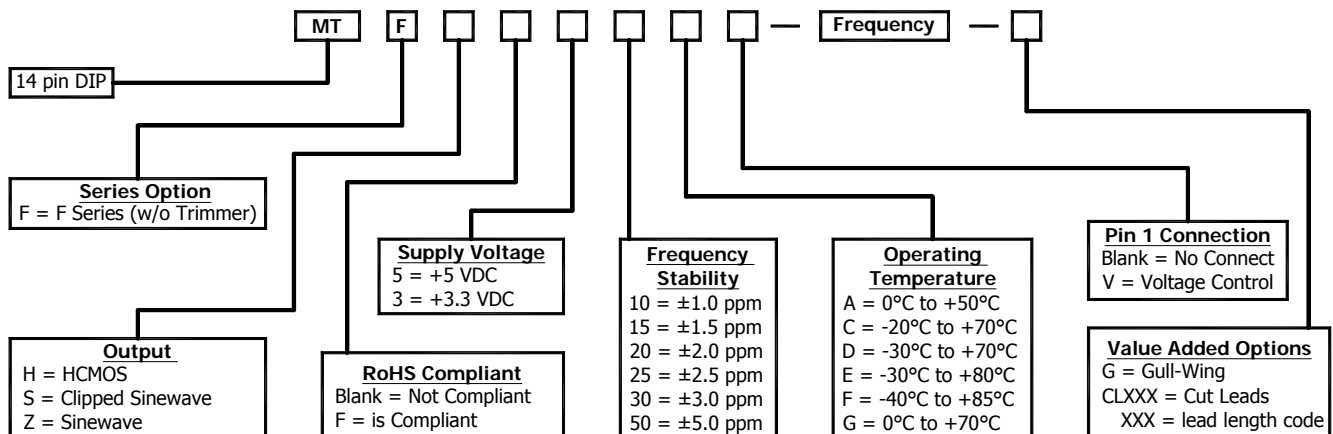

Please Consult with MMD Sales Department for any other Parameters or Options

MMD Components, 30400 Esperanza, Rancho Santa Margarita, CA, 92688

Phone: (949) 709-5075, Fax: (949) 709-3536, www.mmdcomp.com

Sales@mmdcomp.com

FREQUENCY STABILITY vs TEMPERATURE TABLE:

Code	Stability	10	15	20	25	30	50
	Temp	±1.0ppm	±1.5ppm	±2.0ppm	±2.5ppm	±3.0ppm	±5.0ppm
A	0°C TO +50°C	●	●	●	●	●	●
G	0°C TO +70°C	□	●	●	●	●	●
C	-20°C TO +70°C	□	□	●	●	●	●
D	-30°C TO +70°C	□	□	□	●	●	●
F	-40°C TO +85°C	□	□	□	●	●	●

● = Available

□ = Consult with the Manufacturer

MECHANICAL DIMENSIONS:

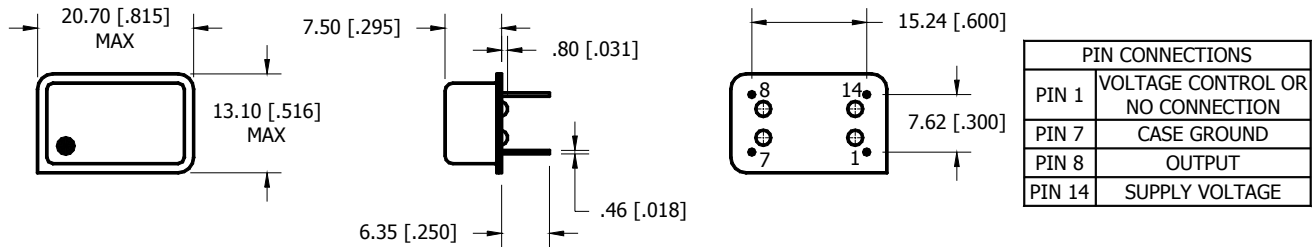

DIMENSIONS IN BRACKERS ARE IN INCHES
EXTERNAL BYPASS CAPACITOR IS RECOMMENDED

ENVIRONMENT / MECHANICAL:

Shock	MIL-STD-883, Method 2002, Condition B
Solderability	MIL-STD-883, Method 2003
Solvent Resistance	MIL-STD-202, Method 215
Vibration	MIL-STD-883, Method 2007, Condition A
Gross Leak Test	MIL-STD-883, Meth 1014, Cond C
Fine Leak Test	MIL-STD-883, Meth 1014, Cond A

MARKING:

Line 1 = MXXXXX

M = MMD COMPONENTS
XXXXX = Frequency in MHZ

Line 2 = SYMMML

S = Internal Code
YYMM = 4 Digit Date Code (Year / Month)
L = Denotes RoHS Compliant

Line 3 = XXXXX

Internal use only
May vary with lots

Black dot to denote Pin 1

PHASE NOISE:

PHASE NOISE PLOT
COMING SOON

MMD Components, 30400 Esperanza, Rancho Santa Margarita, CA, 92688
Phone: (949) 709-5075, Fax: (949) 709-3536, www.mmdcomp.com
Sales@mmdcomp.com

