

RL-4010

SHIELDED SMD POWER INDUCTOR

DESCRIPTION

- Shielded SMD Power Inductor

ENVIRONMENTAL DATA

- Storage temperature range: -55°C to +130°C
- Operating temperature range: -40°C to +130°C

PACKAGING INFORMATION

- Packaging information: pg. 489

FEATURES & APPLICATIONS

- Surface mount power inductor in a small package
- Easy use for pick and place operations
- Excellent as a power inductor used in notebook computers, smartphones, cell phones, step-up or step-down converters, and Flash memory
- Available in 11 values with inductance ratings from 1.0 μH to 47.0 μH and currents up to 1.40 A

Verify operation with sample in actual circuit. Order samples at www.rencousa.com.

MECHANICAL DIMENSIONS

U.S. Standard (mm)

PART NUMBER	A (MAX.)	B (MAX.)	C (MAX.)	D (TYP.)	E (TYP.)	F (TYP.)	G (TYP.)
RL-4010	0.17 (4.30)	0.17 (4.30)	0.039 (1.00)	0.082 (2.10)	0.037 (0.96)	0.062 (1.60)	0.043 (1.10)

PART NUMBER	PART WEIGHT	H (REF.)	I (REF.)	J (REF.)	K (REF.)	L (REF.)	M (REF.)
RL-4010	0.9g (0.03oz)	0.173 (4.40)	0.078 (2.00)	0.078 (2.00)	0.165 (4.20)	0.169 (4.30)	0.039 (1.00)

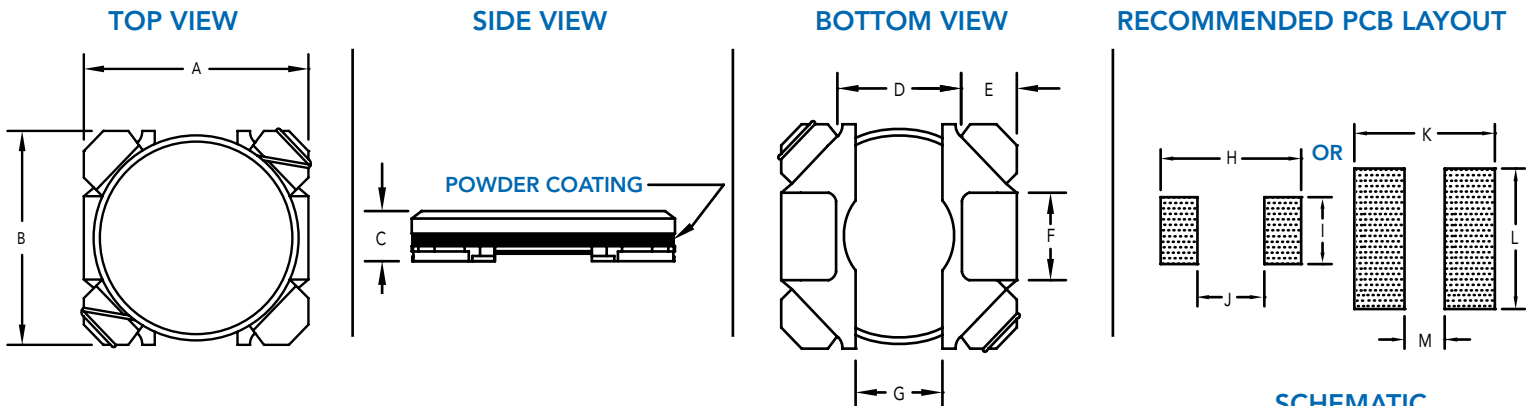

SCHEMATIC

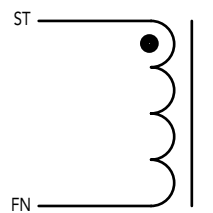

RENCO ELECTRONICS INC.

595 International Place, Rockledge, FL 32955-4200 USA • www.rencousa.com • ISO 9001 Certified
Toll Free Engineering Hot Line: 800.645.5828 • P: 321.637.1000 • F: 321.637.1600



RL-4010

Renco Part No. RL-4010	Inductance (μ H)	DCR Max. (Ohms)	Isat (A)	Irms (A)
RL-4010-1R0N	1.0 \pm 30%	0.056	1.40	1.70
RL-4010-1R5N	1.5 \pm 30%	0.072	1.20	1.60
RL-4010-2R2N	2.2 \pm 30%	0.084	1.10	1.55
RL-4010-3R3N	3.3 \pm 30%	0.110	0.90	1.35
RL-4010-4R7M	4.7 \pm 20%	0.160	0.80	1.15
RL-4010-6R8M	6.8 \pm 20%	0.230	0.65	0.90
RL-4010-100M	10.0 \pm 20%	0.310	0.50	0.75
RL-4010-150M	15.0 \pm 20%	0.410	0.45	0.65
RL-4010-220M	22.0 \pm 20%	0.660	0.40	0.50
RL-4010-330M	33.0 \pm 20%	0.960	0.30	0.38
RL-4010-470M	47.0 \pm 20%	1.230	0.25	0.33

NOTES:

1. Isat - DC CURRENT THAT WILL CAUSE INDUCTANCE TO DROP BY 30%
2. Irms - CURRENT THAT CAUSES THE TEMPERATURE TO RISE APPROX. 40°C ABOVE AMBIENT OF 25°C
3. ELECTRICAL SPECIFICATIONS MEASURED AT 25°C
4. RESISTANCE TO SOLDER HEAT: 260°C FOR 10 SECONDS
5. INDUCTANCE TESTED AT 100 kHz, 0.1 Vrms



RENCO ELECTRONICS INC.

595 International Place, Rockledge, FL 32955-4200 USA • www.rencousa.com • ISO 9001 Certified
Toll Free Engineering Hot Line: 800.645.5828 • P: 321.637.1000 • F: 321.637.1600

