

## FEATURES

- 85 Watt power rating at 25°C case temperature
- Non-inductive performance
- Low thermal resistance
- RoHS compliant design
- Two or three terminals versions available
- Heat sink can be grounded through middle terminal (P style)

## SPECIFICATIONS

**Material**  
**Resistor:** thick film on alumina  
**Lead:** solder coated phosphor bronze  
**Solder:** 100% Sn  
**Case:** high temperature plastic  
**P Package:** middle terminal is electrically connected to header and insulated from left and right terminals  
**M Package:** no middle terminal

**Electrical**  
**Resistance range:** 2Ω-10KΩ  
**Max. working voltage:** 500V or Ohm's law limited  
**Thermal Resistance:** 1.47°C/W  
**Temperature Coefficient:**  
 2Ω-10Ω: ±100ppm  
 10Ω-10KΩ: ±50ppm  
**Insulation Resistance:** 400MΩ  
**Short time overload:** 2x rated power (not to exceed 1500V)  
**Derating:** linear, 100% at 25°C to 0% at 150°C



# TFH Series

## 85 Watt T0264 Package Thick Film Power

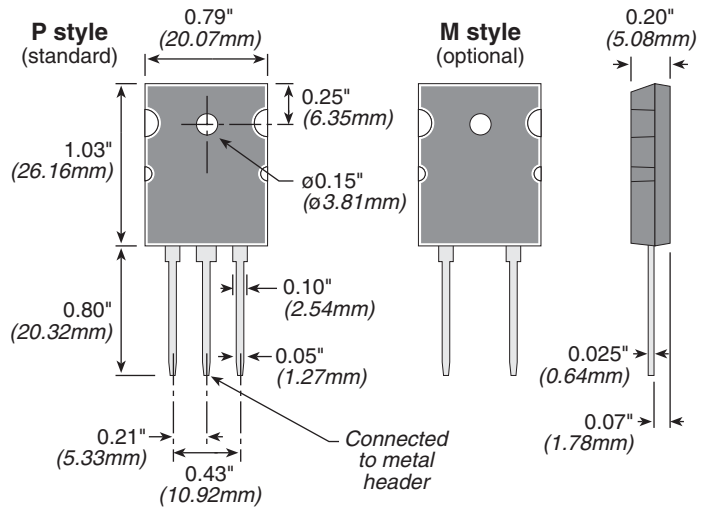

## DERATING

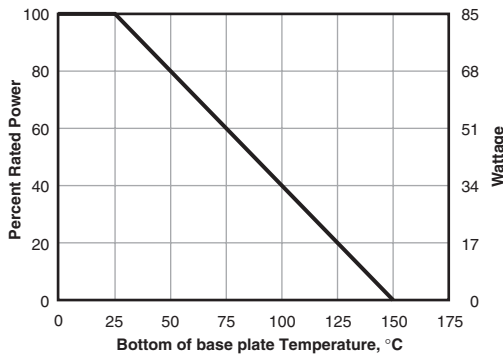

## ORDERING INFORMATION

**Package Code**  
 P = three terminals  
 M = two terminals  
 RoHS compliant

**TFH85P10R0JE**

**Series**      **Ohms**      **Tolerance**  
 R = Decimal  
 Example:  
 10R2 = 10.2 ohms  
 100R = 100 ohms  
 10K0 = 10,000 ohms

## PERFORMANCE DATA

<b>Load life</b>	1000 hrs @ rated power	max. ΔR ±1%
<b>Moisture resistance</b>	MIL-STD-202, method 106	max. ΔR ±0.5%
<b>Short time overload</b>	2x rated power for 5 sec., not to exceed 1500 V	max. ΔR ±0.3%
<b>Solderability</b>	MIL-STD-202, method 208	
<b>Thermal shock</b>	MIL-STD-202, method 170, cond. F	max. ΔR ±0.2%

## THIS PRODUCT IS DESIGNED FOR USE WITH PROPER HEATSINKING.

Maximum base plate temperature of the resistor must be monitored and kept within specified limits to establish the power rating. Best technique is to attach a thermocouple to the side of the base plate of the resistor. Temperature of plastic housing or heat sink cannot be used to establish rating of the resistor.

To see the latest in resistor technology click on the "What's New" tab at [ohmite.com](http://ohmite.com)

## STANDARD PART NUMBERS FOR TFH SERIES

Ohms	P-type 3-terminal	M-type 2-terminal
2	TFH85P2R00JE	
3		TFH85M3R00JE
5.1	TFH85P5R10JE	
6.8		TFH85M6R80JE
7.5	TFH85P7R50JE	
10	TFH85P10R0JE	TFH85M10R0JE
15	TFH85P15R0JE	
24		TFH85M24R0JE
33		TFH85M33R0JE
39	TFH85P39R0JE	
51	TFH85P51R0JE	TFH85M51R0JE
68	TFH85P68R0JE	
75	TFH85P75R0JE	
100	TFH85P100RJE	TFH85M100RJE
150		TFH85M150RJE
220	TFH85P220RJE	
330	TFH85P330RJE	
470		TFH85M470RJE
750	TFH85P750RJE	
1000	TFH85P1K00JE	TFH85M1K00JE
1500	TFH85P1K50JE	
2700		TFH85M2K70JE
3300	TFH85P3K30JE	
4700		TFH85M4K70JE
6800	TFH85P6K80JE	
7500	TFH85P7K50JE	
10000	TFH85P10K0JE	TFH85M10K0JE

Check product availability at [www.ohmite.com](http://www.ohmite.com)