



The Future of Analog IC Technology®

# EV3352DQ-00A

## Integrated Photo Flash Charger IGBT Driver EV Board

### DESCRIPTION

The EV3352DQ-00A is an evaluation board for the MP3352, a fast, highly efficient and precision high voltage photo-flash charger for xenon flash applications.

The programmable peak current is up to 2.5A to ensure fast charging time. 200mΩ internal power switch minimizes the conduction loss. 55V maximum SW operating voltage lowers transformer turns ratio and switching loss associated with the primary leakage inductance.

The board offers charge-ready indicator, quench function, flash mode, red-eye reduction + flash mode.

### ELECTRICAL SPECIFICATIONS

Parameter	Symbol	Value	Units
Input Voltage	V <sub>IN</sub>	3 – 8	V
Supply voltage	V <sub>CC</sub>	3 – 6	V
Peak charge current	I <sub>PEAK</sub>	2.5	A
Charge voltage	V <sub>OUT</sub>	300	V

### FEATURES

- Programmable Peak Current Up to 2.5A
- 3% Charge Accuracy
- Quench Function
- Charge-ready Indicator
- Microcontroller Controlled On/Off, Flash or Red Eye Reduction + Flash Mode
- Integrated IGBT Driver

### APPLICATIONS

- Digital Still Cameras
- Optical Film Cameras
- Mobile Phones With Camera
- PDAs With Camera

"MPS" and "The Future of Analog IC Technology" are Registered Trademarks of Monolithic Power Systems, Inc.

### EV3352DQ-00A EVALUATION BOARD



(L x W x H) 2.9" x 2.9" x 0.5"  
(7.5cm x 7.5cm x 1.2cm)

Board Number	MPS IC Number
EV3352DQ-00A	MP3352DQ

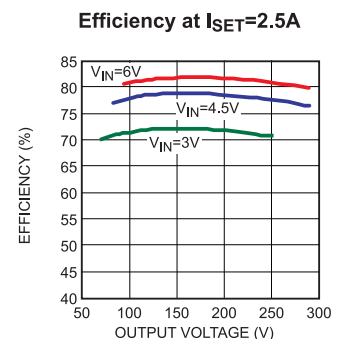
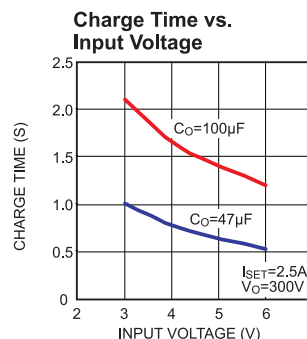

## EVALUATION BOARD SCHEMATIC

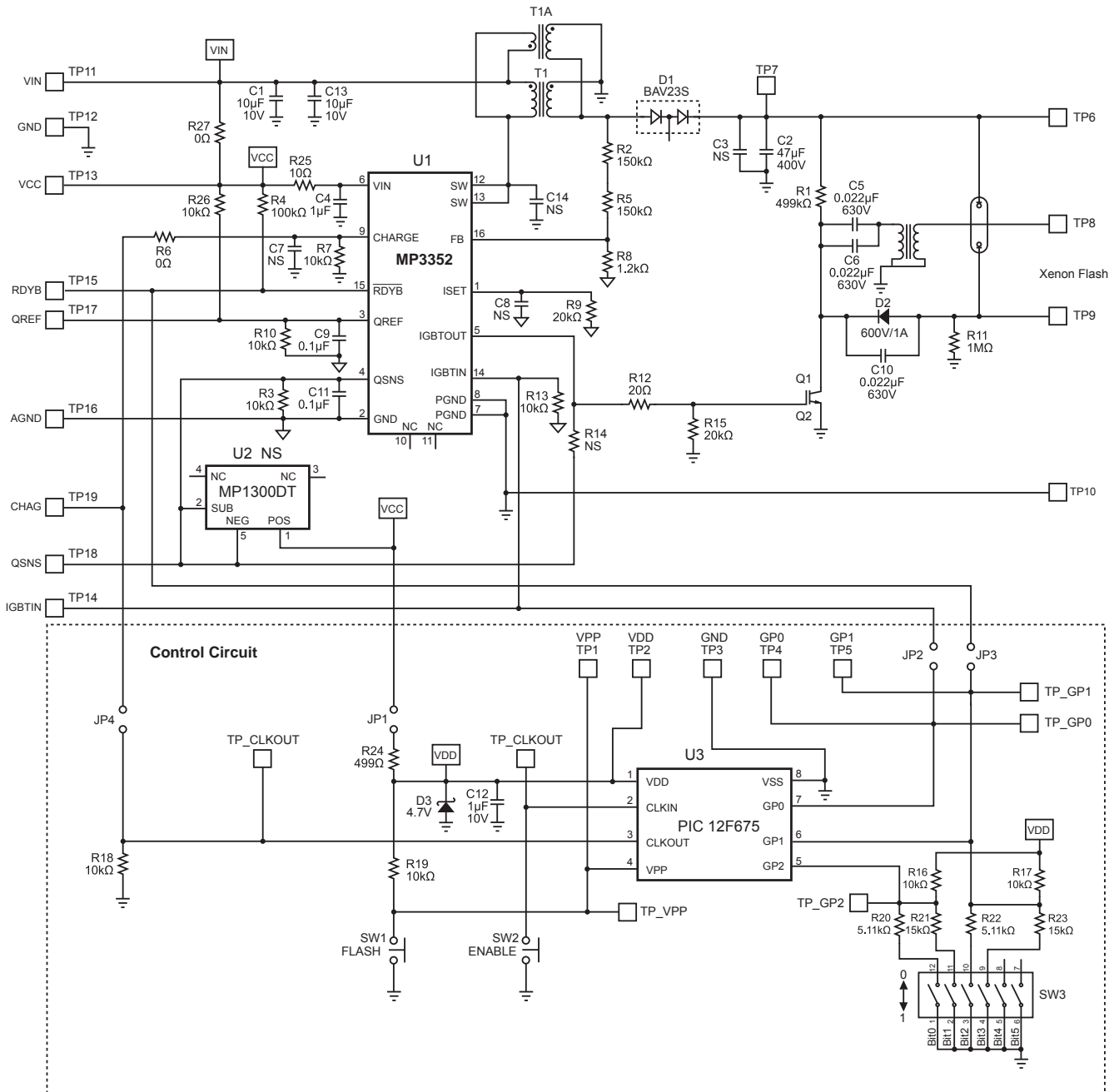

**EV3352DQ-00A BILL OF MATERIALS**

Qty	Ref	Value	Description	Package	Manufacturer	Manufacturer P/N
2	C1, C13	10 $\mu$ F	Ceramic Cap. 10V, X7R	1206	MuRata	GRM31CR71A106K
1	C2	47 $\mu$ F	El. Al. Cap. 400V, 20%	D16xL25	Panasonic	EEUED2G470
1	C4	1 $\mu$ F	Ceramic Cap. 10V, X7R	0603	MuRata	GRM188R71A105K
3	C5, C6, C10	22nF	Ceramic Cap. 630V, X7R	1206	TDK	C3216JB2J223K
4	C3, C7, C8, C14	NS	Not Stuffed	1206 0603 0805		
2	C9, C11	0.1 $\mu$ F	Ceramic Cap. 10V, X7R	0603	MuRata	GRM188R71A104K
1	R1	499k $\Omega$	Film Resistor, 1%	1206	Panasonic	ERJ-8ENF4993V
2	R2, R5	150k $\Omega$	Film Resistor, 1%	1206	Panasonic	ERJ-8ENF1503V
5	R3, R7, R10, R13, R26	10k $\Omega$	Film Resistor, 1%	0603	Panasonic	ERJ-3EKF1002V
1	R4	100k $\Omega$	Film Resistor, 1%	0603	Panasonic	ERJ-3EKF1003V
2	R6, R27	0 $\Omega$	Film Resistor, 5%	0603	Panasonic	ERJ-3GEY0R00V
1	R8	1.2k $\Omega$	Film Resistor, 1%	0603	Panasonic	ERJ-3EKF1201V
1	R9	20k $\Omega$	Film Resistor, 1%	0603	Panasonic	ERJ-3EKF2002V
1	R11	1M $\Omega$	Film Resistor, 1%	1206	Panasonic	ERJ-8ENF1004V
1	R12	20 $\Omega$	Film Resistor, 1%	0603	Panasonic	ERJ-3EKF20R0V
	R14	NS	Not Stuffed	0603		
1	R15	20k $\Omega$	Film Resistor, 1%	0603	Panasonic	ERJ-3EKF2002V
1	R25	10 $\Omega$	Film Resistor, 5%	0603	Panasonic	ERJ-3GEY10R0V
1	D1	250V/400 mA	Switching Diode	SOT-23	DIODES	BAV23S
1	D2	1A	Diode Switching 600V	SMA	VISHAY	RS1J-E3/61TGICT
1	Q1	400V	Flash N-Ch Logic IGBT	SSOT-8	Fairchild	FGR15N40A
1	Q2	NS	Not Stuffed	SO-8		
1	T1	NS	Not Stuffed			
1	T1A	T-19-060	Transformer	SM	TOKYO Coil	T-19-060
1	T2	BO-02	Transformer	SM	TOKYO Coil	BO-02
1	TP6~TP10	NS	Not Stuffed			
1	TP11~TP19		12-pin header, 2mm		SULLINS Elec.	PRPN121PAEN-RC
1	Flash	NS	Xenon Flash			
1	U1		Photo Flash Charger	QFN16 3x3mm	MPS	MP3352DQ
1	U2	NS	Not Stuffed			

**EV3352DQ-00A CONTROL CIRCUIT BOM**

Qty	Ref	Value	Description	Package	Manufacturer	Manufacturer P/N
1	U3	EEPROM	Data EEPROM Memory	SO8	MicroChip	PIC12F675
1	C12	1 $\mu$ F	Ceramic Cap., 10V, X7R	0805	MuRata	GRM21BR71A105K
4	R16, R17, R18, R19	10k $\Omega$	Film Resistor, 1%	0805	Panasonic	ERJ-6ENF1002V
2	R20, R22	5.11k $\Omega$	Film Resistor, 1%	0805	Panasonic	ERJ-6ENF5111V
2	R21, R23	15k $\Omega$	Film Resistor, 1%	0805	Panasonic	ERJ-6ENF1502V
1	R24	499 $\Omega$	Film Resistor, 1%	0805	Panasonic	ERJ-6ENF4990V
1	D3	4.7V	Zaener Diode 0.5W	SOD123	DIODES	BZT52C4V7
2	SW1, SW2	Switch	Push Switching button	SM 4x10mm	Digi-Key	P8002SCT-ND
1	SW3	6 pos	DIP Switching	DIP6	Digi-Key	CKN1290-ND
4	JP1~JP4	2-pin	2-pin Header, 2.54mm	2.54mm	Sullins	PTC02SAAN
3	JP1, JP2, JP4	2-pin	2-pin Jumper, 2.54mm			
0	JP3	NS	Not Stuffed			
1	TP1~TP5		5-pin Header, 2.54mm		Sullins	PTC05SAAN

**PRINTED CIRCUIT BOARD LAYOUT**

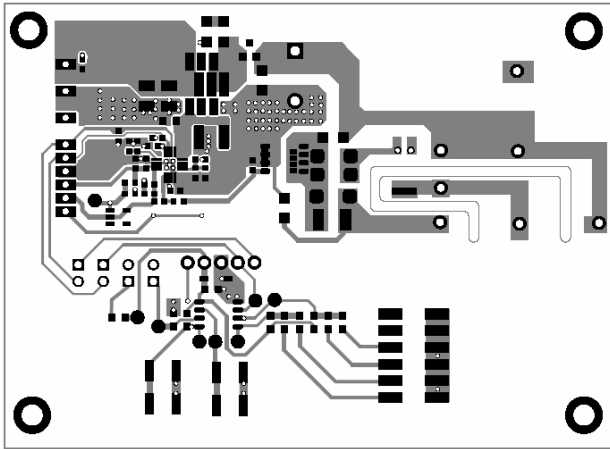

Figure 1—Top Layer

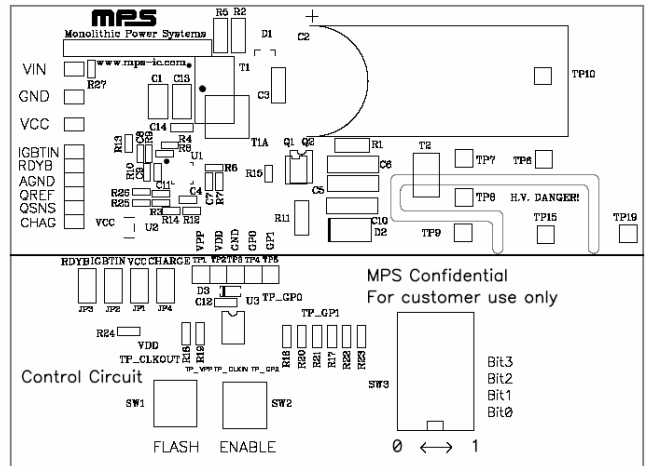

Figure 2—Top Silk Layer

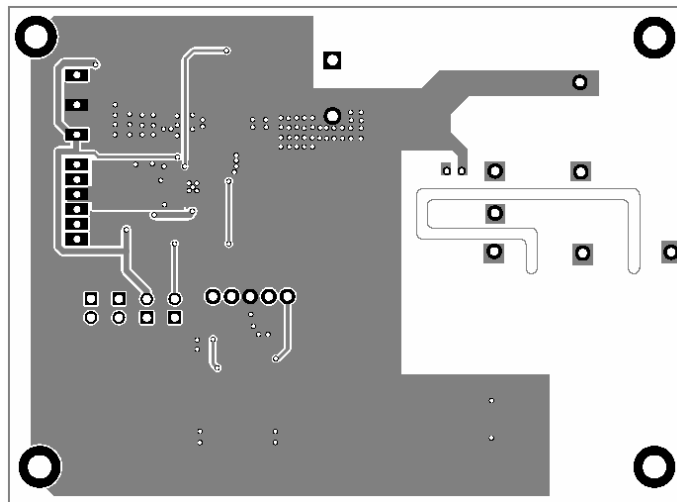

Figure 3—Bottom Layer

## QUICK START GUIDE

Note: Please remove R27 if wish to use two separate supplies ( $V_{IN}$  and  $V_{CC}$ ). Otherwise  $V_{CC}$  will be powered directly from  $V_{IN}$  and  $V_{IN-MAX}=6V$ !

1. Solder Q1, trigger coil-T2 and Xenon Flash tube to the board if they are not populated.
2. Turn off power supply.
3. Attach the positive terminal of the power supply (3V - 6V) to VIN.
4. Attach the negative terminal of the power supply to GND pin.
5. Turn on power supply.
6. SW1 works with SW3 to set flash mode.
  - a. Press SW1 once to trigger the flash sequencing. First, the microcontroller will enable charge for certain time and then trigger the IGBT to light up the flash tube
  - b. Switch SW3 Bit0 to “1” to turn on flash mode
  - c. Switch SW3 Bit1 to “1” will set the charge time to be about 12.8S +3.2S (if Bit2 is set to “1”) before flash
  - d. Switch SW3 Bit2 to “1” will set the charge time to be about 3.2S +12.8S (if Bit1 is set to “1”) before flash
  - e. Switch SW3 Bit3 to “1” will set “red eye reduction” mode. The flash will be triggered for a few small pulses after the Co is charged up, and Co will be completely discharged by following flash.
7. SW2 serves as a toggle SW to start/stop the charge, no flash will be triggered.

**NOTICE:** The information in this document is subject to change without notice. Users should warrant and guarantee that third party Intellectual Property rights are not infringed upon when integrating MPS products into any application. MPS will not assume any legal responsibility for any said applications.