

isc N-Channel MOSFET Transistor

18N50

• DESCRIPTION

- Drain Current $I_D = 18A @ T_C = 25^\circ C$
- Drain Source Voltage
: $V_{DSS} = 500V (Min)$
- Static Drain-Source On-Resistance
: $R_{DS(on)} = 0.32 \Omega (Max)$
- Fast Switching

• APPLICATIONS

- Switch regulators
- Switching converters, motor drivers, relay drivers

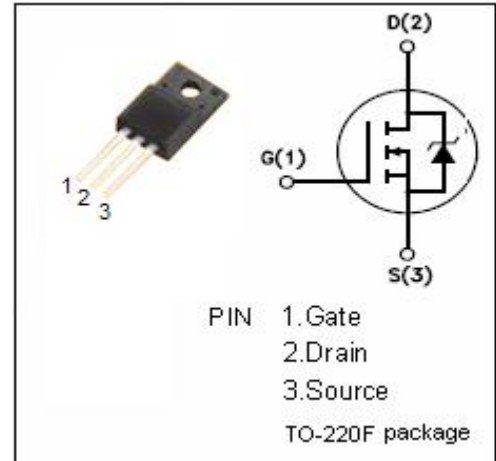

• ABSOLUTE MAXIMUM RATINGS($T_a = 25^\circ C$)

SYMBOL	PARAMETER	VALUE	UNIT
V_{DSS}	Drain-Source Voltage	500	V
V_{GS}	Gate-Source Voltage-Continuous	± 20	V
I_D	Drain Current-Continuous	18	A
I_{DM}	Drain Current-Single Plused	72	A
P_D	Total Dissipation @ $T_C = 25^\circ C$	38.5	W
T_j	Max. Operating Junction Temperature	150	$^\circ C$
T_{stg}	Storage Temperature	-55~150	$^\circ C$

• THERMAL CHARACTERISTICS

SYMBOL	PARAMETER	MAX	UNIT
$R_{th j-c}$	Thermal Resistance, Junction to Case	3.3	$^\circ C/W$
$R_{th j-a}$	Thermal Resistance, Junction to Ambient	62.5	$^\circ C/W$

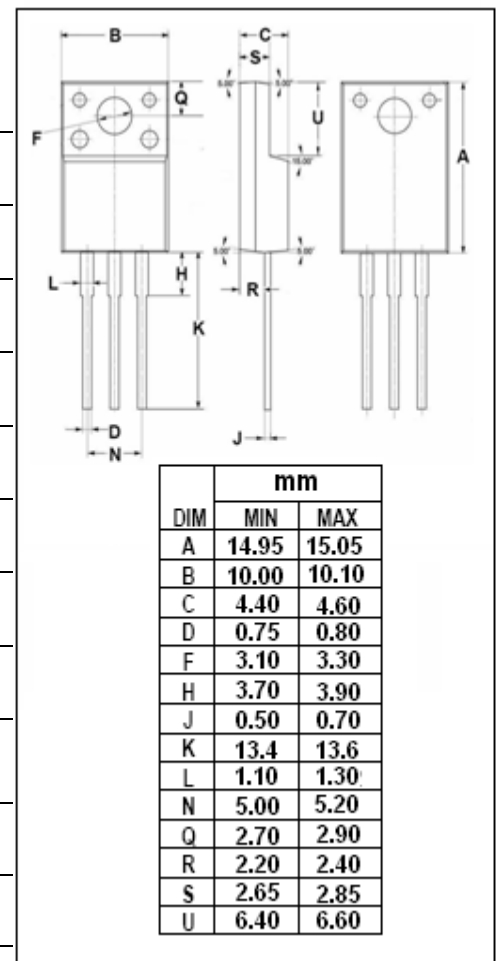

isc N-Channel MOSFET Transistor

18N50

• ELECTRICAL CHARACTERISTICS

 $T_C=25^{\circ}\text{C}$ unless otherwise specified

SYMBOL	PARAMETER	CONDITIONS	MIN	TYPE	MAX	UNIT
$V_{(BR)DSS}$	Drain-Source Breakdown Voltage	$V_{GS}=0; I_D=250\mu\text{A}$	500			V
$V_{GS(th)}$	Gate Threshold Voltage	$V_{DS}=V_{GS}; I_D=250\mu\text{A}$	2.0		4.0	V
V_{SD}	Diode Forward On-voltage	$I_S=18\text{A}; V_{GS}=0$			1.4	V
$R_{DS(on)}$	Drain-Source On-Resistance	$V_{GS}=10\text{V}; I_D=9\text{A}$			0.1	Ω
I_{GSS}	Gate-Body Leakage Current	$V_{GS}=\pm 20\text{V}; V_{DS}=0$			± 100	nA
I_{DSS}	Zero Gate Voltage Drain Current	$V_{DS}=500\text{V}; V_{GS}=0$			1	μA
C_{iss}	Input Capacitance	$V_{DS}=25\text{V};$			2860	pF
C_{rss}	Reverse Transfer capacitance	$V_{GS}=0\text{V};$			40	
C_{oss}	Output Capacitance	$f_T=1\text{MHz}$			430	
t_r	Rise Time	$V_{GS}=10\text{V};$			340	ns
$t_{d(on)}$	Turn-on Delay Time	$I_D=18\text{A};$			120	
t_f	Fall Time	$V_{DD}=250\text{V};$			190	
$t_{d(off)}$	Turn-off Delay Time	$R_L=25\Omega$			200	