

Description:

This P-Channel MOSFET uses advanced trench technology and design to provide excellent $R_{DS(on)}$ with low gate charge. It can be used in a wide variety of applications.

Features:

- 1) $V_{DS}=-30V, I_D=-5.1A, R_{DS(ON)}<55m\ \Omega @V_{GS}=-10V$
- 2) Low gate charge.
- 3) Green device available.
- 4) Advanced high cell density trench technology for ultra $R_{DS(ON)}$.
- 5) Excellent package for good heat dissipation.

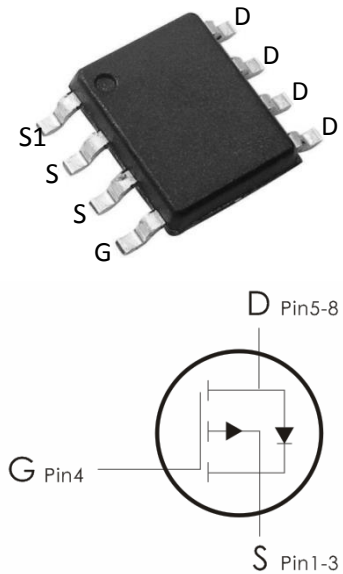

Absolute Maximum Ratings: ($T_C=25^\circ C$ unless otherwise noted)

Symbol	Parameter	Ratings	Units
V_{DS}	Drain-Source Voltage	-30	V
V_{GS}	Gate-Source Voltage	± 20	V
I_D	Continuous Drain Current- $T_C=25^\circ C$	-5.1	A
	Continuous Drain Current- $T_C=100^\circ C$	---	
	Pulsed Drain Current ¹	-20	
P_D	Power Dissipation ⁴	2.5	W
T_J, T_{STG}	Operating and Storage Junction Temperature Range	-55 to +150	$^\circ C$

Thermal Characteristics:

Symbol	Parameter	Max	Units
$R_{\theta JA}$	Thermal Resistance, Junction to Ambient ²	50	

Electrical Characteristics: ($T_C=25^{\circ}\text{C}$ unless otherwise noted)

Symbol	Parameter	Conditions	Min	Typ	Max	Units
Off Characteristics						
BV_{DSS}	Drain-Source Breakdown Voltage	$V_{GS}=0V, I_D=250\ \mu\text{A}$	-30	-33	---	V
I_{DSS}	Zero Gate Voltage Drain Current	$V_{GS}=0V, V_{DS}=-24V$	---	---	-1	μA
I_{GSS}	Gate-Source Leakage Current	$V_{GS}=\pm 20V, V_{DS}=0A$	---	---	± 100	nA
On Characteristics³						
$V_{GS(th)}$	GATE-Source Threshold Voltage	$V_{GS}=V_{DS}, I_D=250\ \mu\text{A}$	-1	-1.6	-3	V
$R_{DS(on)}$	Drain-Source On Resistance ²	$V_{GS}=-10V, I_D=-5.1A$	---	43	55	m Ω
		$V_{GS}=-4.5V, I_D=-4.2A$	---	62	90	
G_{FS}	Forward Transconductance	$V_{DS}=-15V, I_D=-5.1A$	4	7	---	S
Dynamic Characteristics⁴						
C_{iss}	Input Capacitance	$V_{DS}=-15V, V_{GS}=0V, f=1\text{MHz}$	---	980	---	pF
C_{oss}	Output Capacitance		---	390	---	
C_{rss}	Reverse Transfer Capacitance		---	135	---	
Switching Characteristics⁴						
$t_{d(on)}$	Turn-On Delay Time	$V_{DD}=-15V, I_D=-1A,$ $R_{GEN}=6\ \Omega$	---	14	---	ns
t_r	Rise Time		---	12	---	ns
$t_{d(off)}$	Turn-Off Delay Time		---	56	---	ns
t_f	Fall Time		---	20	---	ns
Q_g	Total Gate Charge	$V_{GS}=-10V, V_{DS}=-15V,$ $I_D=-5.1A$	---	11	---	nC
Q_{gs}	Gate-Source Charge		---	2	---	nC
Q_{gd}	Gate-Drain "Miller" Charge		---	2.8	---	nC
Drain-Source Diode Characteristics						
V_{SD}	Source-Drain Diode Forward Voltage ³	$V_{GS}=0V, I_S=-5.1A$	---	---	-1.2	V

Notes:

1. Repetitive Rating: Pulse width limited by maximum junction temperature.
2. Surface Mounted on FR4 Board, $t \leq 10$ sec.
3. Pulse Test: Pulse Width $\leq 300\mu\text{s}$, Duty Cycle $\leq 2\%$.
4. Guaranteed by design, not subject to production.

Typical Characteristics: ($T_c=25^\circ\text{C}$ unless otherwise noted)

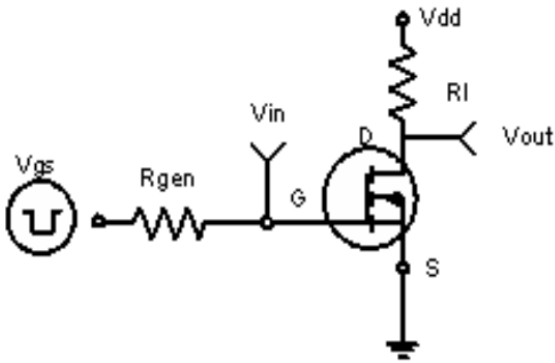

Figure 1: Switching Test Circuit

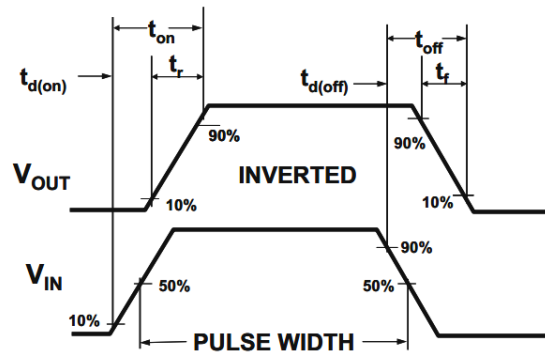

Figure 2: Switching Waveforms

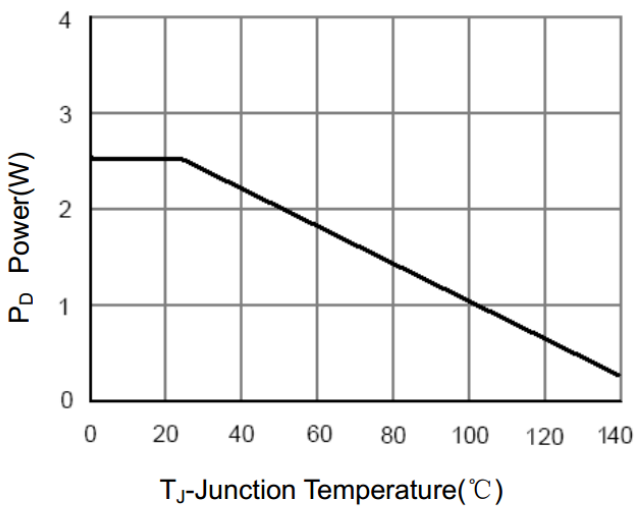

Figure 3 Power Dissipation

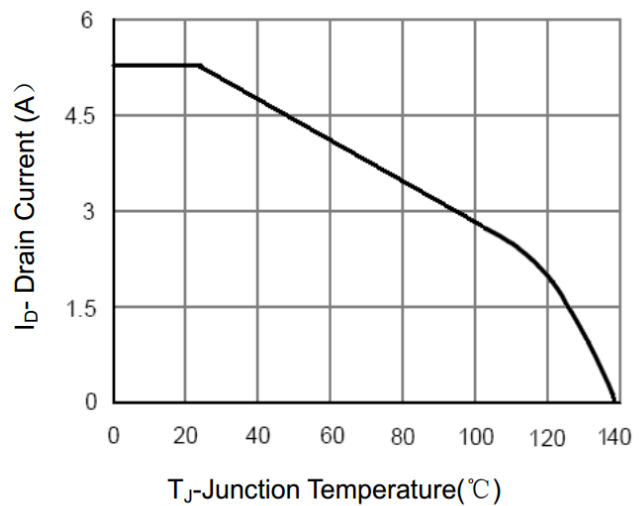

Figure 4 Drain Current

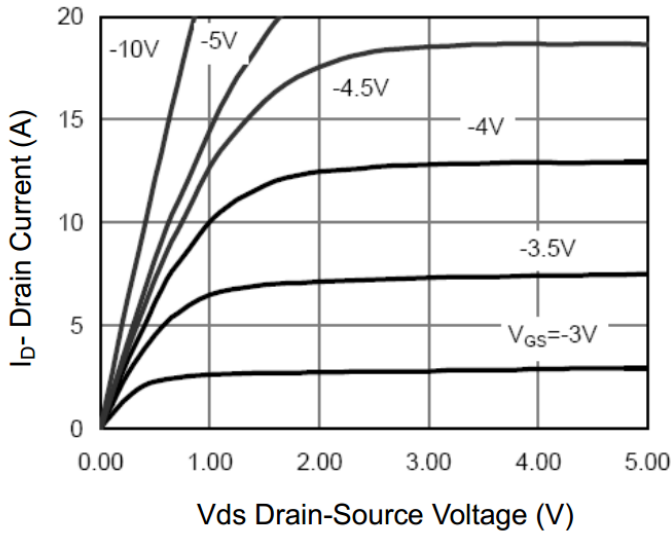

Figure 5 Output Characteristics

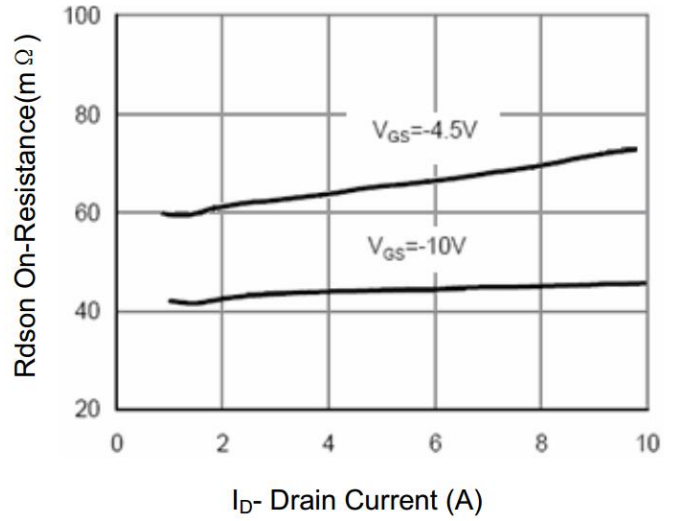

Figure 6 Drain-Source On-Resistance

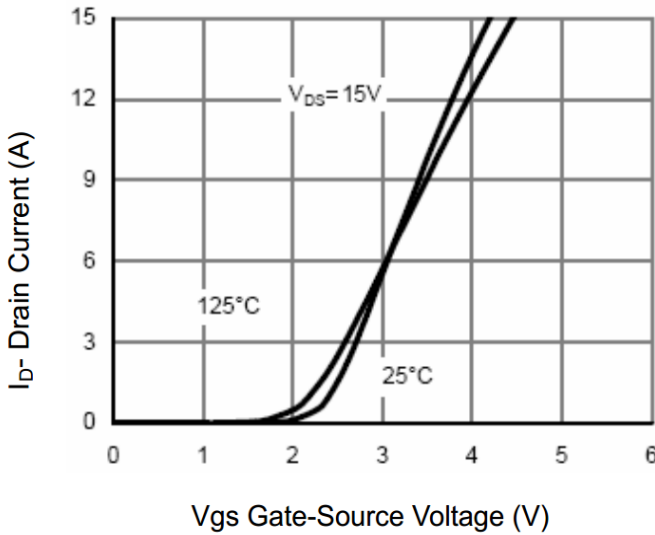

Figure 7 Transfer Characteristics

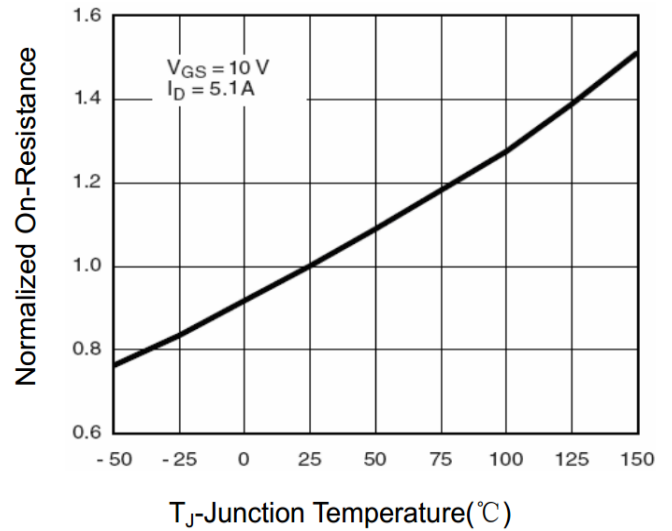

Figure 8 Drain-Source On-Resistance

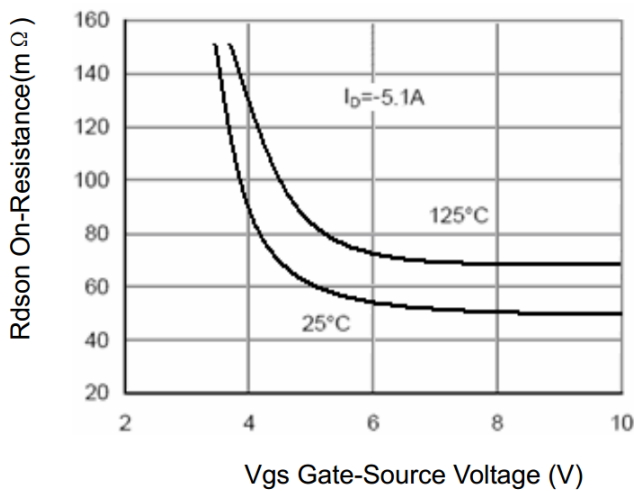

Figure 9 Rds(on) vs Vgs

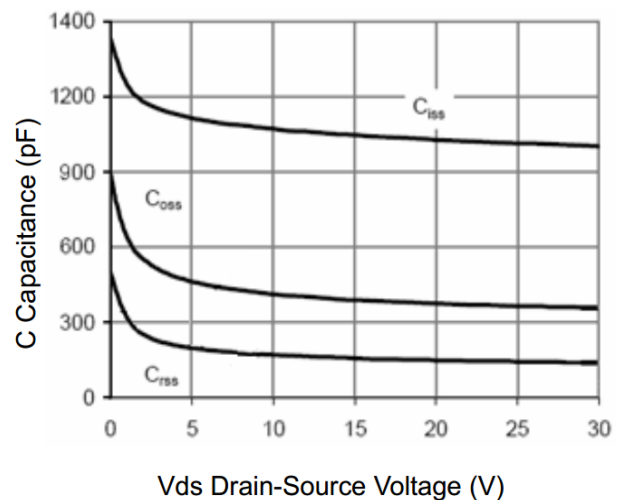
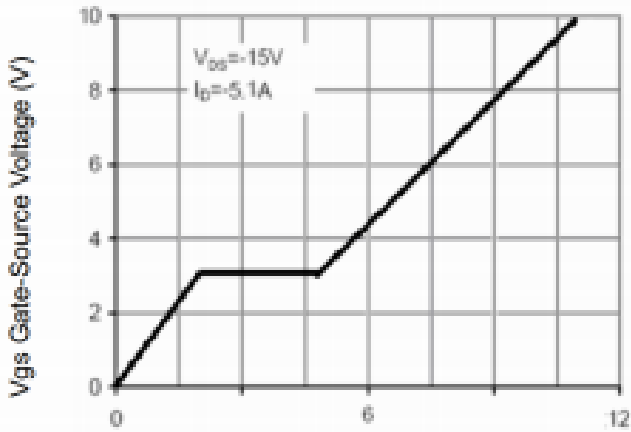
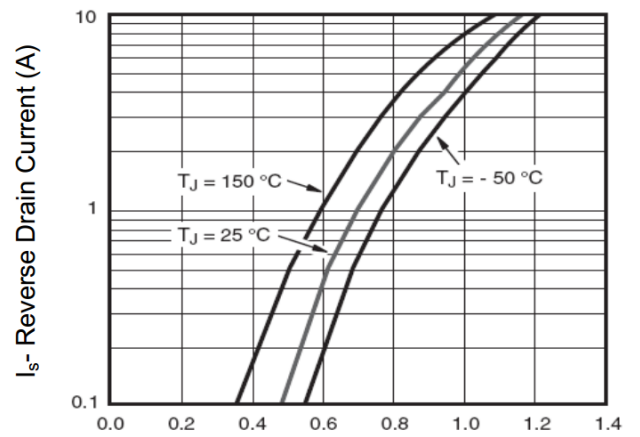

Figure 10 Capacitance vs Vds



Qg Gate Charge (nC)
Figure 11 Gate Charge



Vsd Source-Drain Voltage (V)
Figure 12 Source- Drain Diode Forward

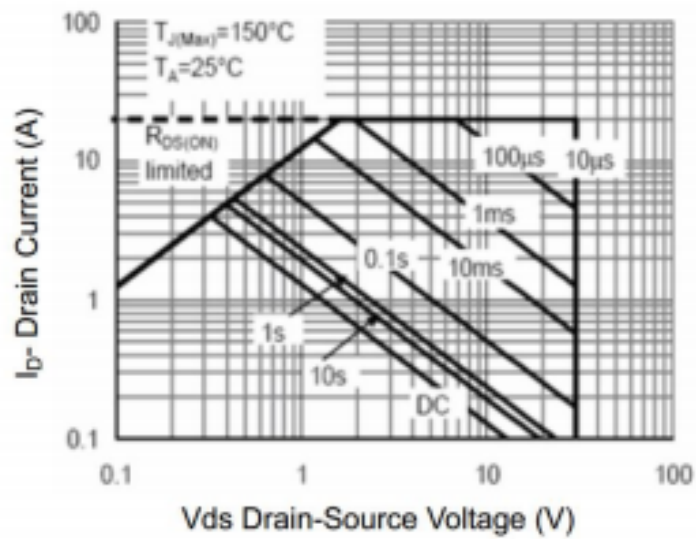

Vds Drain-Source Voltage (V)
Figure 13 Safe Operation Area

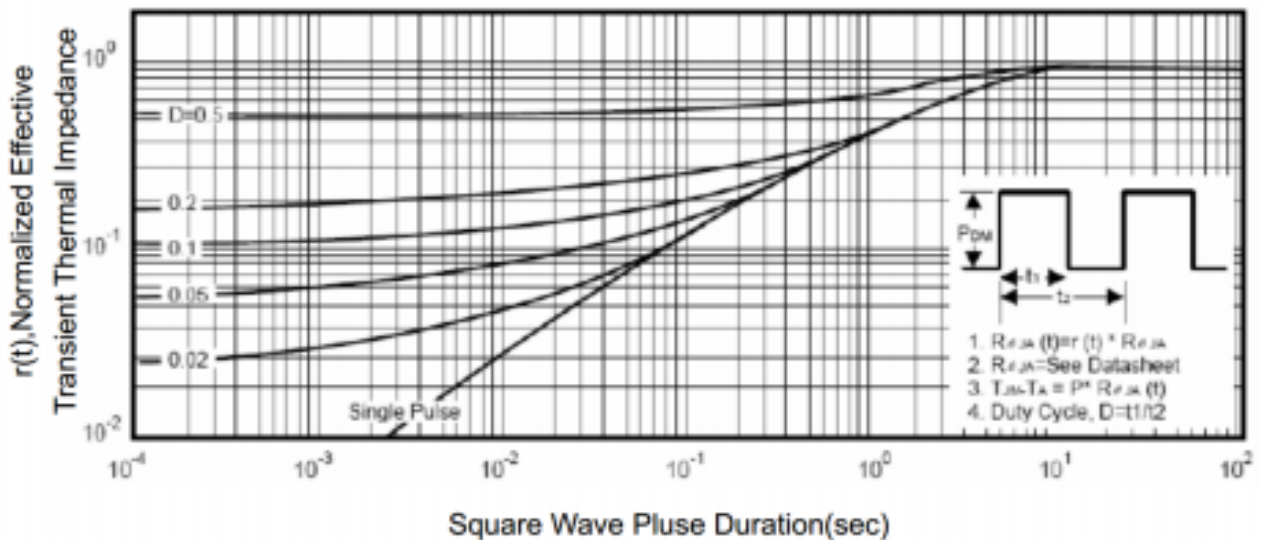

Square Wave Pulse Duration(sec)
Figure 14 Normalized Maximum Transient Thermal Impedance

