

To all our customers

---

## **Regarding the change of names mentioned in the document, such as Mitsubishi Electric and Mitsubishi XX, to Renesas Technology Corp.**

---

The semiconductor operations of Hitachi and Mitsubishi Electric were transferred to Renesas Technology Corporation on April 1st 2003. These operations include microcomputer, logic, analog and discrete devices, and memory chips other than DRAMs (flash memory, SRAMs etc.) Accordingly, although Mitsubishi Electric, Mitsubishi Electric Corporation, Mitsubishi Semiconductors, and other Mitsubishi brand names are mentioned in the document, these names have in fact all been changed to Renesas Technology Corp. Thank you for your understanding. Except for our corporate trademark, logo and corporate statement, no changes whatsoever have been made to the contents of the document, and these changes do not constitute any alteration to the contents of the document itself.

Note : Mitsubishi Electric will continue the business operations of high frequency & optical devices and power devices.

Renesas Technology Corp.  
Customer Support Dept.  
April 1, 2003

MITSUBISHI 8-BIT SINGLE-CHIP MICROCOMPUTER  
740 FAMILY / 38000 SERIES

3806  
Group

User's Manual

Keep safety first in your circuit designs!

- Mitsubishi Electric Corporation puts the maximum effort into making semiconductor products better and more reliable, but there is always the possibility that trouble may occur with them. Trouble with semiconductors may lead to personal injury, fire or property damage. Remember to give due consideration to safety when making your circuit designs, with appropriate measures such as (i) placement of substitutive, auxiliary circuits, (ii) use of non-flammable material or (iii) prevention against any malfunction or mishap.

Notes regarding these materials

- These materials are intended as a reference to assist our customers in the selection of the Mitsubishi semiconductor product best suited to the customer's application; they do not convey any license under any intellectual property rights, or any other rights, belonging to Mitsubishi Electric Corporation or a third party.
- Mitsubishi Electric Corporation assumes no responsibility for any damage, or infringement of any third-party's rights, originating in the use of any product data, diagrams, charts or circuit application examples contained in these materials.
- All information contained in these materials, including product data, diagrams and charts, represent information on products at the time of publication of these materials, and are subject to change by Mitsubishi Electric Corporation without notice due to product improvements or other reasons. It is therefore recommended that customers contact Mitsubishi Electric Corporation or an authorized Mitsubishi Semiconductor product distributor for the latest product information before purchasing a product listed herein.
- Mitsubishi Electric Corporation semiconductors are not designed or manufactured for use in a device or system that is used under circumstances in which human life is potentially at stake. Please contact Mitsubishi Electric Corporation or an authorized Mitsubishi Semiconductor product distributor when considering the use of a product contained herein for any specific purposes, such as apparatus or systems for transportation, vehicular, medical, aerospace, nuclear, or undersea repeater use.
- The prior written approval of Mitsubishi Electric Corporation is necessary to reprint or reproduce in whole or in part these materials.
- If these products or technologies are subject to the Japanese export control restrictions, they must be exported under a license from the Japanese government and cannot be imported into a country other than the approved destination.  
Any diversion or reexport contrary to the export control laws and regulations of Japan and/or the country of destination is prohibited.
- Please contact Mitsubishi Electric Corporation or an authorized Mitsubishi Semiconductor product distributor for further details on these materials or the products contained therein.

## Preface

This user's manual describes Mitsubishi's CMOS 8-bit microcomputers 3806 Group.

After reading this manual, the user should have a thorough knowledge of the functions and features of the 3806 Group, and should be able to fully utilize the product. The manual starts with specifications and ends with application examples.

For details of software, refer to the "SERIES MELPS 740 <SOFTWARE> USER'S MANUAL."

For details of development support tools, refer to the "DEVELOPMENT SUPPORT TOOLS FOR MICRO-COMPUTERS" data book.

# BEFORE USING THIS USER'S MANUAL

This user's manual consists of the following three chapters. Refer to the chapter appropriate to your conditions, such as hardware design or software development. Chapter 3 also includes necessary information for systems development. Be sure to refer to this chapter.

## 1. Organization

### ● CHAPTER 1 HARDWARE

This chapter describes features of the microcomputer and operation of each peripheral function.

### ● CHAPTER 2 APPLICATION

This chapter describes usage and application examples of peripheral functions, based mainly on setting examples of related registers.

### ● CHAPTER 3 APPENDIX

This chapter includes necessary information for systems development using the microcomputer, electric characteristics, a list of registers, the masking confirmation (mask ROM version), and mark specifications which are to be submitted when ordering.

## 2. Structure of register

The figure of each register structure describes its functions, contents at reset, and attributes as follows :

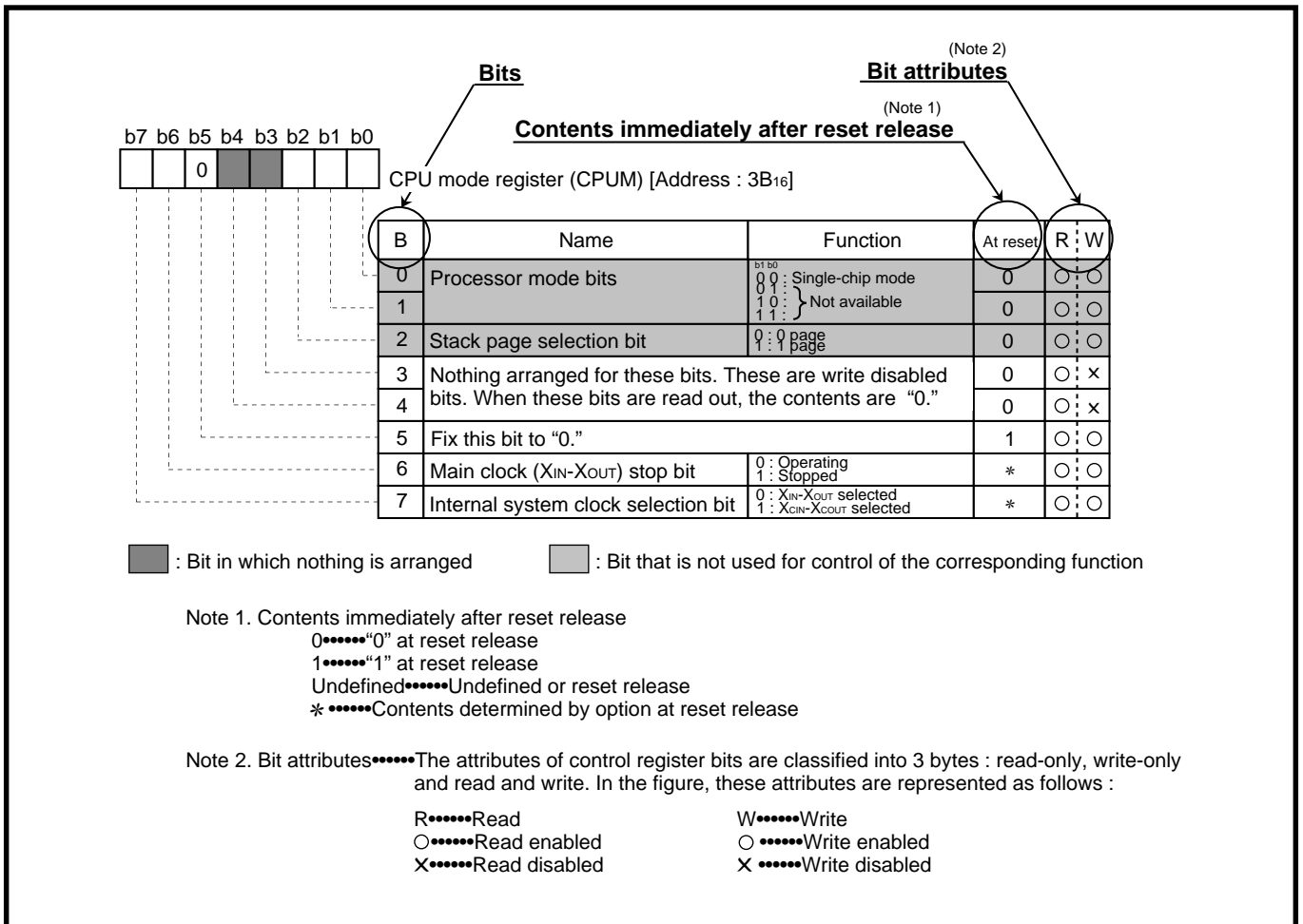

## LIST OF GROUPS HAVING THE SIMILAR FUNCTIONS

3806 group, one of the CMOS 8-bit microcomputer 38000 series presented in this user's manual is provided with standard functions.

The basic functions of the 3800, 3802, 3806 and 3807 groups having the same functions are shown below. For the detailed functions of each group, refer to the related data book and user's manual.

### List of groups having the same functions

As of September 1995

Group		3800 group					3802 group				3806 group					3807 group
Function	Group															
Pin (Package type)		64 pin • 64P4B • 64P6N-A • 64P6D-A					64 pin • 64P4B • 64P6N-A				80 pin • 80P6N-A • 80P6S-A • 80P6D-A					80 pin • 80P6N-A
Clock generating circuit		1 circuit					1 circuit				1 circuit					2 circuits
Timer		<8-bit> Prescaler : 3 Timer : 4					<8-bit> Prescaler : 3 Timer : 4				<8-bit> Prescaler : 3 Timer : 4					<8-bit> Timer : 3 <16-bit> Timer X/Y : 2 Timer A/B : 2
Serial I/O		UART or Clock synchronous X 1					UART or Clock synchronous X 1				UART or Clock synchronous X 1					UART or Clock synchronous X 1
		—					Clock synchronous X 1				Clock synchronous X 1					Clock synchronous X 1
A-D converter		—					8-bit X 8-channel				8-bit X 8-channel					8-bit X 13-channel
D-A converter		—					8-bit X 2-channel				8-bit X 2-channel					8-bit X 4-channel
Memory type	Mask ROM	8K <small>(Note 1)</small>	16K <small>(Note 1)</small>	24K	32K <small>(Note 1)</small>	*	8K <small>(Note 1)</small>	16K <small>(Note 1)</small>	24K	32K <small>(Note 1)</small>	12K <small>(Note 1)</small>	16K <small>(Note 1)</small>	24K <small>(Note 3)</small>	32K <small>(Note 3)</small>	48K <small>(Note 3)</small>	16K
	One Time PROM	8K <small>(Note 1)</small>	16K <small>(Note 1)</small>	—	32K	—	—	—	—	32K <small>(Note 1)</small>	—	—	24K <small>(Note 2)</small>	—	48K <small>(Note 3)</small>	16K
	EPROM	—	16K	—	32K	—	—	—	—	32K	—	—	24K	—	48K <small>(Note 2)</small>	16K
	RAM	384	384	512	640	384	384	384	640	1024	384	384	512	1024	1024	512
Remarks							PWM output									Real time port output Analog comparator Watchdog timer

**Notes 1:** Extended operating temperature version available

**2:** High-speed version available

**3:** Extended operating temperature version and High-speed version available

\*. ROM expansion

# Table of contents

## CHAPTER 1. HARDWARE

<b>DESCRIPTION</b> .....	<b>1-2</b>
<b>FEATURES</b> .....	<b>1-2</b>
<b>APPLICATIONS</b> .....	<b>1-2</b>
<b>PIN CONFIGURATION</b> .....	<b>1-2</b>
<b>FUNCTIONAL BLOCK</b> .....	<b>1-4</b>
<b>PIN DESCRIPTION</b> .....	<b>1-5</b>
<b>PART NUMBERING</b> .....	<b>1-7</b>
<b>GROUP EXPANSION</b> .....	<b>1-8</b>
<b>GROUP EXPANSION (EXTENDED OPERATING TEMPERATURE VERSION)</b> .....	<b>1-10</b>
<b>GROUP EXPANSION (HIGH-SPEED VERSION)</b> .....	<b>1-11</b>
<b>FUNCTIONAL DESCRIPTION</b> .....	<b>1-12</b>
Central Processing Unit (CPU) .....	1-12
Memory .....	1-16
I/O Ports .....	1-18
Interrupts .....	1-21
Timers .....	1-23
Serial I/O .....	1-25
A-D Converter .....	1-31
D-A Converter .....	1-32
Reset Circuit .....	1-31
Clock Generating Circuit .....	1-35
Processor Modes .....	1-36
<b>NOTES ON PROGRAMMING</b> .....	<b>1-38</b>
Processor Status Register .....	1-38
Interrupts .....	1-38
Decimal Calculations .....	1-38
Timers .....	1-38
Multiplication and Division Instructions .....	1-38
Ports .....	1-38
Serial I/O .....	1-38
A-D Converter .....	1-38
D-A Converter .....	1-38
Instruction Execution Time .....	1-38
Memory Expansion Mode and Microprocessor Mode .....	1-38
<b>DATA REQUIRED FOR MASK ORDERS</b> .....	<b>1-39</b>

## Table of contents

---

<b>ROM PROGRAMMING METHOD .....</b>	<b>1-39</b>
<b>FUNCTIONAL DESCRIPTION SUPPLEMENT .....</b>	<b>1-40</b>
Interrupt .....	1-40
Timing After Interrupt.....	1-41
A-D Converter .....	1-42

## CHAPTER 2. APPLICATION

---

<b>2.1 I/O port .....</b>	<b>2-2</b>
2.1.1 Memory map of I/O port .....	2-2
2.1.2 Related registers .....	2-3
2.1.3 Handling of unused pins .....	2-4
<b>2.2 Timer .....</b>	<b>2-5</b>
2.2.1 Memory map of timer .....	2-5
2.2.2 Related registers .....	2-6
2.2.3 Timer application examples .....	2-11
<b>2.3 Serial I/O .....</b>	<b>2-23</b>
2.3.1 Memory map of serial I/O .....	2-23
2.3.2 Related registers .....	2-24
2.3.3 Serial I/O connection examples .....	2-30
2.3.4 Setting of serial I/O transfer data format .....	2-32
2.3.5 Serial I/O application examples .....	2-33
<b>2.4 A-D converter .....</b>	<b>2-53</b>
2.4.1 Memory map of A-D conversion .....	2-53
2.4.2 Related registers .....	2-54
2.4.3 A-D conversion application example .....	2-56
<b>2.5 Processor mode .....</b>	<b>2-58</b>
2.5.1 Memory map of processor mode .....	2-58
2.5.2 Related register .....	2-58
2.5.3 Processor mode application examples .....	2-59
<b>2.6 Reset .....</b>	<b>2-66</b>
2.6.1 Connection example of reset IC .....	2-66

## CHAPTER 3. APPENDIX

---

<b>3.1 Electrical characteristics .....</b>	<b>3-2</b>
3.1.1 Absolute maximum ratings .....	3-2
3.1.2 Recommended operating conditions .....	3-3
3.1.3 Electrical characteristics .....	3-4
3.1.4 A-D converter characteristics .....	3-4
3.1.5 D-A converter characteristics .....	3-5
3.1.6 Timing requirements and Switching characteristics .....	3-6
3.1.7 Absolute maximum ratings (Extended operating temperature version) .....	3-10
3.1.8 Recommended operating conditions(Extended operating temperature version) ..	3-10



3.1.9 Electrical characteristics (Extended operating temperature version) .....	3-11
3.1.10 A-D converter characteristics (Extended operating temperature version) .....	3-11
3.1.11 D-A converter characteristics (Extended operating temperature version) .....	3-12
3.1.12 Timing requirements and Switching characteristics (Extended operating temperature version).....	3-13
3.1.13 Absolute maximum ratings (High-speed version) .....	3-15
3.1.14 Recommended operating conditions(High-speed version).....	3-15
3.1.15 Electrical characteristics (High-speed version) .....	3-16
3.1.16 A-D converter characteristics (High-speed version) .....	3-16
3.1.17 D-A converter characteristics (High-speed version) .....	3-17
3.1.18 Timing requirements and Switching characteristics (High-speed version).....	3-18
3.1.19 Timing diagram .....	3-22
<b>3.2 Standard characteristics .....</b>	<b>3-25</b>
3.2.1 Power source current characteristic examples .....	3-25
3.2.2 Port standard characteristic examples .....	3-26
3.2.3 A-D conversion standard characteristics.....	3-28
3.2.4 D-A conversion standard characteristics.....	3-29
<b>3.3 Notes on use .....</b>	<b>3-30</b>
3.3.1 Notes on interrupts .....	3-30
3.3.2 Notes on the serial I/O1 .....	3-30
3.3.3 Notes on the A-D converter .....	3-31
3.3.4 Notes on the RESET pin .....	3-32
3.3.5 Notes on input and output pins .....	3-32
3.3.6 Notes on memory expansion mode and microprocessor mode .....	3-33
3.3.7 Notes on built-in PROM .....	3-34
<b>3.4 Countermeasures against noise .....</b>	<b>3-36</b>
3.4.1 Shortest wiring length.....	3-36
3.4.2 Connection of a bypass capacitor across the Vss line and the Vcc line.....	3-37
3.4.3 Wiring to analog input pins .....	3-38
3.4.4 Consideration for oscillator .....	3-38
3.4.5 Setup for I/O ports.....	3-39
3.4.6 Providing of watchdog timer function by software .....	3-39
<b>3.5 List of registers .....</b>	<b>3-41</b>
<b>3.6 Mask ROM ordering method .....</b>	<b>3-53</b>
<b>3.7 Mark specification form .....</b>	<b>3-79</b>
<b>3.8 Package outline .....</b>	<b>3-81</b>
<b>3.9 List of instruction codes .....</b>	<b>3-83</b>
<b>3.10 Machine Instructions .....</b>	<b>3-84</b>
<b>3.11 SFR memory map .....</b>	<b>3-94</b>
<b>3.12 Pin configuration .....</b>	<b>3-95</b>

# List of figures

## CHAPTER 1 HARDWARE

Fig. 1 Pin configuration of M38063M6-XXXFP .....	1-2
Fig. 2 Pin configuration of M38063M6-XXXGP and M38063M6AXXXHP .....	1-3
Fig. 3 Functional block diagram .....	1-4
Fig. 4 Part numbering .....	1-7
Fig. 5 Memory expansion plan .....	1-8
Fig. 6 Memory expansion plan (Extended operating temperature version) .....	1-10
Fig. 7 Memory expansion plan (High-speed version) .....	1-11
Fig. 8 740 Family CPU register structure .....	1-12
Fig. 9 Register push and pop at interrupt generation and subroutine call .....	1-13
Fig. 10 Structure of CPU mode register .....	1-15
Fig. 11 Memory map diagram .....	1-16
Fig. 12 Memory map of special function register (SFR) .....	1-17
Fig. 13 Port block diagram (single-chip mode) (1) .....	1-19
Fig. 14 Port block diagram (single-chip mode) (2) .....	1-20
Fig. 15 Interrupt control .....	1-22
Fig. 16 Structure of interrupt-related registers .....	1-22
Fig. 17 Structure of timer XY register .....	1-23
Fig. 18 Block diagram of timer X, timer Y, timer 1, and timer 2 .....	1-24
Fig. 19 Block diagram of clock synchronous serial I/O1 .....	1-25
Fig. 20 Operation of clock synchronous serial I/O1 function .....	1-25
Fig. 21 Block diagram of UART serial I/O .....	1-26
Fig. 22 Operation of UART serial I/O function .....	1-27
Fig. 23 Structure of serial I/O control registers .....	1-28
Fig. 24 Structure of serial I/O2 control register .....	1-29
Fig. 25 Block diagram of serial I/O2 function .....	1-29
Fig. 26 Timing of serial I/O2 function .....	1-30
Fig. 27 Structure of AD/DA control register .....	1-31
Fig. 28 Block diagram of A-D converter .....	1-31
Fig. 29 Block diagram of D-A converter .....	1-32
Fig. 30 Equivalent connection circuit of D-A converter .....	1-32
Fig. 31 Example of reset circuit .....	1-33
Fig. 32 Internal status of microcomputer after reset .....	1-33
Fig. 33 Timing of reset .....	1-34
Fig. 34 Ceramic resonator circuit .....	1-35
Fig. 35 External clock input circuit .....	1-35
Fig. 36 Block diagram of clock generating circuit .....	1-35
Fig. 37 Memory maps in various processor modes .....	1-36
Fig. 38 Structure of CPU mode register .....	1-36
Fig. 39 ONW function timing .....	1-37
Fig. 40 Programming and testing of One Time PROM version .....	1-39
Fig. 41 Timing chart after an interrupt occurs .....	1-41
Fig. 42 Time up to execution of the interrupt processing routine .....	1-41
Fig. 43 A-D conversion equivalent circuit .....	1-43
Fig. 44 A-D conversion timing chart .....	1-43

## List of figures

---

### CHAPTER 2 APPLICATION

---

Fig. 2.1.1 Memory map of I/O port related registers .....	2-2
Fig. 2.1.2 Structure of Port Pi (i=0, 1, 2, 3, 4, 5, 6, 7, 8) .....	2-3
Fig. 2.1.3 Structure of Port Pi direction register (i=0, 1, 2, 3, 4, 5, 6, 7, 8) .....	2-3
Fig. 2.2.1 Memory map of timer related registers .....	2-5
Fig. 2.2.2 Structure of Prescaler 12, Prescaler X, Prescaler Y .....	2-6
Fig. 2.2.3 Structure of Timer 1 .....	2-6
Fig. 2.2.4 Structure of Timer 2, Timer X, Timer Y .....	2-7
Fig. 2.2.5 Structure of Timer XY mode register .....	2-8
Fig. 2.2.6 Structure of Interrupt request register 1 .....	2-9
Fig. 2.2.7 Structure of Interrupt request register 2 .....	2-9
Fig. 2.2.8 Structure of Interrupt control register 1 .....	2-10
Fig. 2.2.9 Structure of Interrupt control register 2 .....	2-10
Fig. 2.2.10 Connection of timers and setting of division ratios [Clock function] .....	2-12
Fig. 2.2.11 Setting of related registers [Clock function] .....	2-13
Fig. 2.2.12 Control procedure [Clock function] .....	2-14
Fig. 2.2.13 Example of a peripheral circuit .....	2-15
Fig. 2.2.14 Connection of the timer and setting of the division ratio [Piezoelectric buzzer output] .....	2-15
Fig. 2.2.15 Setting of related registers [Piezoelectric buzzer output] .....	2-16
Fig. 2.2.16 Control procedure [Piezoelectric buzzer output] .....	2-16
Fig. 2.2.17 A method for judging if input pulse exists .....	2-17
Fig. 2.2.18 Setting of related registers [Measurement of frequency] .....	2-18
Fig. 2.2.19 Control procedure [Measurement of frequency] .....	2-19
Fig. 2.2.20 Connection of the timer and setting of the division ratio [Measurement of pulse width] .....	2-20
Fig. 2.2.21 Setting of related registers [Measurement of pulse width] .....	2-21
Fig. 2.2.22 Control procedure [Measurement of pulse width] .....	2-22
Fig. 2.3.1 Memory map of serial I/O related registers .....	2-23
Fig. 2.3.2 Structure of Transmit/Receive buffer register .....	2-24
Fig. 2.3.3 Structure of Serial I/O1 status register .....	2-24
Fig. 2.3.4 Structure of Serial I/O1 control register .....	2-25
Fig. 2.3.5 Structure of UART control register .....	2-25
Fig. 2.3.6 Structure of Baud rate generator .....	2-26
Fig. 2.3.7 Structure of Serial I/O2 control register .....	2-26
Fig. 2.3.8 Structure of Serial I/O2 register .....	2-27
Fig. 2.3.9 Structure of Interrupt edge selection register .....	2-27
Fig. 2.3.10 Structure of Interrupt request register 1 .....	2-28
Fig. 2.3.11 Structure of Interrupt request register 2 .....	2-28
Fig. 2.3.12 Structure of Interrupt control register 1 .....	2-29
Fig. 2.3.13 Structure of Interrupt control register 2 .....	2-29
Fig. 2.3.14 Serial I/O connection examples (1) .....	2-30
Fig. 2.3.15 Serial I/O connection examples (2) .....	2-31
Fig. 2.3.16 Setting of Serial I/O transfer data format .....	2-32
Fig. 2.3.17 Connection diagram [Communication using a clock synchronous serial I/O] ..	2-33
Fig. 2.3.18 Timing chart [Communication using a clock synchronous serial I/O] .....	2-33
Fig. 2.3.19 Setting of related registers at a transmitting side [Communication using a clock synchronous serial I/O] .....	2-34
Fig. 2.3.20 Setting of related registers at a receiving side [Communication using a clock synchronous serial I/O] .....	2-35

Fig. 2.3.21 Control procedure at a transmitting side [Communication using a clock synchronous serial I/O] .....	2-36
Fig. 2.3.22 Control procedure at a receiving side[Communication using a clock synchronous serial I/O] .	2-37
Fig. 2.3.23 Connection diagram [Output of serial data] .....	2-38
Fig. 2.3.24 Timing chart [Output of serial data] .....	2-38
Fig. 2.3.25 Setting of serial I/O1 related registers [Output of serial data].....	2-39
Fig. 2.3.26 Setting of serial I/O1 transmission data [Output of serial data] .....	2-39
Fig. 2.3.27 Control procedure of serial I/O1 [Output of serial data] .....	2-40
Fig. 2.3.28 Setting of serial I/O2 related registers [Output of serial data].....	2-41
Fig. 2.3.29 Setting of serial I/O2 transmission data [Output of serial data] .....	2-41
Fig. 2.3.30 Control procedure of serial I/O2 [Output of serial data] .....	2-42
Fig. 2.3.31 Connection diagram [Cyclic transmission or reception of block data between microcomputers] .	2-43
Fig. 2.3.32 Timing chart [Cyclic transmission or reception of block data between microcomputers] .....	2-44
Fig. 2.3.33 Setting of related registers [Cyclic transmission or reception of block data between microcomputers] .	2-44
Fig. 2.3.34 Control in the master unit.....	2-45
Fig. 2.3.35 Control in the slave unit .....	2-46
Fig. 2.3.36 Connection diagram [Communication using UART] .....	2-47
Fig. 2.3.37 Timing chart [Communication using UART] .....	2-47
Fig. 2.3.38 Setting of related registers at a transmitting side [Communication using UART].....	2-49
Fig. 2.3.39 Setting of related registers at a receiving side [Communication using UART] .....	2-50
Fig. 2.3.40 Control procedure at a transmitting side [Communication using UART] .....	2-51
Fig. 2.3.41 Control procedure at a receiving side [Communication using UART] .....	2-52
Fig. 2.4.1 Memory map of A-D conversion related registers .....	2-53
Fig. 2.4.2 Structure of AD/DA control register .....	2-54
Fig. 2.4.3 Structure of A-D conversion register .....	2-54
Fig. 2.4.4 Structure of Interrupt request register 2 .....	2-55
Fig. 2.4.5 Structure of Interrupt control register 2 .....	2-55
Fig. 2.4.6 Connection diagram [Conversion of Analog input voltage] .....	2-56
Fig. 2.4.7 Setting of related registers [Conversion of Analog input voltage] .....	2-56
Fig. 2.4.8 Control procedure [Conversion of Analog input voltage].....	2-57
Fig. 2.5.1 Memory map of processor mode related register .....	2-58
Fig. 2.5.2 Structure of CPU mode register .....	2-58
Fig. 2.5.3 Expansion example of ROM and RAM .....	2-59
Fig. 2.5.4 Read-cycle (OE access, SRAM) .....	2-60
Fig. 2.5.5 Read-cycle (OE access, EPROM) .....	2-60
Fig. 2.5.6 Write-cycle (W control, SRAM).....	2-61
Fig. 2.5.7 Application example of the $\overline{ONW}$ function.....	2-62
Fig. 2.5.8 Expansion example of ROM and RAM [High-speed version] .....	2-63
Fig. 2.5.9 Read-cycle (OE access, SRAM) [High-speed version] .....	2-64
Fig. 2.5.10 Read-cycle (OE access, EPROM) [High-speed version] .....	2-64
Fig. 2.5.11 Write-cycle (W control, SRAM) [High-speed version] .....	2-65
Fig. 2.6.1 Example of Poweron reset circuit .....	2-66
Fig. 2.6.2 RAM back-up system .....	2-66

## List of figures

---

### CHAPTER 3 APPENDIX

---

Fig. 3.1.1 Circuit for measuring output switching characteristics (1) .....	3-21
Fig. 3.1.2 Circuit for measuring output switching characteristics (2) .....	3-21
Fig. 3.1.3 Timing diagram (in single-chip mode) .....	3-22
Fig. 3.1.4 Timing diagram (in memory expansion mode and microprocessor mode) (1) ..	3-23
Fig. 3.1.5 Timing diagram (in memory expansion mode and microprocessor mode) (2) ..	3-24
Fig. 3.2.1 Power source current characteristic example .....	3-25
Fig. 3.2.2 Power source current characteristic example (in wait mode) .....	3-25
Fig. 3.2.3 Standard characteristic example of CMOS output port at P-channel drive(1) ..	3-26
Fig. 3.2.4 Standard characteristic example of CMOS output port at P-channel drive(2) ..	3-26
Fig. 3.2.5 Standard characteristic example of CMOS output port at N-channel drive(1) ..	3-27
Fig. 3.2.6 Standard characteristic example of CMOS output port at N-channel drive(2) ..	3-27
Fig. 3.2.7 A-D conversion standard characteristics .....	3-28
Fig. 3.2.8 D-A conversion standard characteristics .....	3-29
Fig. 3.3.1 Structure of interrupt control register 2 .....	3-30
Fig. 3.4.1 Wiring for the $\overline{\text{RESET}}$ pin .....	3-36
Fig. 3.4.2 Wiring for clock I/O pins .....	3-37
Fig. 3.4.3 Wiring for the VPP pin of the One Time PROM and the EPROM version .....	3-37
Fig. 3.4.4 Bypass capacitor across the VSS line and the VCC line .....	3-37
Fig. 3.4.5 Analog signal line and a resistor and a capacitor .....	3-38
Fig. 3.4.6 Wiring for a large current signal line .....	3-38
Fig. 3.4.7 Wiring to a signal line where potential levels change frequently .....	3-38
Fig. 3.4.8 Stepup for I/O ports .....	3-39
Fig. 3.4.9 Watchdog timer by software .....	3-39
Fig. 3.5.1 Structure of Port Pi (i=0, 1, 2, 3, 4, 5, 6, 7, 8) .....	3-41
Fig. 3.5.2 Structure of Port Pi direction register (i=0, 1, 2, 3, 4, 5, 6, 7, 8) .....	3-41
Fig. 3.5.3 Structure of Transmit/Receive buffer register .....	3-42
Fig. 3.5.4 Structure of Serial I/O1 status register .....	3-42
Fig. 3.5.5 Structure of Serial I/O1 control register .....	3-43
Fig. 3.5.6 Structure of UART control register .....	3-43
Fig. 3.5.7 Structure of Baud rate generator .....	3-44
Fig. 3.5.8 Structure of Serial I/O2 control register .....	3-44
Fig. 3.5.9 Structure of Serial I/O2 register .....	3-45
Fig. 3.5.10 Structure of Prescaler 12, Prescaler X, Prescaler Y .....	3-45
Fig. 3.5.11 Structure of Timer 1 .....	3-46
Fig. 3.5.12 Structure of Timer 2, Timer X, Timer Y .....	3-46
Fig. 3.5.13 Structure of Timer XY mode register .....	3-47
Fig. 3.5.14 Structure of AD/DA control register .....	3-48
Fig. 3.5.15 Structure of A-D conversion register .....	3-48
Fig. 3.5.16 Structure of D-A 1 conversion, D-A 2 conversion register .....	3-49
Fig. 3.5.17 Structure of Interrupt edge selection register .....	3-49
Fig. 3.5.18 Structure of CPU mode register .....	3-50
Fig. 3.5.19 Structure of Interrupt request register 1 .....	3-51
Fig. 3.5.20 Structure of Interrupt request register 2 .....	3-51
Fig. 3.5.21 Structure of Interrupt control register 1 .....	3-52
Fig. 3.5.22 Structure of Interrupt control register 2 .....	3-52

# List of tables

## CHAPTER 1 HARDWARE

Table 1 Pin description (1) .....	1-5
Table 2 Pin description (2) .....	1-6
Table 3 List of supported products .....	1-9
Table 4 List of supported products (Extended operating temperature version) .....	1-10
Table 5 List of supported products (High-speed version) .....	1-11
Table 6 Push and pop instructions of accumulator or processor status register .....	1-13
Table 7 Set and clear instructions of each bit of processor status register .....	1-14
Table 8 List of I/O port functions .....	1-18
Table 9 Interrupt vector addresses and priority .....	1-21
Table 10 Functions of ports in memory expansion mode and microprocessor mode .....	1-36
Table 11 Programming adapter .....	1-39
Table 12 Interrupt sources, vector addresses and interrupt priority .....	1-40
Table 13 Change of A-D conversion register during A-D conversion .....	1-42

## CHAPTER 2 APPLICATION

Table 2.1.1 Handling of unused pins (in single-chip mode) .....	2-4
Table 2.1.2 Handling of unused pins (in memory expansion mode and microprocessor mode) .....	2-4
Table 2.2.1 Function of CNTR0/CNTR1 edge switch bit .....	2-8
Table 2.3.1 Setting examples of Baud rate generator values and transfer bit rate values .....	2-48

## CHAPTER 3 APPENDIX

Table 3.1.1 Absolute maximum ratings .....	3-2
Table 3.1.2 Recommended operating conditions .....	3-3
Table 3.1.3 Electrical characteristics .....	3-4
Table 3.1.4 A-D converter characteristics .....	3-4
Table 3.1.5 D-A converter characteristics .....	3-5
Table 3.1.6 Timing requirements (1) .....	3-6
Table 3.1.7 Timing requirements (2) .....	3-6
Table 3.1.8 Switching characteristics (1) .....	3-7
Table 3.1.9 Switching characteristics (2) .....	3-7
Table 3.1.10 Timing requirements in memory expansion mode and microprocessor mode (1) .....	3-8
Table 3.1.11 Switching characteristics in memory expansion mode and microprocessor mode (1) .....	3-8
Table 3.1.12 Timing requirements in memory expansion mode and microprocessor mode (2) .....	3-9
Table 3.1.13 Switching characteristics in memory expansion mode and microprocessor mode (2) .....	3-9
Table 3.1.14 Absolute maximum ratings (Extended operating temperature version) .....	3-10
Table 3.1.15 Recommended operating conditions (Extended operating temperature version) .....	3-10
Table 3.1.16 Electrical characteristics (Extended operating temperature version) .....	3-11
Table 3.1.17 A-D converter characteristics (Extended operating temperature version) .....	3-11
Table 3.1.18 D-A converter characteristics (Extended operating temperature version) .....	3-12
Table 3.1.19 Timing requirements (Extended operating temperature version) .....	3-13
Table 3.1.20 Switching characteristics (Extended operating temperature version) .....	3-13

## List of tables

---

Table 3.1.21 Timing requirements in memory expansion mode and microprocessor mode (Extended operating temperature version) .....	3-14
Table 3.1.22 Switching characteristics in memory expansion mode and microprocessor mode (Extended operating temperature version) .....	3-14
Table 3.1.23 Absolute maximum ratings (High-speed version) .....	3-15
Table 3.1.24 Recommended operating conditions (High-speed version) .....	3-15
Table 3.1.25 Electrical characteristics (High-speed version) .....	3-16
Table 3.1.26 A-D converter characteristics (High-speed version) .....	3-16
Table 3.1.27 D-A converter characteristics (High-speed version) .....	3-17
Table 3.1.28 Timing requirements (1) (High-speed version) .....	3-18
Table 3.1.29 Timing requirements (2) (High-speed version) .....	3-18
Table 3.1.30 Switching characteristics (1) (High-speed version) .....	3-19
Table 3.1.31 Switching characteristics (2) (High-speed version) .....	3-19
Table 3.1.32 Timing requirements in memory expansion mode and microprocessor mode (1) (High-speed version) .....	3-20
Table 3.1.33 Switching characteristics in memory expansion mode and microprocessor mode (1) (High-speed version) .....	3-20
Table 3.1.34 Timing requirements in memory expansion mode and microprocessor mode (2) (High-speed version) .....	3-21
Table 3.1.35 Switching characteristics in memory expansion mode and microprocessor mode (2) (High-speed version) .....	3-21
Table 3.3.1 Programming adapter .....	3-34
Table 3.3.2 Setting of programming adapter switch .....	3-34
Table 3.3.3 Setting of PROM programmer address .....	3-35
Table 3.5.1 Function of CNTR0/CNTR1 edge switch bit .....	3-47



# CHAPTER 1

## **HARDWARE**

DESCRIPTION  
FEATURES  
APPLICATIONS  
PIN CONFIGURATION  
FUNCTIONAL BLOCK  
PIN DESCRIPTION  
PART NUMBERING  
GROUP EXPANSION  
FUNCTIONAL DESCRIPTION  
NOTES ON PROGRAMMING  
DATA REQUIRED FOR MASK  
ORDERS  
ROM PROGRAMMING METHOD  
FUNCTIONAL DESCRIPTION  
SUPPLEMENT



# HARDWARE

## DESCRIPTION/FEATURES/APPLICATIONS/PIN CONFIGURATION

### DESCRIPTION

The 3806 group is 8-bit microcomputer based on the 740 family core technology.

The 3806 group is designed for controlling systems that require analog signal processing and include two serial I/O functions, A-D converters, and D-A converters.

The various microcomputers in the 3806 group include variations of internal memory size and packaging. For details, refer to the section on part numbering.

For details on availability of microcomputers in the 3806 group, refer to the section on group expansion.

### FEATURES

- Basic machine-language instructions ..... 71
- Memory size
  - ROM ..... 12 K to 48 K bytes
  - RAM ..... 384 to 1024 bytes
- Programmable input/output ports ..... 72
- Interrupts ..... 16 sources, 16 vectors
- Timers ..... 8 bit X 4
- Serial I/O1 ..... 8-bit X 1 (UART or Clock-synchronized)
- Serial I/O2 ..... 8-bit X 1 (Clock-synchronized)
- A-D converter ..... 8-bit X 8 channels
- D-A converter ..... 8-bit X 2 channels

- Clock generating circuit ..... Internal feedback resistor (connect to external ceramic resonator or quartz-crystal)
- Memory expansion possible

Specification (unit)	Standard	Extended operating temperature version	High-speed version
Minimum instruction execution time (μs)	0.5	0.5	0.4
Oscillation frequency (MHz)	8	8	10
Power source voltage (V)	3.0 to 5.5	4.0 to 5.5	2.7 to 5.5
Power dissipation (mW)	32	32	40
Operating temperature range (°C)	-20 to 85	-40 to 85	-20 to 85

### APPLICATIONS

Office automation, VCRs, tuners, musical instruments, cameras, air conditioners, etc.

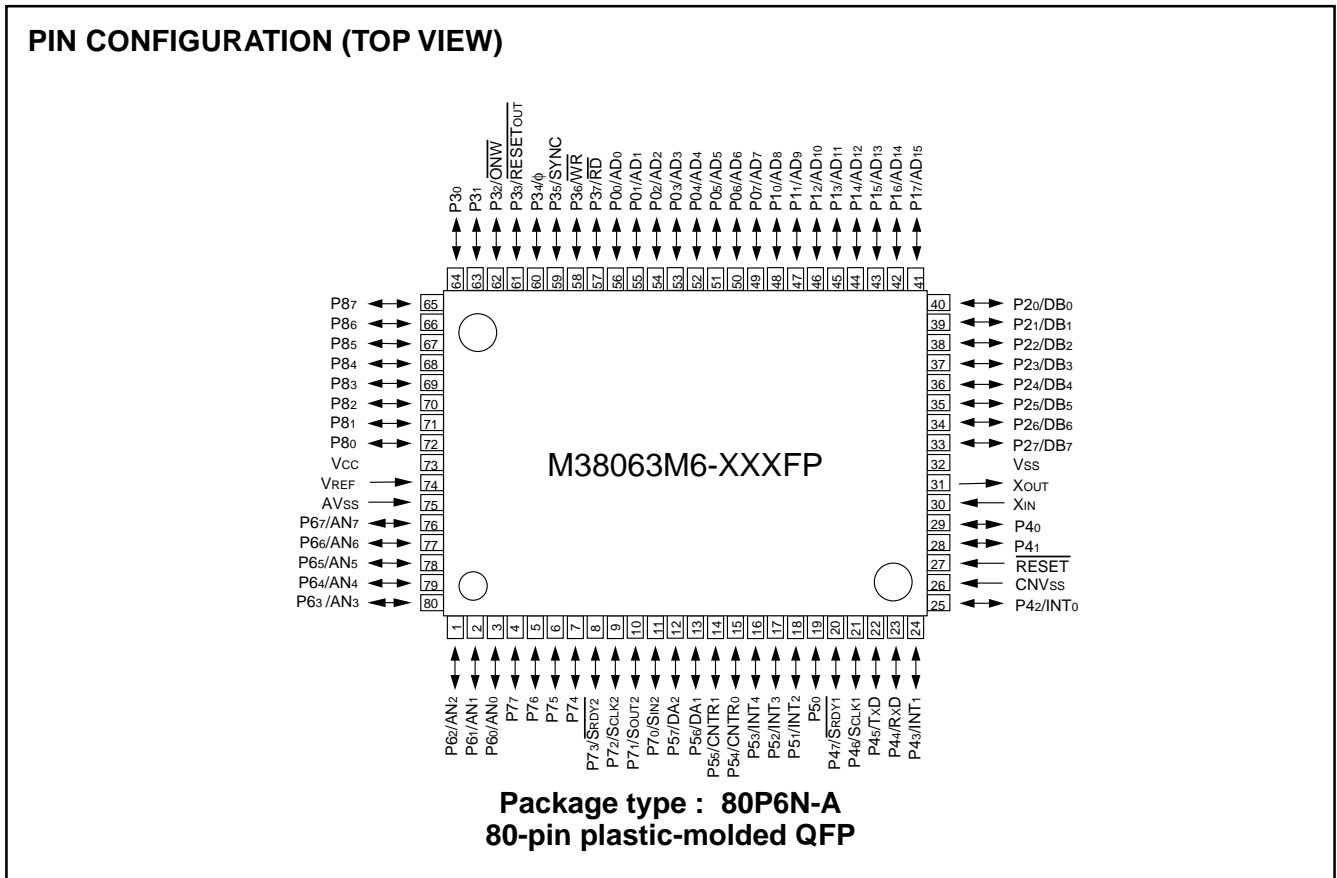

Fig. 1 Pin configuration of M38063M6-XXXXFP

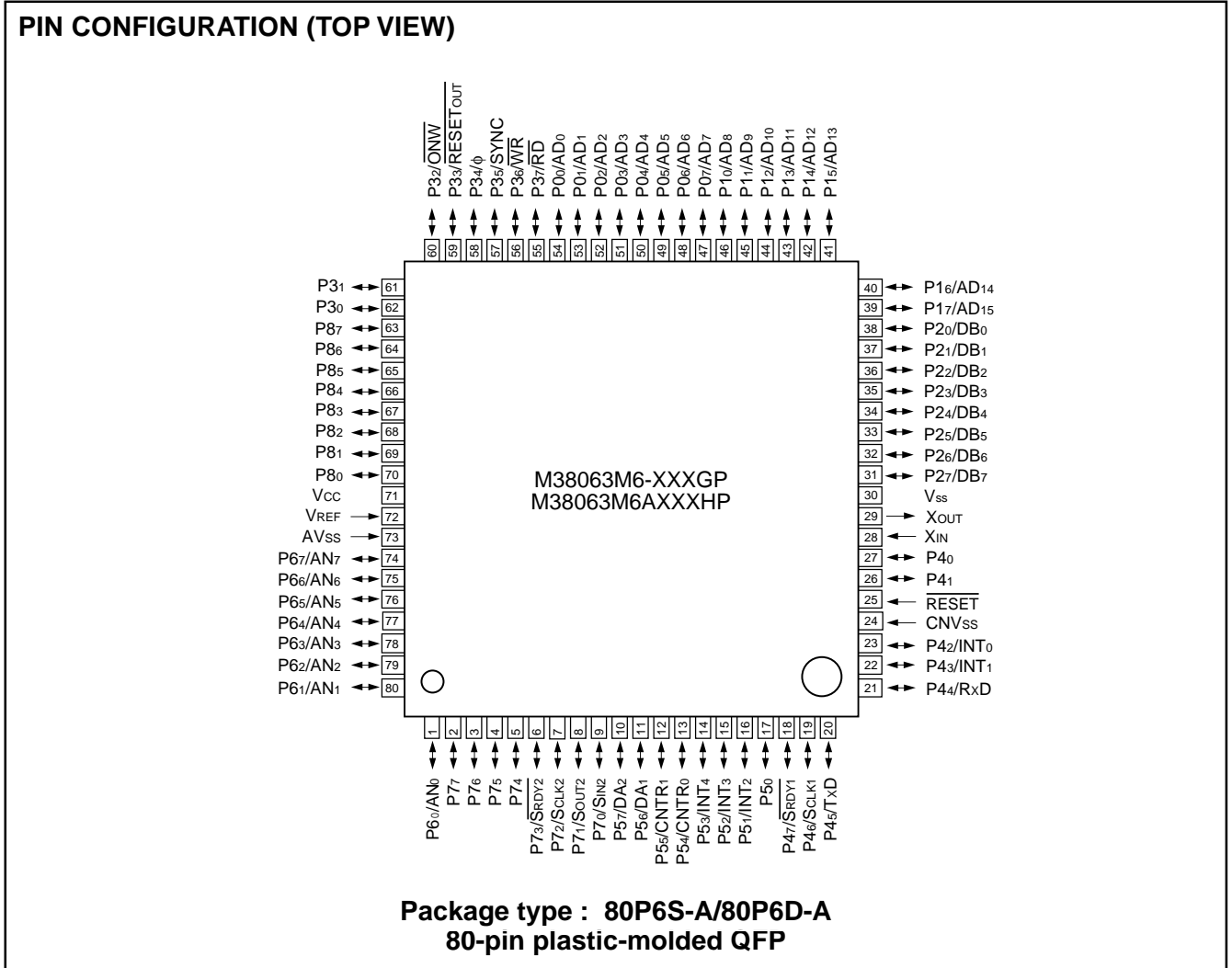

Fig. 2 Pin configuration of M38063M6-XXXGP and M38063M6AXXXHP

# HARDWARE

## FUNCTIONAL BLOCK

### FUNCTIONAL BLOCK

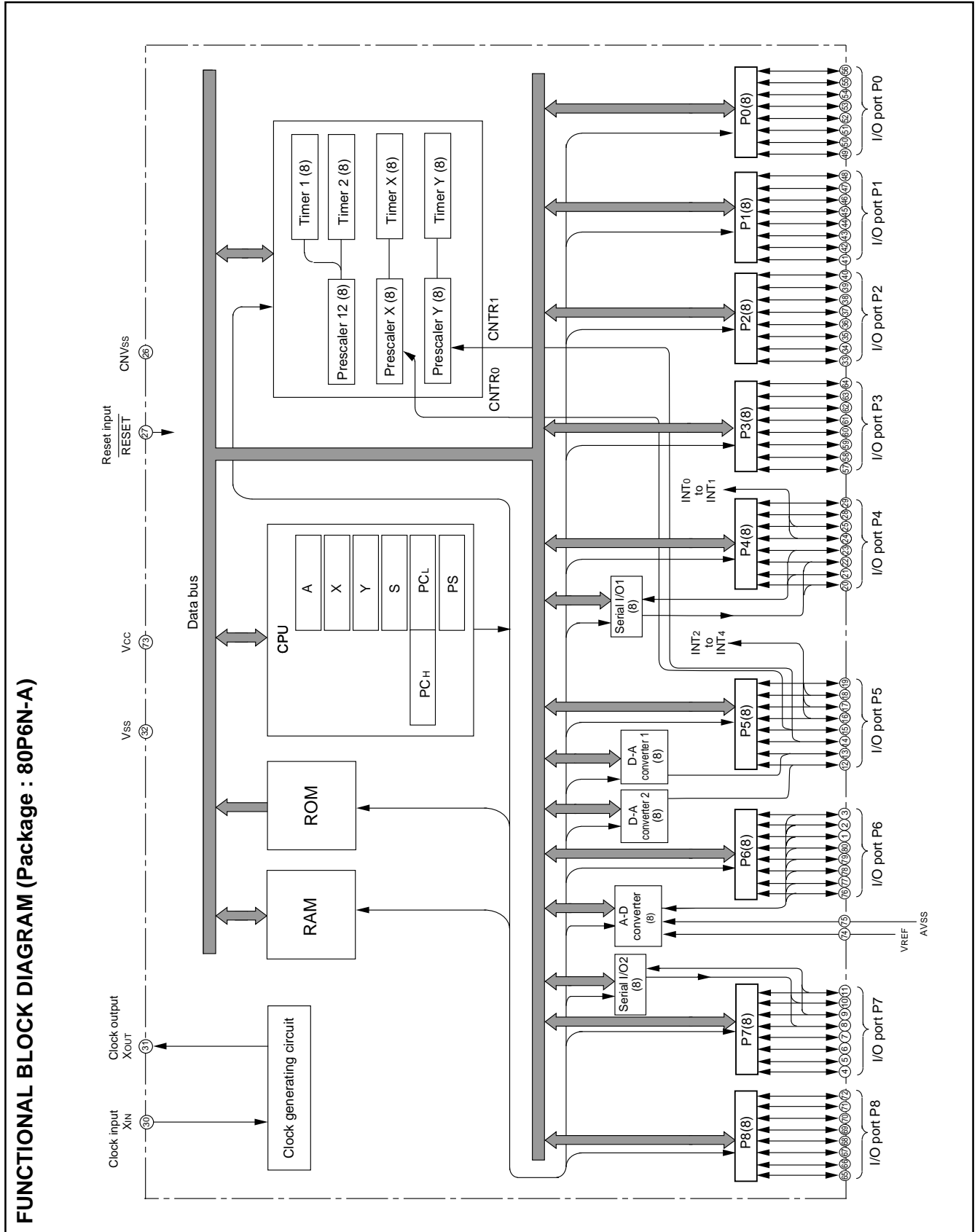

Fig. 3 Functional block diagram

### PIN DESCRIPTION

**Table 1. Pin description (1)**

Pin	Name	Function		
			Function except a port function	
VCC	Power source	<ul style="list-style-type: none"> <li>Apply voltage of 3.0 V to 5.5 V to VCC, and 0 V to VSS. (Extended operating temperature version : 4.0 V to 5.5 V)</li> <li>(High-speed version : 2.7 V to 5.5 V)</li> </ul>		
VSS				
CNVSS	CNVSS	<ul style="list-style-type: none"> <li>This pin controls the operation mode of the chip.</li> <li>Normally connected to VSS.</li> <li>If this pin is connected to VCC, the internal ROM is inhibited and external memory is accessed.</li> </ul>		
VREF	Analog reference voltage	<ul style="list-style-type: none"> <li>Reference voltage input pin for A-D and D-A converters</li> </ul>		
AVSS	Analog power source	<ul style="list-style-type: none"> <li>GND input pin for A-D and D-A converters</li> <li>Connect to VSS.</li> </ul>		
RESET	Reset input	<ul style="list-style-type: none"> <li>Reset input pin for active "L"</li> </ul>		
XIN	Clock input	<ul style="list-style-type: none"> <li>Input and output signals for the internal clock generating circuit.</li> <li>Connect a ceramic resonator or quartz-crystal oscillator between the XIN and XOUT pins to set the oscillation frequency.</li> <li>If an external clock is used, connect the clock source to the XIN pin and leave the XOUT pin open.</li> <li>The clock is used as the oscillating source of system clock.</li> </ul>		
XOUT	Clock output			
P00 – P07	I/O port P0	<ul style="list-style-type: none"> <li>8 bit CMOS I/O port</li> <li>I/O direction register allows each pin to be individually programmed as either input or output.</li> <li>At reset this port is set to input mode.</li> <li>In modes other than single-chip, these pins are used as address, data, and control bus I/O pins.</li> <li>CMOS compatible input level</li> <li>CMOS 3-state output structure</li> </ul>		
P10 – P17	I/O port P1			
P20 – P27	I/O port P2			
P30 – P37	I/O port P3			
P40, P41	I/O port P4	<ul style="list-style-type: none"> <li>8-bit CMOS I/O port with the same function as port P0</li> <li>CMOS compatible input level</li> <li>CMOS 3-state output structure</li> </ul>		
P42/INT0, P43/INT1				<ul style="list-style-type: none"> <li>External interrupt input pin</li> </ul>
P44/RxD, P45/TxD, P46/SCLK1, P47/SRDY1				<ul style="list-style-type: none"> <li>Serial I/O1 I/O pins</li> </ul>
P50	I/O port P5	<ul style="list-style-type: none"> <li>8-bit CMOS I/O port with the same function as port P0</li> <li>CMOS compatible input level</li> <li>CMOS 3-state output structure</li> </ul>		
P51/INT2 – P53/INT4				<ul style="list-style-type: none"> <li>External interrupt input pin</li> </ul>
P54/CNTR0, P55/CNTR1				<ul style="list-style-type: none"> <li>Timer X and Timer Y I/O pins</li> </ul>
P56/DA1, P57/DA2				<ul style="list-style-type: none"> <li>D-A conversion output pins</li> </ul>
P60/AN0 – P67/AN7	I/O port P6	<ul style="list-style-type: none"> <li>8-bit CMOS I/O port with the same function as port P0</li> <li>CMOS compatible input level</li> <li>CMOS 3-state output structure</li> </ul>	<ul style="list-style-type: none"> <li>A-D conversion input pins</li> </ul>	

# HARDWARE

## PIN DESCRIPTION

---

Table 2. Pin description (2)

Pin	Name	Function	Function except a port function
P70/SIN2, P71/SOUT2, P72/SCLK2, P73/SRDY2	I/O port P7	<ul style="list-style-type: none"><li>• 8-bit I/O port with the same function as port P0</li><li>• CMOS compatible input level</li><li>• N-channel open-drain output structure</li></ul>	<ul style="list-style-type: none"><li>• Serial I/O2 I/O pins</li></ul>
P74 – P77			
P80 – P87	I/O port P8	<ul style="list-style-type: none"><li>• 8-bit CMOS I/O port with the same function as port P0</li><li>• CMOS compatible input level</li><li>• CMOS 3-state output structure</li></ul>	

### PART NUMBERING

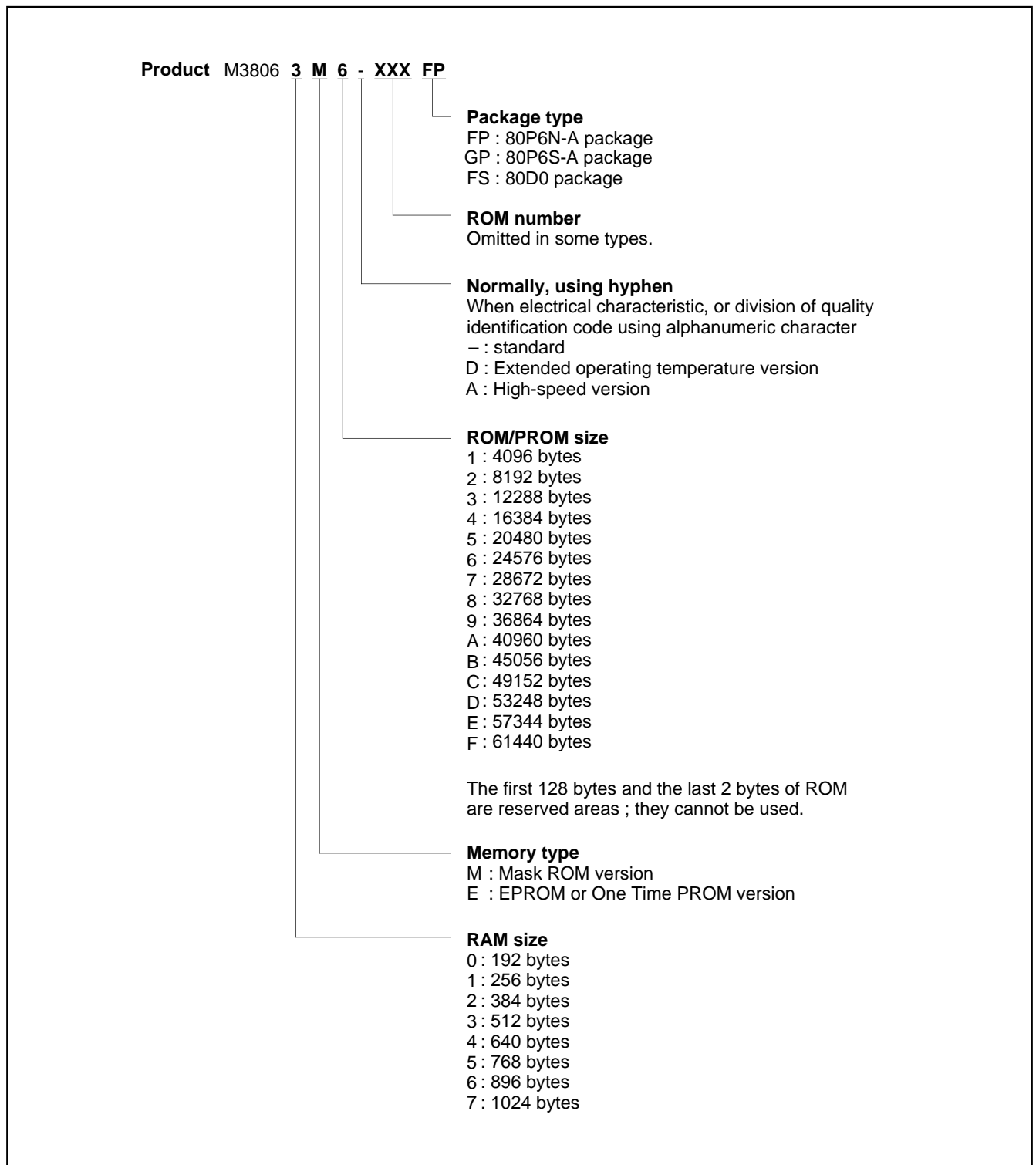

Fig. 4 Part numbering

# HARDWARE

## GROUP EXPANSION

---

Currently supported products are listed below.

**Table 3. List of supported products**

**As of September 1995**

Product name	(P) ROM size (bytes) ROM size for User in ( )	RAM size (bytes)	Package	Remarks		
M38062M3-XXXFP	12288	384	80P6N-A	Mask ROM version		
M38062M3-XXXGP	(12158)		80P6S-A	Mask ROM version		
M38062M4-XXXFP	16384	384	80P6N-A	Mask ROM version		
M38062M4-XXXGP	(16254)		80P6S-A	Mask ROM version		
M38063M6-XXXFP	24576 (24446)	512	80P6N-A	Mask ROM version		
M38063E6-XXXFP				One Time PROM version		
M38063E6FP			One Time PROM version (blank)			
M38063M6-XXXGP			Mask ROM version			
M38063E6-XXXGP			One Time PROM version			
M38063E6GP			One Time PROM version (blank)			
M38063E6FS			80D0	EPROM version		
M38067M8-XXXFP			32768	1024	80P6N-A	Mask ROM version
M38067M8-XXXGP			(32638)		80P6S-A	Mask ROM version
M38067MC-XXXFP			49152 (49022)	1024	80P6N-A	Mask ROM version
M38067EC-XXXFP	One Time PROM version					
M38067ECFP	One Time PROM version (blank)					
M38067MC-XXXGP	Mask ROM version					
M38067EC-XXXGP	One Time PROM version					
M38067ECGP	One Time PROM version (blank)					

### GROUP EXPANSION

Mitsubishi plans to expand the 3806 group as follows:

- (1) Support for mask ROM, One Time PROM, and EPROM versions  
 ROM/PROM capacity ..... 12 K to 48 K bytes  
 RAM capacity ..... 384 to 1024 bytes

(2) Packages

- 80P6N-A ..... 0.8 mm-pitch plastic molded QFP  
 80P6S-A ..... 0.65 mm-pitch plastic molded QFP  
 80D0 ..... 0.8 mm-pitch ceramic LCC (EPROM version)

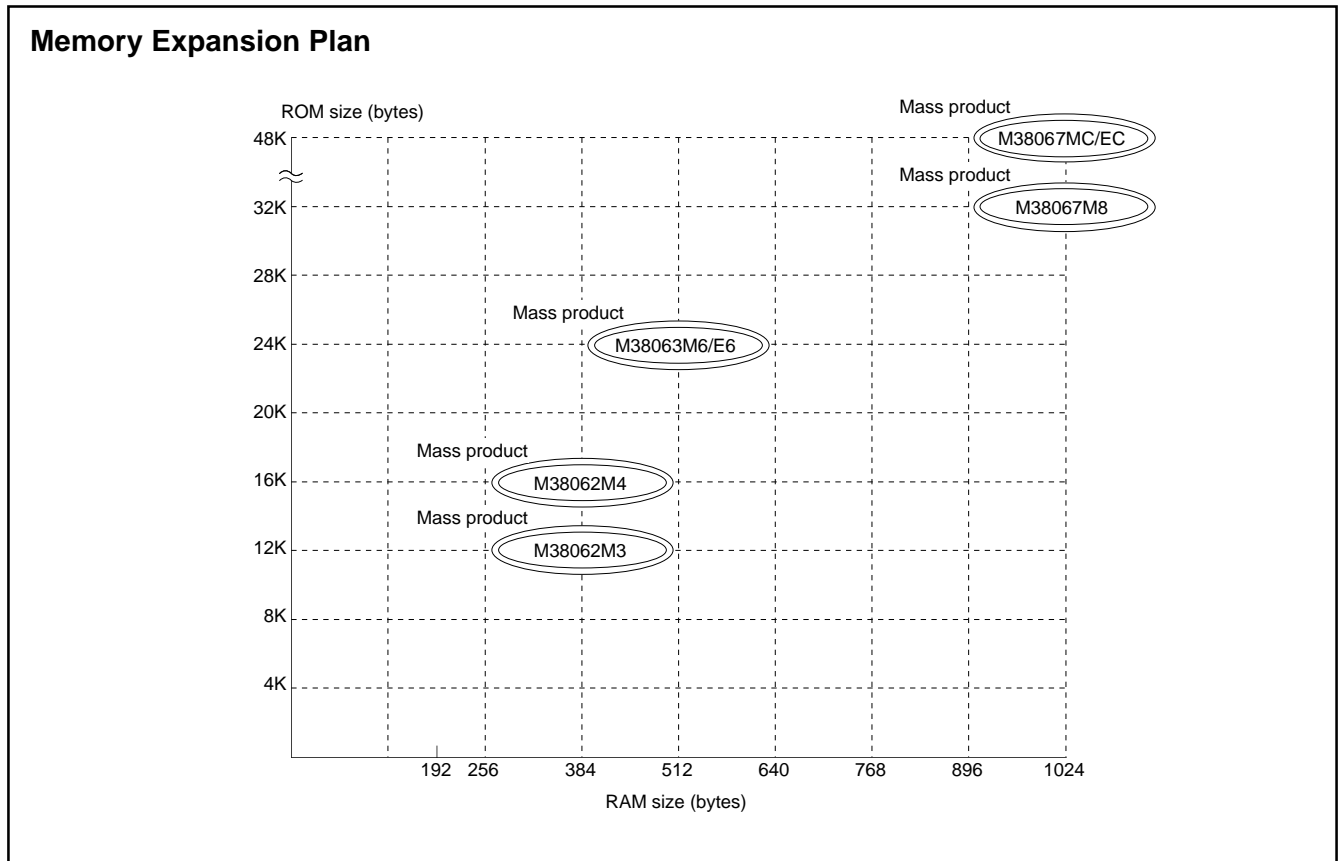

Fig. 5 Memory expansion plan



# HARDWARE

## GROUP EXPANSION

### GROUP EXPANSION (EXTENDED OPERATING TEMPERATURE VERSION)

Mitsubishi plans to expand the 3806 group (extended operating temperature version) as follows:

- (1) Support for mask ROM version  
 ROM/PROM capacity ..... 12 K to 48 K bytes  
 RAM capacity ..... 384 to 1024 bytes

- (2) Packages  
 80P6N-A ..... 0.8 mm-pitch plastic molded QFP

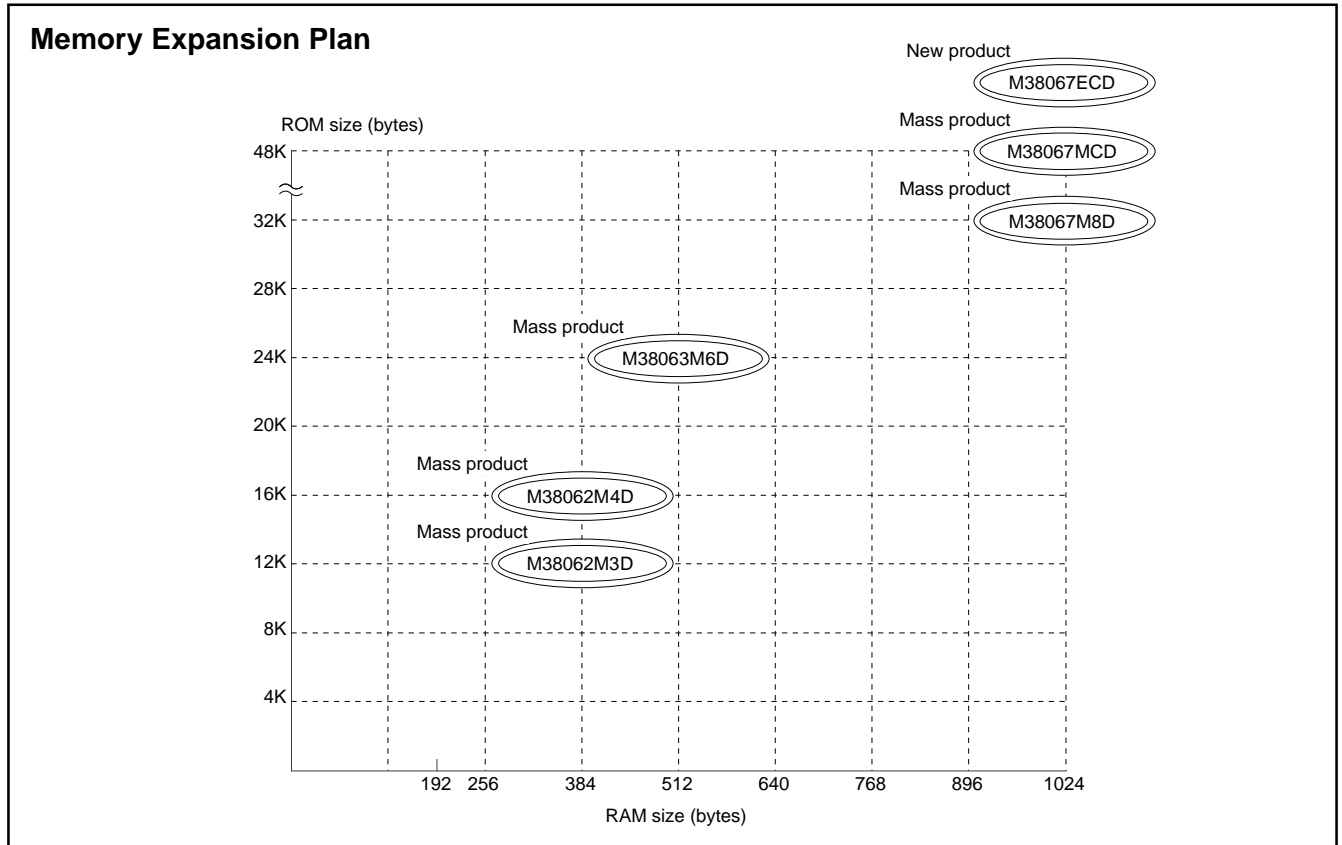

Fig. 6 Memory expansion plan (Extended operating temperature version)

Currently supported products are listed below.

Table 4. List of supported products (Extended operating temperature version)

As of September 1995

Product name	(P) ROM size (bytes) ROM size for User in ( )	RAM size (bytes)	Package	Remarks
M38062M3DXXXFP	12288(12158)	384	80P6N-A	Mask ROM version
M38062M4DXXXFP	16384(16254)	384		Mask ROM version
M38063M6DXXXFP	24576(24446)	512		Mask ROM version
M38067M8DXXXFP	32768(32638)	1024		Mask ROM version
M38067MCDXXXFP	49152(49022)	1024		Mask ROM version
M38067ECDXXXFP				One Time PROM version
M38067ECDFP				One Time PROM version (blank)

### GROUP EXPANSION (HIGH-SPEED VERSION)

Mitsubishi plans to expand the 3806 group (high-speed version) as follows:

- (1) Support for mask ROM, One Time PROM, and EPROM versions  
 ROM/PROM capacity ..... 24 K to 48 K bytes  
 RAM capacity ..... 512 to 1024 bytes

- (2) Packages  
 80P6N-A ..... 0.8 mm-pitch plastic molded QFP  
 80P6S-A ..... 0.65 mm-pitch plastic molded QFP  
 80P6D-A ..... 0.5 mm-pitch plastic molded QFP  
 80D0 ..... 0.8 mm-pitch ceramic LCC (EPROM version)

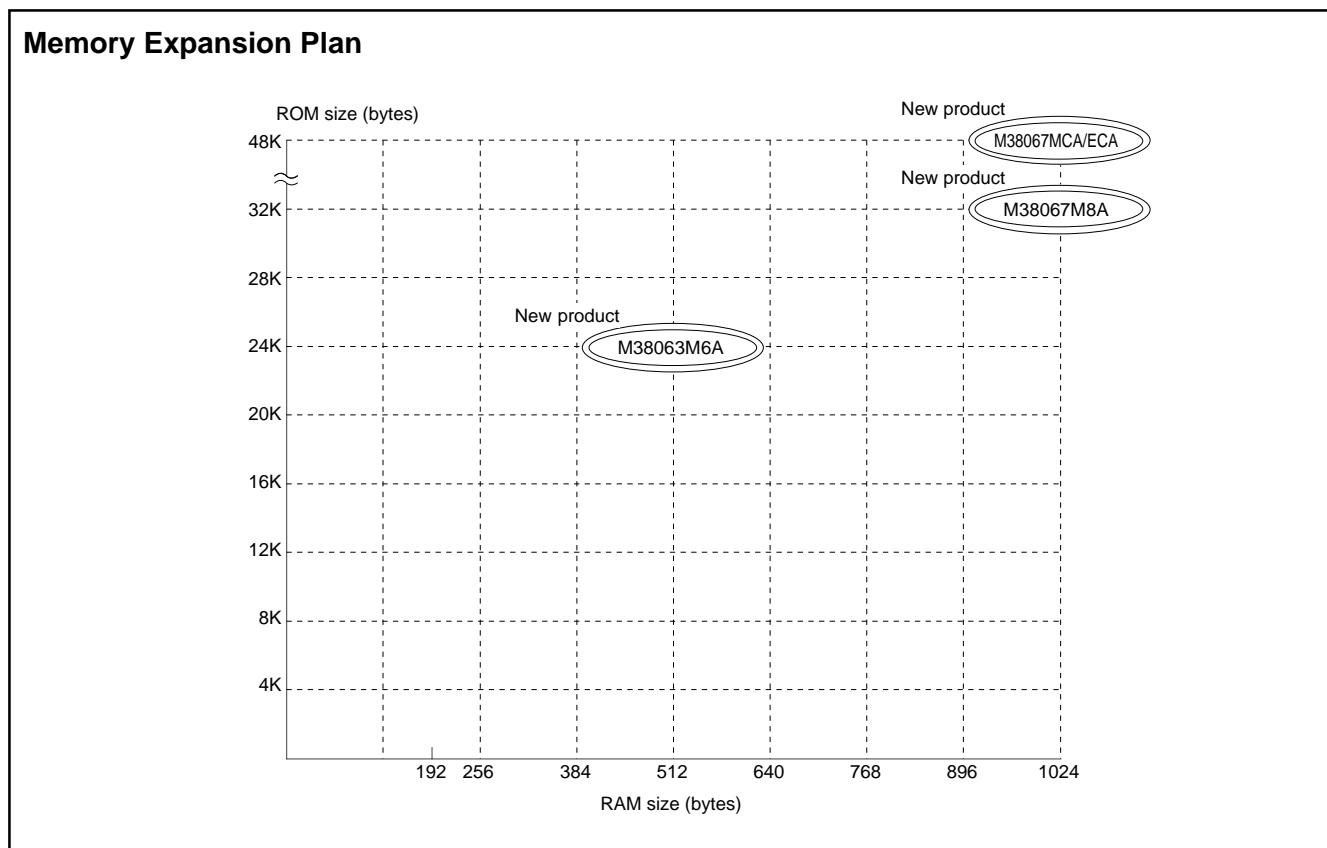

Fig. 7 Memory expansion plan (High-speed version)

Currently supported products are listed below.

Table 5. List of supported products (High-speed version)

As of September 1995

Product name	(P) ROM size (bytes) ROM size for User in ( )	RAM size (bytes)	Package	Remarks
M38063M6AXXFP	24576 (24446)	512	80P6N-A	Mask ROM version
M38063M6AXXGP			80P6S-A	Mask ROM version
M38063M6AXXHP			80P6D-A	Mask ROM version
M38067M8AXXFP	32768 (32638)	1024	80P6N-A	Mask ROM version
M38067M8AXXGP			80P6S-A	Mask ROM version
M38067MCAXXFP	49152 (49022)	1024	80P6N-A	Mask ROM version
M38067ECAXXFP				One Time PROM version
M38067ECAFP				One Time PROM version (blank)
M38067MCAXXGP			80P6S-A	Mask ROM version
M38067ECAXXGP				One Time PROM version
M38067ECAGP				One Time PROM version (blank)
M38067ECAFS			80D0	EPROM version

# HARDWARE

## FUNCTIONAL DESCRIPTION

### FUNCTIONAL DESCRIPTION Central Processing Unit (CPU)

The 3806 group uses the standard 740 family instruction set. Refer to the table of 740 family addressing modes and machine instructions or the SERIES 740 <Software> User's Manual for details on the instruction set.

Machine-resident 740 family instructions are as follows:

The FST and SLW instruction cannot be used.

The STP, WIT, MUL, and DIV instruction can be used.

The central processing unit (CPU) has the six registers.

### Accumulator (A)

The accumulator is an 8-bit register. Data operations such as data transfer, etc., are executed mainly through the accumulator.

### Index register X (X), Index register Y (Y)

Both index register X and index register Y are 8-bit registers. In the index addressing modes, the value of the OPERAND is added to the contents of register X or register Y and specifies the real address.

When the T flag in the processor status register is set to "1", the value contained in index register X becomes the address for the second OPERAND.

### Stack pointer (S)

The stack pointer is an 8-bit register used during subroutine calls and interrupts. The stack is used to store the current address data and processor status when branching to subroutines or interrupt routines.

The lower eight bits of the stack address are determined by the contents of the stack pointer. The upper eight bits of the stack address are determined by the Stack Page Selection Bit. If the Stack Page Selection Bit is "0", then the RAM in the zero page is used as the stack area. If the Stack Page Selection Bit is "1", then RAM in page 1 is used as the stack area.

The Stack Page Selection Bit is located in the SFR area in the zero page. Note that the initial value of the Stack Page Selection Bit varies with each microcomputer type. Also some microcomputer types have no Stack Page Selection Bit and the upper eight bits of the stack address are fixed.

The operations of pushing register contents onto the stack and popping them from the stack are shown in Fig. 9.

### Program counter (PC)

The program counter is a 16-bit counter consisting of two 8-bit registers PCH and PCL. It is used to indicate the address of the next instruction to be executed.

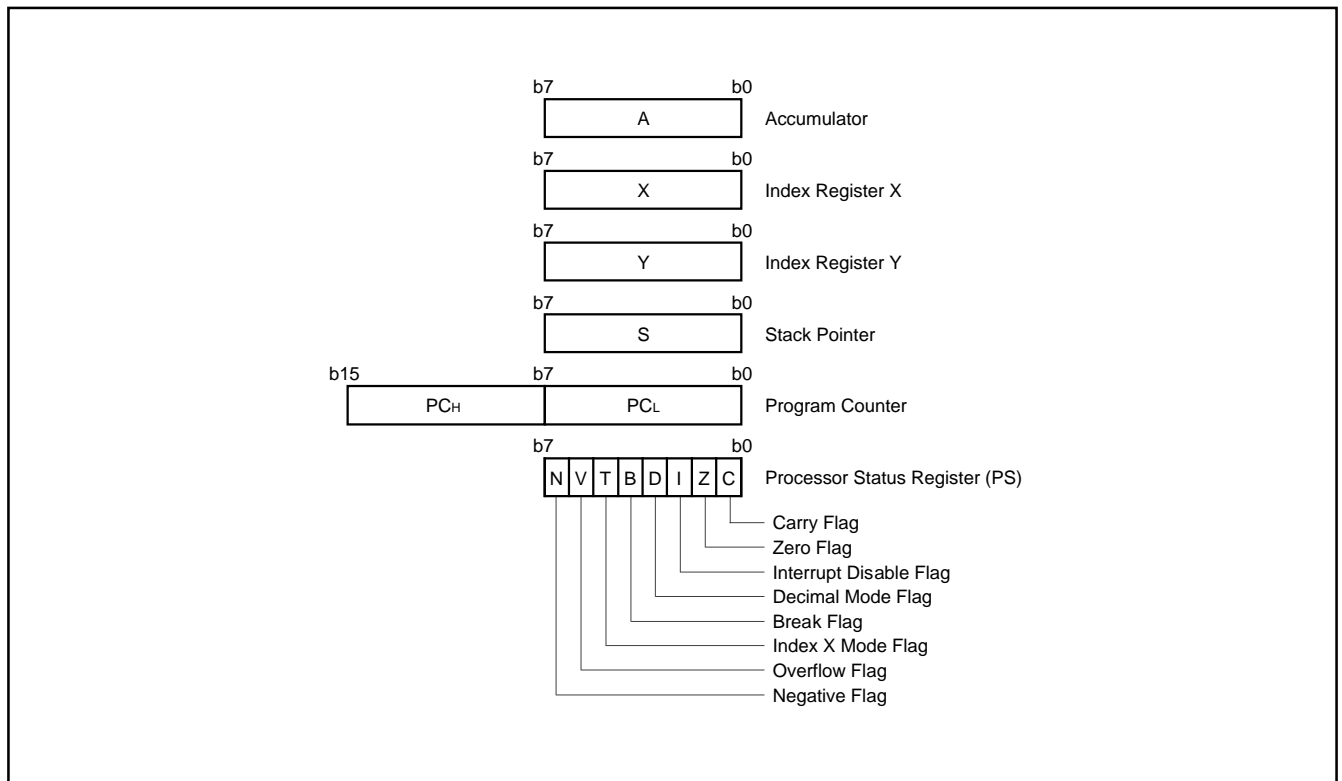
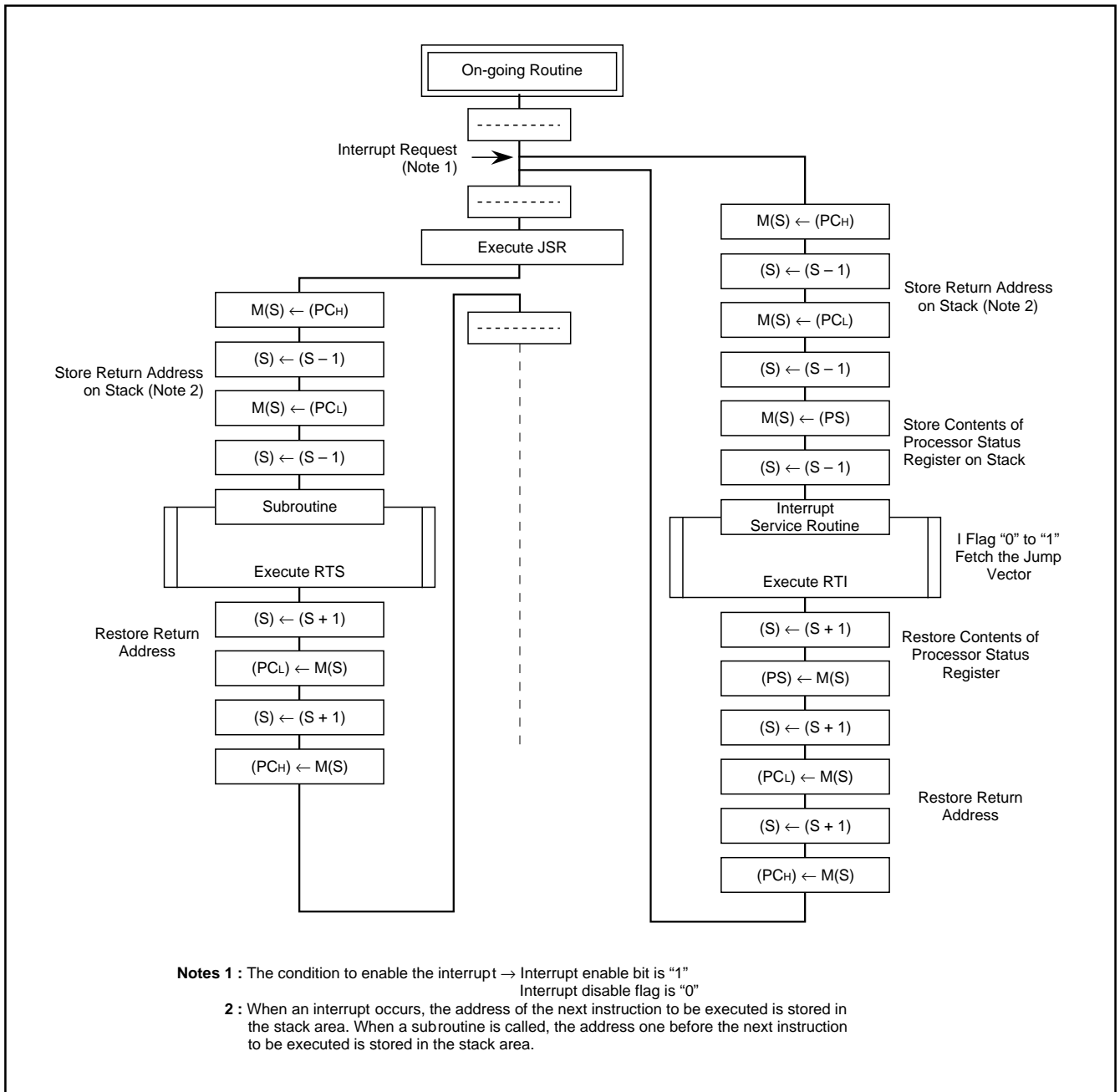

Fig. 8 740 Family CPU register structure



**Fig. 9 Register push and pop at interrupt generation and subroutine call**

**Table 6. Push and pop instructions of accumulator or processor status register**

	Push instruction to stack	Pop instruction from stack
Accumulator	PHA	PLA
Processor status register	PHP	PLP

# HARDWARE

## FUNCTIONAL DESCRIPTION

### Processor status register (PS)

The processor status register is an 8-bit register consisting of flags which indicate the status of the processor after an arithmetic operation. Branch operations can be performed by testing the Carry (C) flag, Zero (Z) flag, Overflow (V) flag, or the Negative (N) flag. In decimal mode, the Z, V, N flags are not valid.

After reset, the Interrupt disable (I) flag is set to "1", but all other flags are undefined. Since the Index X mode (T) and Decimal mode (D) flags directly affect arithmetic operations, they should be initialized in the beginning of a program.

(1) Carry flag (C)

The C flag contains a carry or borrow generated by the arithmetic logic unit (ALU) immediately after an arithmetic operation. It can also be changed by a shift or rotate instruction.

(2) Zero flag (Z)

The Z flag is set if the result of an immediate arithmetic operation or a data transfer is "0", and cleared if the result is anything other than "0".

(3) Interrupt disable flag (I)

The I flag disables all interrupts except for the interrupt generated by the BRK instruction.

Interrupts are disabled when the I flag is "1".

When an interrupt occurs, this flag is automatically set to "1" to prevent other interrupts from interfering until the current interrupt is serviced.

(4) Decimal mode flag (D)

The D flag determines whether additions and subtractions are executed in binary or decimal. Binary arithmetic is executed when this flag is "0"; decimal arithmetic is executed when it is "1". Decimal correction is automatic in decimal mode. Only the ADC and SBC instructions can be used for decimal arithmetic.

(5) Break flag (B)

The B flag is used to indicate that the current interrupt was generated by the BRK instruction. The BRK flag in the processor status register is always "0". When the BRK instruction is used to generate an interrupt, the processor status register is pushed onto the stack with the break flag set to "1". The saved processor status is the only place where the break flag is ever set.

(6) Index X mode flag (T)

When the T flag is "0", arithmetic operations are performed between accumulator and memory, e.g. the results of an operation between two memory locations is stored in the accumulator. When the T flag is "1", direct arithmetic operations and direct data transfers are enabled between memory locations, i.e. between memory and memory, memory and I/O, and I/O and I/O. In this case, the result of an arithmetic operation performed on data in memory location 1 and memory location 2 is stored in memory location 1. The address of memory location 1 is specified by index register X, and the address of memory location 2 is specified by normal addressing modes.

(7) Overflow flag (V)

The V flag is used during the addition or subtraction of one byte of signed data. It is set if the result exceeds + 127 to -128. When the BIT instruction is executed, bit 6 of the memory location operated on by the BIT instruction is stored in the overflow flag.

(8) Negative flag (N)

The N flag is set if the result of an arithmetic operation or data transfer is negative. When the BIT instruction is executed, bit 7 of the memory location operated on by the BIT instruction is stored in the negative flag.

Table 7. Set and clear instructions of each bit of processor status register

	C flag	Z flag	I flag	D flag	B flag	T flag	V flag	N flag
Set instruction	SEC	—	SEI	SED	—	SET	—	—
Clear instruction	CLC	—	CLI	CLD	—	CLT	CLV	—

**CPU mode register**

The CPU mode register is allocated at address 003B16.  
The CPU mode register contains the stack page selection bit.

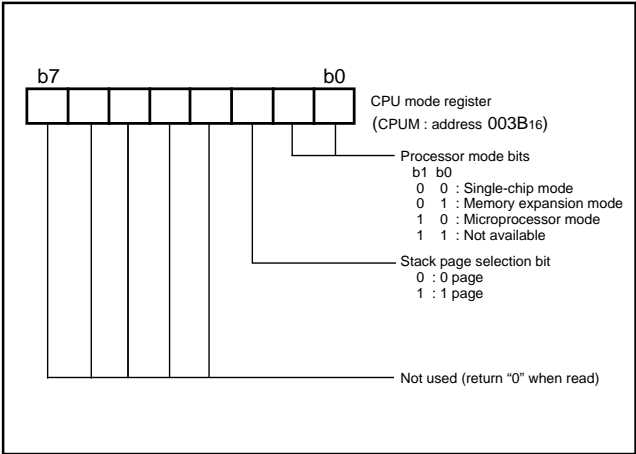

**Fig. 10 Structure of CPU mode register**

# HARDWARE

## FUNCTIONAL DESCRIPTION

### Memory

#### Special function register (SFR) area

The Special Function Register area in the zero page contains control registers such as I/O ports and timers.

#### RAM

RAM is used for data storage and for stack area of subroutine calls and interrupts.

#### ROM

The first 128 bytes and the last 2 bytes of ROM are reserved for device testing and the rest is user area for storing programs.

#### Interrupt vector area

The interrupt vector area contains reset and interrupt vectors.

### Zero page

The 256 bytes from addresses  $0000_{16}$  to  $00FF_{16}$  are called the zero page area. The internal RAM and the special function registers (SFR) are allocated to this area.

The zero page addressing mode can be used to specify memory and register addresses in the zero page area. Access to this area with only 2 bytes is possible in the zero page addressing mode.

### Special page

The 256 bytes from addresses  $FF00_{16}$  to  $FFFF_{16}$  are called the special page area. The special page addressing mode can be used to specify memory addresses in the special page area. Access to this area with only 2 bytes is possible in the special page addressing mode.

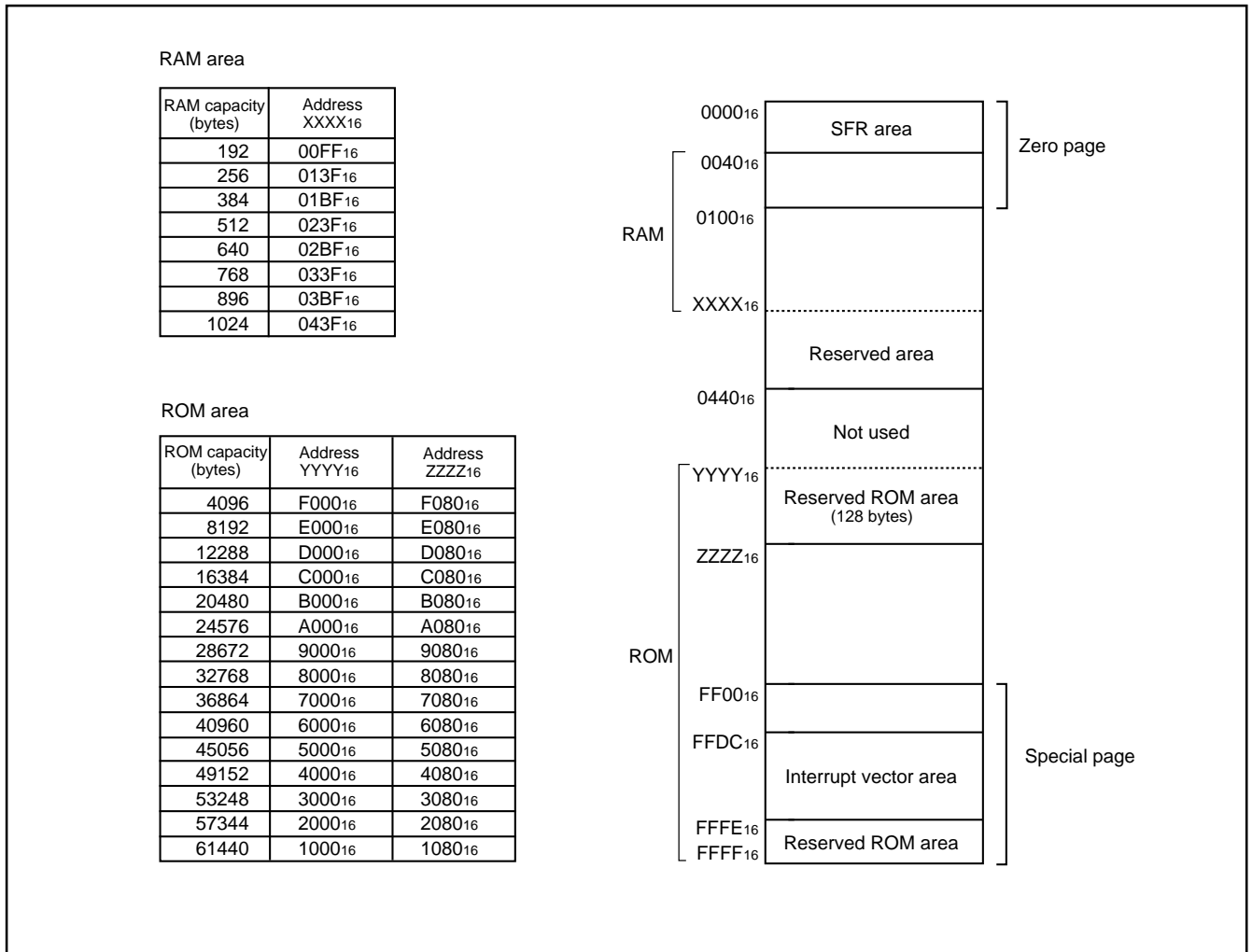

Fig. 11 Memory map diagram

0000 <sub>16</sub>	Port P0 (P0)	0020 <sub>16</sub>	Prescaler 12 (PRE12)
0001 <sub>16</sub>	Port P0 direction register (P0D)	0021 <sub>16</sub>	Timer 1 (T1)
0002 <sub>16</sub>	Port P1 (P1)	0022 <sub>16</sub>	Timer 2 (T2)
0003 <sub>16</sub>	Port P1 direction register (P1D)	0023 <sub>16</sub>	Timer XY mode register (TM)
0004 <sub>16</sub>	Port P2 (P2)	0024 <sub>16</sub>	Prescaler X (PREX)
0005 <sub>16</sub>	Port P2 direction register (P2D)	0025 <sub>16</sub>	Timer X (TX)
0006 <sub>16</sub>	Port P3 (P3)	0026 <sub>16</sub>	Prescaler Y (PREY)
0007 <sub>16</sub>	Port P3 direction register (P3D)	0027 <sub>16</sub>	Timer Y (TY)
0008 <sub>16</sub>	Port P4 (P4)	0028 <sub>16</sub>	
0009 <sub>16</sub>	Port P4 direction register (P4D)	0029 <sub>16</sub>	
000A <sub>16</sub>	Port P5 (P5)	002A <sub>16</sub>	
000B <sub>16</sub>	Port P5 direction register (P5D)	002B <sub>16</sub>	
000C <sub>16</sub>	Port P6 (P6)	002C <sub>16</sub>	
000D <sub>16</sub>	Port P6 direction register (P6D)	002D <sub>16</sub>	
000E <sub>16</sub>	Port P7 (P7)	002E <sub>16</sub>	
000F <sub>16</sub>	Port P7 direction register (P7D)	002F <sub>16</sub>	
0010 <sub>16</sub>	Port P8 (P8)	0030 <sub>16</sub>	
0011 <sub>16</sub>	Port P8 direction register (P8D)	0031 <sub>16</sub>	
0012 <sub>16</sub>		0032 <sub>16</sub>	
0013 <sub>16</sub>		0033 <sub>16</sub>	
0014 <sub>16</sub>		0034 <sub>16</sub>	AD/DA control register (ADCON)
0015 <sub>16</sub>		0035 <sub>16</sub>	A-D conversion register (AD)
0016 <sub>16</sub>		0036 <sub>16</sub>	D-A1 conversion register (DA1)
0017 <sub>16</sub>		0037 <sub>16</sub>	D-A2 conversion register (DA2)
0018 <sub>16</sub>	Transmit/Receive buffer register (TB/RB)	0038 <sub>16</sub>	
0019 <sub>16</sub>	Serial I/O1 status register (SIO1STS)	0039 <sub>16</sub>	
001A <sub>16</sub>	Serial I/O1 control register (SIO1CON)	003A <sub>16</sub>	Interrupt edge selection register (INTEDGE)
001B <sub>16</sub>	UART control register (UARTCON)	003B <sub>16</sub>	CPU mode register (CPUM)
001C <sub>16</sub>	Baud rate generator (BRG)	003C <sub>16</sub>	Interrupt request register 1 (IREQ1)
001D <sub>16</sub>	Serial I/O2 control register (SIO2CON)	003D <sub>16</sub>	Interrupt request register 2 (IREQ2)
001E <sub>16</sub>		003E <sub>16</sub>	Interrupt control register 1 (ICON1)
001F <sub>16</sub>	Serial I/O2 register (SIO2)	003F <sub>16</sub>	Interrupt control register 2 (ICON2)

**Fig. 12 Memory map of special function register (SFR)**



# HARDWARE

## FUNCTIONAL DESCRIPTION

### I/O Ports Direction registers

The 3806 group has 72 programmable I/O pins arranged in nine I/O ports (ports P0 to P8). The I/O ports have direction registers which determine the input/output direction of each individual pin. Each bit in a direction register corresponds to one pin, each pin can be set to be input port or output port.

When “0” is written to the bit corresponding to a pin, that pin becomes an input pin. When “1” is written to that bit, that pin becomes an output pin.

If data is read from a pin which is set to output, the value of the port output latch is read, not the value of the pin itself. Pins set to input are floating. If a pin set to input is written to, only the port output latch is written to and the pin remains floating.

**Table 8. List of I/O port functions**

Pin	Name	Input/Output	I/O Format	Non-Port Function	Related SFRs	Ref.No.			
P00 – P07	Port P0	Input/output, individual bits	CMOS 3-state output CMOS compatible input level	Address low-order byte output	CPU mode register	(1)			
P10 – P17	Port P1	Input/output, individual bits	CMOS 3-state output CMOS compatible input level	Address high-order byte output	CPU mode register				
P20 – P27	Port P2	Input/output, individual bits	CMOS 3-state output CMOS compatible input level	Data bus I/O	CPU mode register				
P30 – P37	Port P3	Input/output, individual bits	CMOS 3-state output CMOS compatible input level	Control signal I/O	CPU mode register				
P40, P41 P42/INT0, P43/INT1 P44/RxD, P45/TxD, P46/SCLK1, P47/SRDY1	Port P4	Input/output, individual bits	CMOS 3-state output CMOS compatible input level	External interrupt input	Interrupt edge selection register	(2)			
P50 P51/INT2, P52/INT3, P53/INT4 P54/CNTR0, P55/CNTR1 P56/DA1, P57/DA2				Port P5	Input/output, individual bits	CMOS 3-state output CMOS compatible input level	Serial I/O1 function I/O	Serial I/O1 control register	(3)
								UART control register	(4)
									(5)
						(6)			
						(1)			
				External interrupt input	Interrupt edge selection register	(2)			
				Timer X and Timer Y function I/O	Timer XY mode register	(7)			
				D-A conversion output	AD/DA control register	(8)			
P60/AN0 – P67/AN7	Port P6	Input/output, individual bits	CMOS 3-state output CMOS compatible input level	A-D conversion input		(9)			
P70/SIN2, P71/SOUT2, P72/SCLK2, P73/SRDY2 P74 – P77	Port P7	Input/output, individual bits	N-channel open-drain output CMOS compatible input level	Serial I/O2 function I/O	Serial I/O2 control register	(10)			
						(11)			
						(12)			
						(13)			
						(14)			
P80 – P87	Port P8	Input/output, individual bits	CMOS 3-state output CMOS compatible input level			(1)			

**Note 1:** For details of the functions of ports P0 to P3 in modes other than single-chip mode, and how to use double-function ports as function I/O ports, refer to the applicable sections.

**2:** Make sure that the input level at each pin is either 0 V or Vcc during execution of the STP instruction.

When an input level is at an intermediate potential, a current will flow from Vcc to Vss through the input-stage gate.

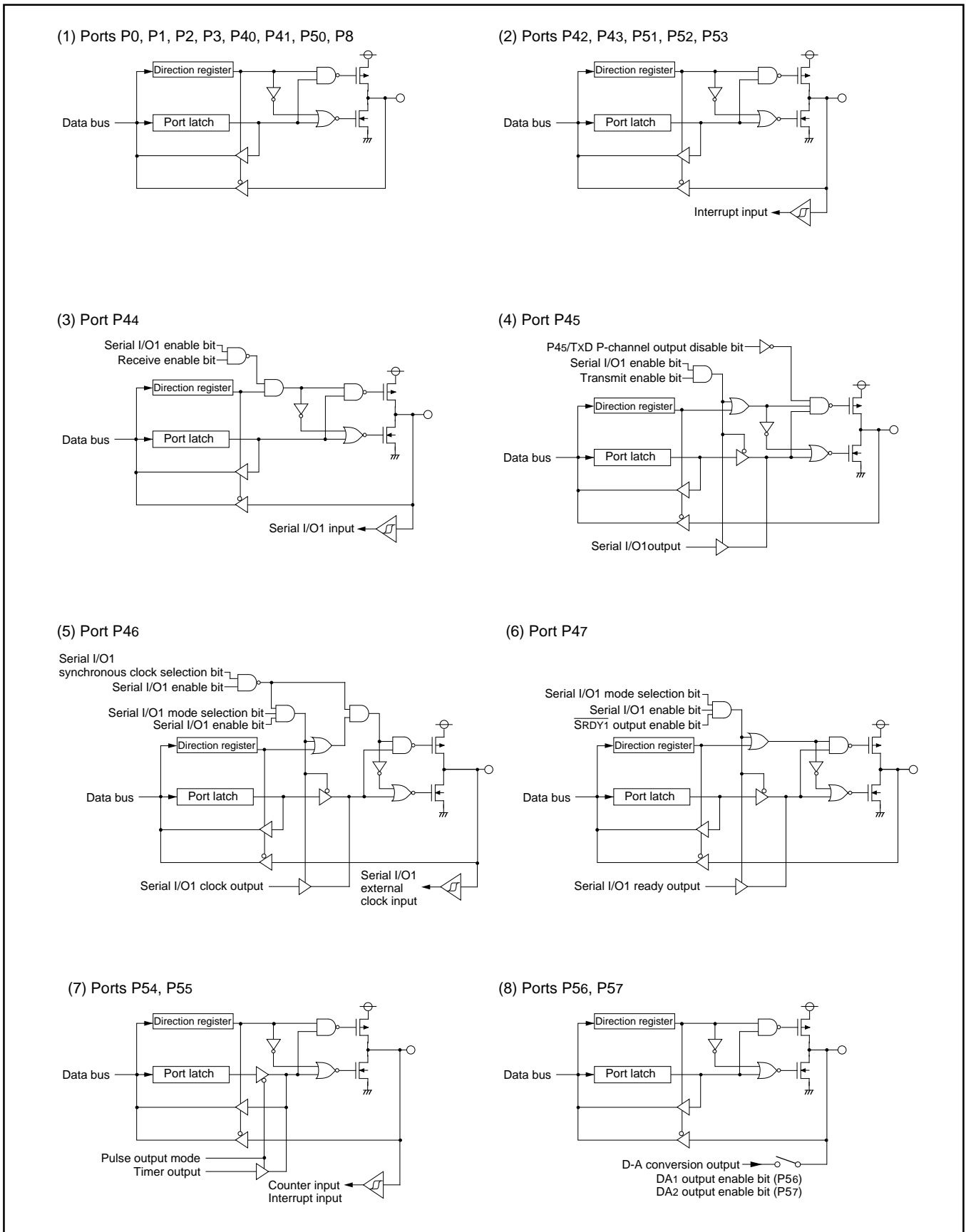

Fig. 13 Port block diagram (single-chip mode) (1)

# HARDWARE

## FUNCTIONAL DESCRIPTION

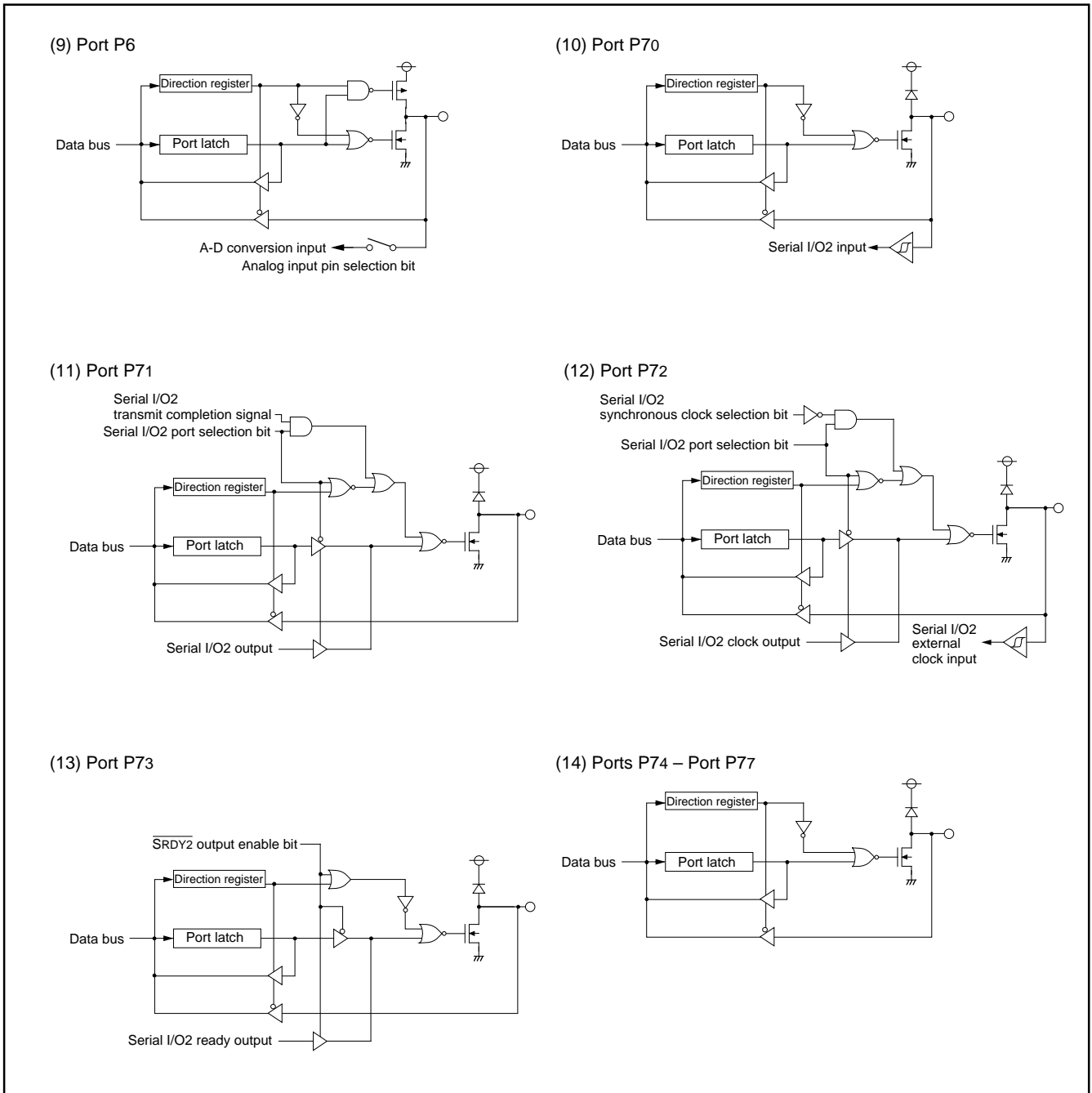

Fig. 14 Port block diagram (single-chip mode) (2)

### Interrupts

Interrupts occur by sixteen sources: seven external, eight internal, and one software.

### Interrupt control

Each interrupt is controlled by an interrupt request bit, an interrupt enable bit, and the interrupt disable flag except for the software interrupt set by the BRK instruction. An interrupt occurs if the corresponding interrupt request and enable bits are "1" and the interrupt disable flag is "0".

Interrupt enable bits can be set or cleared by software.

Interrupt request bits can be cleared by software, but cannot be set by software.

The BRK instruction cannot be disabled with any flag or bit. The I (interrupt disable) flag disables all interrupts except the BRK instruction interrupt.

### Interrupt operation

When an interrupt is received, the contents of the program counter and processor status register are automatically stored into the stack. The interrupt disable flag is set to inhibit other interrupts from interfering. The corresponding interrupt request bit is cleared and the interrupt jump destination address is read from the vector table into the program counter.

### Notes on use

When the active edge of an external interrupt (INT0 to INT4, CNTR0, or CNTR1) is changed, the corresponding interrupt request bit may also be set. Therefore, please take following sequence;

- (1) Disable the external interrupt which is selected.
- (2) Change the active edge selection.
- (3) Clear the interrupt request bit which is selected to "0".
- (4) Enable the external interrupt which is selected.

**Table 9. Interrupt vector addresses and priority**

Interrupt Source	Priority	Vector Addresses (Note 1)		Interrupt Request Generating Conditions	Remarks
		High	Low		
Reset (Note 2)	1	FFFD <sub>16</sub>	FFFC <sub>16</sub>	At reset	Non-maskable
INT0	2	FFFB <sub>16</sub>	FFFA <sub>16</sub>	At detection of either rising or falling edge of INT0 input	External interrupt (active edge selectable)
INT1	3	FFF9 <sub>16</sub>	FFF8 <sub>16</sub>	At detection of either rising or falling edge of INT1 input	External interrupt (active edge selectable)
Serial I/O1 reception	4	FFF7 <sub>16</sub>	FFF6 <sub>16</sub>	At completion of serial I/O1 data reception	Valid when serial I/O1 is selected
Serial I/O1 transmission	5	FFF5 <sub>16</sub>	FFF4 <sub>16</sub>	At completion of serial I/O1 transfer shift or when transmission buffer is empty	Valid when serial I/O1 is selected
Timer X	6	FFF3 <sub>16</sub>	FFF2 <sub>16</sub>	At timer X underflow	
Timer Y	7	FFF1 <sub>16</sub>	FFF0 <sub>16</sub>	At timer Y underflow	
Timer 1	8	FFEF <sub>16</sub>	FFEE <sub>16</sub>	At timer 1 underflow	STP release timer underflow
Timer 2	9	FFED <sub>16</sub>	FFEC <sub>16</sub>	At timer 2 underflow	
CNTR0	10	FFE <sub>B</sub> <sub>16</sub>	FFE <sub>A</sub> <sub>16</sub>	At detection of either rising or falling edge of CNTR0 input	External interrupt (active edge selectable)
CNTR1	11	FFE <sub>9</sub> <sub>16</sub>	FFE <sub>8</sub> <sub>16</sub>	At detection of either rising or falling edge of CNTR1 input	External interrupt (active edge selectable)
Serial I/O2	12	FFE <sub>7</sub> <sub>16</sub>	FFE <sub>6</sub> <sub>16</sub>	At completion of serial I/O2 data transfer	Valid when serial I/O2 is selected
INT2	13	FFE <sub>5</sub> <sub>16</sub>	FFE <sub>4</sub> <sub>16</sub>	At detection of either rising or falling edge of INT2 input	External interrupt (active edge selectable)
INT3	14	FFE <sub>3</sub> <sub>16</sub>	FFE <sub>2</sub> <sub>16</sub>	At detection of either rising or falling edge of INT3 input	External interrupt (active edge selectable)
INT4	15	FFE <sub>1</sub> <sub>16</sub>	FFE <sub>0</sub> <sub>16</sub>	At detection of either rising or falling edge of INT4 input	External interrupt (active edge selectable)
A-D converter	16	FFD <sub>F</sub> <sub>16</sub>	FFD <sub>E</sub> <sub>16</sub>	At completion of A-D conversion	
BRK instruction	17	FFD <sub>D</sub> <sub>16</sub>	FFD <sub>C</sub> <sub>16</sub>	At BRK instruction execution	Non-maskable software interrupt

**Note 1:** Vector addresses contain interrupt jump destination addresses.

**2:** Reset function in the same way as an interrupt with the highest priority.

# HARDWARE

## FUNCTIONAL DESCRIPTION

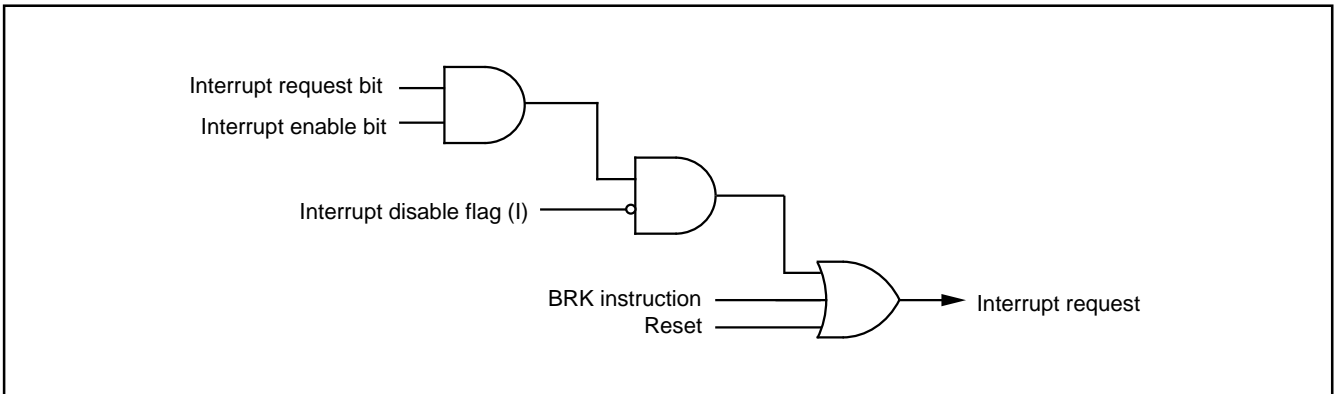

Fig. 15 Interrupt control

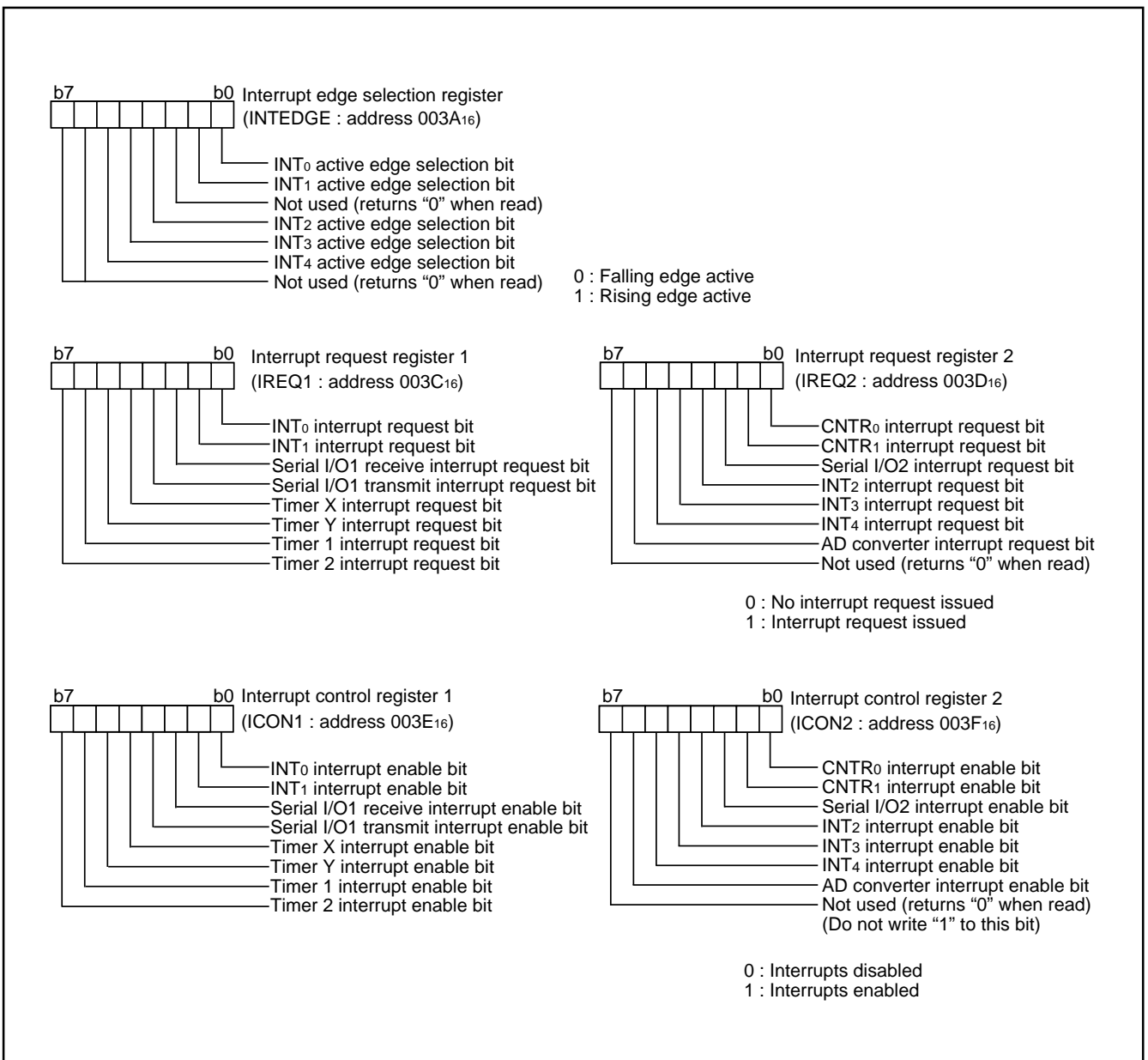

Fig. 16 Structure of interrupt-related registers

### Timers

The 3806 group has four timers: timer X, timer Y, timer 1, and timer 2.

All timers are count down. When the timer reaches “0016”, an underflow occurs at the next count pulse and the corresponding timer latch is reloaded into the timer and the count is continued. When a timer underflows, the interrupt request bit corresponding to that timer is set to “1”.

The division ratio of each timer or prescaler is given by  $1/(n + 1)$ , where n is the value in the corresponding timer or prescaler latch.

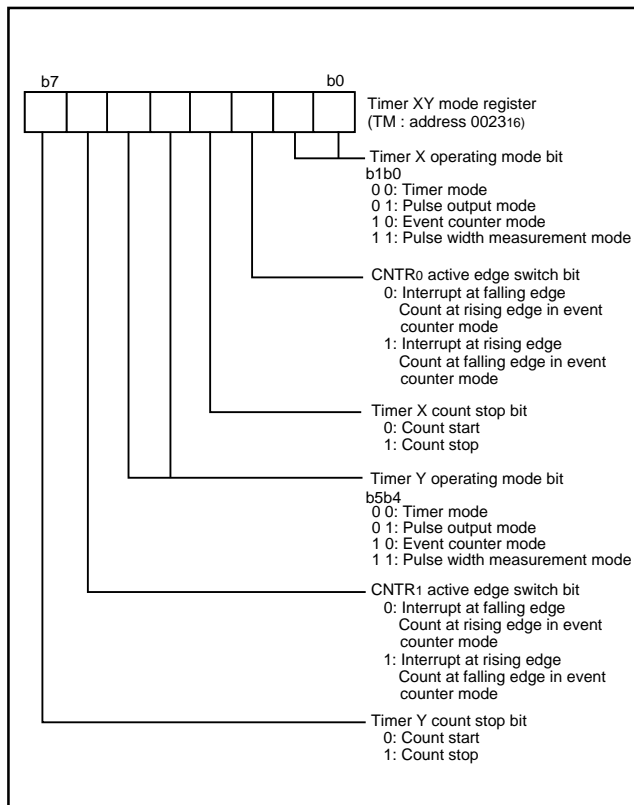

Fig. 17 Structure of timer XY register

### Timer 1 and Timer 2

The count source of prescaler 12 is the oscillation frequency divided by 16. The output of prescaler 12 is counted by timer 1 and timer 2, and a timer underflow sets the interrupt request bit.

### Timer X and Timer Y

Timer X and Timer Y can each be selected in one of four operating modes by setting the timer XY mode register.

#### Timer Mode

The timer counts  $f(X_{IN})/16$  in timer mode.

#### Pulse Output Mode

Timer X (or timer Y) counts  $f(X_{IN})/16$ . Whenever the contents of the timer reach “0016”, the signal output from the CNTR0 (or CNTR1) pin is inverted. If the CNTR0 (or CNTR1) active edge switch bit is “0”, output begins at “H”.

If it is “1”, output starts at “L”. When using a timer in this mode, set the corresponding port P54 (or port P55) direction register to output mode.

#### Event Counter Mode

Operation in event counter mode is the same as in timer mode, except the timer counts signals input through the CNTR0 or CNTR1 pin.

#### Pulse Width Measurement Mode

If the CNTR0 (or CNTR1) active edge selection bit is “0”, the timer counts at the oscillation frequency divided by 16 while the CNTR0 (or CNTR1) pin is at “H”. If the CNTR0 (or CNTR1) active edge switch bit is “1”, the count continues during the time that the CNTR0 (or CNTR1) pin is at “L”.

In all of these modes, the count can be stopped by setting the timer X (timer Y) count stop bit to “1”. Every time a timer underflows, the corresponding interrupt request bit is set.

# HARDWARE

## FUNCTIONAL DESCRIPTION

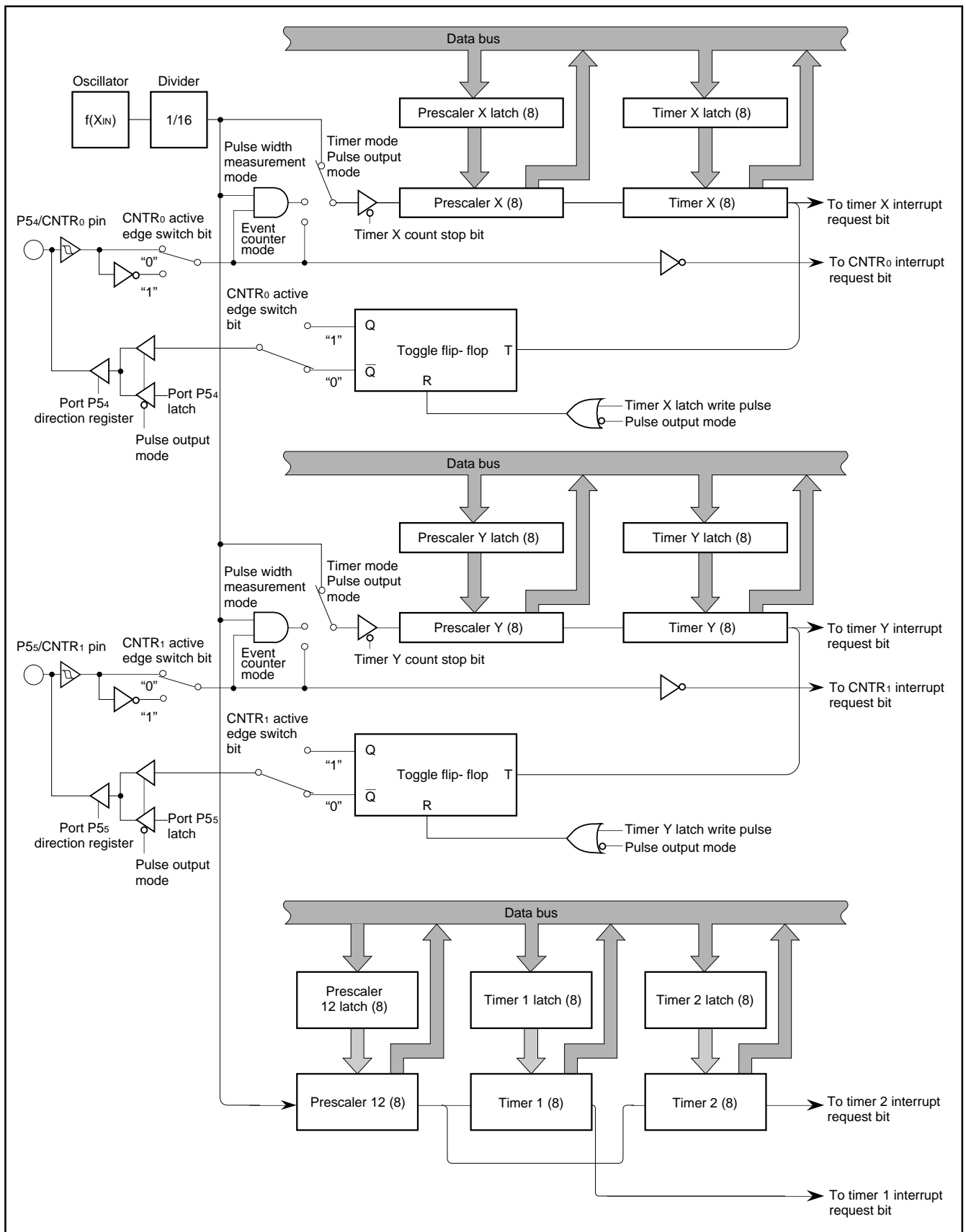

Fig. 18 Block diagram of timer X, timer Y, timer 1, and timer 2





# HARDWARE

## FUNCTIONAL DESCRIPTION

### Asynchronous serial I/O (UART) mode

Clock asynchronous serial I/O mode (UART) can be selected by clearing the serial I/O mode selection bit of the serial I/O control register to "0".

Eight serial data transfer formats can be selected, and the transfer formats used by a transmitter and receiver must be identical.

The transmit and receive shift registers each have a buffer, but the

two buffers have the same address in memory. Since the shift register cannot be written to or read from directly, transmit data is written to the transmit buffer, and receive data is read from the receive buffer.

The transmit buffer can also hold the next data to be transmitted, and the receive buffer can hold a character while the next character is being received.

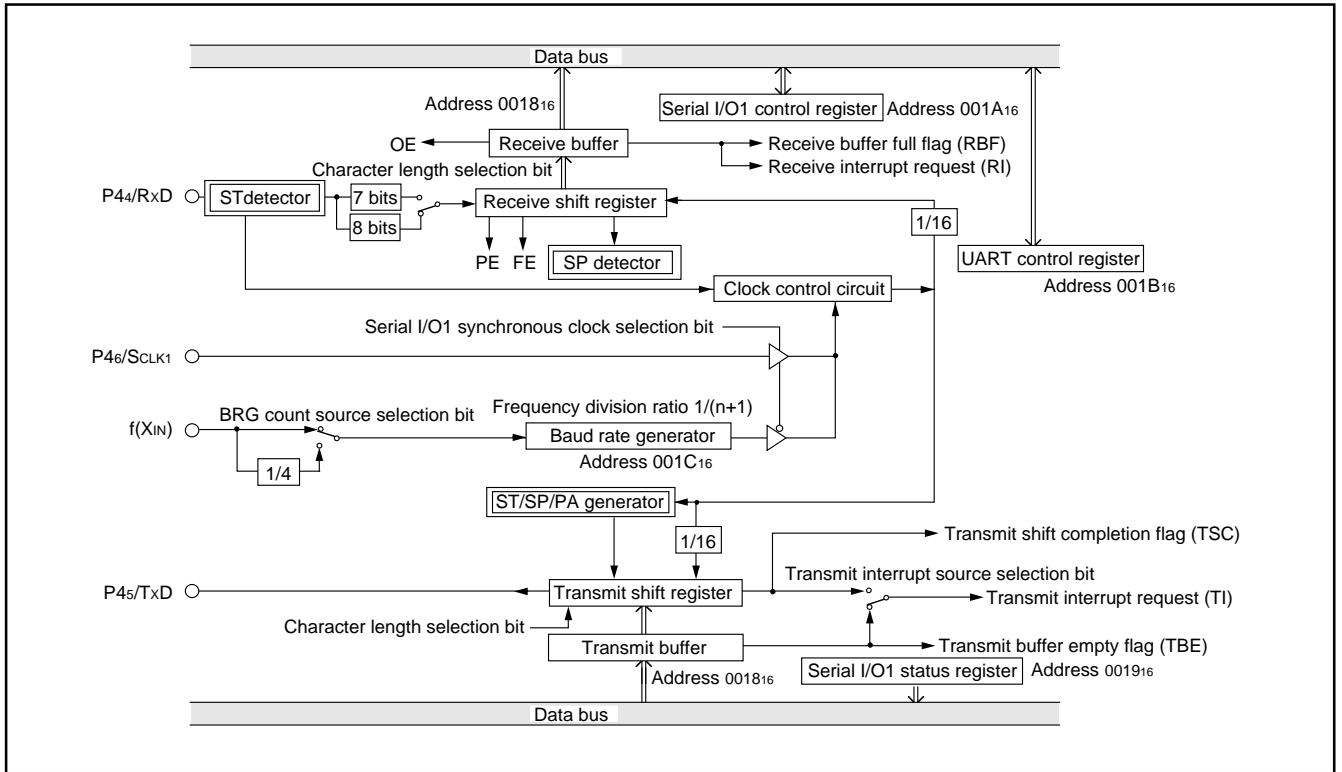

Fig. 21 Block diagram of UART serial I/O

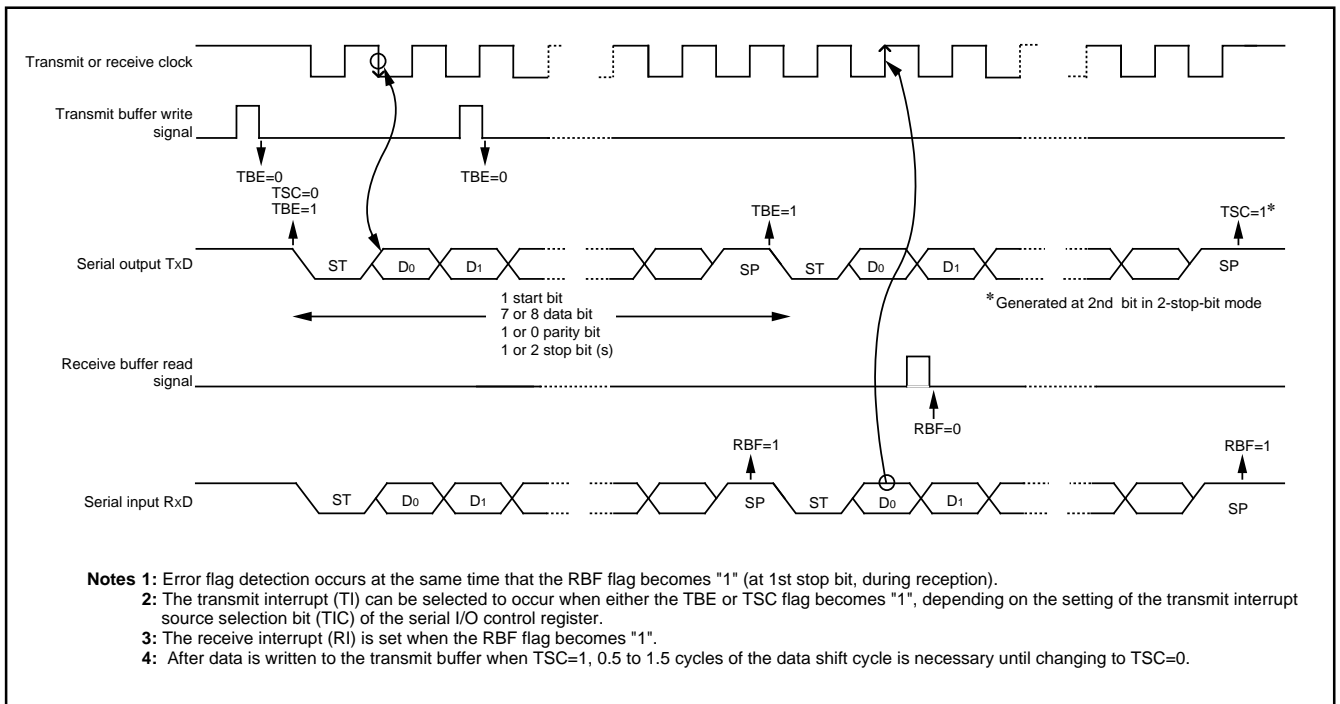

Fig. 22 Operation of UART serial I/O function

### Serial I/O1 control register (SIO1CON) 001A16

The serial I/O control register consists of eight control bits for the serial I/O function.

### UART control register (UARTCON) 001B16

The UART control register consists of four control bits (bits 0 to 3) which are valid when asynchronous serial I/O is selected and set the data format of an data transfer. One bit in this register (bit 4) is always valid and sets the output structure of the P45/TxD pin.

### Serial I/O1 status register (SIO1STS) 001916

The read-only serial I/O1 status register consists of seven flags (bits 0 to 6) which indicate the operating status of the serial I/O function and various errors.

Three of the flags (bits 4 to 6) are valid only in UART mode.

The receive buffer full flag (bit 1) is cleared to "0" when the receive buffer is read.

If there is an error, it is detected at the same time that data is transferred from the receive shift register to the receive buffer, and the receive buffer full flag is set. A write to the serial I/O status register clears all the error flags OE, PE, FE, and SE (bit 3 to bit 6, re-

spectively). Writing "0" to the serial I/O enable bit SIOE (bit 7 of the Serial I/O Control Register) also clears all the status flags, including the error flags.

All bits of the serial I/O1 status register are initialized to "0" at reset, but if the transmit enable bit (bit 4) of the serial I/O control register has been set to "1", the transmit shift completion flag (bit 2) and the transmit buffer empty flag (bit 0) become "1".

### Transmit buffer/Receive buffer register (TB/RB) 001816

The transmit buffer and the receive buffer are located at the same address. The transmit buffer is write-only and the receive buffer is read-only. If a character bit length is 7 bits, the MSB of data stored in the receive buffer is "0".

### Baud rate generator (BRG) 001C16

The baud rate generator determines the baud rate for serial transfer.

The baud rate generator divides the frequency of the count source by  $1/(n + 1)$ , where  $n$  is the value written to the baud rate generator.

# HARDWARE

## FUNCTIONAL DESCRIPTION

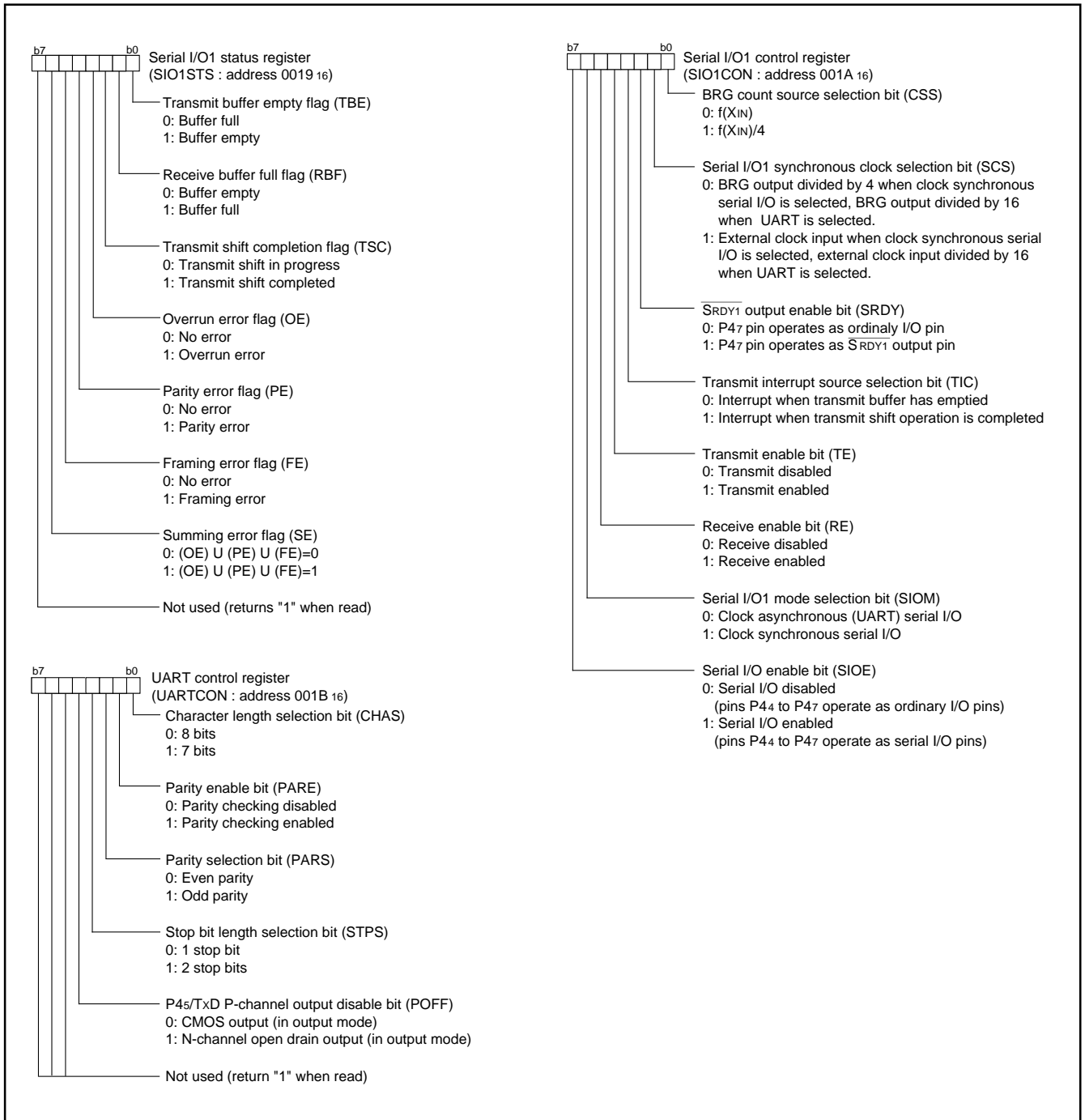

Fig. 23 Structure of serial I/O control registers

### Serial I/O2

The serial I/O2 function can be used only for clock synchronous serial I/O.

For clock synchronous serial I/O the transmitter and the receiver must use the same clock. If the internal clock is used, transfer is started by a write signal to the serial I/O2 register.

### Serial I/O2 control register (SIO2CON) 001D16

The serial I/O2 control register contains seven bits which control various serial I/O functions.

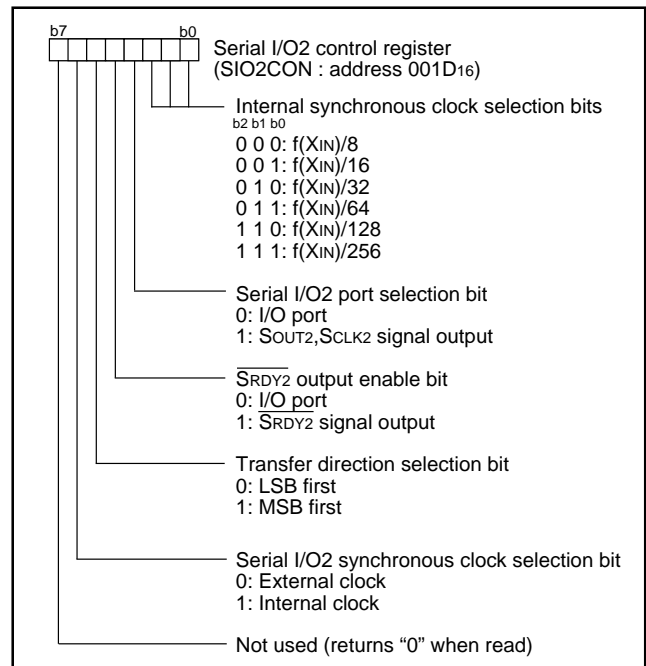

Fig. 24 Structure of serial I/O2 control register

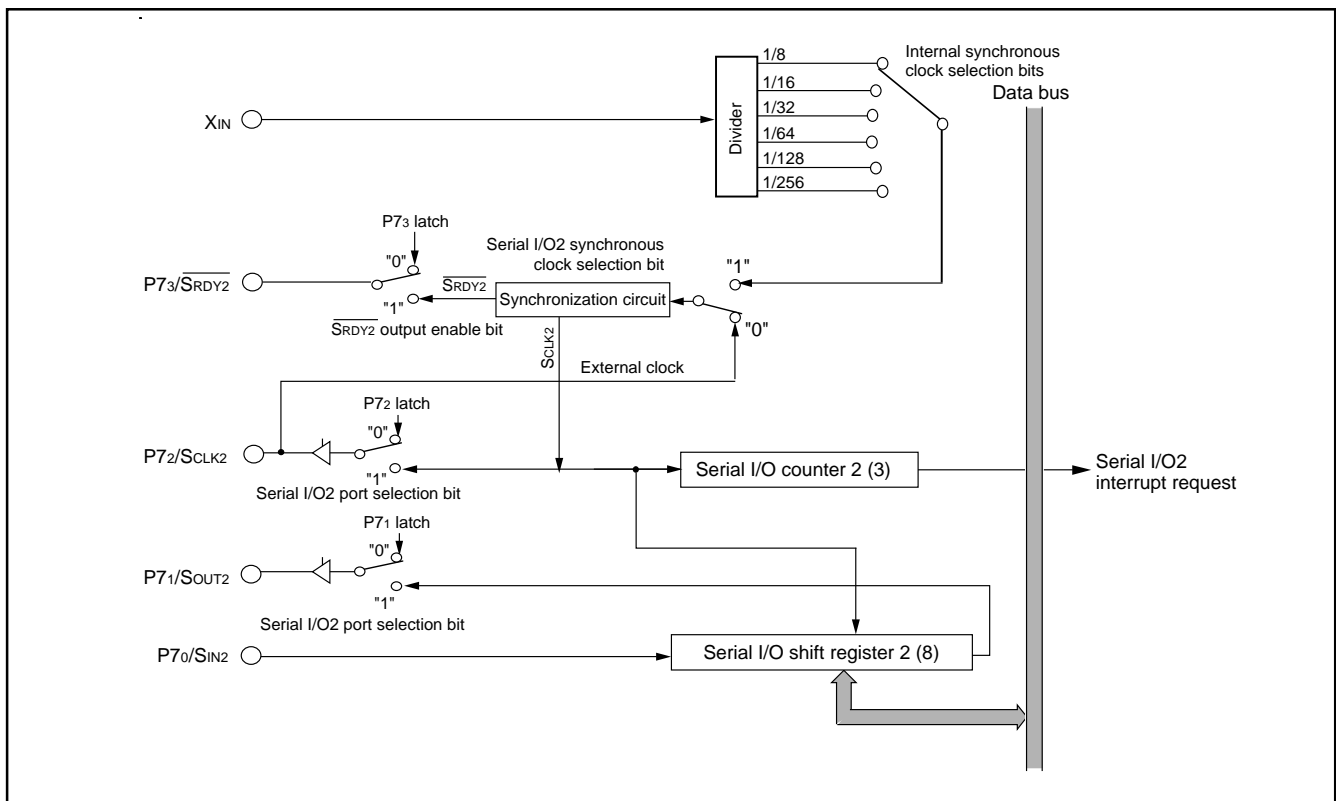

Fig. 25 Block diagram of serial I/O2 function

# HARDWARE

## FUNCTIONAL DESCRIPTION

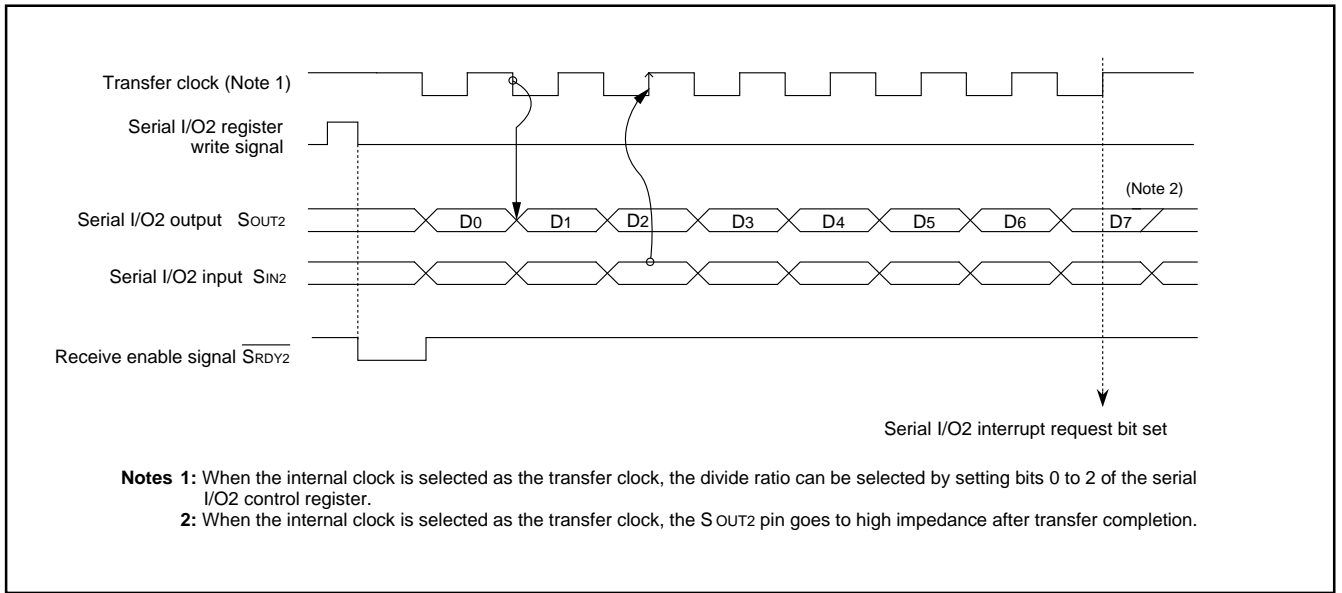

Fig. 26 Timing of serial I/O2 function

### A-D Converter

The functional blocks of the A-D converter are described below.

#### [A-D conversion register]

The A-D conversion register is a read-only register that stores the result of an A-D conversion. When reading this register during an A-D conversion, the previous conversion result is read.

#### [AD/DA control register]

The AD/DA control register controls the A-D conversion process. Bits 0 to 2 select a specific analog input pin. Bit 3 signals the completion of an A-D conversion. The value of this bit remains at "0" during an A-D conversion, and changes to "1" when an A-D conversion ends. Writing "0" to this bit starts the A-D conversion. Bits 6 and 7 are used to control the output of the D-A converter.

#### [Comparison voltage generator]

The comparison voltage generator divides the voltage between AVSS and VREF into 256, and outputs the divided voltages.

#### [Channel selector]

The channel selector selects one of the ports P60/AN0 to P67/AN7, and inputs the voltage to the comparator.

#### [Comparator and Control circuit]

The comparator and control circuit compares an analog input voltage with the comparison voltage, then stores the result in the A-D conversion register. When an A-D conversion is complete, the control circuit sets the AD conversion completion bit and the AD interrupt request bit to "1".

Note that the comparator is constructed linked to a capacitor, so set  $f(X_{IN})$  to 500 kHz or more during an A-D conversion.

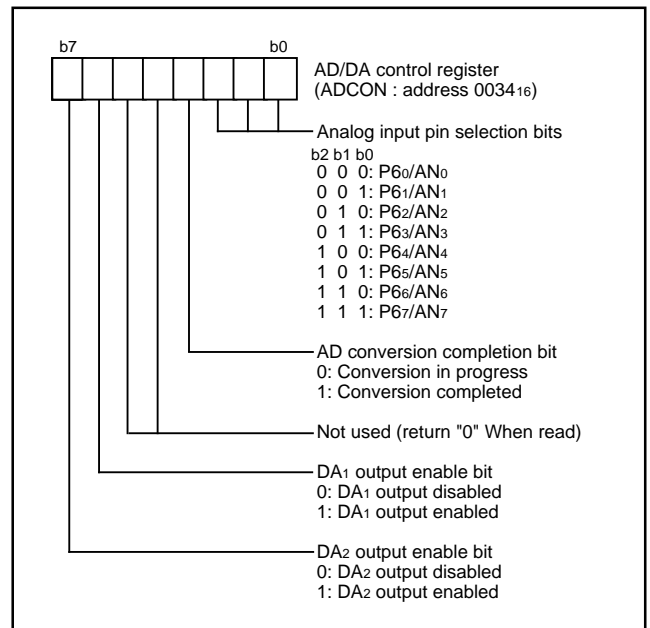

Fig. 27 Structure of AD/DA control register

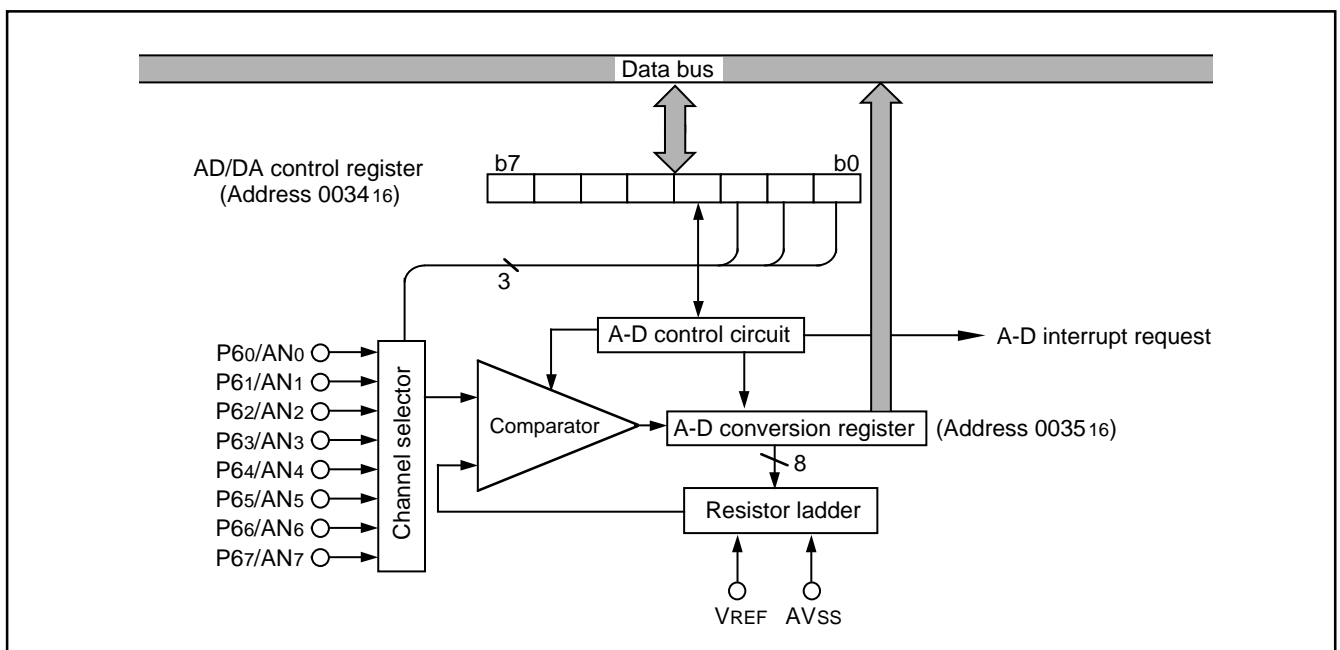

Fig. 28 Block diagram of A-D converter

# HARDWARE

## FUNCTIONAL DESCRIPTION

### D-A Converter

The 3806 group has two internal D-A converters (DA1 and DA2) with 8-bit resolutions.

The D-A converter is performed by setting the value in the D-A conversion register. The result of D-A converter is output from the DA1 or DA2 pin by setting the DA output enable bit to "1".

When using the D-A converter, the corresponding port direction register bit (DA1/P56 or DA2/P57) should be set to "0" (input status).

The output analog voltage  $V$  is determined by the value  $n$  (base 10) in the D-A conversion register as follows:

$$V = V_{REF} \times n / 256 \quad (n = 0 \text{ to } 255)$$

Where  $V_{REF}$  is the reference voltage.

At reset, the D-A conversion registers are cleared to "0016", the DA output enable bits are cleared to "0", and the P56/DA1 and P57/DA2 pins are set to input (high impedance).

The D-A output is not buffered, so connect an external buffer when driving a low-impedance load.

Set  $V_{CC}$  to 4.0 V or more when using the D-A converter.

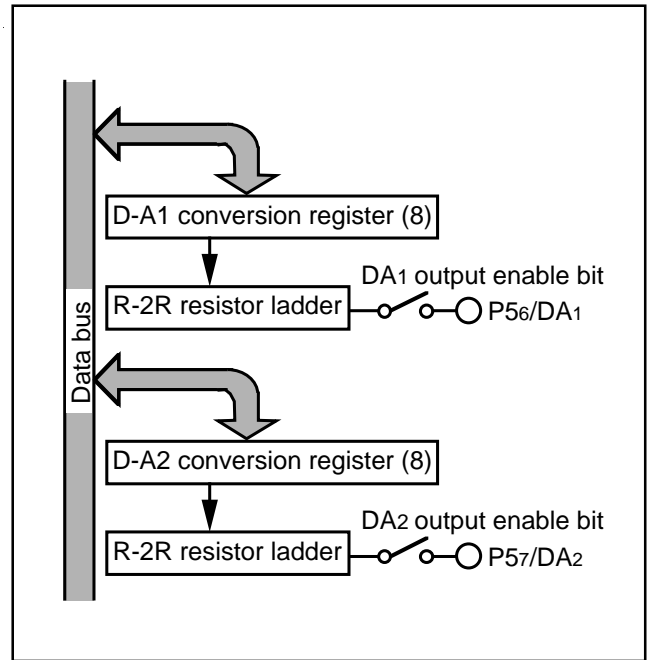

Fig. 29 Block diagram of D-A converter

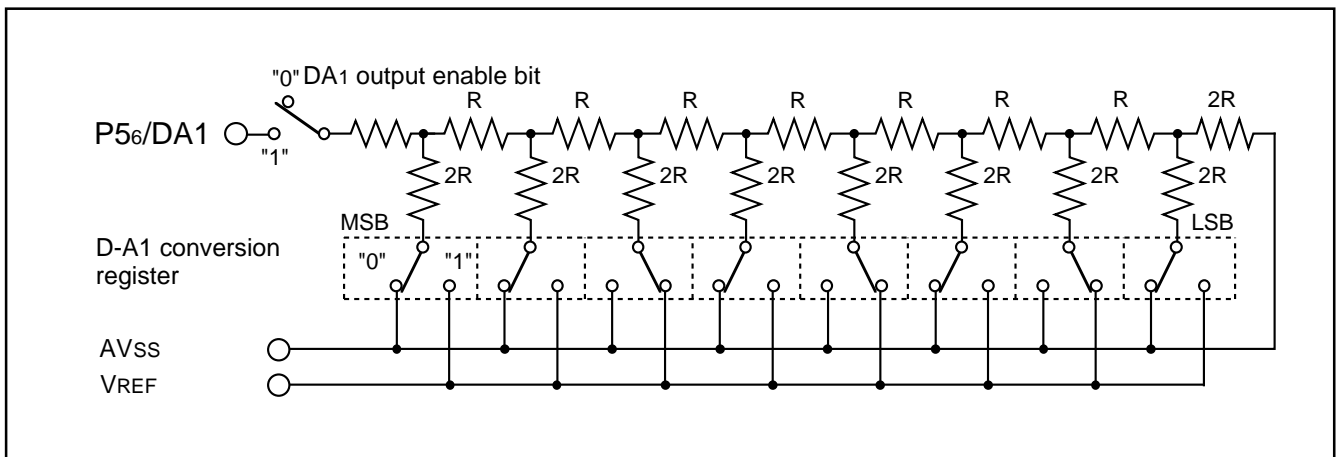

Fig. 30 Equivalent connection circuit of D-A converter

### Reset Circuit

To reset the microcomputer, the  $\overline{\text{RESET}}$  pin should be held at an "L" level for 2  $\mu\text{s}$  or more. Then the  $\overline{\text{RESET}}$  pin is returned to an "H" level (Note 1), reset is released. Internal operation does not begin until after 8 to 13  $X_{\text{IN}}$  clock cycles are completed. After the reset is completed, the program starts from the address contained in address  $\text{FFFD}_{16}$  (high-order byte) and address  $\text{FFFC}_{16}$  (low-order byte).

Make sure that the reset input voltage is less than 0.8 V for  $V_{\text{CC}}$  of 4.0 V (Note 2).

**Note 1.** The power source voltage should be between the following voltage.

- Between 3.0 V and 5.5 V for standard version
- Between 4.0 V and 5.5 V for extended operating temperature version
- Between 2.7 V and 5.5 V for high-speed version

**Note 2.** Reset input voltage is less than the following voltage.

- 0.6 V for  $V_{\text{CC}} = 3.0 \text{ V}$
- 0.8 V for  $V_{\text{CC}} = 4.0 \text{ V}$
- 0.54 V for  $V_{\text{CC}} = 2.7 \text{ V}$

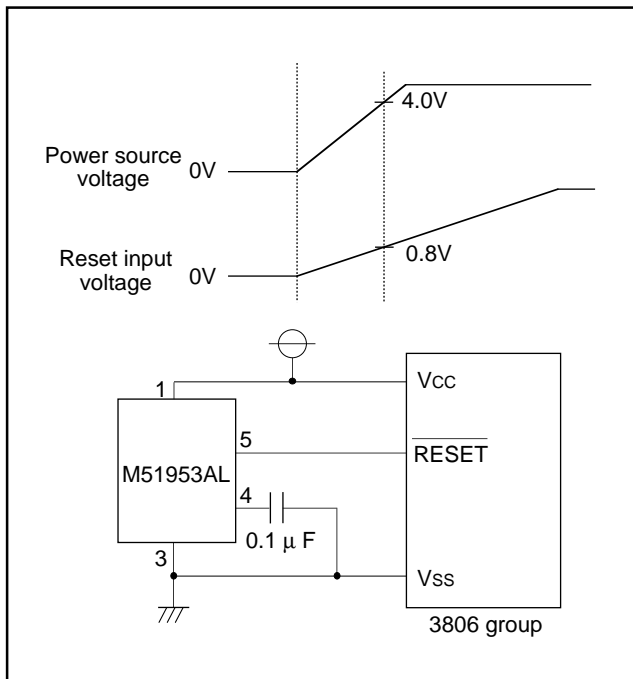

Fig. 31 Example of reset circuit

	Address	Register contents
(1) Port P0 direction register	(0001 <sub>16</sub> ) •••	00 <sub>16</sub>
(2) Port P1 direction register	(0003 <sub>16</sub> ) •••	00 <sub>16</sub>
(3) Port P2 direction register	(0005 <sub>16</sub> ) •••	00 <sub>16</sub>
(4) Port P3 direction register	(0007 <sub>16</sub> ) •••	00 <sub>16</sub>
(5) Port P4 direction register	(0009 <sub>16</sub> ) •••	00 <sub>16</sub>
(6) Port P5 direction register	(000B <sub>16</sub> ) •••	00 <sub>16</sub>
(7) Port P6 direction register	(000D <sub>16</sub> ) •••	00 <sub>16</sub>
(8) Port P7 direction register	(000F <sub>16</sub> ) •••	00 <sub>16</sub>
(9) Port P8 direction register	(0011 <sub>16</sub> ) •••	00 <sub>16</sub>
(10) Serial I/O1 status register	(0019 <sub>16</sub> ) •••	1 0 0 0 0 0 0 0
(11) Serial I/O1 control register	(001A <sub>16</sub> ) •••	00 <sub>16</sub>
(12) UART control register	(001B <sub>16</sub> ) •••	1 1 1 0 0 0 0 0
(13) Serial I/O2 control register	(001D <sub>16</sub> ) •••	00 <sub>16</sub>
(14) Prescaler 12	(0020 <sub>16</sub> ) •••	FF <sub>16</sub>
(15) Timer 1	(0021 <sub>16</sub> ) •••	01 <sub>16</sub>
(16) Timer 2	(0022 <sub>16</sub> ) •••	FF <sub>16</sub>
(17) Timer XY mode register	(0023 <sub>16</sub> ) •••	00 <sub>16</sub>
(18) Prescaler X	(0024 <sub>16</sub> ) •••	FF <sub>16</sub>
(19) Timer X	(0025 <sub>16</sub> ) •••	FF <sub>16</sub>
(20) Prescaler Y	(0026 <sub>16</sub> ) •••	FF <sub>16</sub>
(21) Timer Y	(0027 <sub>16</sub> ) •••	FF <sub>16</sub>
(22) AD/DA control register	(0034 <sub>16</sub> ) •••	0 0 0 0 0 1 0 0
(23) D-A1 conversion register	(0036 <sub>16</sub> ) •••	00 <sub>16</sub>
(24) D-A2 conversion register	(0037 <sub>16</sub> ) •••	00 <sub>16</sub>
(25) Interrupt edge selection register	(003A <sub>16</sub> ) •••	00 <sub>16</sub>
(26) CPU mode register	(003B <sub>16</sub> ) •••	0 0 0 0 0 0 0 *
(27) Interrupt request register 1	(003C <sub>16</sub> ) •••	00 <sub>16</sub>
(28) Interrupt request register 2	(003D <sub>16</sub> ) •••	00 <sub>16</sub>
(29) Interrupt control register 1	(003E <sub>16</sub> ) •••	00 <sub>16</sub>
(30) Interrupt control register 2	(003F <sub>16</sub> ) •••	00 <sub>16</sub>
(31) Processor status register	(PS)	x x x x x 1 x x
(32) Program counter	(PC <sub>H</sub> )	Contents of address $\text{FFFD}_{16}$
	(PC <sub>L</sub> )	Contents of address $\text{FFFC}_{16}$

Note. x : Undefined

\* : The initial values of  $\text{CM}_i$  are determined by the level at the  $\text{CNV}_{\text{SS}}$  pin.

The contents of all other registers and RAM are undefined after a reset, so they must be initialized by software.

Fig. 32 Internal status of microcomputer after reset



# HARDWARE

## FUNCTIONAL DESCRIPTION

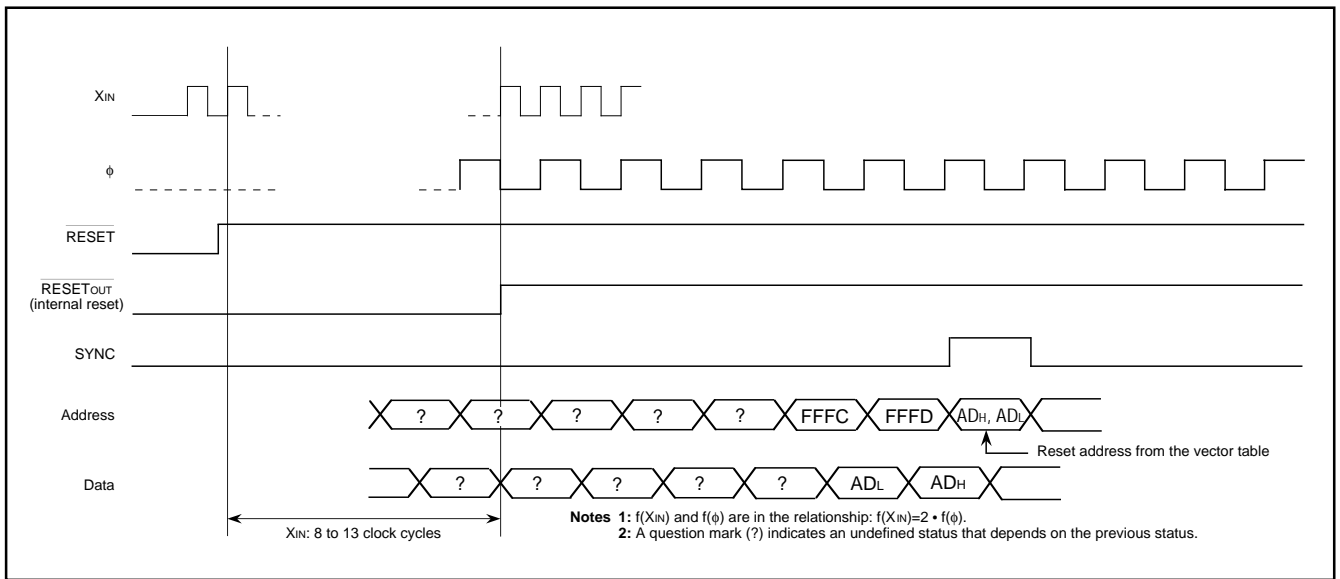

Fig. 33 Timing of reset

### Clock Generating Circuit

An oscillation circuit can be formed by connecting a resonator between XIN and XOUT. To supply a clock signal externally, input it to the XIN pin and make the XOUT pin open.

### Oscillation control

#### Stop Mode

If the STP instruction is executed, the internal clock  $\phi$  stops at an "H". Timer 1 is set to "0116" and prescaler 12 is set to "FF16". Oscillator restarts when an external interrupt is received, but the internal clock  $\phi$  remains at an "H" until timer 1 underflow. This allows time for the clock circuit oscillation to stabilize. If oscillator is restarted by a reset, no wait time is generated, so keep the RESET pin at an "L" level until oscillation has stabilized.

#### Wait Mode

If the WIT instruction is executed, the internal clock  $\phi$  stops at an "H" level, but the oscillator itself does not stop. The internal clock restarts if a reset occurs or when an interrupt is received. Since the oscillator does not stop, normal operation can be started immediately after the clock is restarted. To ensure that interrupts will be received to release the STP or WIT state, interrupt enable bits must be set to "1" before the STP or WIT instruction is executed.

When the STP status is released, prescaler 12 and timer 1 will start counting and reset will not be released until timer 1 underflows, so set the timer 1 interrupt enable bit to "0" before the STP instruction is executed.

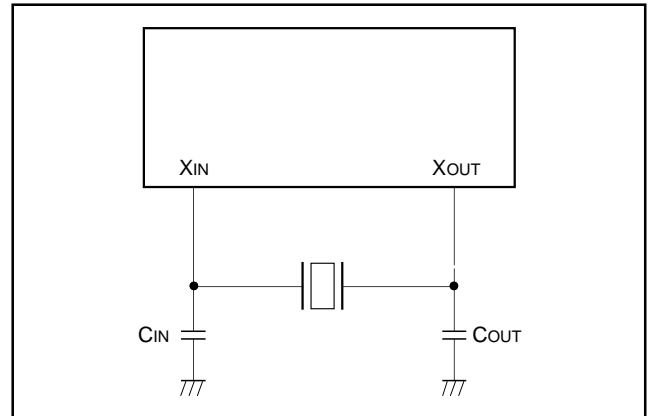

Fig. 34 Ceramic resonator circuit

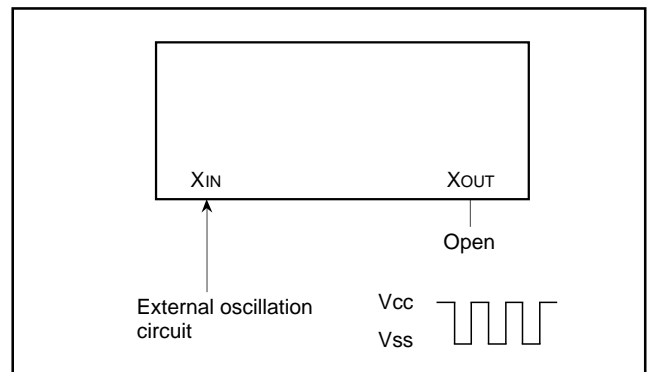

Fig. 35 External clock input circuit

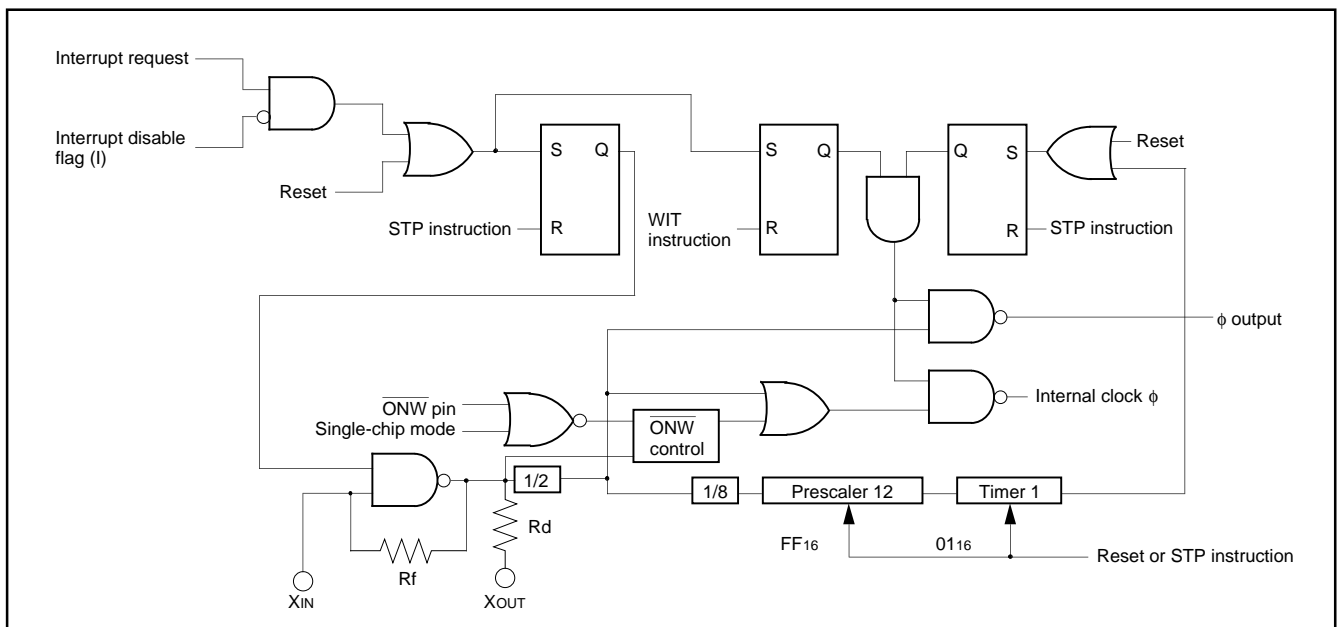

Fig. 36 Block diagram of clock generating circuit

# HARDWARE

## FUNCTIONAL DESCRIPTION

### Processor Modes

Single-chip mode, memory expansion mode, and microprocessor mode can be selected by changing the contents of the processor mode bits CM0 and CM1 (bits 0 and 1 of address 003B<sub>16</sub>). In memory expansion mode and microprocessor mode, memory can be expanded externally through ports P0 to P3. In these modes, ports P0 to P3 lose their I/O port functions and become bus pins.

**Table 10. Functions of ports in memory expansion mode and microprocessor mode**

Port Name	Function
Port P0	Outputs low-order byte of address.
Port P1	Outputs high-order byte of address.
Port P2	Operates as I/O pins for data D7 to D0 (including instruction codes).
Port P3	P30 and P31 function only as output pins (except that the port latch cannot be read). P32 is the ONW input pin. P33 is the RESETOUT output pin. (Note) P34 is the $\phi$ output pin. P35 is the SYNC output pin. P36 is the WR output pin, and P37 is the RD output pin.

**Note:** If CNVss is connected to Vss, the microcomputer goes to single-chip mode after a reset, so this pin cannot be used as the RESETOUT output pin.

### Single-Chip Mode

Select this mode by resetting the microcomputer with CNVss connected to Vss.

### Memory Expansion Mode

Select this mode by setting the processor mode bits to "01" in software with CNVss connected to Vss. This mode enables external memory expansion while maintaining the validity of the internal ROM. Internal ROM will take precedence over external memory if addresses conflict.

### Microprocessor Mode

Select this mode by resetting the microcomputer with CNVss connected to Vcc, or by setting the processor mode bits to "10" in software with CNVss connected to Vss. In microprocessor mode, the internal ROM is no longer valid and external memory must be used.

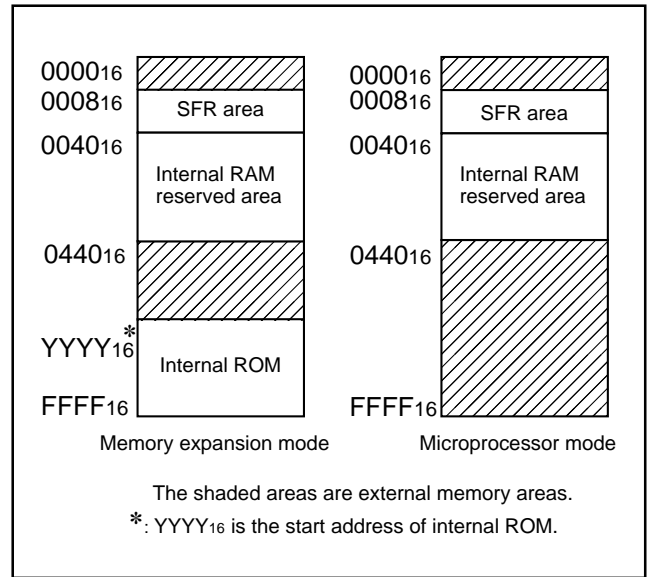

**Fig. 37 Memory maps in various processor modes**

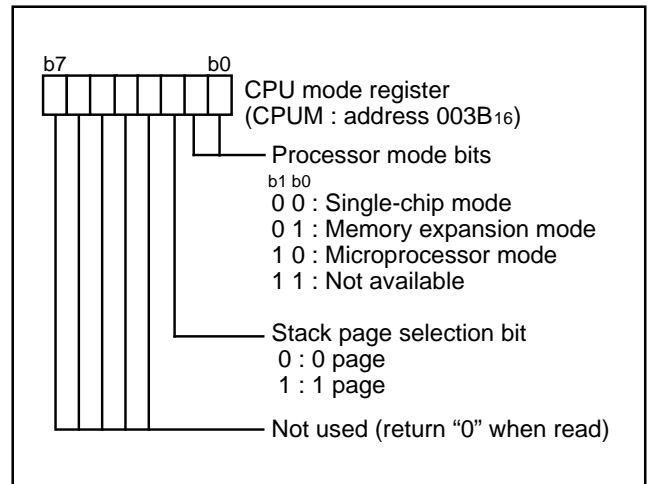

**Fig. 38 Structure of CPU mode register**

### Bus control with memory expansion

The 3806 group has a built-in  $\overline{ONW}$  function to facilitate access to external memory and I/O devices in memory expansion mode or microprocessor mode.

If an "L" level signal is input to the  $\overline{ONW}$  pin when the CPU is in a read or write state, the corresponding read or write cycle is extended by one cycle of  $\phi$ . During this extended period, the  $\overline{RD}$  or  $\overline{WR}$  signal remains at "L". This extension period is valid only for writing to and reading from addresses 0000<sub>16</sub> to 0007<sub>16</sub> and 0440<sub>16</sub> to FFFF<sub>16</sub> in microprocessor mode, 0440<sub>16</sub> to YYYYY<sub>16</sub> in memory expansion mode, and only read and write cycles are extended.

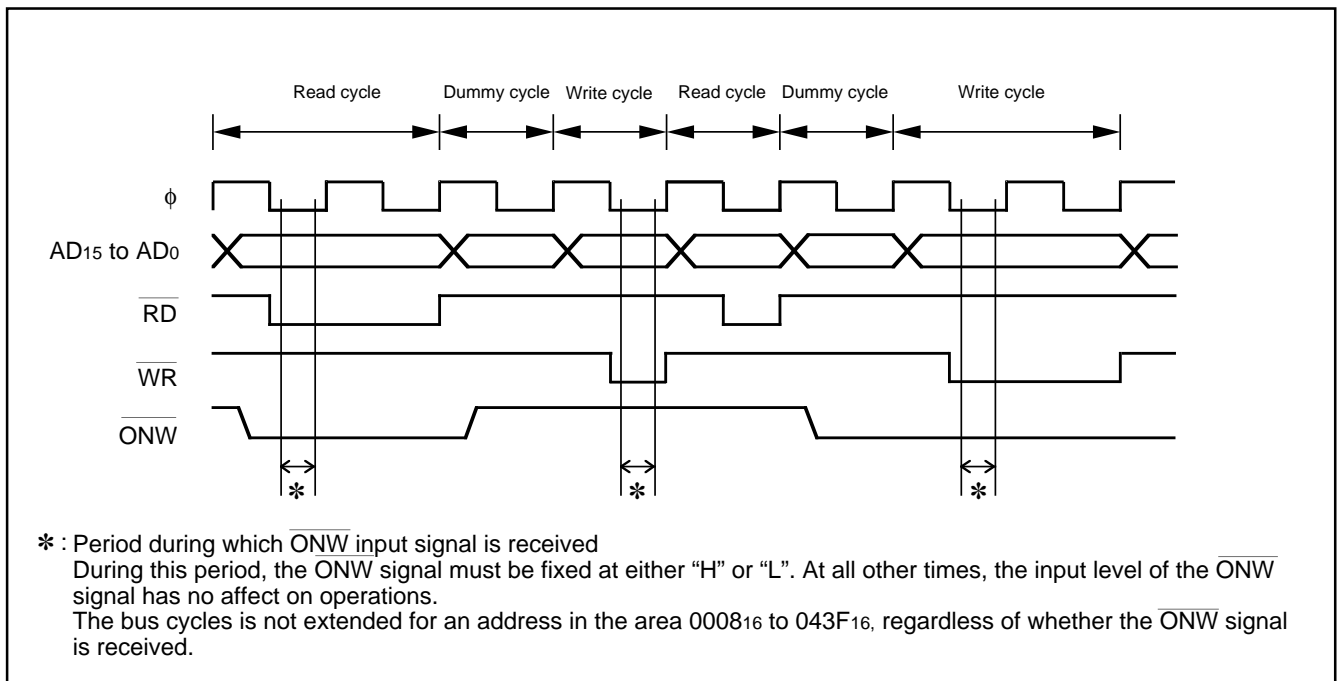

Fig. 39  $\overline{ONW}$  function timing

# HARDWARE

## NOTES ON PROGRAMMING

---

### NOTES ON PROGRAMMING Processor Status Register

The contents of the processor status register (PS) after a reset are undefined, except for the interrupt disable flag (I) which is "1". After a reset, initialize flags which affect program execution.

In particular, it is essential to initialize the index X mode (T) and the decimal mode (D) flags because of their effect on calculations.

### Interrupts

The contents of the interrupt request bits do not change immediately after they have been written. After writing to an interrupt request register, execute at least one instruction before executing a BBC or BBS instruction.

### Decimal Calculations

To calculate in decimal notation, set the decimal mode flag (D) to "1", then execute an ADC or SBC instruction. Only the ADC and SBC instructions yield proper decimal results. After executing an ADC or SBC instruction, execute at least one instruction before executing a SEC, CLC, or CLD instruction.

In decimal mode, the values of the negative (N), overflow (V), and zero (Z) flags are invalid.

The carry flag can be used to indicate whether a carry or borrow has occurred. Initialize the carry flag before each calculation. Clear the carry flag before an ADC and set the flag before an SBC.

### Timers

If a value  $n$  (between 0 and 255) is written to a timer latch, the frequency division ratio is  $1/(n + 1)$ .

### Multiplication and Division Instructions

The index X mode (T) and the decimal mode (D) flags do not affect the MUL and DIV instruction.

The execution of these instructions does not change the contents of the processor status register.

### Ports

The contents of the port direction registers cannot be read.

The following cannot be used:

- The data transfer instruction (LDA, etc.)
- The operation instruction when the index X mode flag (T) is "1"
- The addressing mode which uses the value of a direction register as an index
- The bit-test instruction (BBC or BBS, etc.) to a direction register
- The read-modify-write instruction (ROR, CLB, or SEB, etc.) to a direction register

Use instructions such as LDM and STA, etc., to set the port direction registers.

### Serial I/O

In clock synchronous serial I/O, if the receive side is using an external clock and it is to output the  $\overline{\text{SRDY1}}$  signal, set the transmit enable bit, the receive enable bit, and the  $\overline{\text{SRDY1}}$  output enable bit to "1".

Serial I/O1 continues to output the final bit from the TXD pin after transmission is completed. The SOUT2 pin from serial I/O2 goes to high impedance after transmission is completed.

### A-D Converter

The comparator uses internal capacitors whose charge will be lost if the clock frequency is too low.

Make sure that  $f(\text{XIN})$  is at least 500 kHz during an A-D conversion. (If the  $\overline{\text{ONW}}$  pin has been set to "L", the A-D conversion will take twice as long to match the longer bus cycle, and so  $f(\text{XIN})$  must be at least 1 MHz.)

Do not execute the STP or WIT instruction during an A-D conversion.

### D-A Converter

The accuracy of the D-A converter becomes poor rapidly under the  $V_{CC} = 4.0$  V or less condition.

### Instruction Execution Time

The instruction execution time is obtained by multiplying the frequency of the internal clock  $\phi$  by the number of cycles needed to execute an instruction.

The number of cycles required to execute an instruction is shown in the list of machine instructions.

The frequency of the internal clock  $\phi$  is half of the  $\text{XIN}$  frequency. When the  $\overline{\text{ONW}}$  function is used in modes other than single-chip mode, the frequency of the internal clock  $\phi$  may be one fourth the  $\text{XIN}$  frequency.

### Memory Expansion Mode and Microprocessor Mode

Execute the LDM or STA instruction for writing to port P3 (address 000616) in memory expansion mode and microprocessor mode.

Set areas which can be read out and write to port P3 (address 000616) in a memory, using the read-modify-write instruction (SEB, CLB).

## DATA REQUIRED FOR MASK ORDERS/ROM PROGRAMMING METHOD

### DATA REQUIRED FOR MASK ORDERS

The following are necessary when ordering a mask ROM production:

1. Mask ROM Order Confirmation Form
2. Mask Specification Form
3. Data to be written to ROM, in EPROM form (three identical copies)

### ROM PROGRAMMING METHOD

The built-in PROM of the blank One Time PROM version and built-in EPROM version can be read or programmed with a general-purpose PROM programmer using a special programming adapter. Set the address of PROM programmer in the user ROM area.

**Table 11. Programming adapter**

Package	Name of Programming Adapter
80P6N-A	PCA4738F-80A
80P6S-A	PCA4738G-80A
80D0	PCA4738L-80A

The PROM of the blank One Time PROM version is not tested or screened in the assembly process and following processes. To ensure proper operation after programming, the procedure shown in Figure 40 is recommended to verify programming.

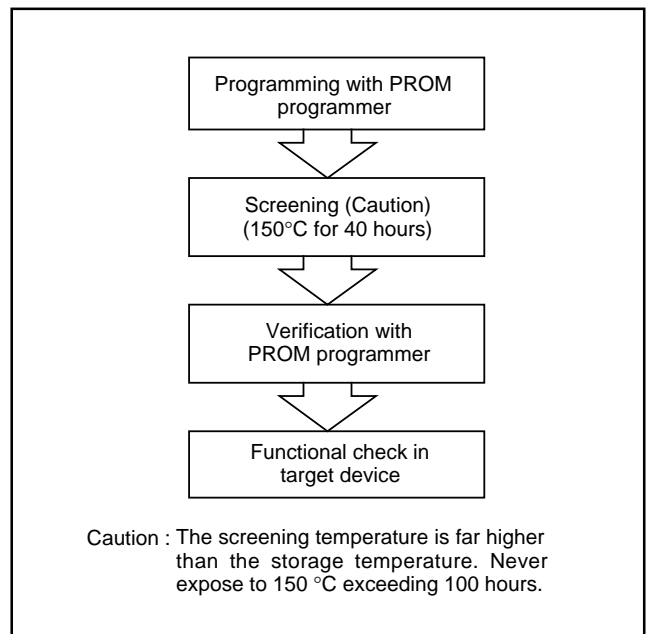

**Fig. 40 Programming and testing of One Time PROM version**

# HARDWARE

## FUNCTIONAL DESCRIPTION SUPPLEMENT

### FUNCTIONAL DESCRIPTION SUPPLEMENT

#### Interrupt

3806 group permits interrupts on the basis of 16 sources. It is vector interrupts with a fixed priority system. Accordingly, when two or more interrupt

requests occur during the same sampling, the higher-priority interrupt is accepted first. This priority is determined by hardware, but variety of priority processing can be performed by software, using an interrupt enable bit and an interrupt disable flag. For interrupt sources, vector addresses and interrupt priority, refer to “Table 12.”

**Table 12. Interrupt sources, vector addresses and interrupt priority**

Priority	Interrupt sources	Vector addresses		Remarks
		High-order	Low-order	
1	Reset (Note)	FFFD <sub>16</sub>	FFFC <sub>16</sub>	Non-maskable
2	INT <sub>0</sub> interrupt	FFFB <sub>16</sub>	FFFA <sub>16</sub>	External interrupt (active edge selectable)
3	INT <sub>1</sub> interrupt	FFF9 <sub>16</sub>	FFF8 <sub>16</sub>	External interrupt (active edge selectable)
4	Serial I/O1 receive interrupt	FFF7 <sub>16</sub>	FFF6 <sub>16</sub>	Valid when serial I/O1 is selected
5	Serial I/O1 transmit interrupt	FFF5 <sub>16</sub>	FFF4 <sub>16</sub>	Valid when serial I/O1 is selected
6	Timer X interrupt	FFF3 <sub>16</sub>	FFF2 <sub>16</sub>	
7	Timer Y interrupt	FFF1 <sub>16</sub>	FFF0 <sub>16</sub>	
8	Timer 1 interrupt	FFEF <sub>16</sub>	FFEE <sub>16</sub>	STP release timer underflow
9	Timer 2 interrupt	FFED <sub>16</sub>	FFEC <sub>16</sub>	
10	CNTR <sub>0</sub> interrupt	FFEB <sub>16</sub>	FFEA <sub>16</sub>	External interrupt (active edge selectable)
11	CNTR <sub>1</sub> interrupt	FFE9 <sub>16</sub>	FFE8 <sub>16</sub>	External interrupt (active edge selectable)
12	Serial I/O2 interrupt	FFE7 <sub>16</sub>	FFE6 <sub>16</sub>	Valid when serial I/O2 is selected
13	INT <sub>2</sub> interrupt	FFE5 <sub>16</sub>	FFE4 <sub>16</sub>	External interrupt (active edge selectable)
14	INT <sub>3</sub> interrupt	FFE3 <sub>16</sub>	FFE2 <sub>16</sub>	External interrupt (active edge selectable)
15	INT <sub>4</sub> interrupt	FFE1 <sub>16</sub>	FFE0 <sub>16</sub>	External interrupt (active edge selectable)
16	A-D conversion interrupt	FFDF <sub>16</sub>	FFDE <sub>16</sub>	
17	BRK instruction interrupt	FFDD <sub>16</sub>	FFDC <sub>16</sub>	Non-maskable software interrupt

**Note:** Reset functions in the same way as an interrupt with the highest priority.

**Timing After Interrupt**

The interrupt processing routine begins with the machine cycle following the completion of the instruction that is currently in execution.

Figure 41 shows a timing chart after an interrupt occurs, and Figure 42 shows the time up to execution of the interrupt processing routine.

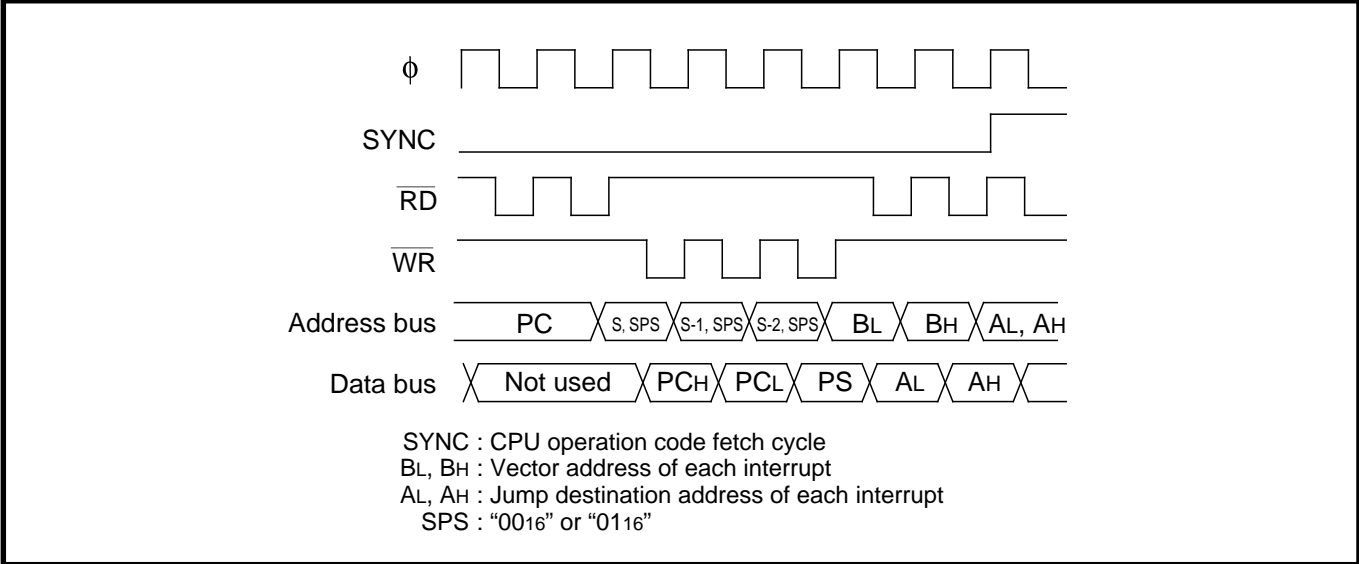

**Fig. 41 Timing chart after an interrupt occurs**

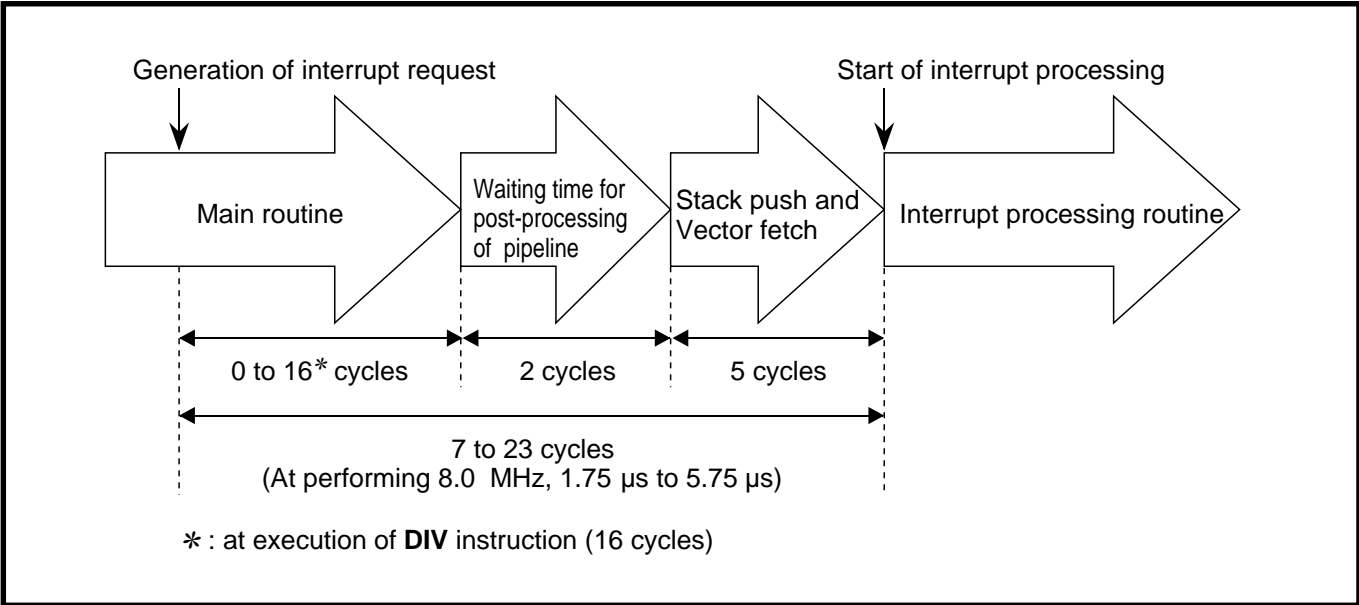

**Fig. 42 Time up to execution of the interrupt processing routine**



# HARDWARE

## FUNCTIONAL DESCRIPTION SUPPLEMENT

### A-D Converter

A-D conversion is started by setting AD conversion completion bit to "0." During A-D conversion, internal operations are performed as follows.

1. After the start of A-D conversion, A-D conversion register goes to "0016."
2. The highest-order bit of A-D conversion register is set to "1," and the comparison voltage Vref is input to the comparator. Then, Vref is compared with analog input voltage VIN.
3. As a result of comparison, when Vref < VIN, the highest-order bit of A-D conversion register becomes "1." When Vref > VIN, the highest-order bit becomes "0."

By repeating the above operations up to the lowest-order bit of the A-D conversion register, an analog value converts into a digital value.

A-D conversion completes at 50 clock cycles (12.5 μs at f(XIN) = 8.0 MHz) after it is started, and the result of the conversion is stored into the A-D conversion register.

Concurrently with the completion of A-D conversion, A-D conversion interrupt request occurs, so that the AD conversion interrupt request bit is set to "1."

**Relative formula for a reference voltage VREF of A-D converter and Vref**

When n = 0                      Vref = 0

When n = 1 to 255            Vref =  $\frac{V_{REF}}{256} \times (n - 0.5)$

n : the value of A-D converter (decimal numeral)

**Table 13. Change of A-D conversion register during A-D conversion**

	Change of A-D conversion register	Value of comparison voltage (Vref)
At start of conversion	0 0 0 0 0 0 0 0	0
First comparison	1 0 0 0 0 0 0 0	$\frac{V_{REF}}{2} - \frac{V_{REF}}{512}$
Second comparison	*1 1 0 0 0 0 0 0	$\frac{V_{REF}}{2} \pm \frac{V_{REF}}{4} - \frac{V_{REF}}{512}$
Third comparison	*1 *2 1 0 0 0 0 0	$\frac{V_{REF}}{2} \pm \frac{V_{REF}}{4} \pm \frac{V_{REF}}{8} - \frac{V_{REF}}{512}$
~	~	~
After completion of eighth comparison	A result of A-D conversion *1 *2 *3 *4 *5 *6 *7 *8	

\*1: A result of the first comparison

\*3: A result of the third comparison

\*5: A result of the fifth comparison

\*7: A result of the seventh comparison

\*2: A result of the second comparison

\*4: A result of the fourth comparison

\*6: A result of the sixth comparison

\*8: A result of the eighth comparison

Figure 43 shows A-D conversion equivalent circuit, and Figure 44 shows A-D conversion timing chart.

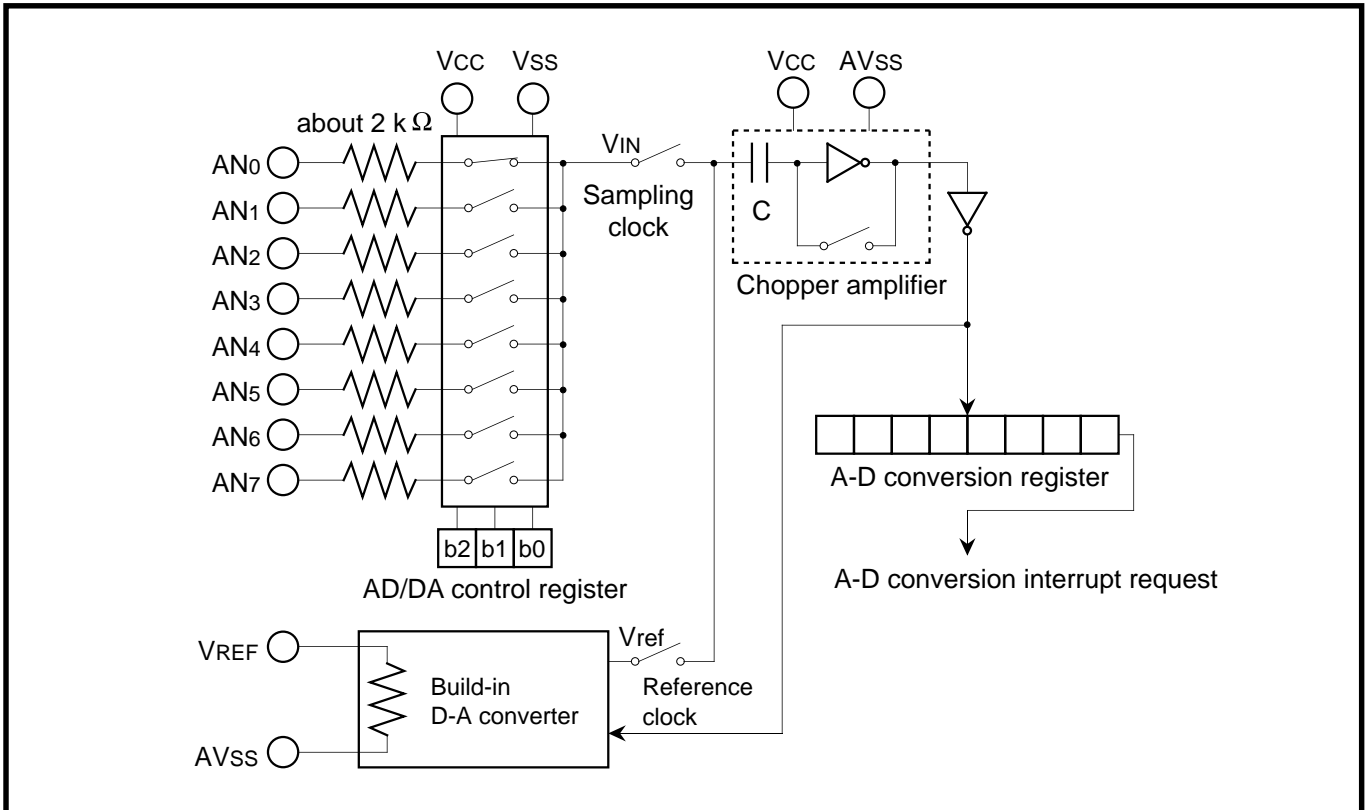

**Fig. 43 A-D conversion equivalent circuit**

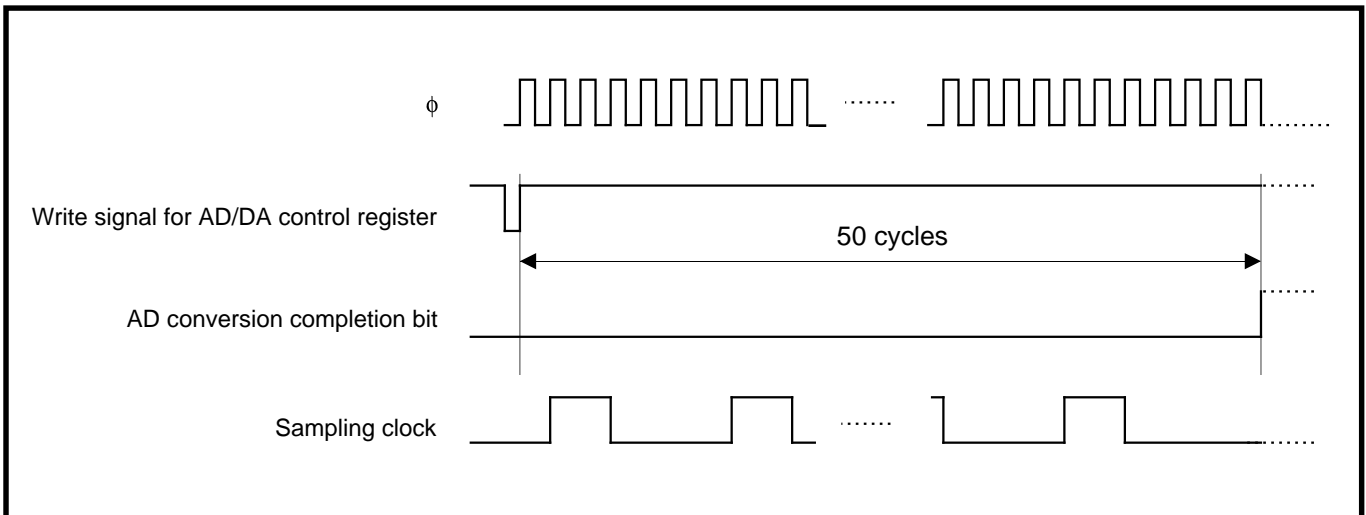

**Fig. 44 A-D conversion timing chart**

# **HARDWARE**

## **FUNCTIONAL DESCRIPTION SUPPLEMENT**

---

### ***MEMORANDUM***



# CHAPTER 2

## **APPLICATION**

- 2.1 I/O port
- 2.2 Timer
- 2.3 Serial I/O
- 2.4 A-D converter
- 2.5 Processor mode
- 2.6 Reset

# APPLICATION

## 2.1 I/O port

### 2.1 I/O port

#### 2.1.1 Memory map of I/O port

0000 <sub>16</sub>	Port P0 (P0)
0001 <sub>16</sub>	Port P0 direction register (P0D)
0002 <sub>16</sub>	Port P1 (P1)
0003 <sub>16</sub>	Port P1 direction register (P1D)
0004 <sub>16</sub>	Port P2 (P2)
0005 <sub>16</sub>	Port P2 direction register (P2D)
0006 <sub>16</sub>	Port P3 (P3)
0007 <sub>16</sub>	Port P3 direction register (P3D)
0008 <sub>16</sub>	Port P4 (P4)
0009 <sub>16</sub>	Port P4 direction register (P4D)
000A <sub>16</sub>	Port P5 (P5)
000B <sub>16</sub>	Port P5 direction register (P5D)
000C <sub>16</sub>	Port P6 (P6)
000D <sub>16</sub>	Port P6 direction register (P6D)
000E <sub>16</sub>	Port P7 (P7)
000F <sub>16</sub>	Port P7 direction register (P7D)
0010 <sub>16</sub>	Port P8 (P8)
0011 <sub>16</sub>	Port P8 direction register (P8D)

Fig. 2.1.1 Memory map of I/O port related registers

### 2.1.2 Related registers

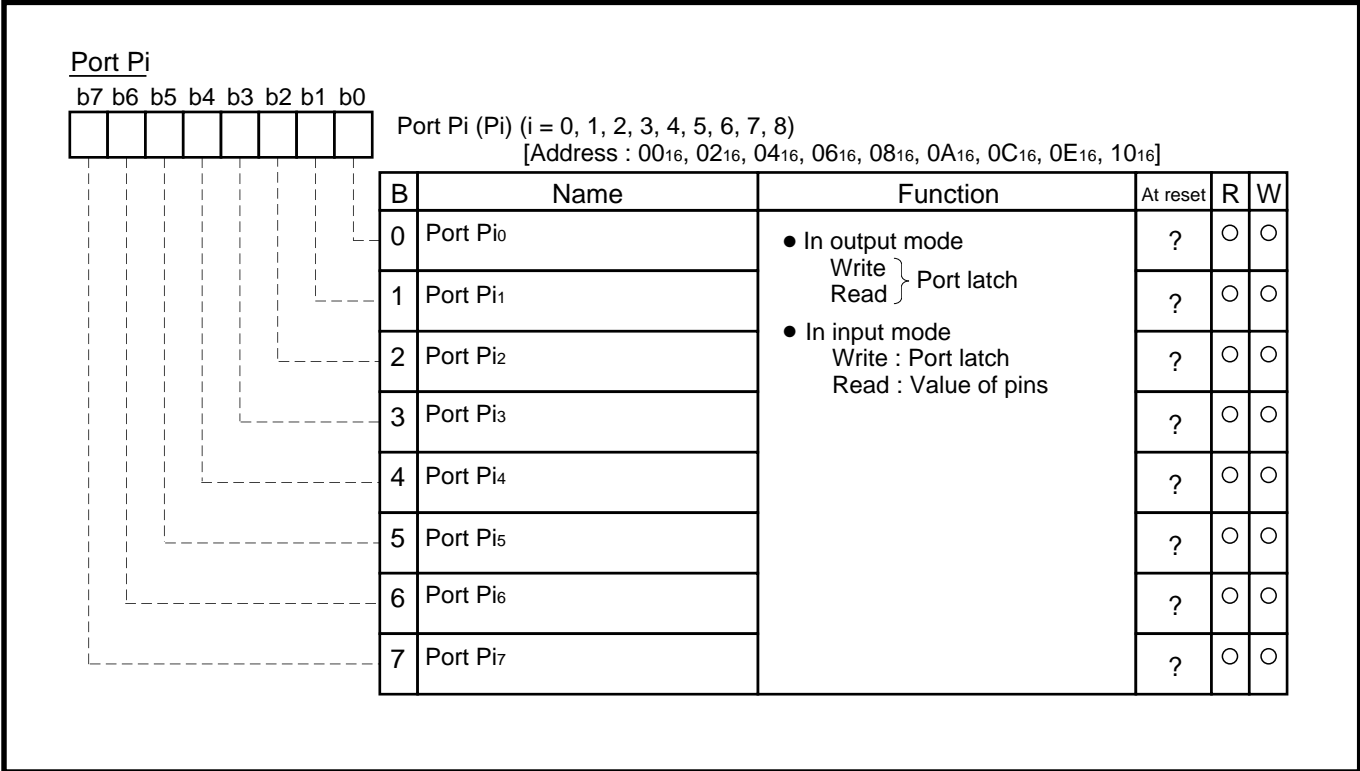

Fig. 2.1.2 Structure of Port Pi (i = 0, 1, 2, 3, 4, 5, 6, 7, 8)

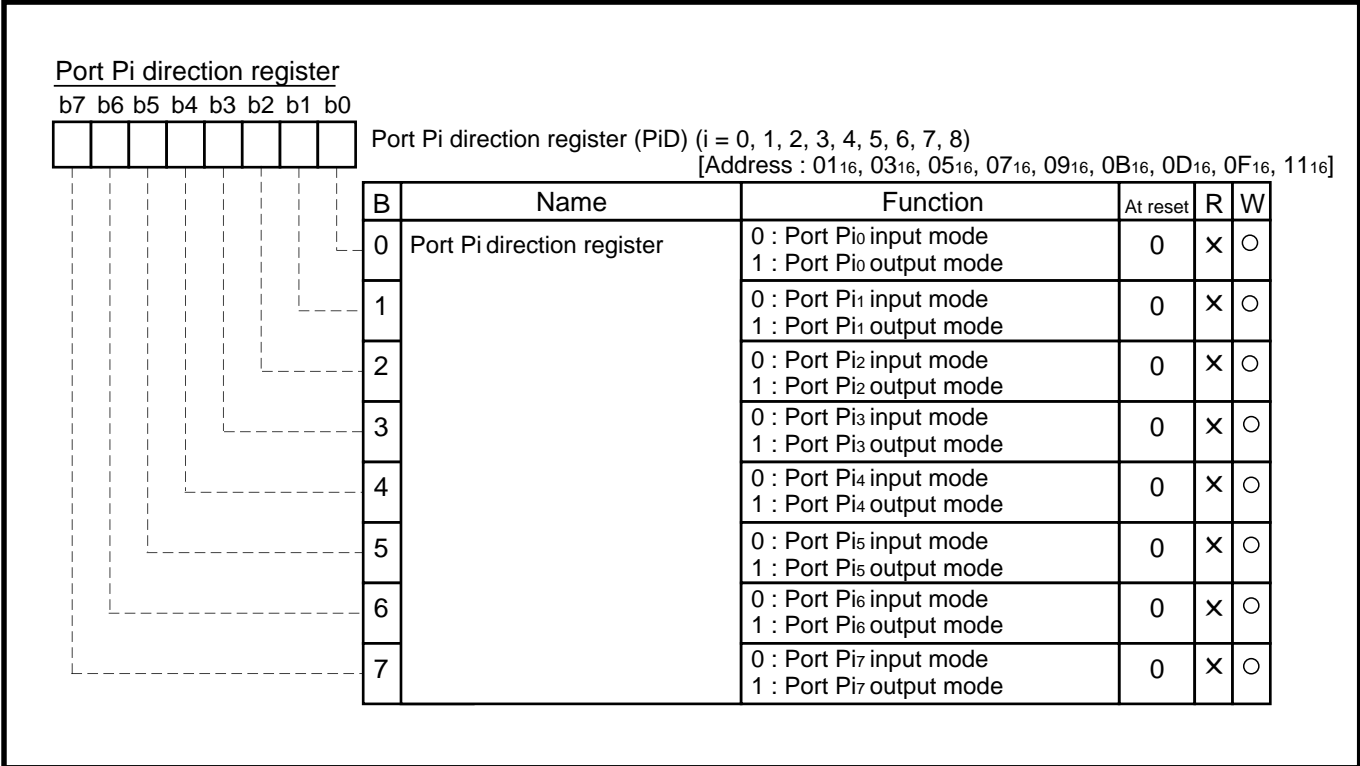

Fig. 2.1.3 Structure of Port Pi direction register (i = 0, 1, 2, 3, 4, 5, 6, 7, 8)

# APPLICATION

## 2.1 I/O port

### 2.1.3 Handling of unused pins

**Table 2.1.1 Handling of unused pins (in single-chip mode)**

Name of Pins/Ports	Handling
P0, P1, P2, P3, P4, P5, P6, P7, P8	<ul style="list-style-type: none"><li>• Set to the input mode and connect to VCC or Vss through a resistor of 1 kΩ to 10 kΩ.</li><li>• Set to the output mode and open at “L” or “H.”</li></ul>
VREF	Connect to Vss(GND) or open.
AVSS	Connect to Vss(GND).
XOUT	Open (only when using external clock).

**Table 2.1.2 Handling of unused pins (in memory expansion mode and microprocessor mode)**

Name of Pins/Ports	Handling
P30, P31	Open
P4, P5, P6, P7, P8	<ul style="list-style-type: none"><li>• Set to the input mode and connect to VCC or Vss through a resistor of 1 kΩ to 10 kΩ.</li><li>• Set to the output mode and open at “L” or “H.”</li></ul>
VREF	Connect to Vss(GND) or open.
ONW	Connect to Vcc through a resistor of 1 kΩ to 10 kΩ.
RESETOUT	Open
φ	Open
SYNC	Open
AVSS	Connect to Vss(GND).
XOUT	Open (only when using external clock).

### 2.2 Timer

#### 2.2.1 Memory map of timer

0020 <sub>16</sub>	Prescaler 12 (PRE12)
0021 <sub>16</sub>	Timer 1 (T1)
0022 <sub>16</sub>	Timer 2 (T2)
0023 <sub>16</sub>	Timer XY mode register (TM)
0024 <sub>16</sub>	Prescaler X (PREX)
0025 <sub>16</sub>	Timer X (TX)
0026 <sub>16</sub>	Prescaler Y (PREY)
0027 <sub>16</sub>	Timer Y (TY)
~	~
003C <sub>16</sub>	Interrupt request register 1 (IREQ1)
003D <sub>16</sub>	Interrupt request register 2 (IREQ2)
003E <sub>16</sub>	Interrupt control register 1 (ICON1)
003F <sub>16</sub>	Interrupt control register 2 (ICON2)

Fig. 2.2.1 Memory map of timer related registers



# APPLICATION

## 2.2 Timer

### 2.2.2 Related registers

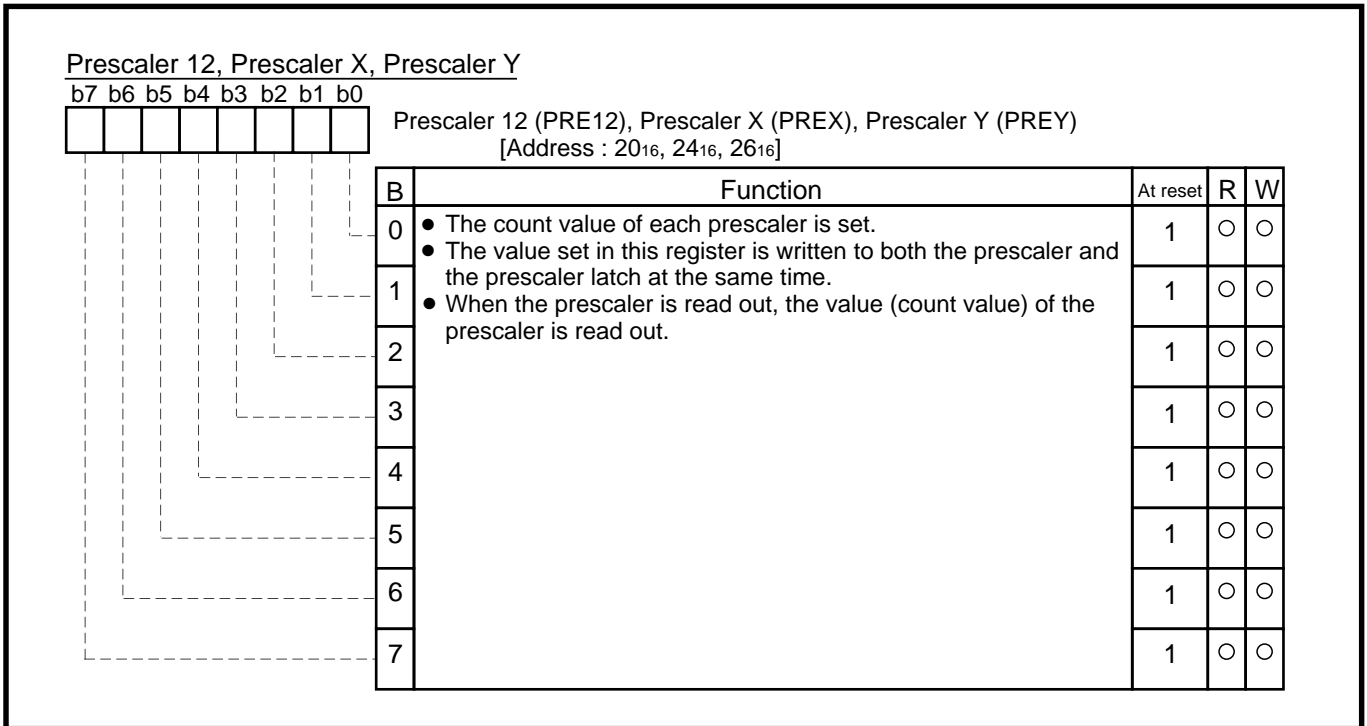

Fig. 2.2.2 Structure of Prescaler 12, Prescaler X, Prescaler Y

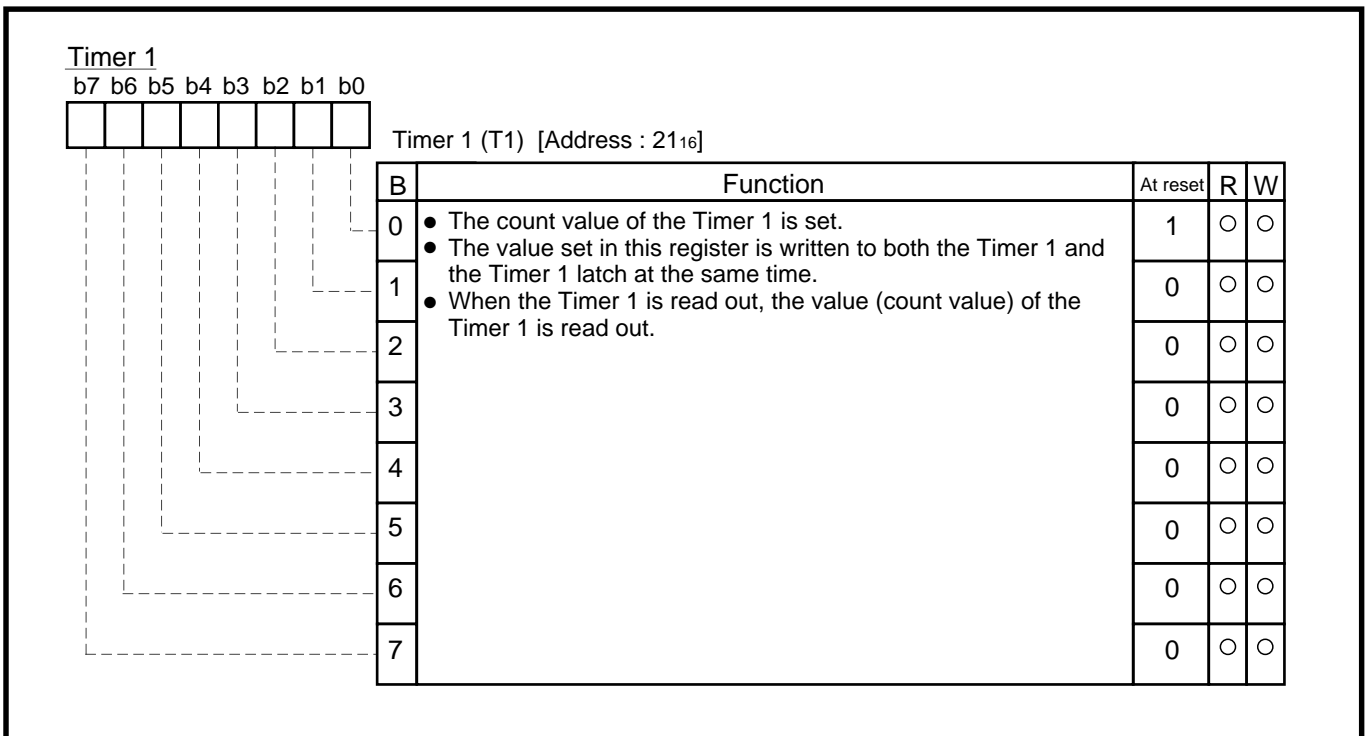

Fig. 2.2.3 Structure of Timer 1

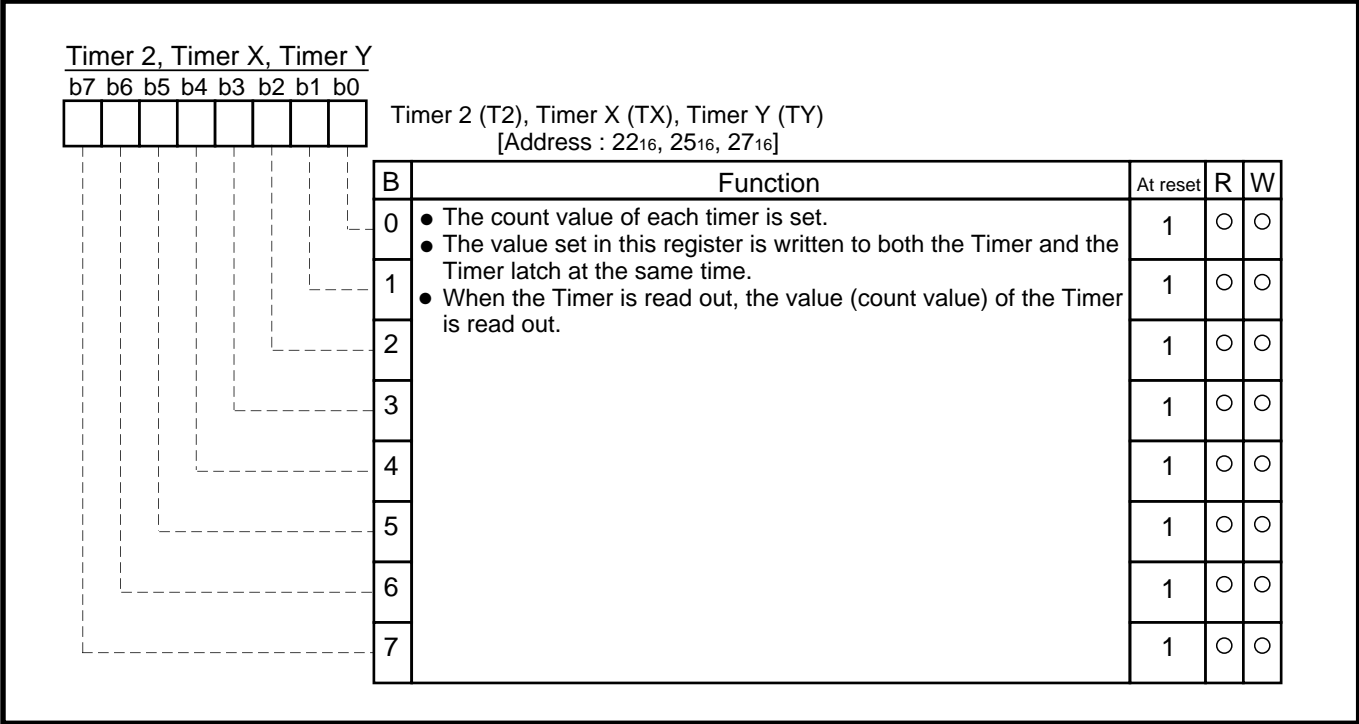

Fig. 2.2.4 Structure of Timer 2, Timer X, Timer Y

# APPLICATION

## 2.2 Timer

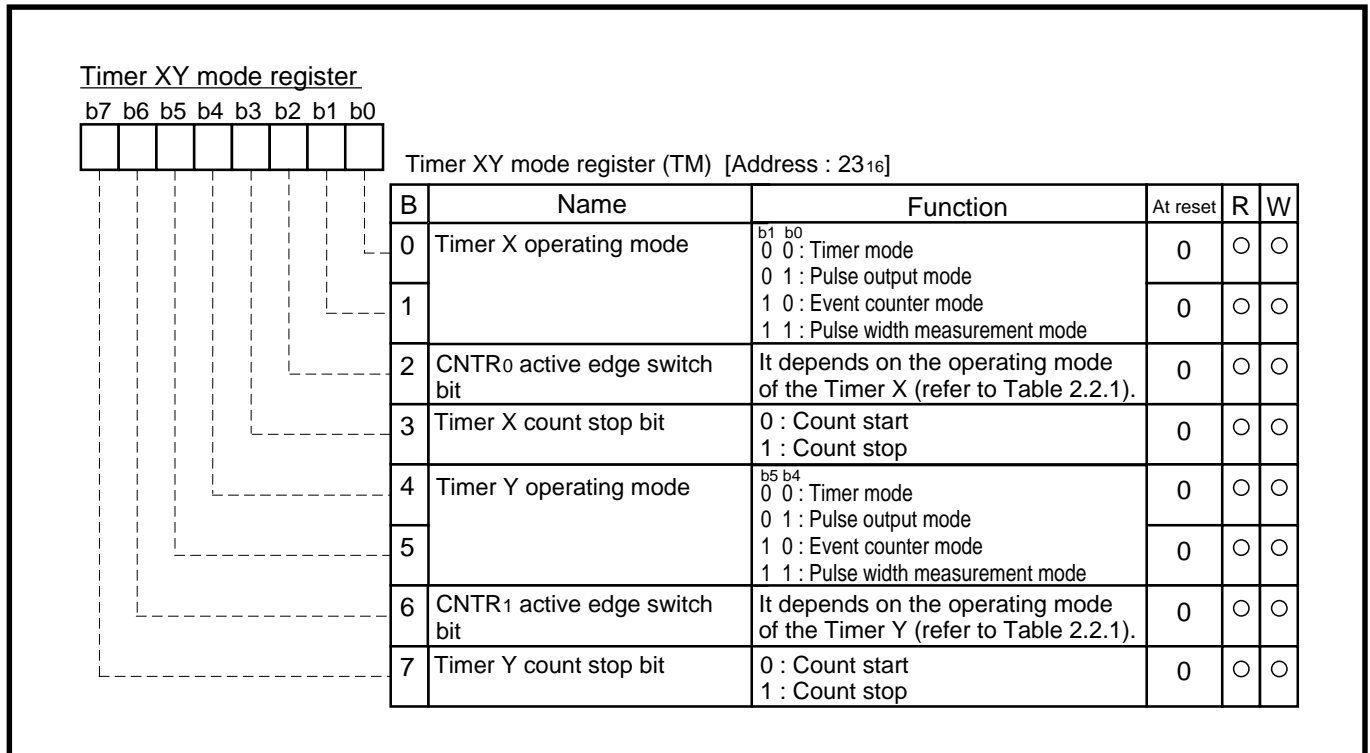

Fig. 2.2.5 Structure of Timer XY mode register

Table. 2.2.1 Function of CNTR0/CNTR1 edge switch bit

Operating mode of Timer X/Timer Y	Function of CNTR0/CNTR1 edge switch bit (bits 2 and 6)	
Timer mode	"0"	• Generation of CNTR0/CNTR1 interrupt request : Falling edge (No effect on timer count)
	"1"	• Generation of CNTR0/CNTR1 interrupt request : Rising edge (No effect on timer count)
Pulse output mode	"0"	• Start of pulse output : From "H" level • Generation of CNTR0/CNTR1 interrupt request : Falling edge
	"1"	• Start of pulse output : From "L" level • Generation of CNTR0/CNTR1 interrupt request : Rising edge
Event counter mode	"0"	• Timer X/Timer Y : Count of rising edge • Generation of CNTR0/CNTR1 interrupt request : Falling edge
	"1"	• Timer X/Timer Y : Count of falling edge • Generation of CNTR0/CNTR1 interrupt request : Rising edge
Pulse width measurement mode	"0"	• Timer X/Timer Y : Measurement of "H" level width • Generation of CNTR0/CNTR1 interrupt request : Falling edge
	"1"	• Timer X/Timer Y : Measurement of "L" level width • Generation of CNTR0/CNTR1 interrupt request : Rising edge

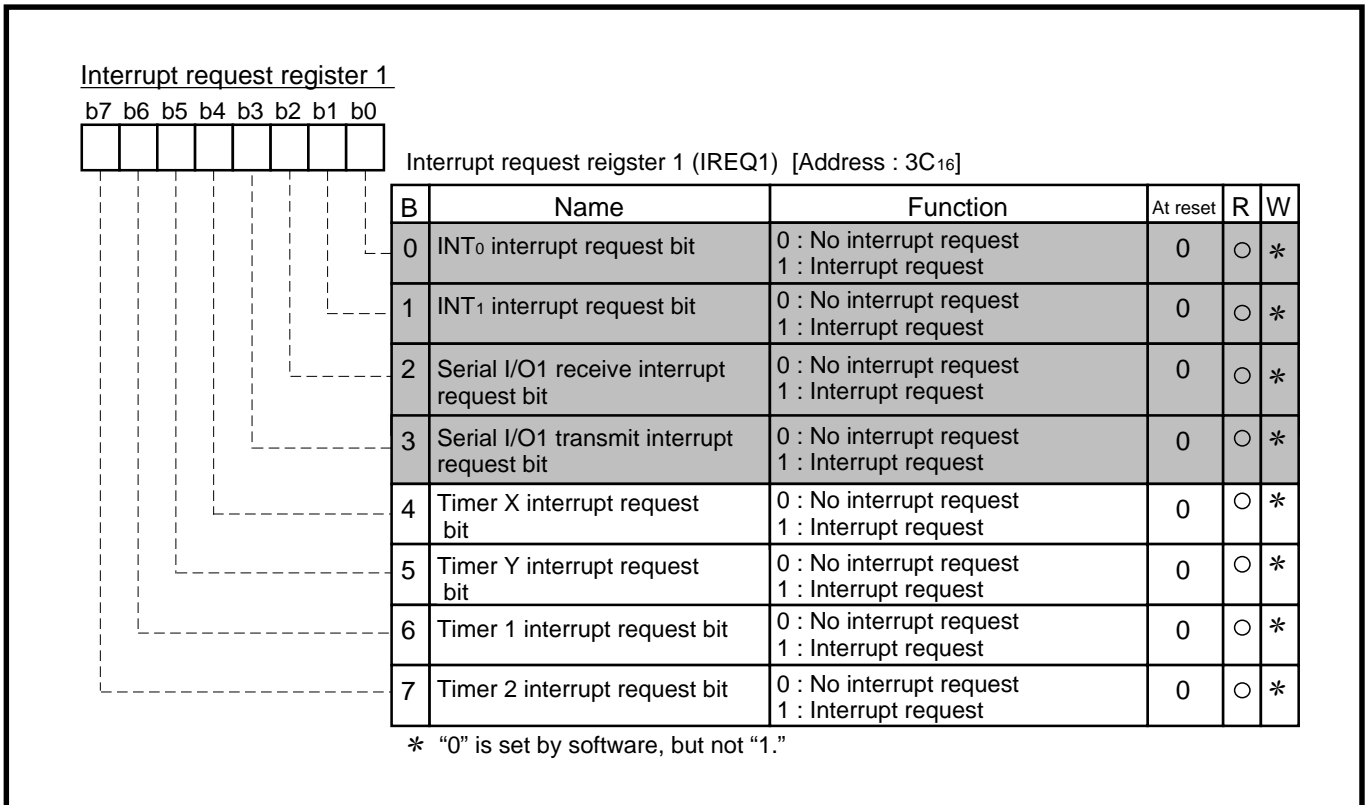

Fig. 2.2.6 Structure of Interrupt request register 1

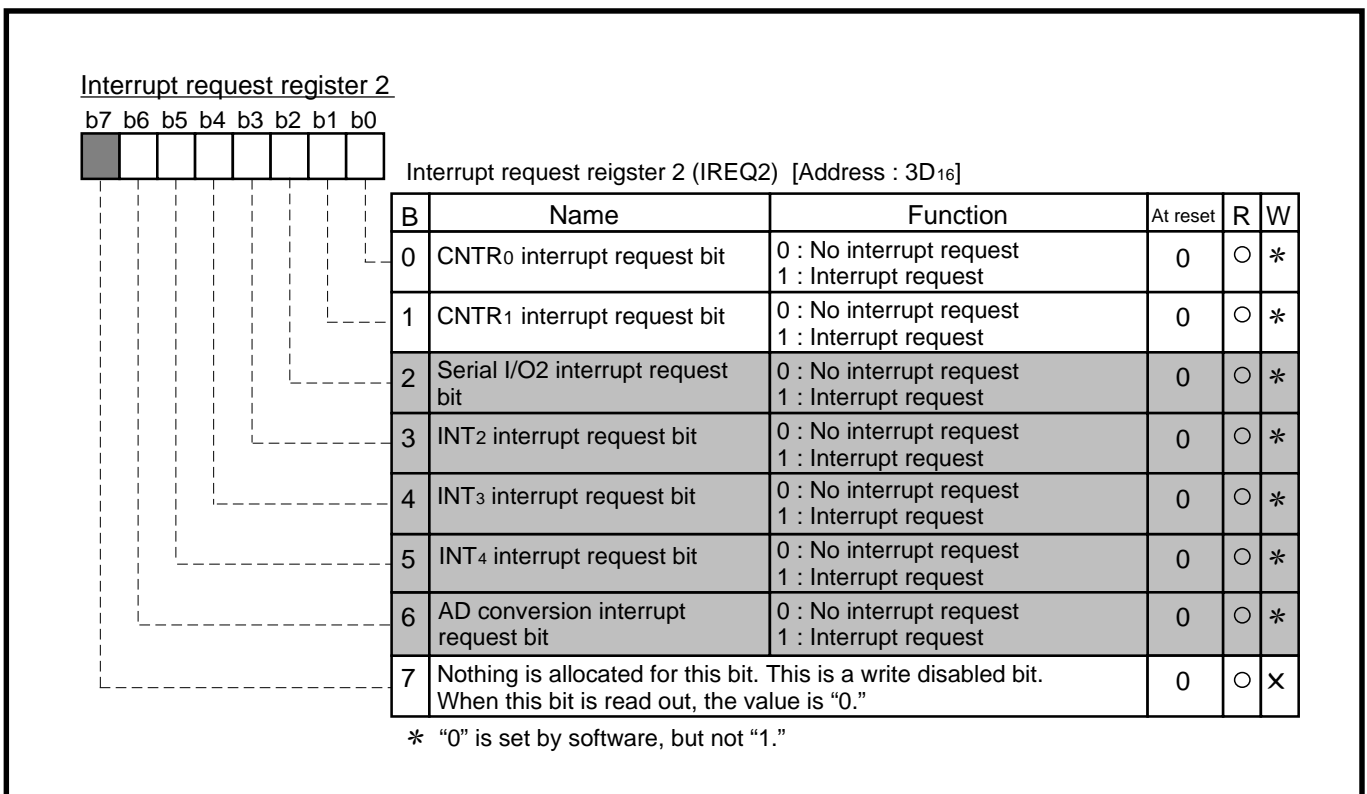

Fig. 2.2.7 Structure of Interrupt request register 2

# APPLICATION

## 2.2 Timer

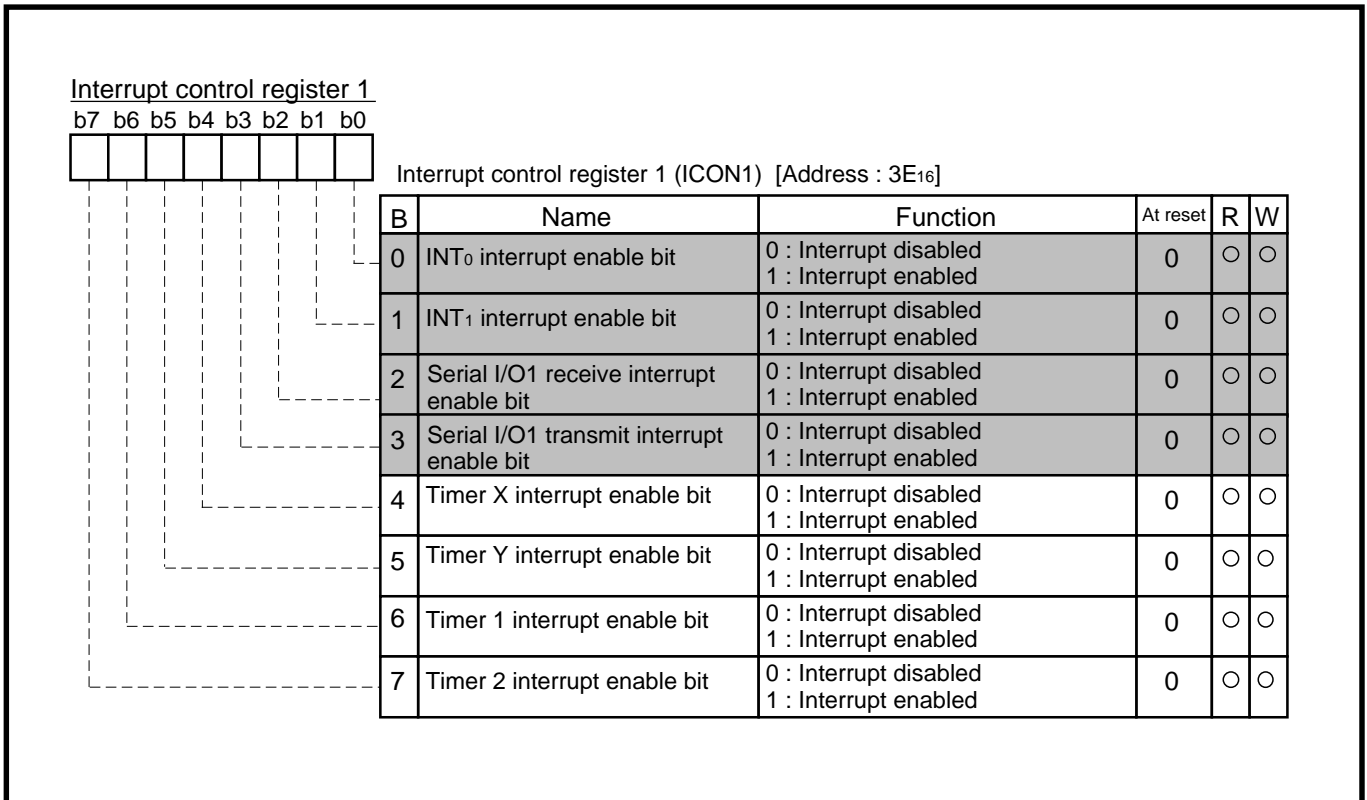

Fig. 2.2.8 Structure of Interrupt control register 1

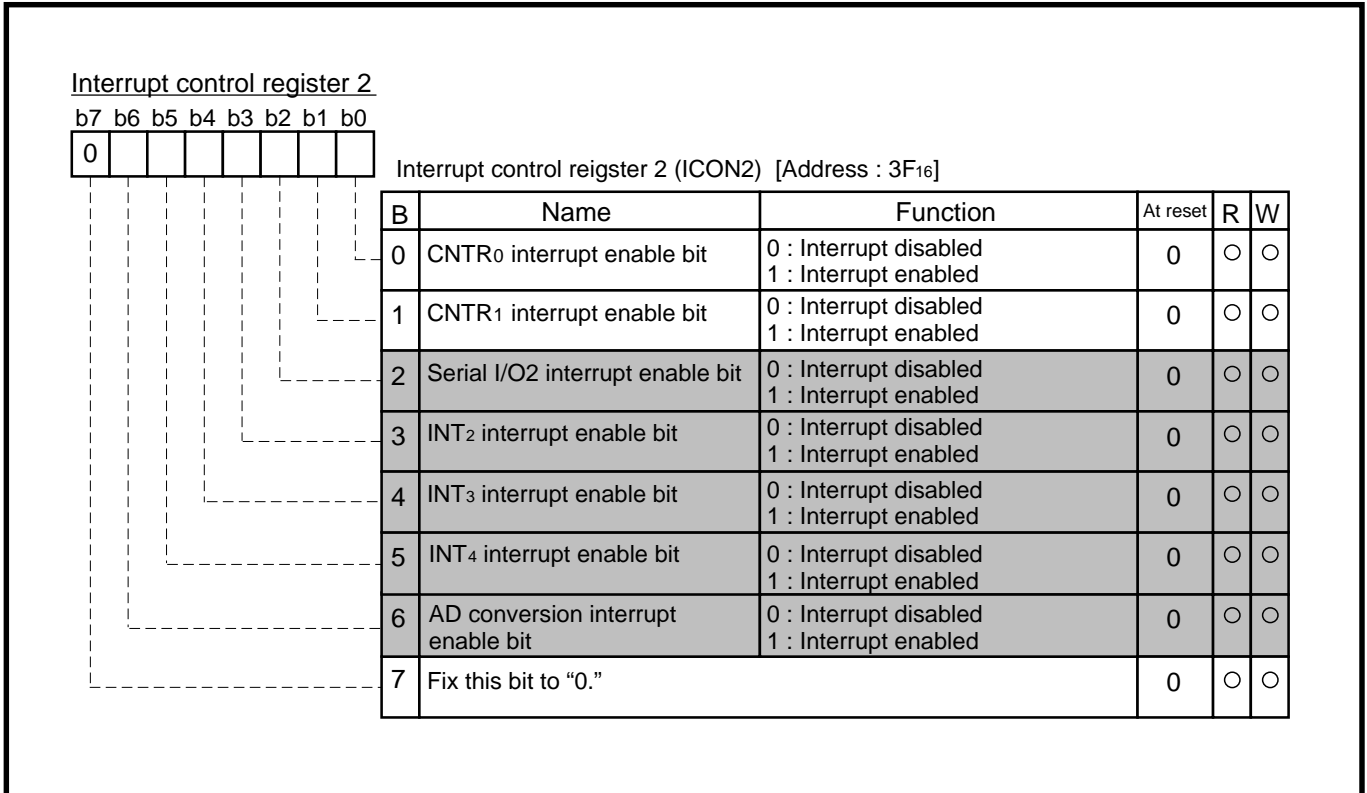

Fig. 2.2.9 Structure of Interrupt control register 2

### 2.2.3 Timer application examples

#### (1) Basic functions and uses

##### [Function 1] Control of Event interval (Timer X, Timer Y, Timer 1, Timer 2)

The Timer count stop bit is set to "0" after setting a count value to a timer. Then a timer interrupt request occurs after a certain period.

- [Use]
- Generation of an output signal timing
  - Generation of a waiting time

##### [Function 2] Control of Cyclic operation (Timer X, Timer Y, Timer 1, Timer 2)

The value of a timer latch is automatically written to a corresponding timer every time a timer underflows, and each cyclic timer interrupt request occurs.

- [Use]
- Generation of cyclic interrupts
  - Clock function (measurement of 250m second) → Application example 1
  - Control of a main routine cycle

##### [Function 3] Output of Rectangular waveform (Timer X, Timer Y)

The output level of the CNTR pin is inverted every time a timer underflows (Pulse output mode).

- [Use]
- A piezoelectric buzzer output → Application example 2
  - Generation of the remote-control carrier waveforms

##### [Function 4] Count of External pulse (Timer X, Timer Y)

External pulses input to the CNTR pin are selected as a timer count source (Event counter mode).

- [Use]
- Measurement of frequency → Application example 3
  - Division of external pulses.
  - Generation of interrupts in a cycle based on an external pulse.  
(count of a reel pulse)

##### [Function 5] Measurement of External pulse width (Timer X, Timer Y)

The "H" or "L" level width of external pulses input to CNTR pin is measured (Pulse width measurement mode).

- [Use]
- Measurement of external pulse frequency (Measurement of pulse width of FG pulse\* generated by motor) → Application example 4
  - Measurement of external pulse duty (when the frequency is fixed)

\*FG pulse : Pulse used for detecting the motor speed to control the motor speed.

# APPLICATION

## 2.2 Timer

### (2) Timer application example 1 : Clock function (measurement of 250 ms)

**Outline :** The input clock is divided by a timer so that the clock counts up every 250 ms.

- Specifications :**
- The clock  $f(X_{IN}) = 4.19 \text{ MHz}$  ( $2^{22} \text{ Hz}$ ) is divided by a timer.
  - The clock is counted at intervals of 250 ms by the Timer X interrupt.

Figure 2.2.10 shows a connection of timers and a setting of division ratios, Figure 2.2.11 shows a setting of related registers, and Figure 2.2.12 shows a control procedure.

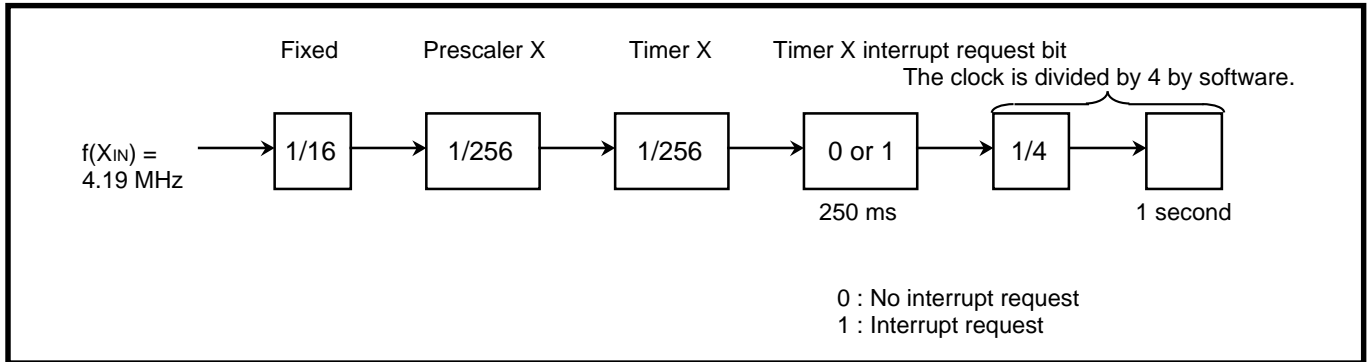

Fig. 2.2.10 Connection of timers and setting of division ratios [Clock function]

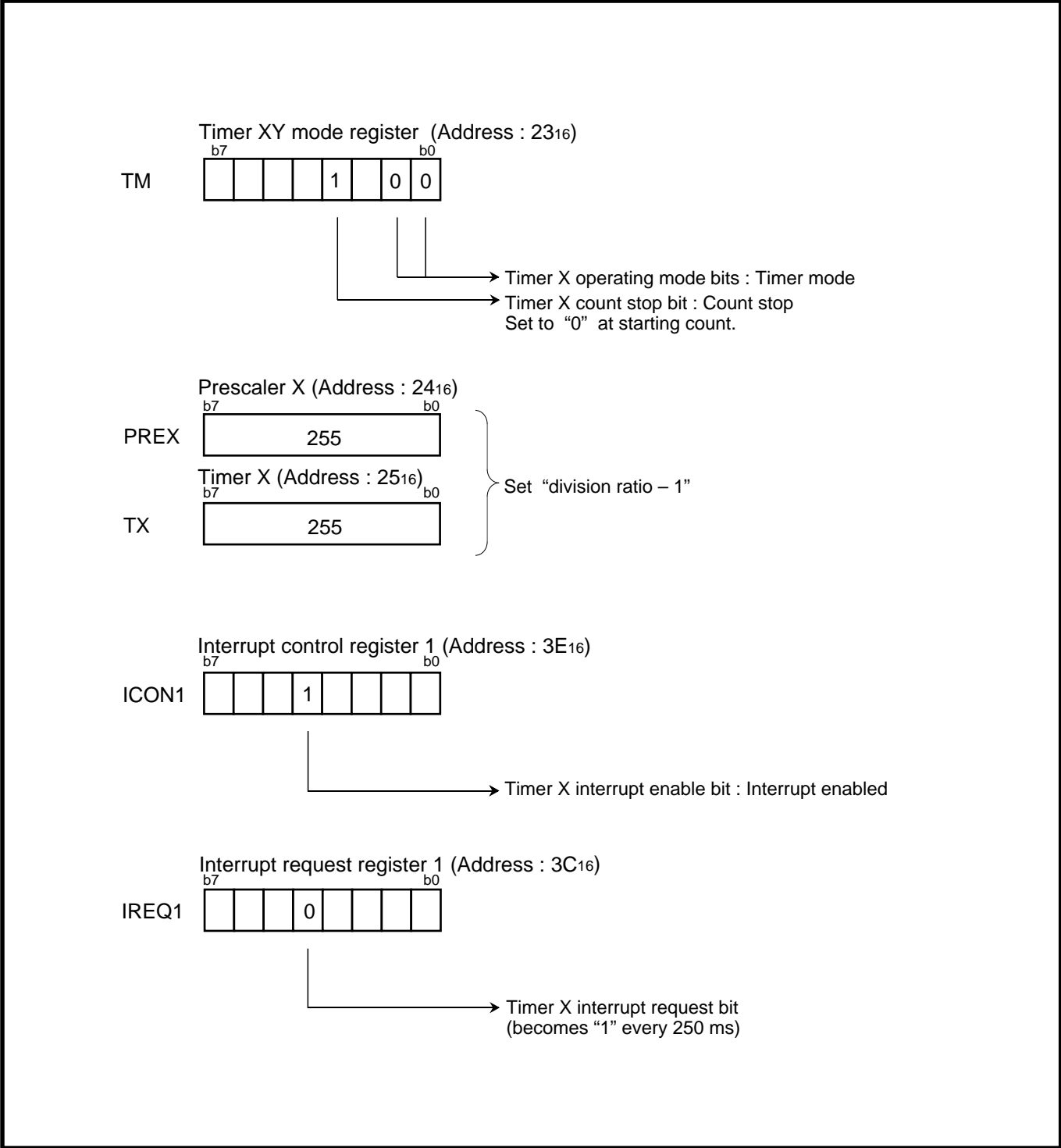

Fig. 2.2.11 Setting of related registers [Clock function]



# APPLICATION

## 2.2 Timer

### Control procedure :

Figure 2.2.12 shows a control procedure.

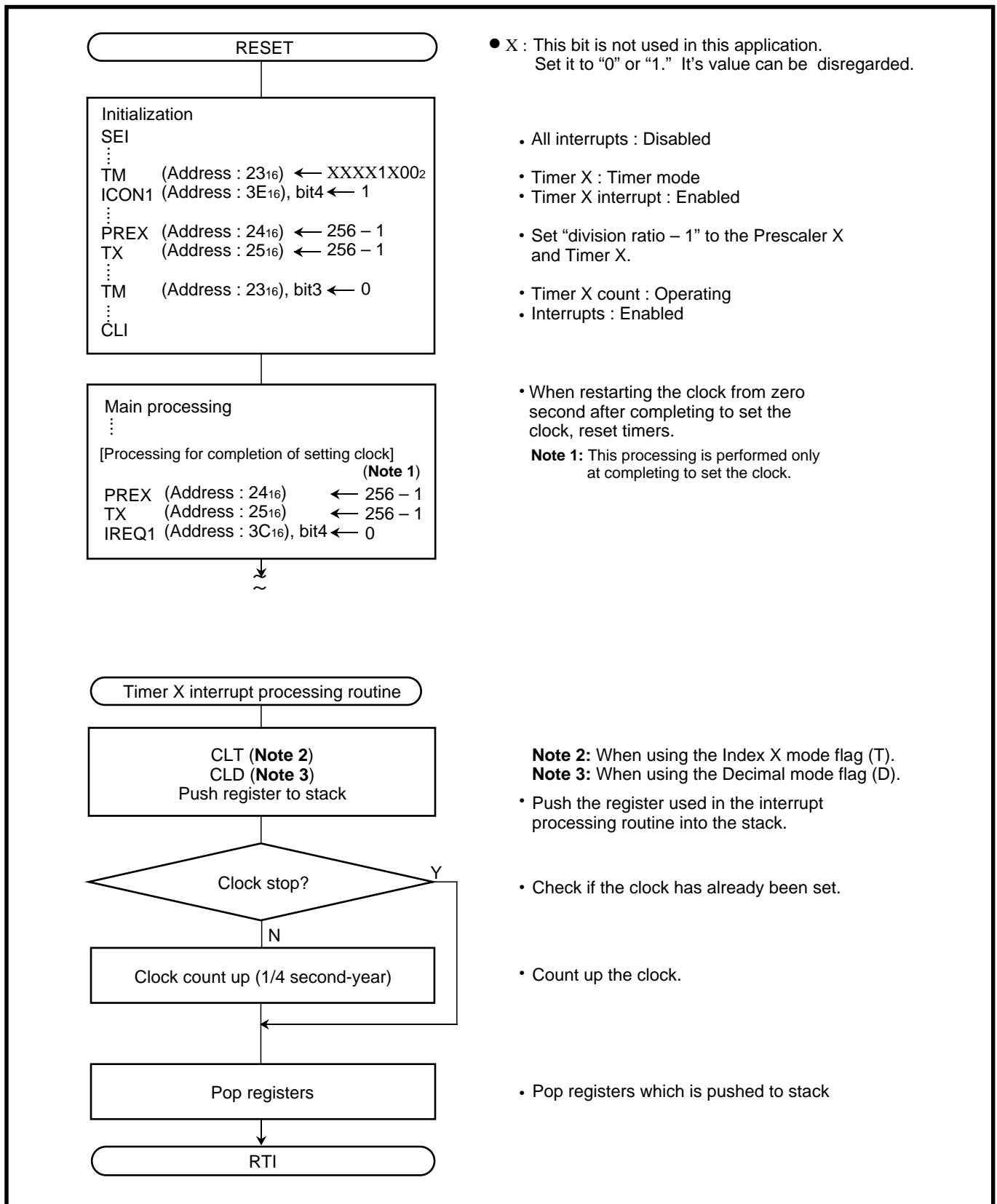

Fig. 2.2.12 Control procedure [Clock function]

(3) Timer application example 2 : Piezoelectric buzzer output

**Outline :** The rectangular waveform output function of a timer is applied for a piezoelectric buzzer output.

- Specifications :**
- The rectangular waveform resulting from dividing clock  $f(X_{IN}) = 4.19 \text{ MHz}$  into about 2 kHz (2048 Hz) is output from the P54/CNTR0 pin.
  - The level of the P54/CNTR0 pin fixes to "H" while a piezoelectric buzzer output is stopped.

Figure 2.2.13 shows an example of a peripheral circuit, and Figure 2.2.14 shows a connection of the timer and setting of the division ratio.

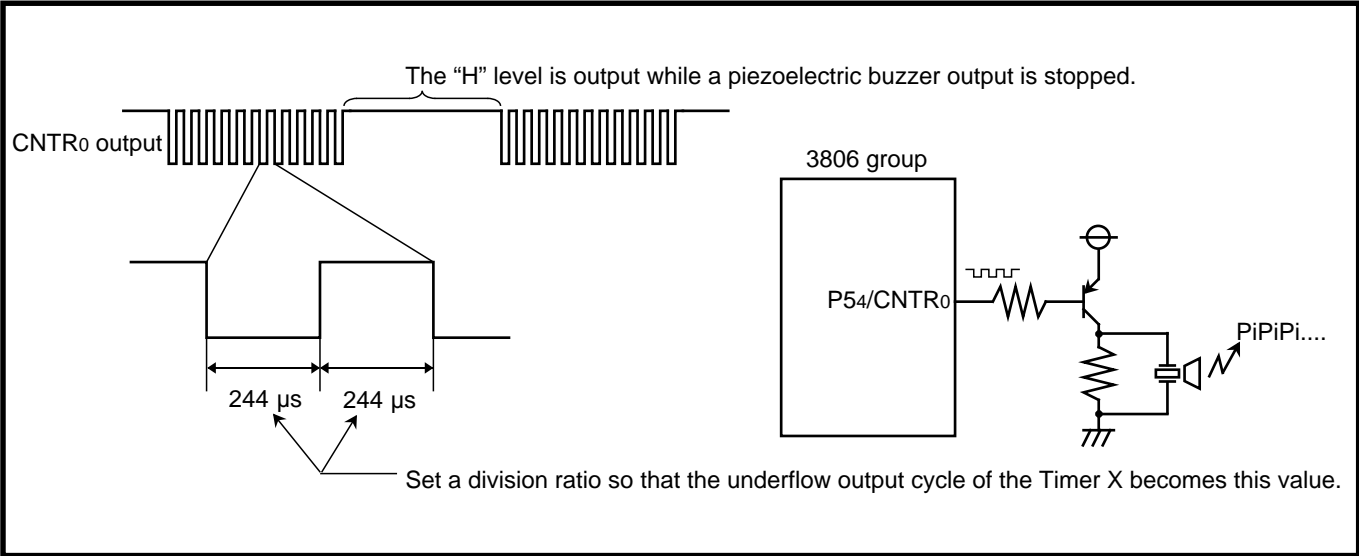

Fig. 2.2.13 Example of a peripheral circuit

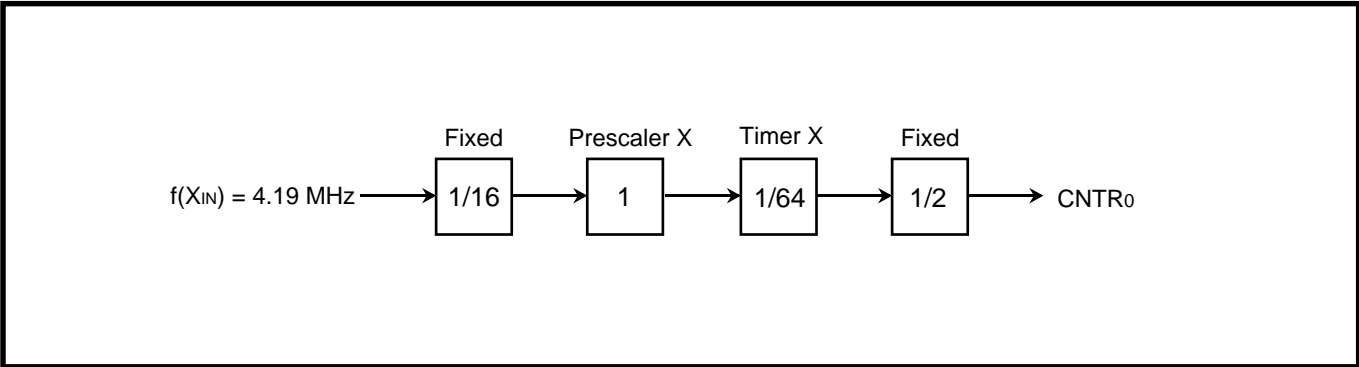

Fig. 2.2.14 Connection of the timer and setting of the division ratio [Piezoelectric buzzer output]



### (4) Timer application example 3 : Measurement of frequency

**Outline :** The following two values are compared for judging if the frequency is within a certain range.

- A value counted a pulse which is input to P55/CNTR1 pin by a timer.
- A reference value

**Specifications :** • The pulse is input to the P55/CNTR1 pin and counted by the Timer Y.

- A count value is read out at the interval of about 2 ms (Timer 1 interrupt interval :  $244 \mu\text{s} \times 8$ ). When the count value is 28 to 40, it is regarded the input pulse as a valid.
- Because the timer is a down-counter, the count value is compared with 227 to 215\* .  
\*  $227 \text{ to } 215 = 255 \text{ (initialized value of counter)} - 28 \text{ to } 40 \text{ (the number of valid value)}$ .

Figure 2.2.17 shows a method for judging if input pulse exists, and Figure 2.2.18 shows a setting of related registers.

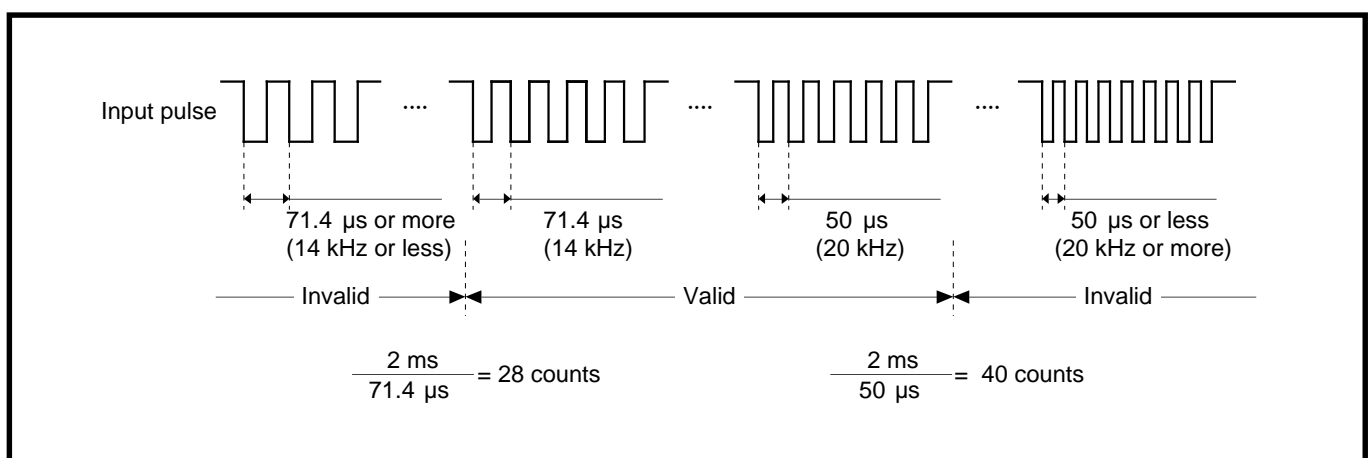

**Fig 2.2.17 A method for judging if input pulse exists**

# APPLICATION

## 2.2 Timer

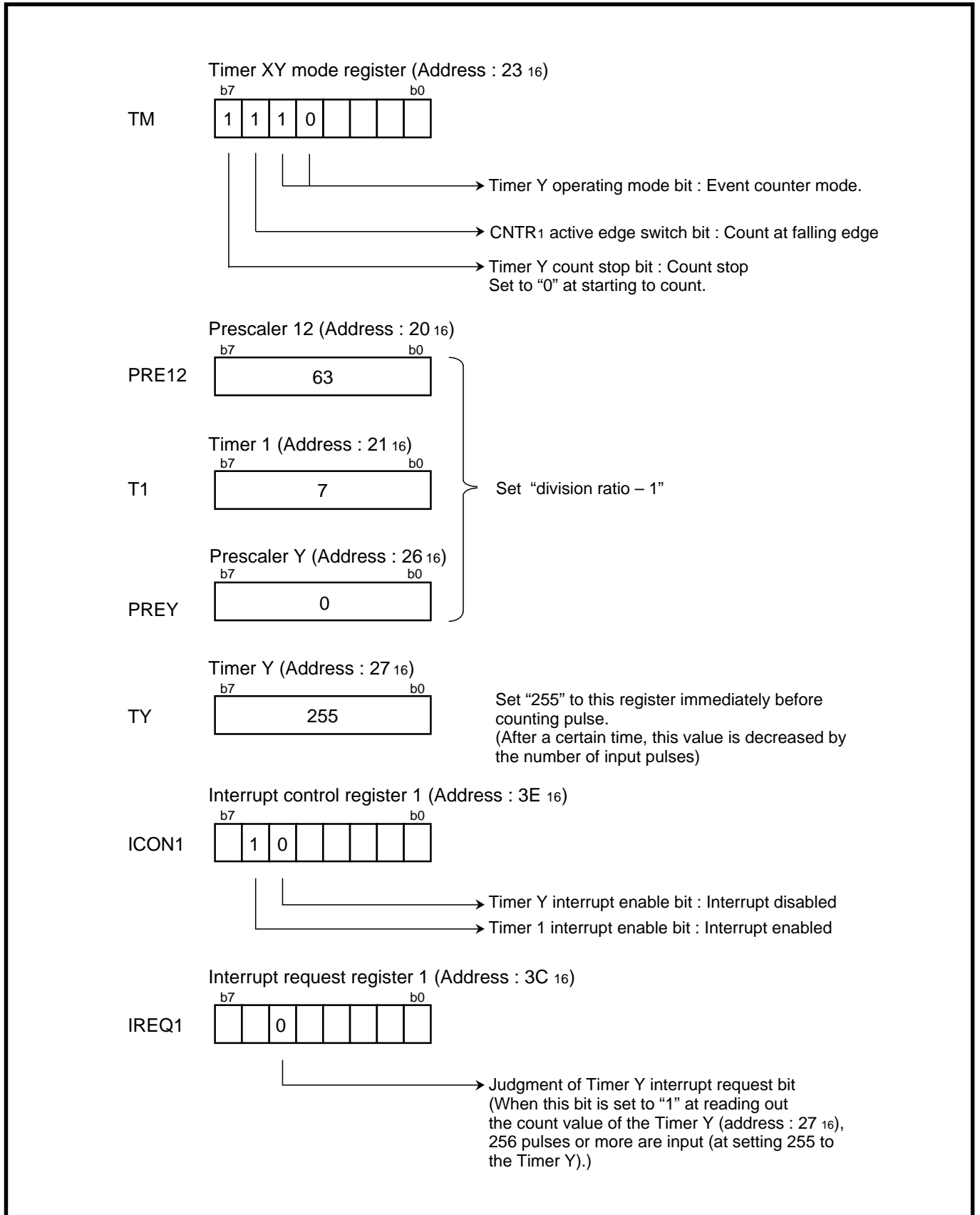

Fig. 2.2.18 Setting of related registers [Measurement of frequency]

### Control procedure :

Figure 2.2.19 shows a control procedure.

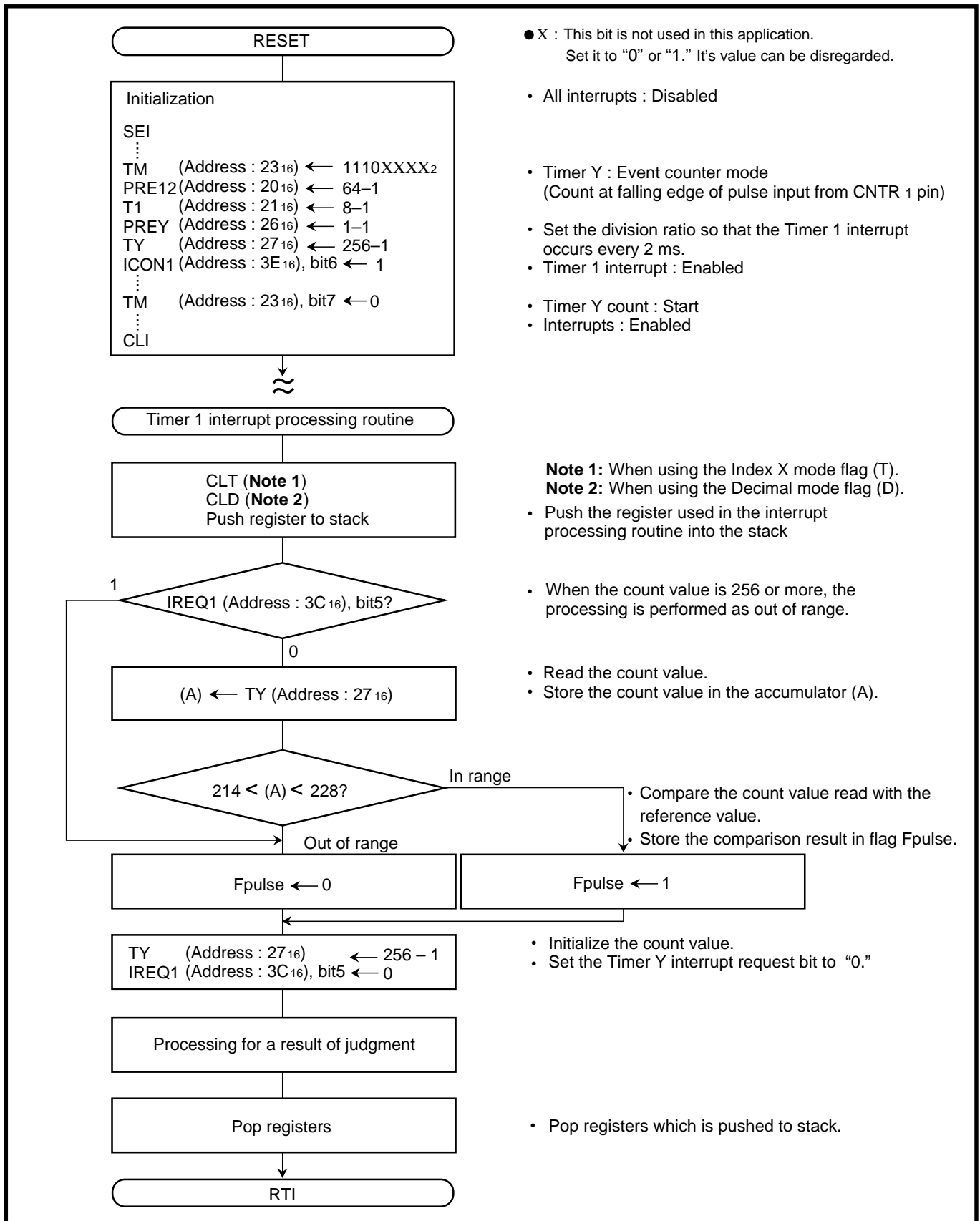

Fig. 2.2.19 Control procedure [Measurement of frequency]

# APPLICATION

## 2.2 Timer

### (5) Timer application example 4 : Measurement of pulse width of FG pulse generated by motor

**Outline** : The “H” level width of a pulse input to the P54/CNTR0 pin is counted by Timer X. An underflow is detected by Timer X interrupt and an end of the input pulse “H” level is detected by CNTR0 interrupt.

**Specifications** : • The “H” level width of FG pulse input to the P54/CNTR0 pin is counted by Timer X.

(Example : When the clock frequency is 4.19 MHz, the count source would be 3.8  $\mu$ s that is obtained by dividing the clock frequency by 16. Measurement can be made up to 250 ms in the range of FFFF<sub>16</sub> to 0000<sub>16</sub>.)

Figure 2.2.20 shows a connection of the timer and a setting of the division ratio, and Figure 2.2.21 shows a setting of related registers.

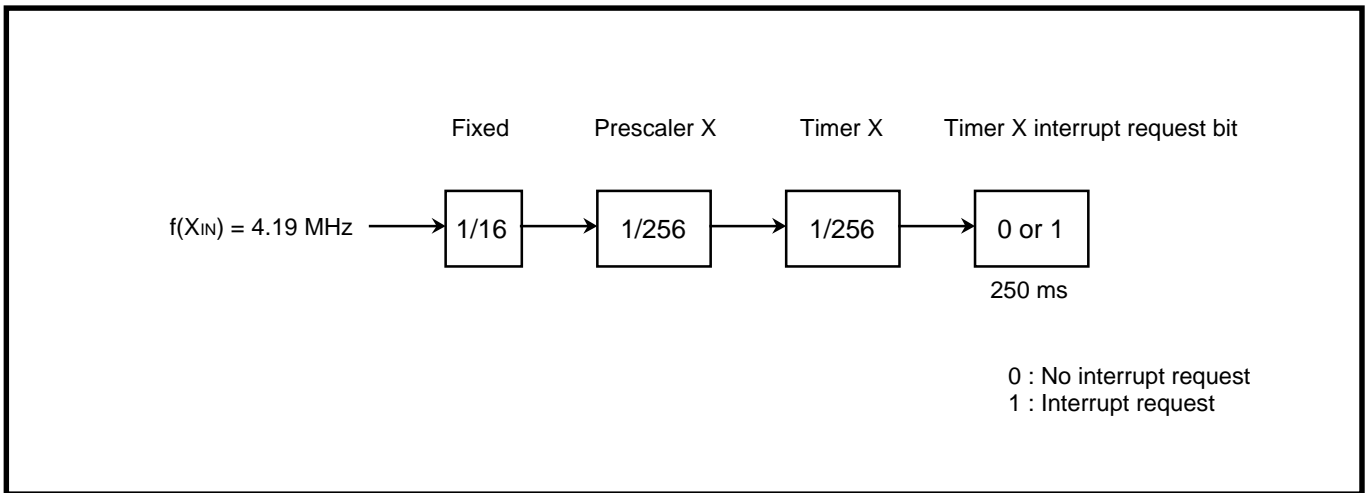

Fig. 2.2.20 Connection of the timer and setting of the division ratio [Measurement of pulse width]

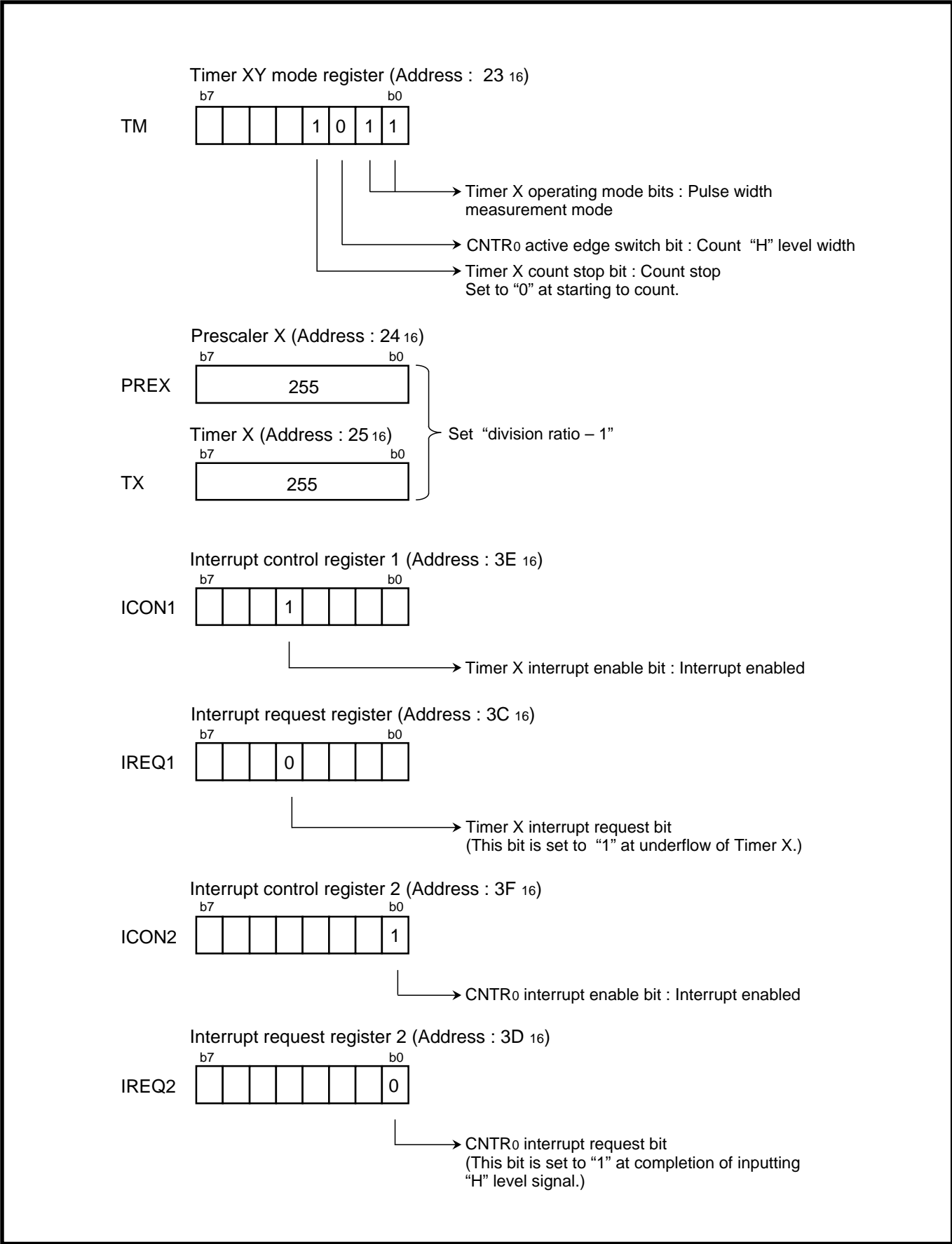

Fig. 2.2.21 Setting of related registers [Measurement of pulse width]



# APPLICATION

## 2.2 Timer

Figure 2.2.22 shows a control procedure.

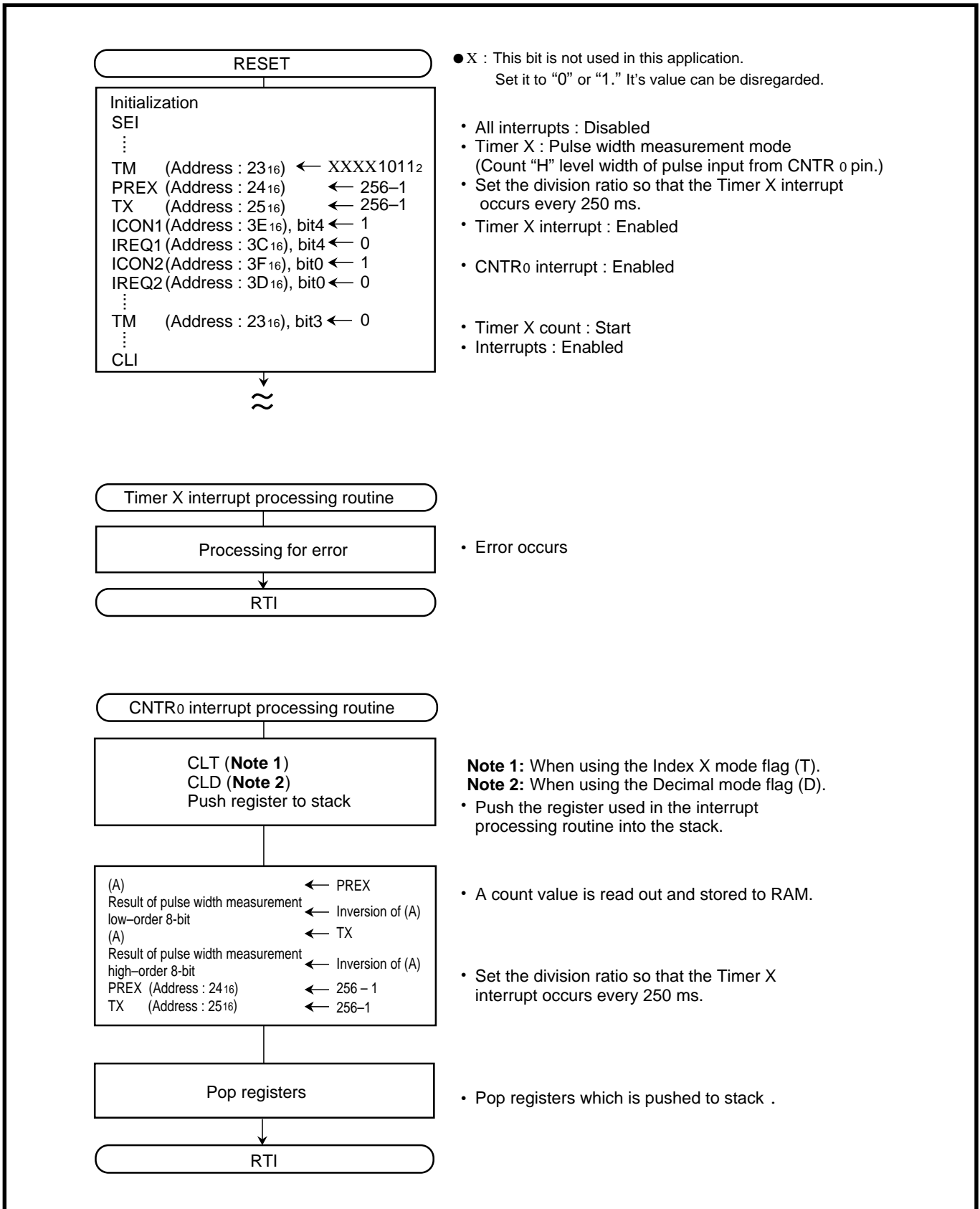
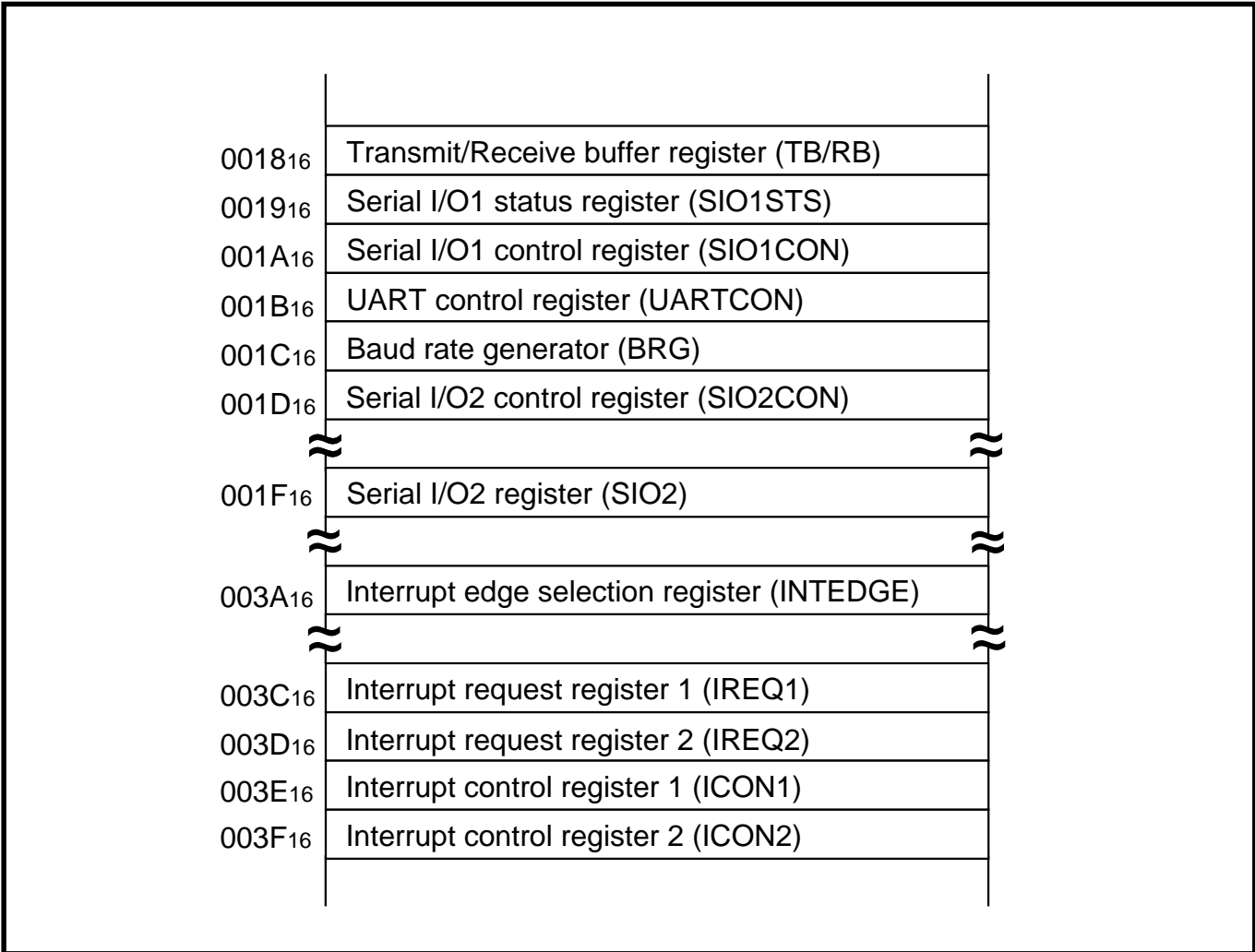

Fig. 2.2.22 Control procedure [Measurement of pulse width]

**2.3 Serial I/O**

**2.3.1 Memory map of serial I/O**



**Fig. 2.3.1 Memory map of serial I/O related registers**

# APPLICATION

## 2.3 Serial I/O

### 2.3.2 Related registers

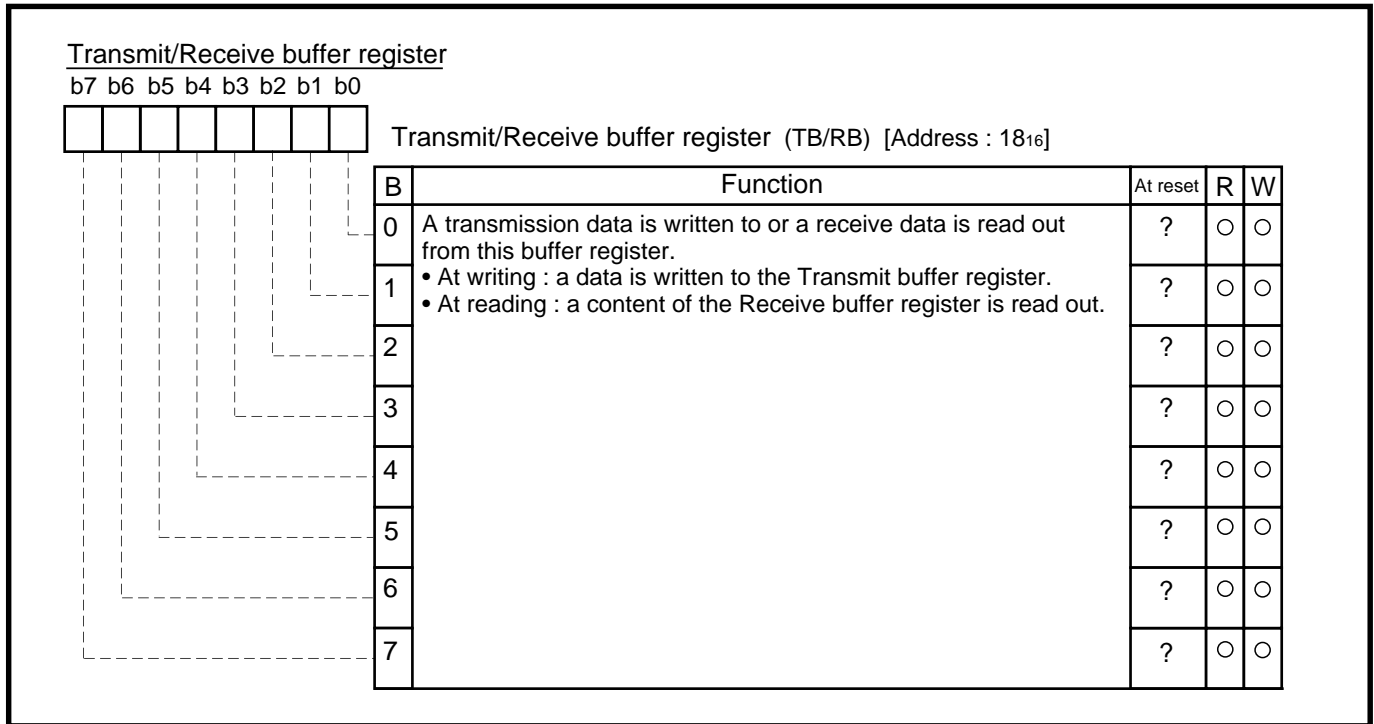

Fig. 2.3.2 Structure of Transmit/Receive buffer register

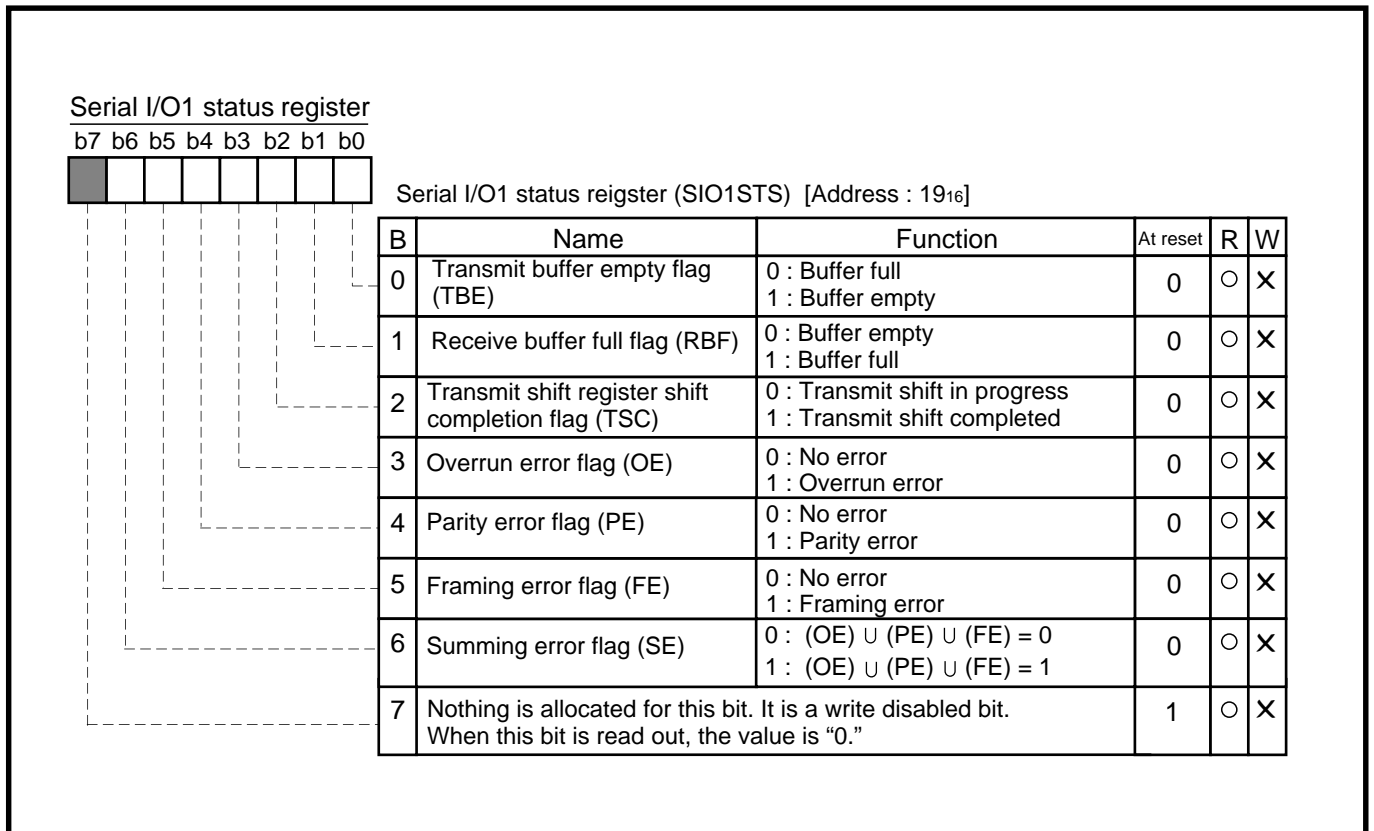

Fig. 2.3.3 Structure of Serial I/O1 status register

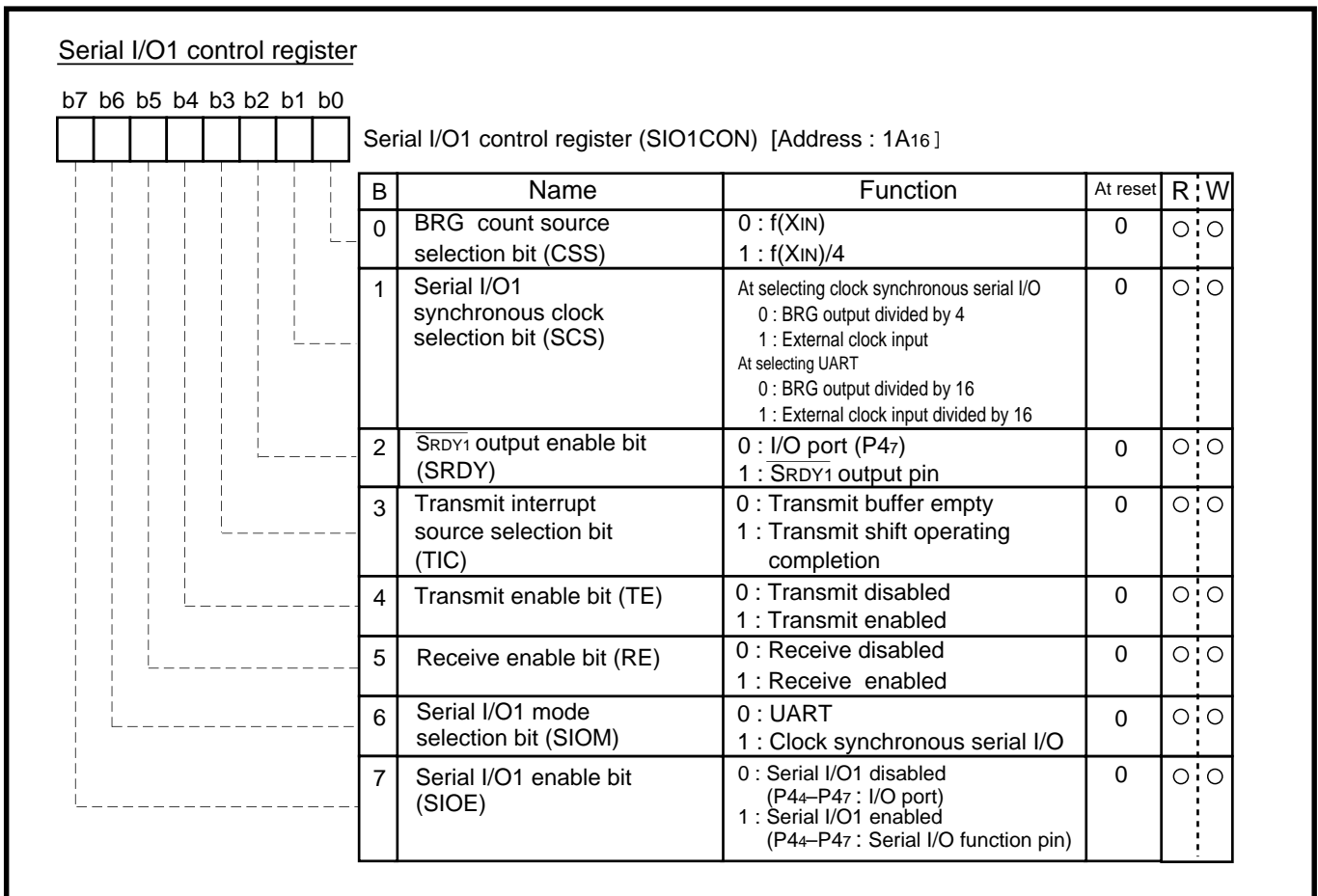

Fig. 2.3.4 Structure of Serial I/O1 control register

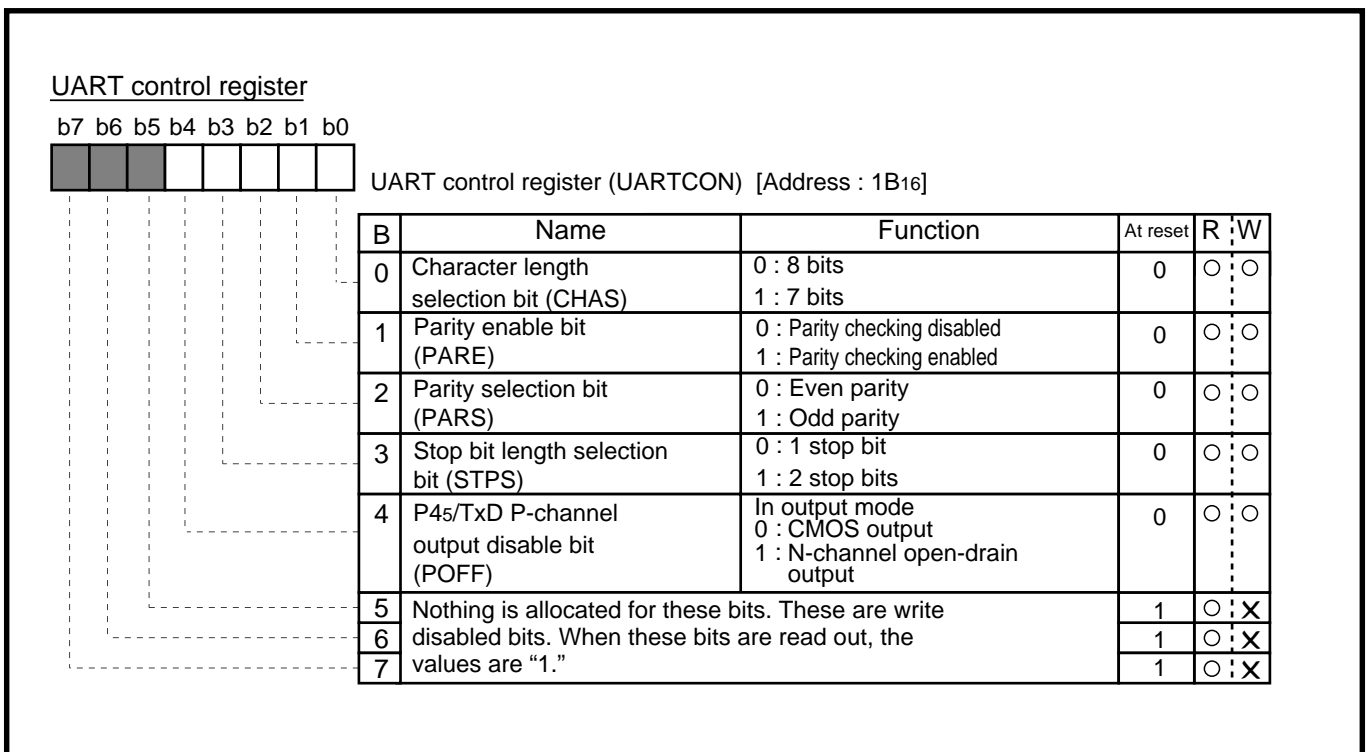

Fig. 2.3.5 Structure of UART control register

# APPLICATION

## 2.3 Serial I/O

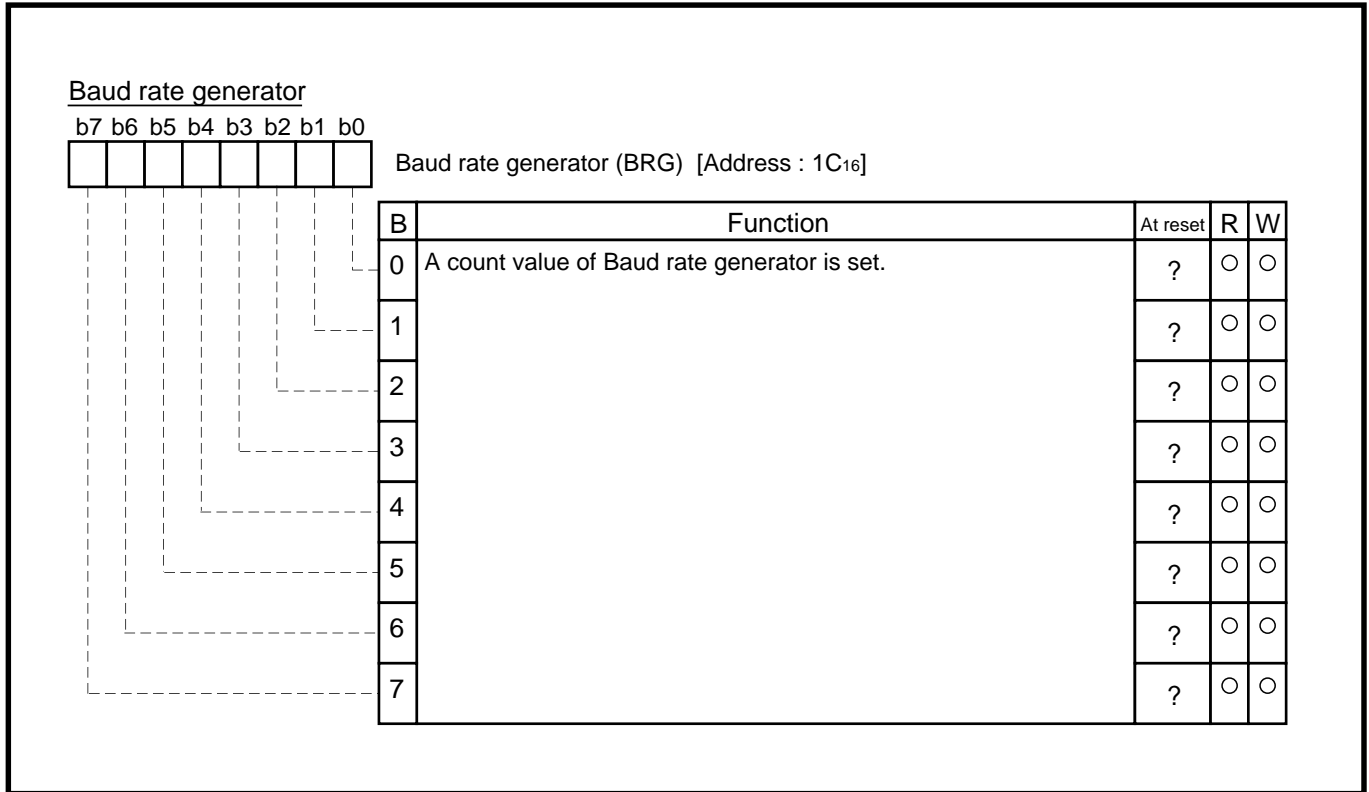

Fig. 2.3.6 Structure of Baud rate generator

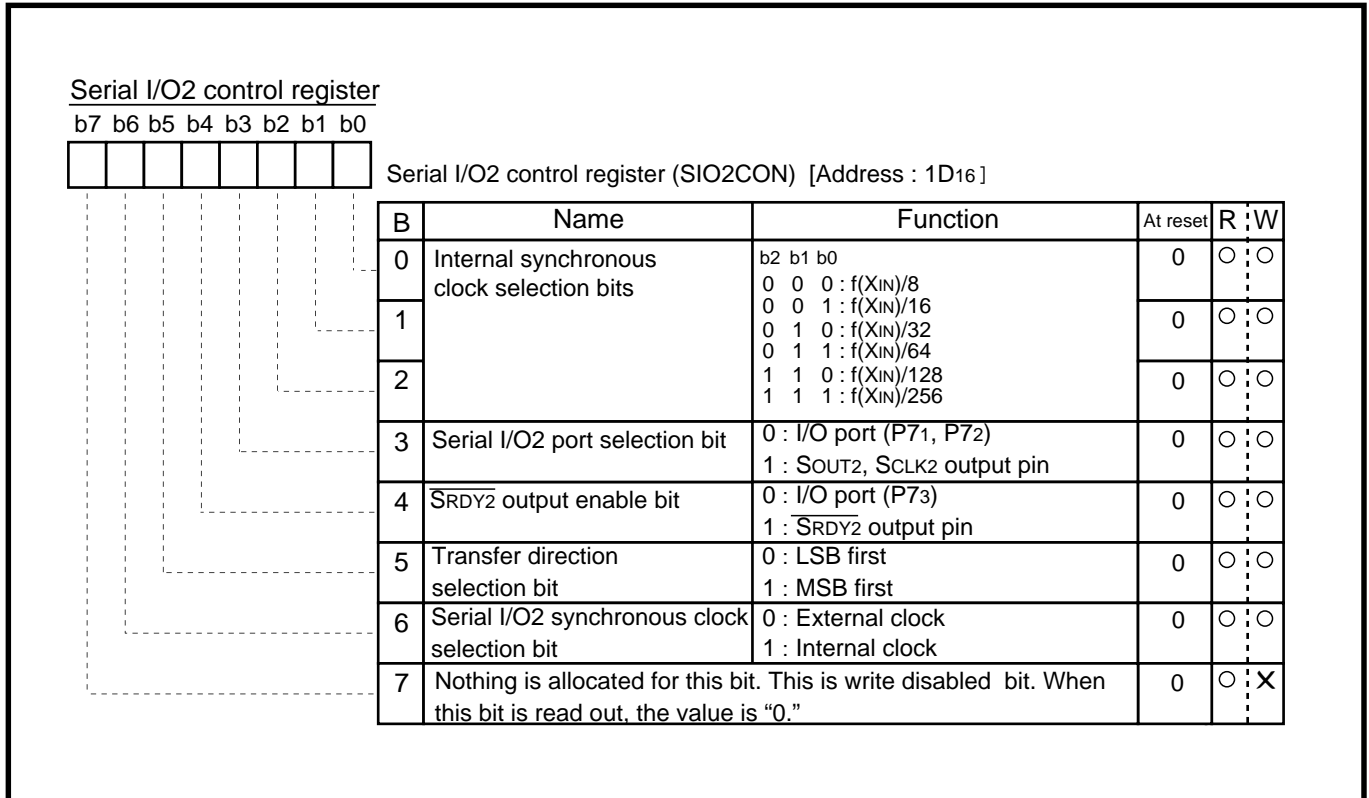

Fig. 2.3.7 Structure of Serial I/O2 control register

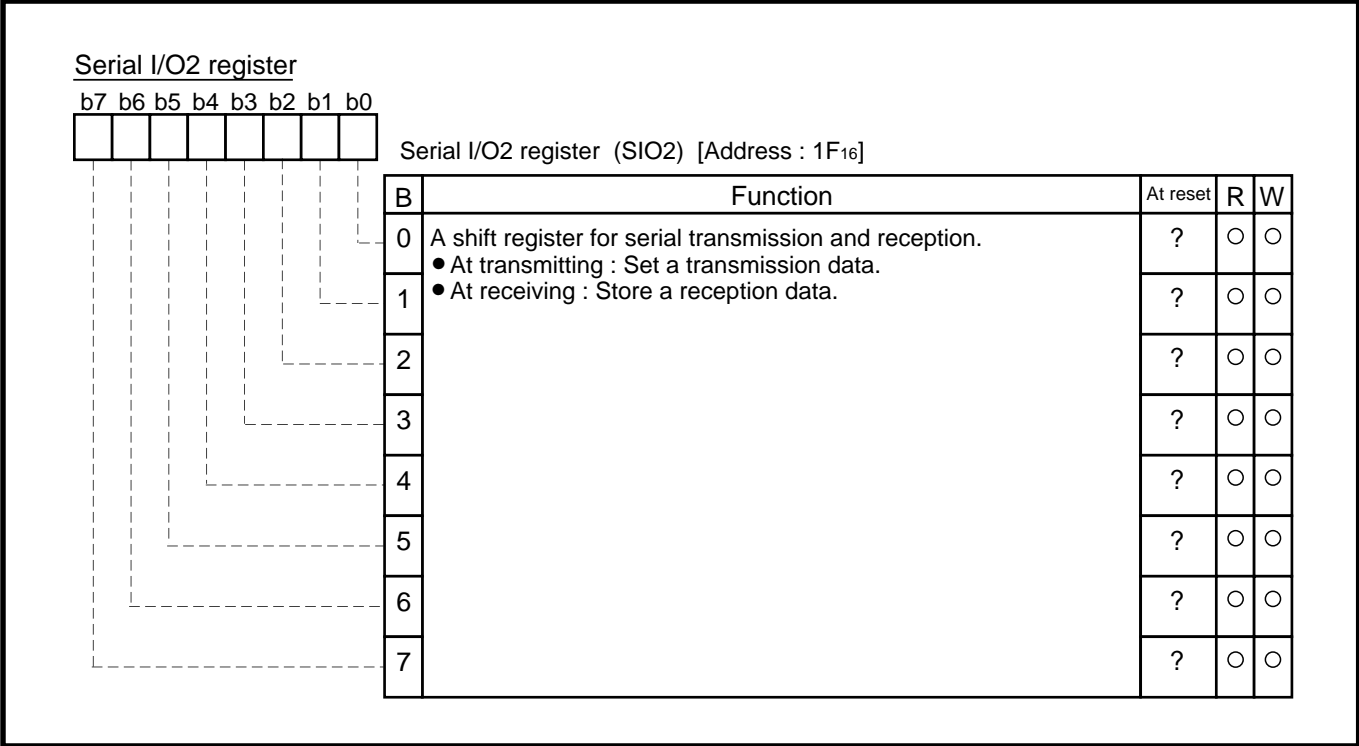

Fig. 2.3.8 Structure of Serial I/O2 register

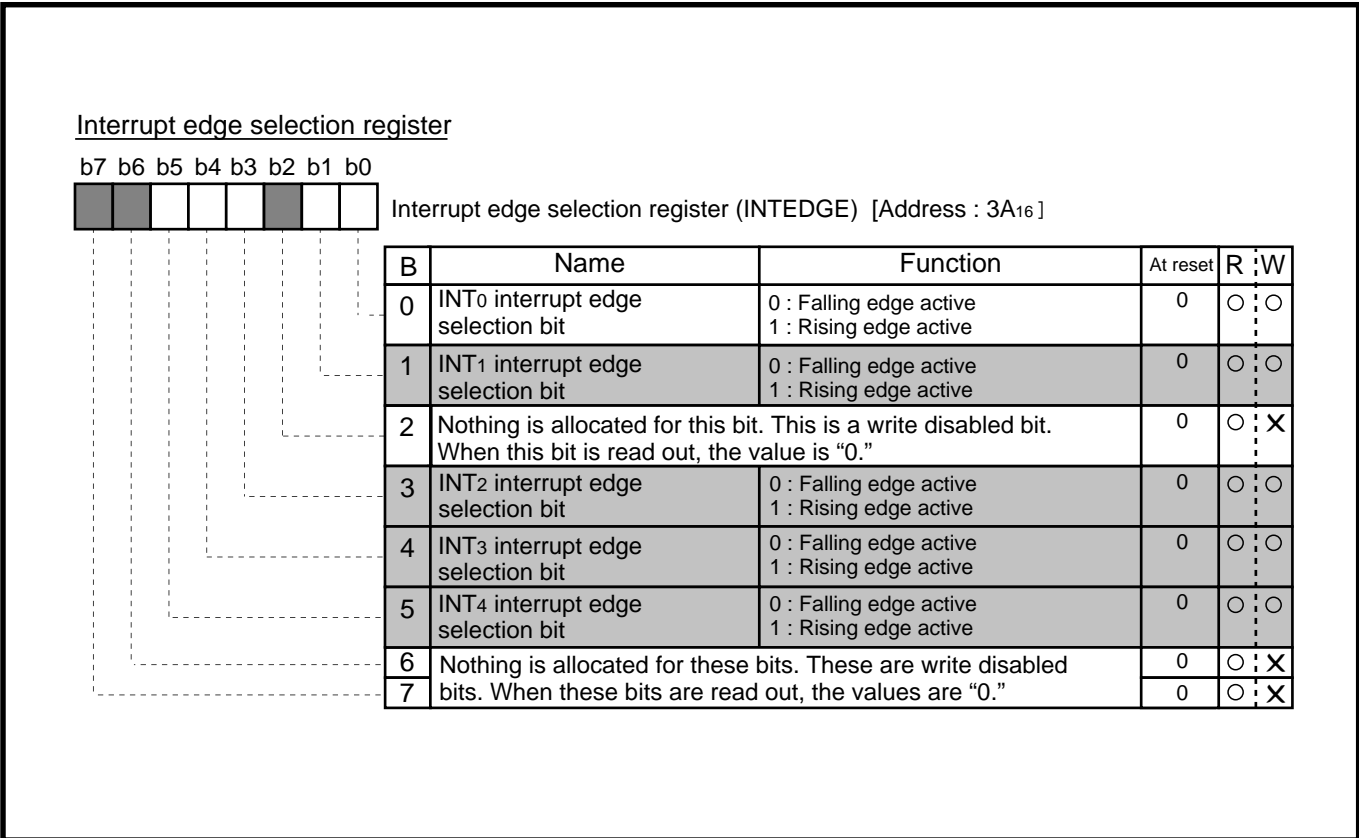

Fig. 2.3.9 Structure of Interrupt edge selection register

# APPLICATION

## 2.3 Serial I/O

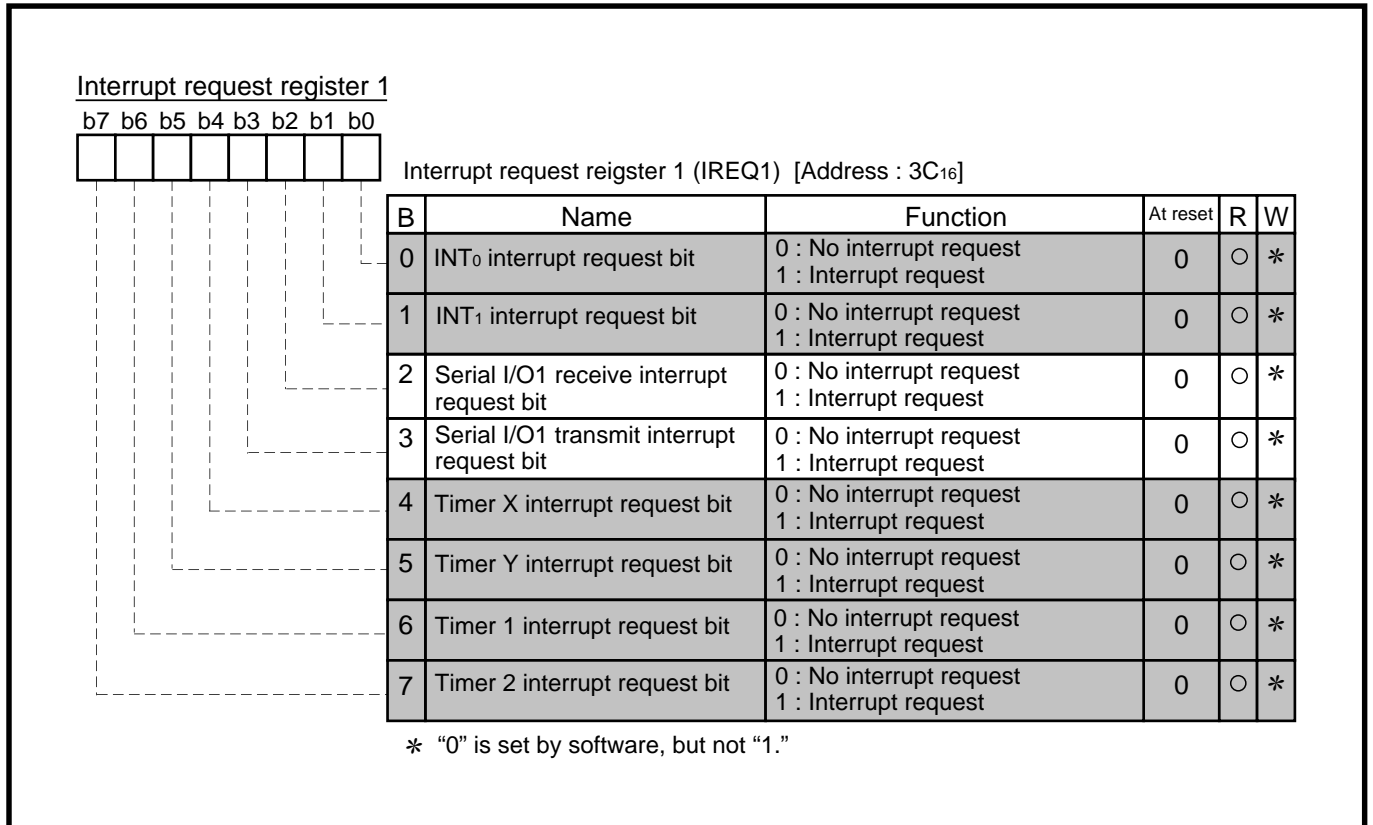

Fig. 2.3.10 Structure of Interrupt request register 1

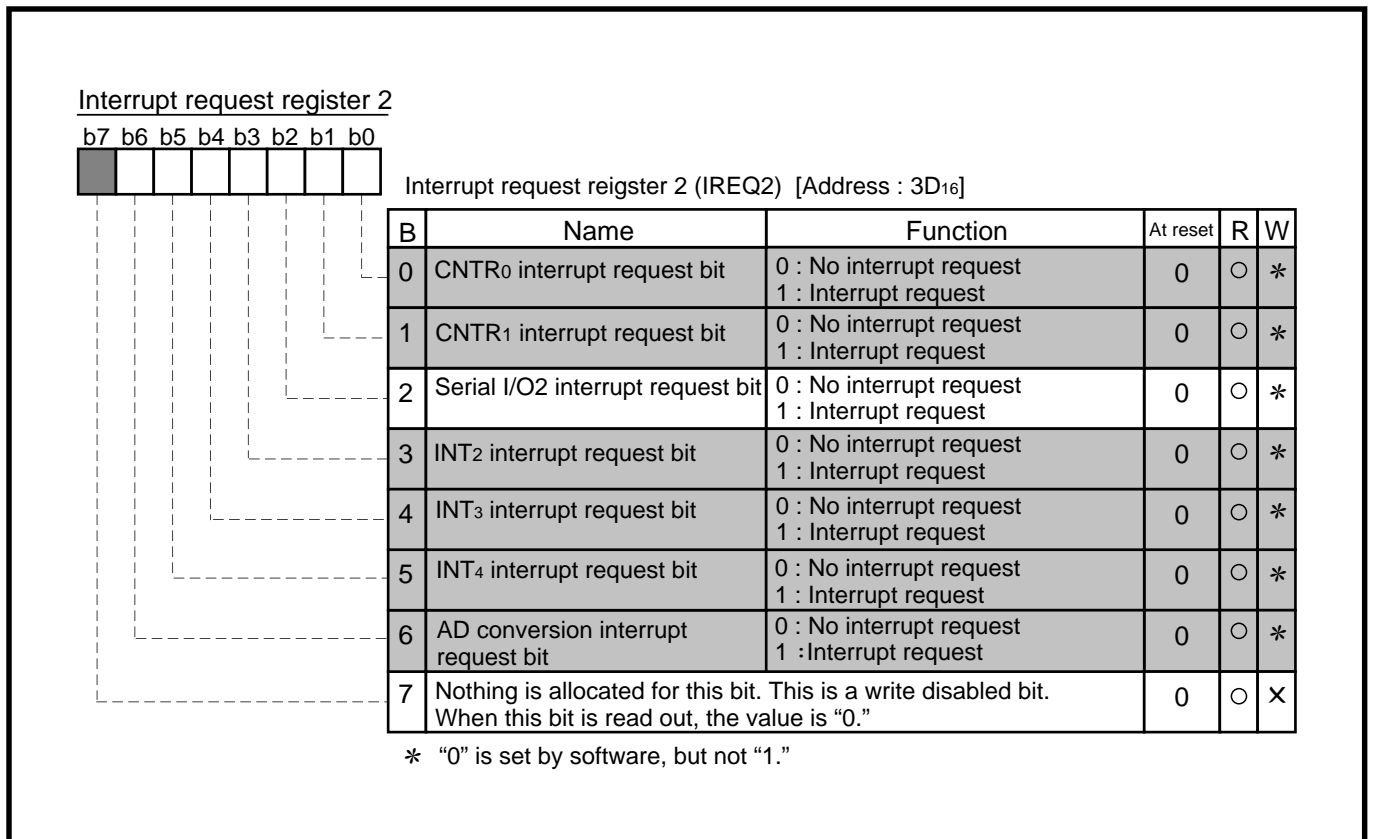

Fig. 2.3.11 Structure of Interrupt request register 2

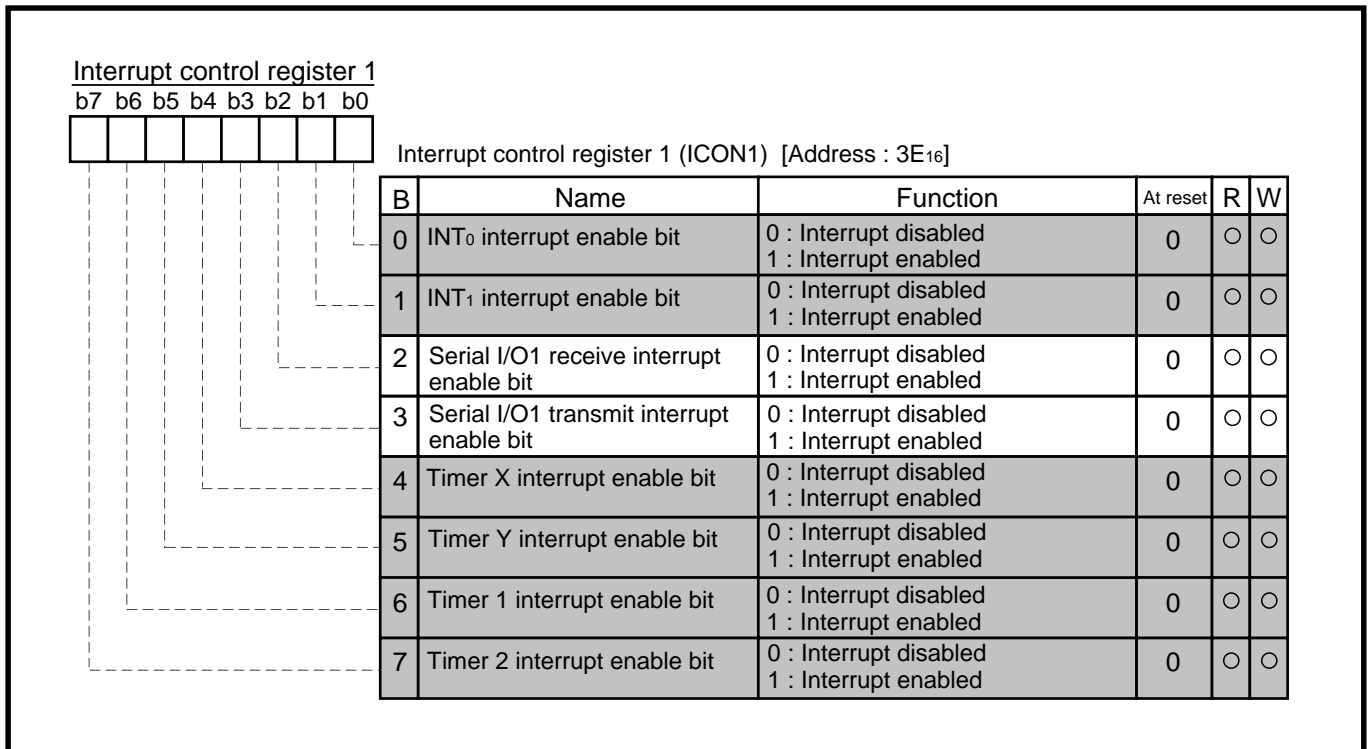

Fig. 2.3.12 Structure of Interrupt control register 1

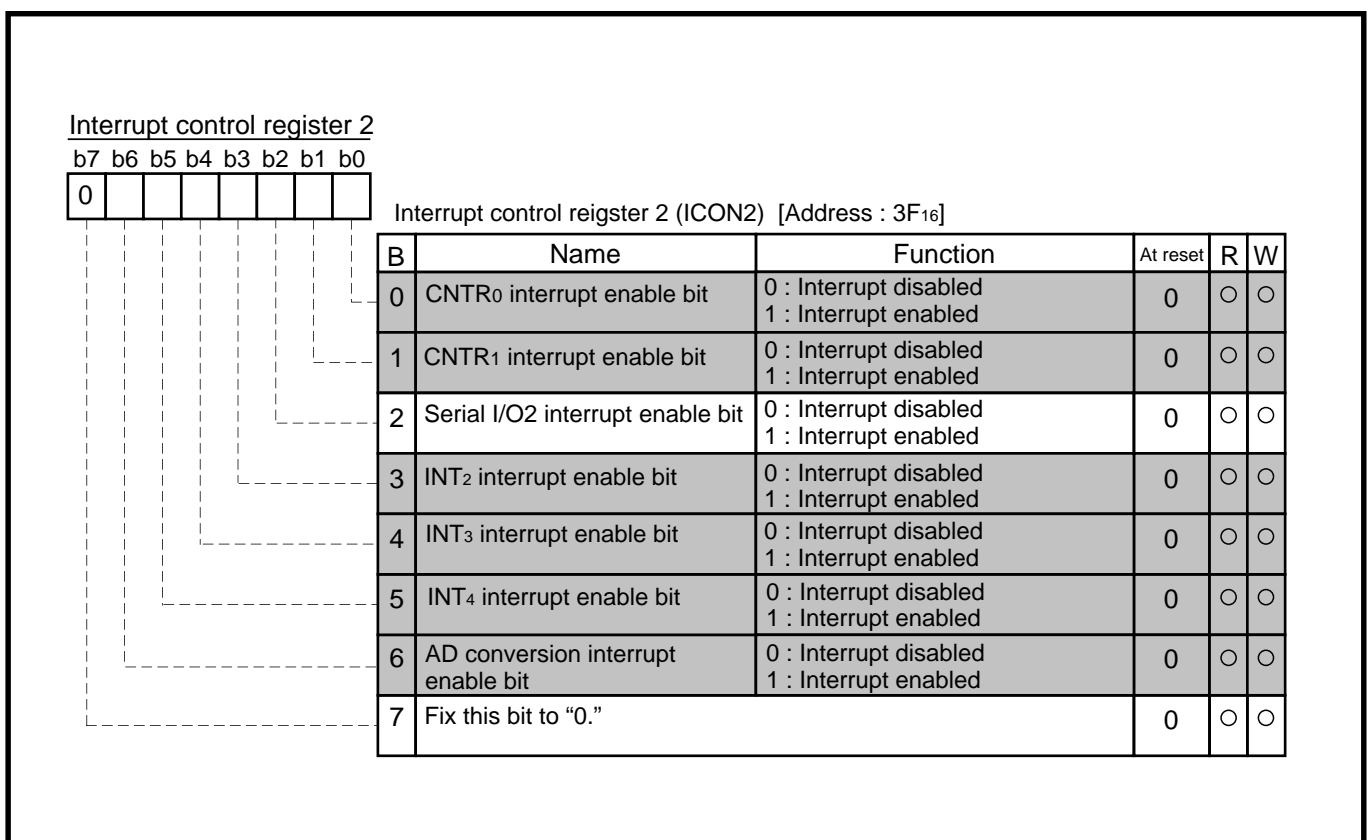

Fig. 2.3.13 Structure of Interrupt control register 2



# APPLICATION

## 2.3 Serial I/O

### 2.3.3 Serial I/O connection examples

#### (1) Control of peripheral IC equipped with CS pin

There are connection examples using a clock synchronous serial I/O mode.

Figure 2.3.14 shows connection examples of a peripheral IC equipped with the CS pin.

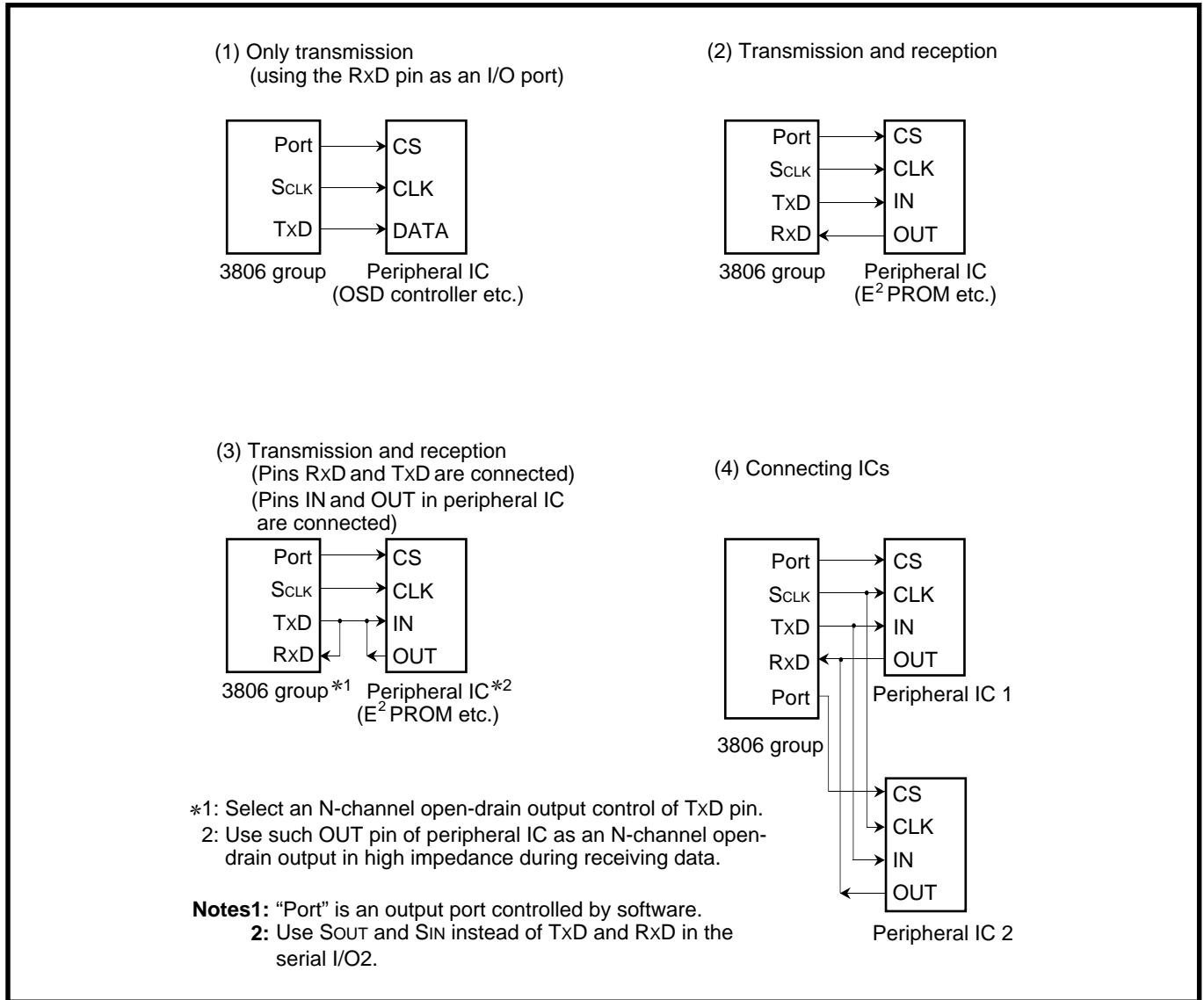

Fig. 2.3.14 Serial I/O connection examples (1)

### (2) Connection with microcomputer

Figure 2.3.15 shows connection examples of the other microcomputers.

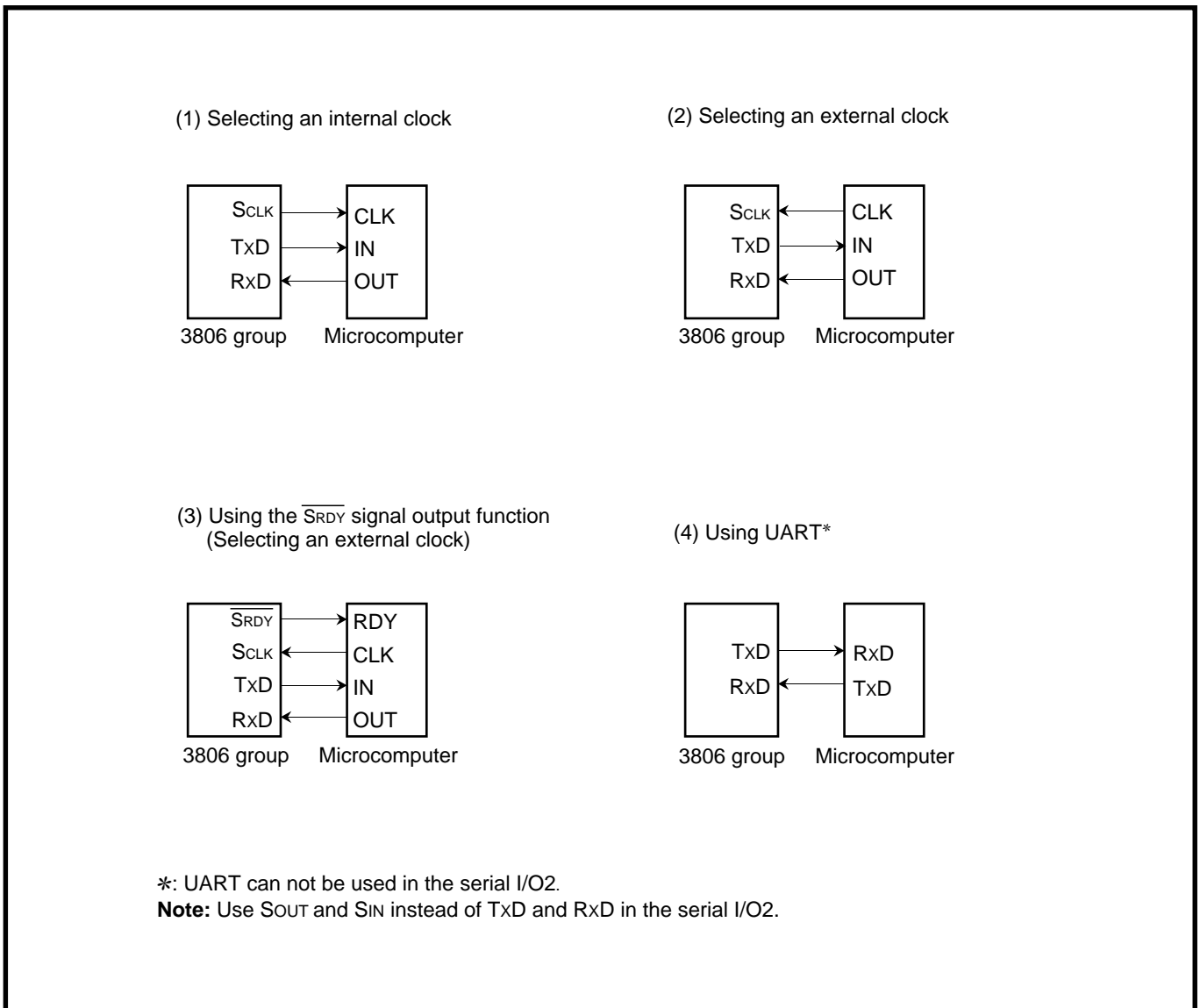

Fig. 2.3.15 Serial I/O connection examples (2)

# APPLICATION

## 2.3 Serial I/O

### 2.3.4 Setting of serial I/O transfer data format

A clock synchronous or clock asynchronous (UART) is selected as a data format of the serial I/O1. The serial I/O2 operates in a clock synchronous.

Figure 2.3.16 shows a setting of serial I/O transfer data format.

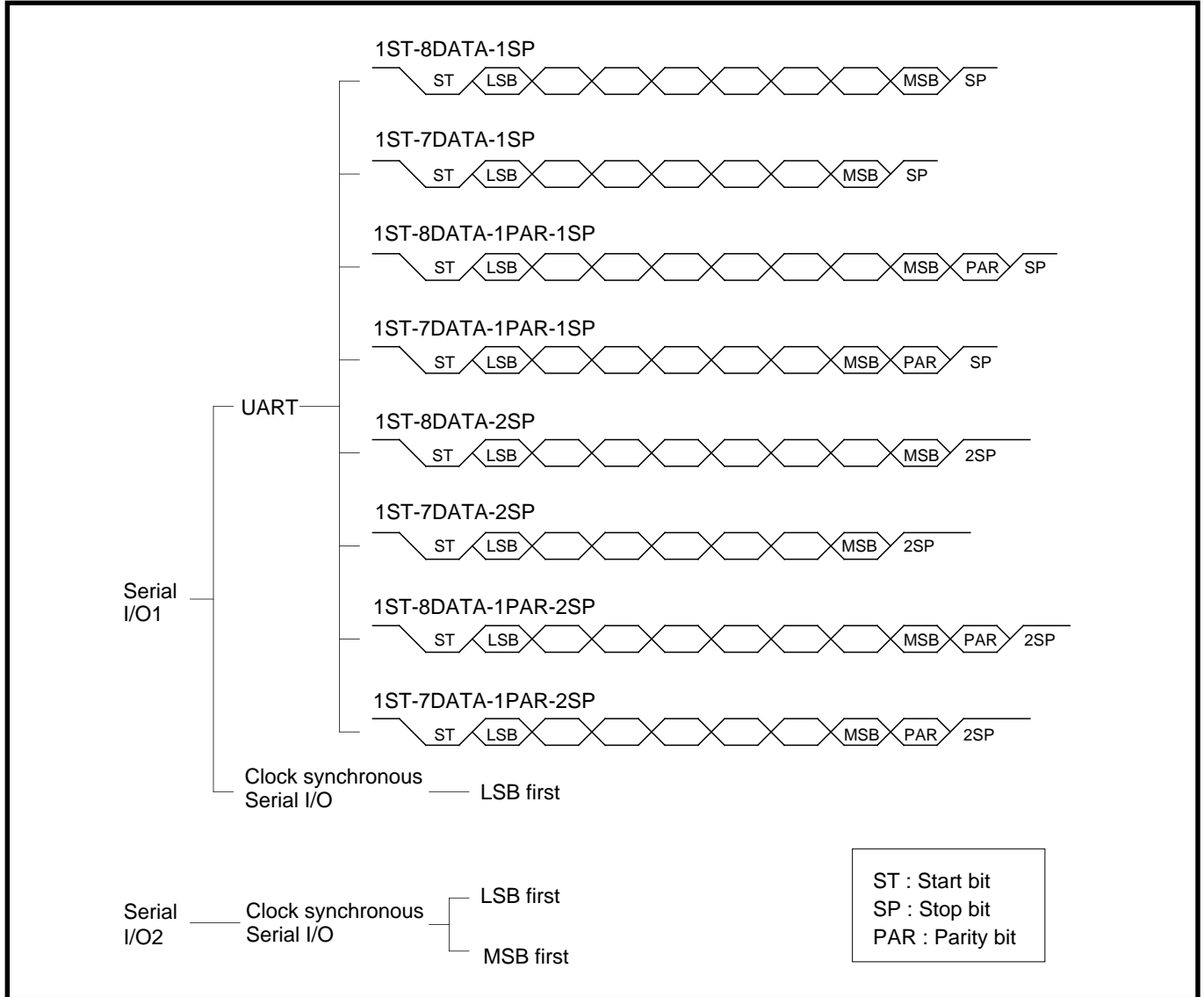

Fig. 2.3.16 Setting of Serial I/O transfer data format

### 2.3.5 Serial I/O application examples

#### (1) Communication using a clock synchronous serial I/O (transmit/receive)

**Outline :** 2-byte data is transmitted and received through the clock synchronous serial I/O. The  $\overline{\text{SRDY}}$  signal is used for communication control.

Figure 2.3.17 shows a connection diagram, and Figure 2.3.18 shows a timing chart.

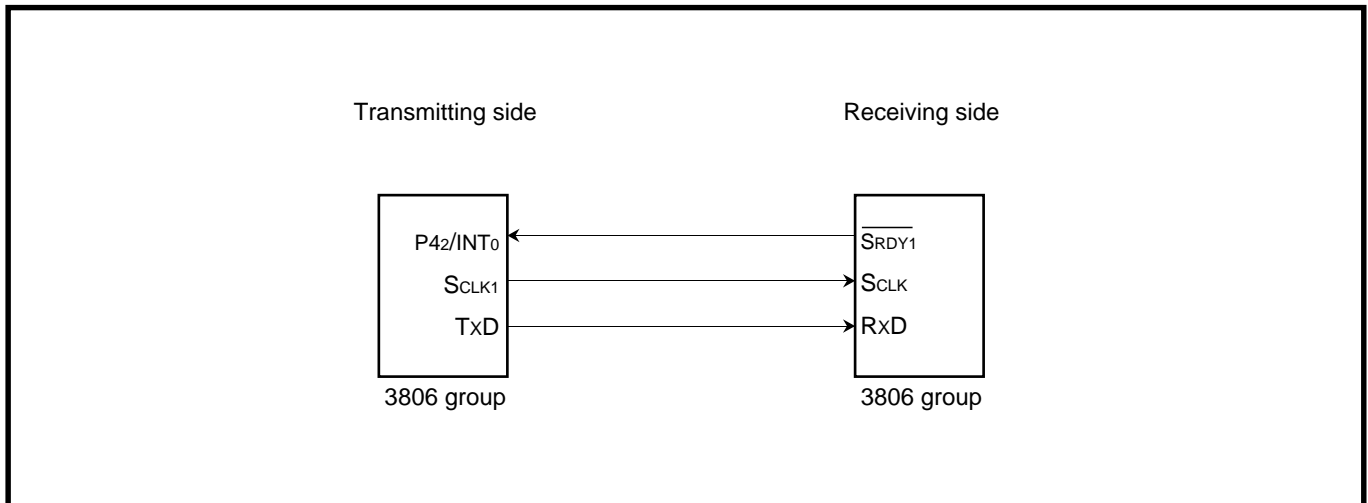

**Fig. 2.3.17 Connection diagram [Communication using a clock synchronous serial I/O]**

- Specifications :**
- The Serial I/O1 is used (clock synchronous serial I/O is selected)
  - Synchronous clock frequency : 125 kHz ( $f(\text{XIN}) = 4 \text{ MHz}$  is divided by 32)
  - The  $\overline{\text{SRDY1}}$  (receivable signal) is used.
  - The receiving side outputs the  $\overline{\text{SRDY1}}$  signal at intervals of 2 ms (generated by timer), and 2-byte data is transferred from the transmitting side to the receiving side.

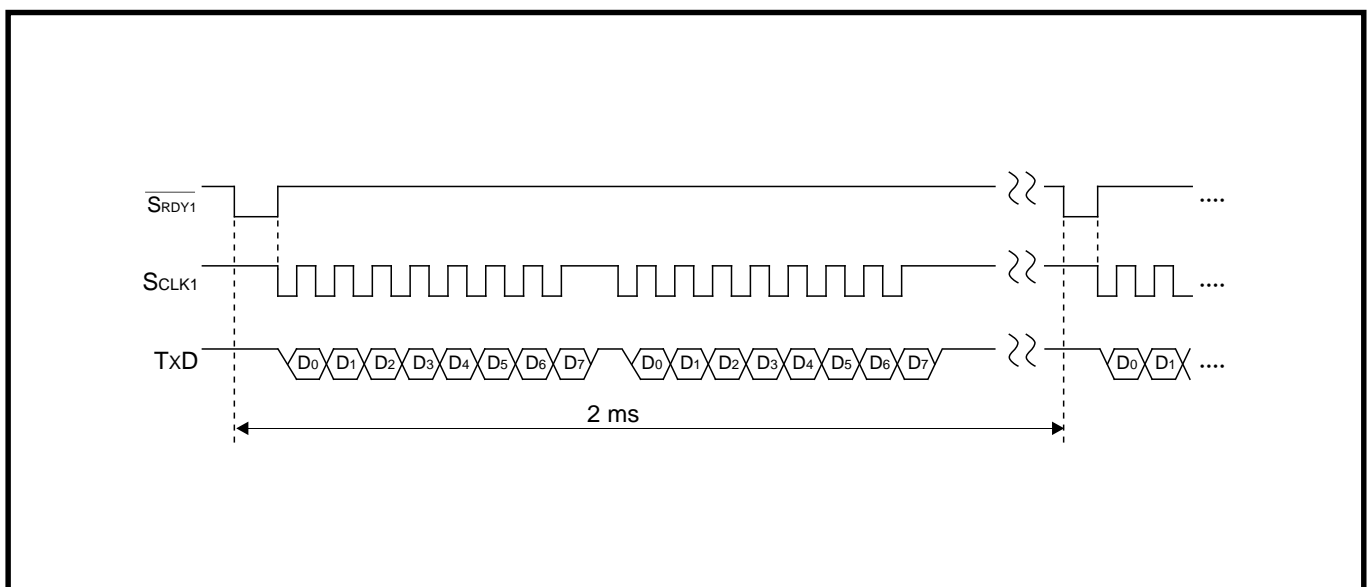

**Fig. 2.3.18 Timing chart [Communication using a clock synchronous serial I/O]**



Receiving side

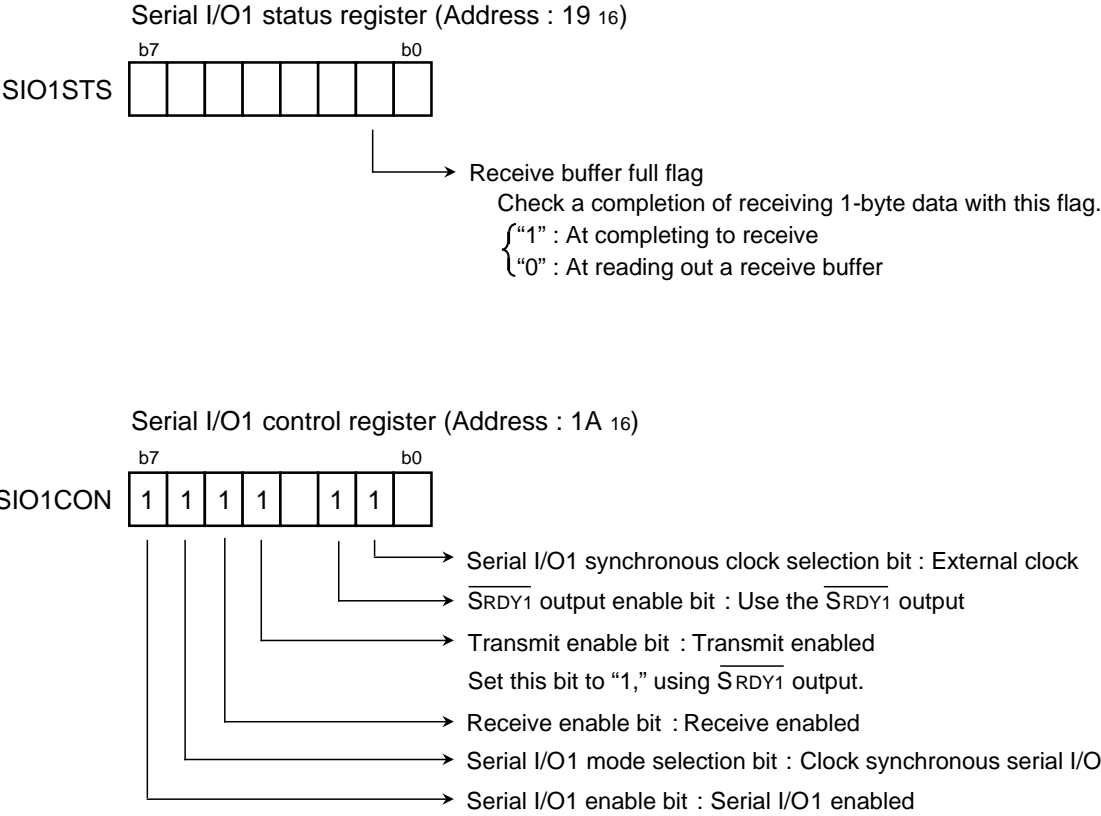
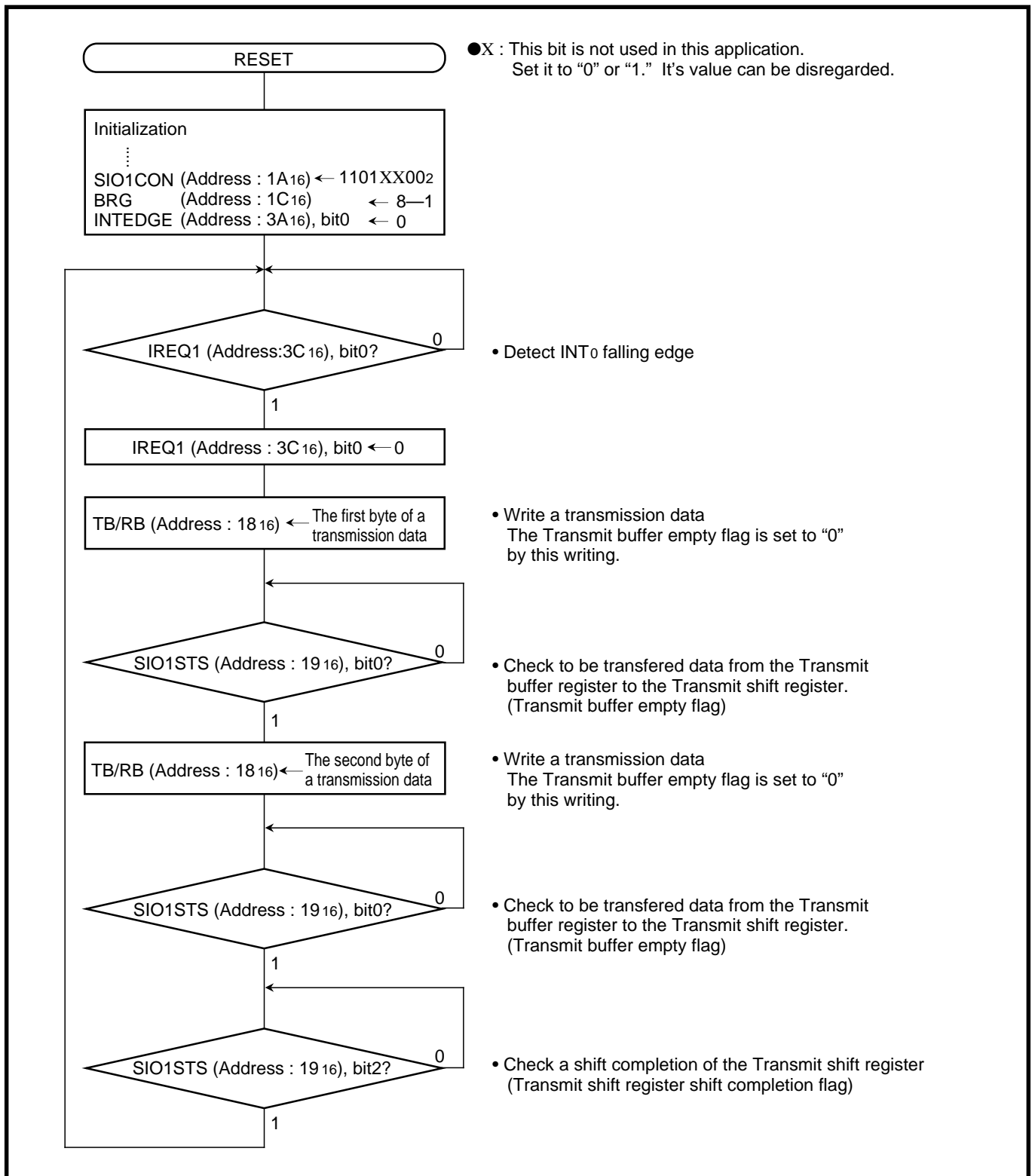

Fig. 2.3.20 Setting of related registers at a receiving side [Communication using a clock synchronous serial I/O]

# APPLICATION

## 2.3 Serial I/O

**Control procedure :** Figure 2.3.21 shows a control procedure at a transmitting side, and Figure 2.3.22 shows a control procedure at a receiving side.



**Fig. 2.3.21 Control procedure at a transmitting side [Communication using a clock synchronous serial I/O]**

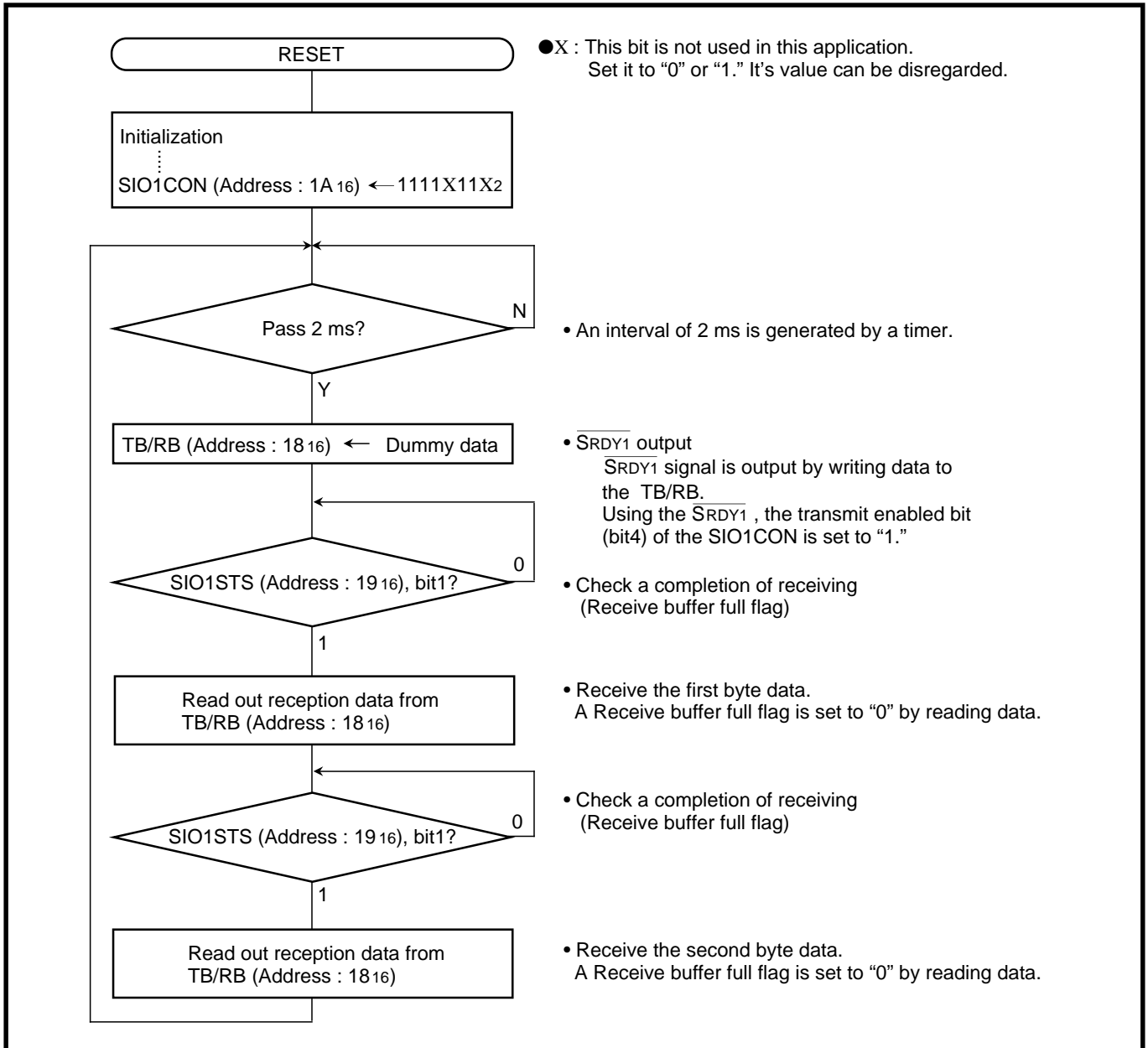

Fig. 2.3.22 Control procedure at a receiving side [Communication using a clock synchronous serial I/O]



# APPLICATION

## 2.3 Serial I/O

### (2) Output of serial data (control of a peripheral IC)

**Outline :** 4-byte data is transmitted and received through the clock synchronous serial I/O. The CS signal is output to a peripheral IC through the port P53.

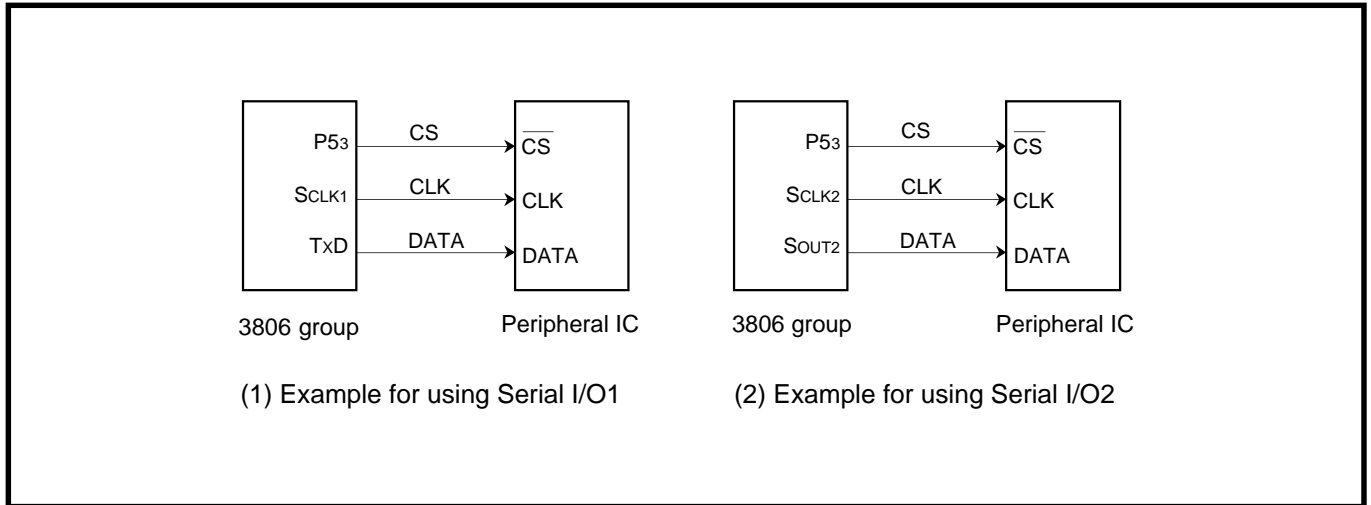

**Fig. 2.3.23 Connection diagram [Output of serial data]**

- Specifications :**
- The Serial I/O is used. (clock synchronous serial I/O is selected)
  - Synchronous clock frequency : 125 kHz ( $f(XIN) = 4 \text{ MHz}$  is divided by 32)
  - Transfer direction : LSB first
  - The Serial I/O1 interrupt is not used.
  - The Port P53 is connected to the  $\overline{CS}$  pin ("L" active) of the peripheral IC for a transmission control (the output level of the port P53 is controlled by software).

Figure 2.3.24 shows an output timing chart of serial data.

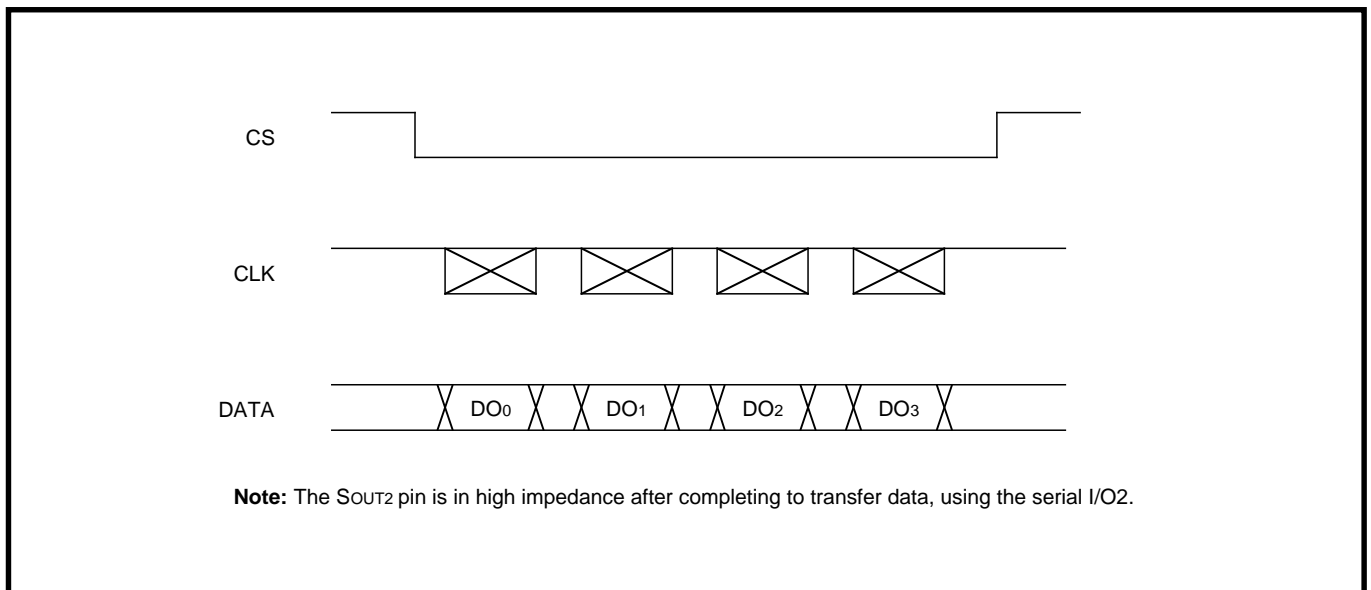

**Fig. 2.3.24 Timing chart [Output of serial data]**

Figure 2.3.25 shows a setting of serial I/O1 related registers, and Figure 2.3.26 shows a setting of serial I/O1 transmission data.

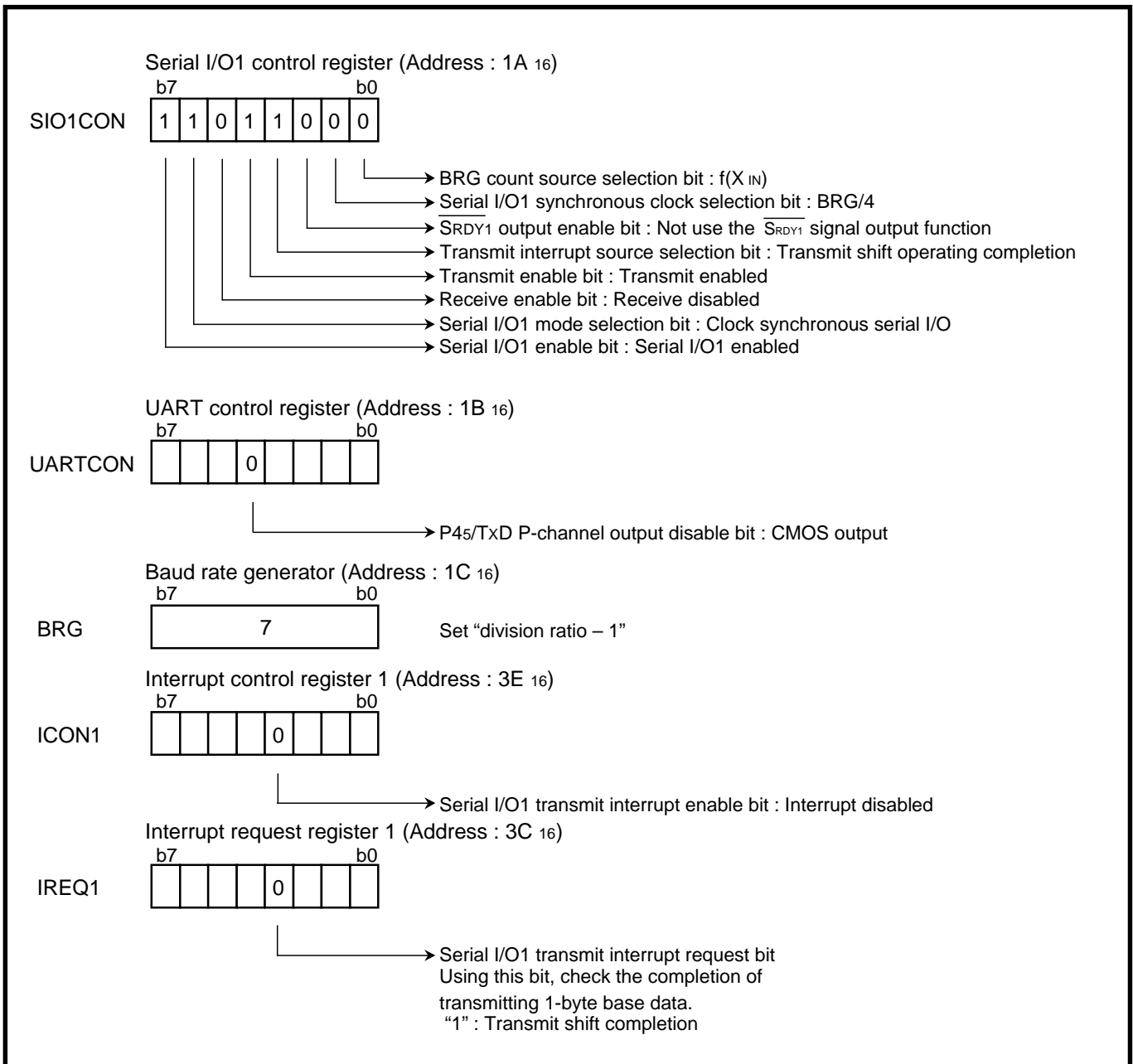

Fig. 2.3.25 Setting of serial I/O1 related registers [Output of serial data]

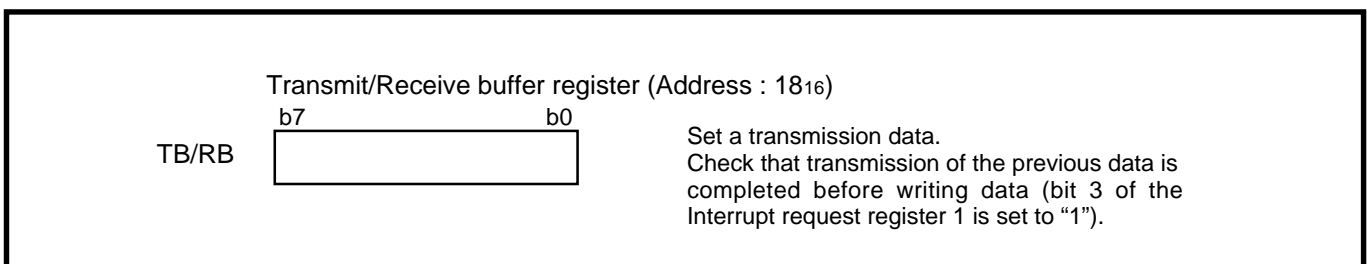

Fig. 2.3.26 Setting of serial I/O1 transmission data [Output of serial data]

# APPLICATION

## 2.3 Serial I/O

**Control procedure :** When the registers are set as shown in Fig. 2.3.25, the Serial I/O1 can transmit 1-byte data simply by writing data to the Transmit buffer register. Thus, after setting the CS signal to "L," write the transmission data to the Receive buffer register on a 1-byte base, and return the CS signal to "H" when the desired number of bytes have been transmitted.

Figure 2.3.27 shows a control procedure of serial I/O1.

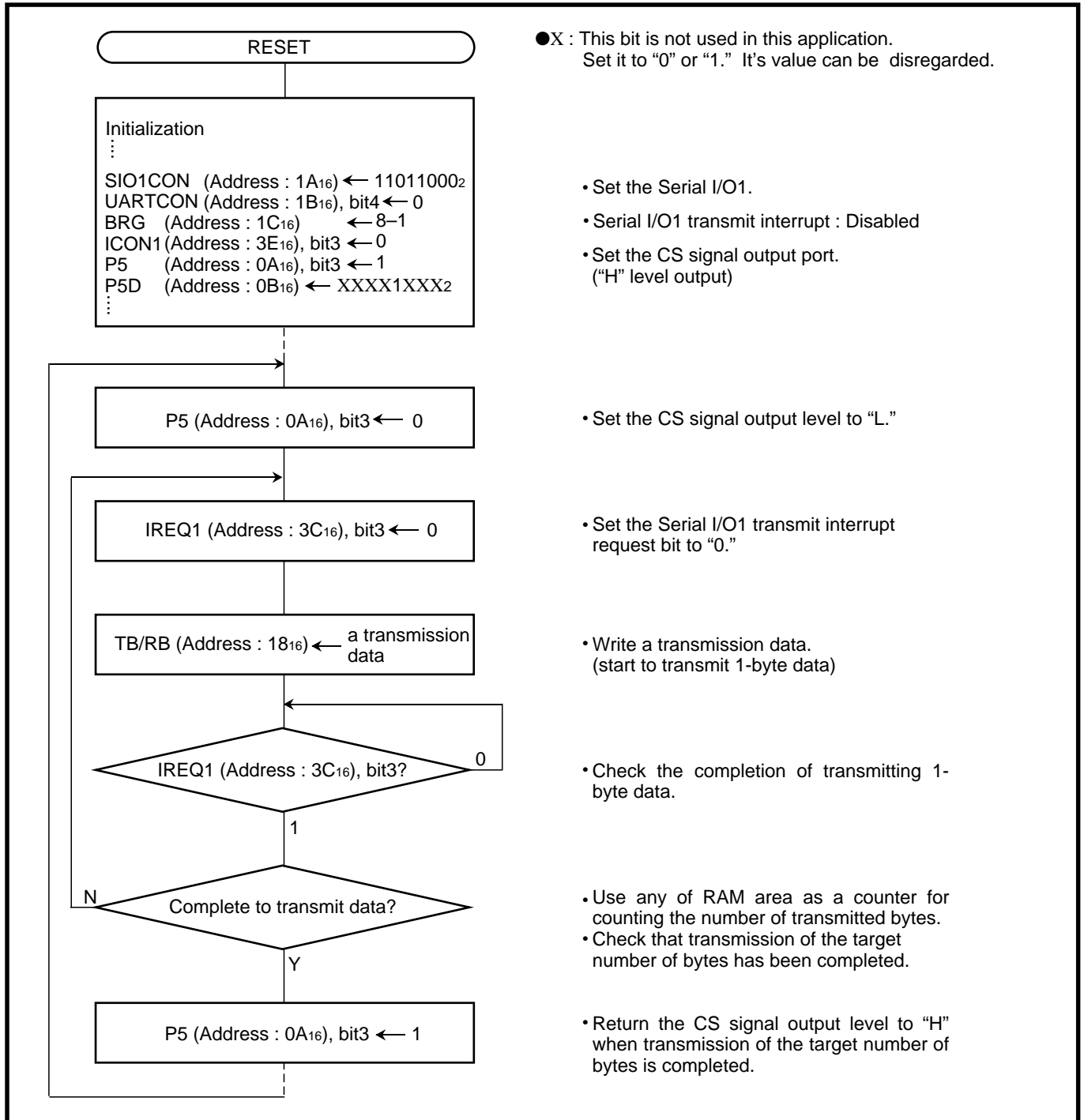

Fig. 2.3.27 Control procedure of serial I/O1 [Output of serial data]

Figure 2.3.28 shows a setting of serial I/O2 related registers, and Figure 2.3.29 shows a setting of serial I/O2 transmission data.

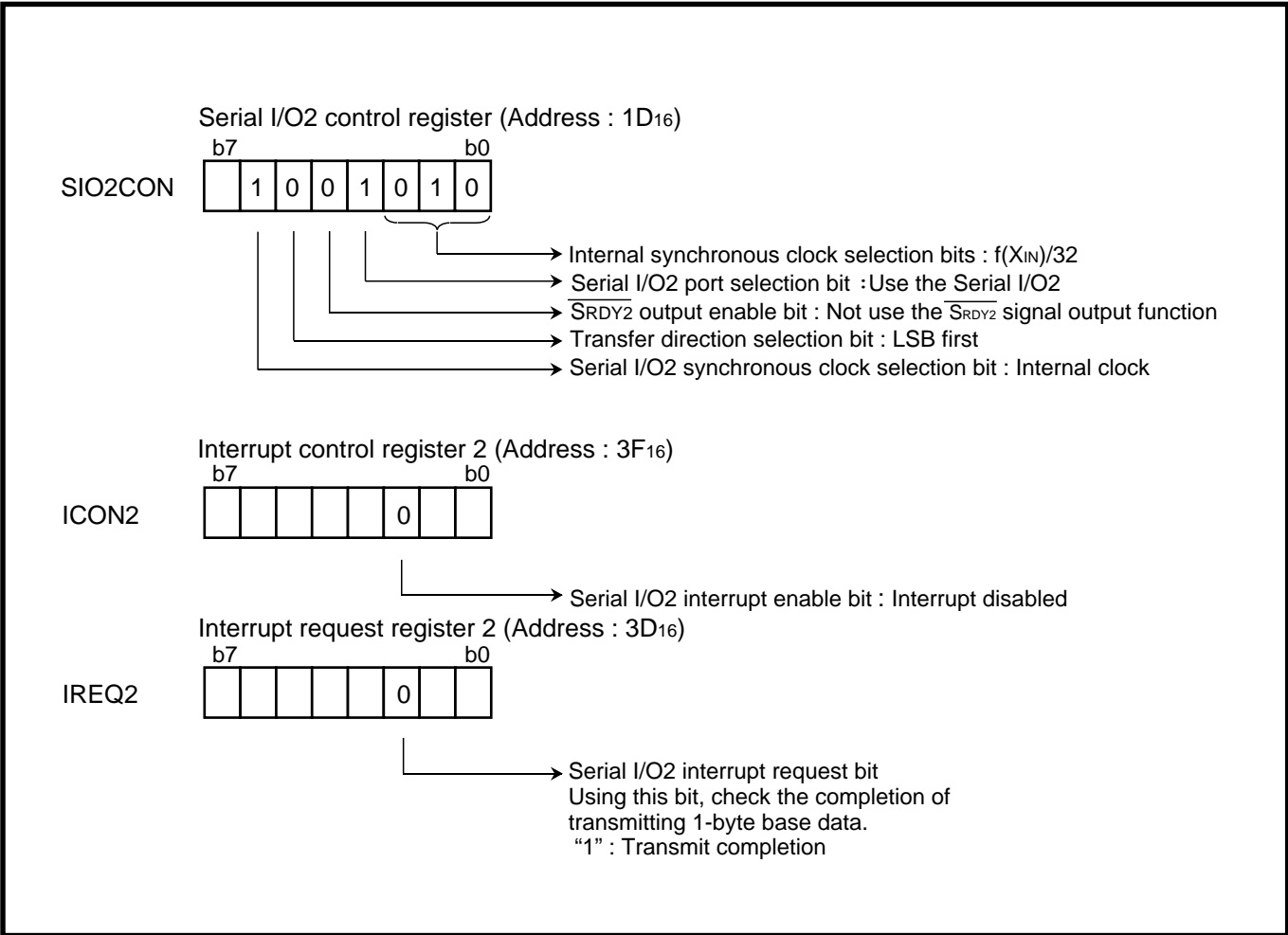

Fig. 2.3.28 Setting of serial I/O2 related registers [Output of serial data]

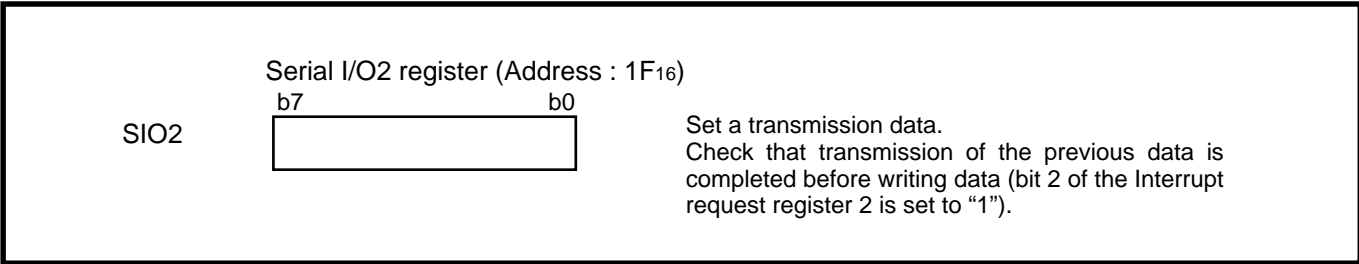

Fig. 2.3.29 Setting of serial I/O2 transmission data [Output of serial data]

# APPLICATION

## 2.3 Serial I/O

**Control procedure :** When the registers are set as shown in Fig. 2.3.28, the Serial I/O2 can transmit 1-byte data simply by writing data to the Serial I/O2 register. Thus, after setting the CS signal to “L,” write the transmission data to the Serial I/O1 register on a 1-byte base, and return the CS signal to “H” when the desired number of bytes have been transmitted.

Figure 2.3.30 shows a control procedure of serial I/O2.

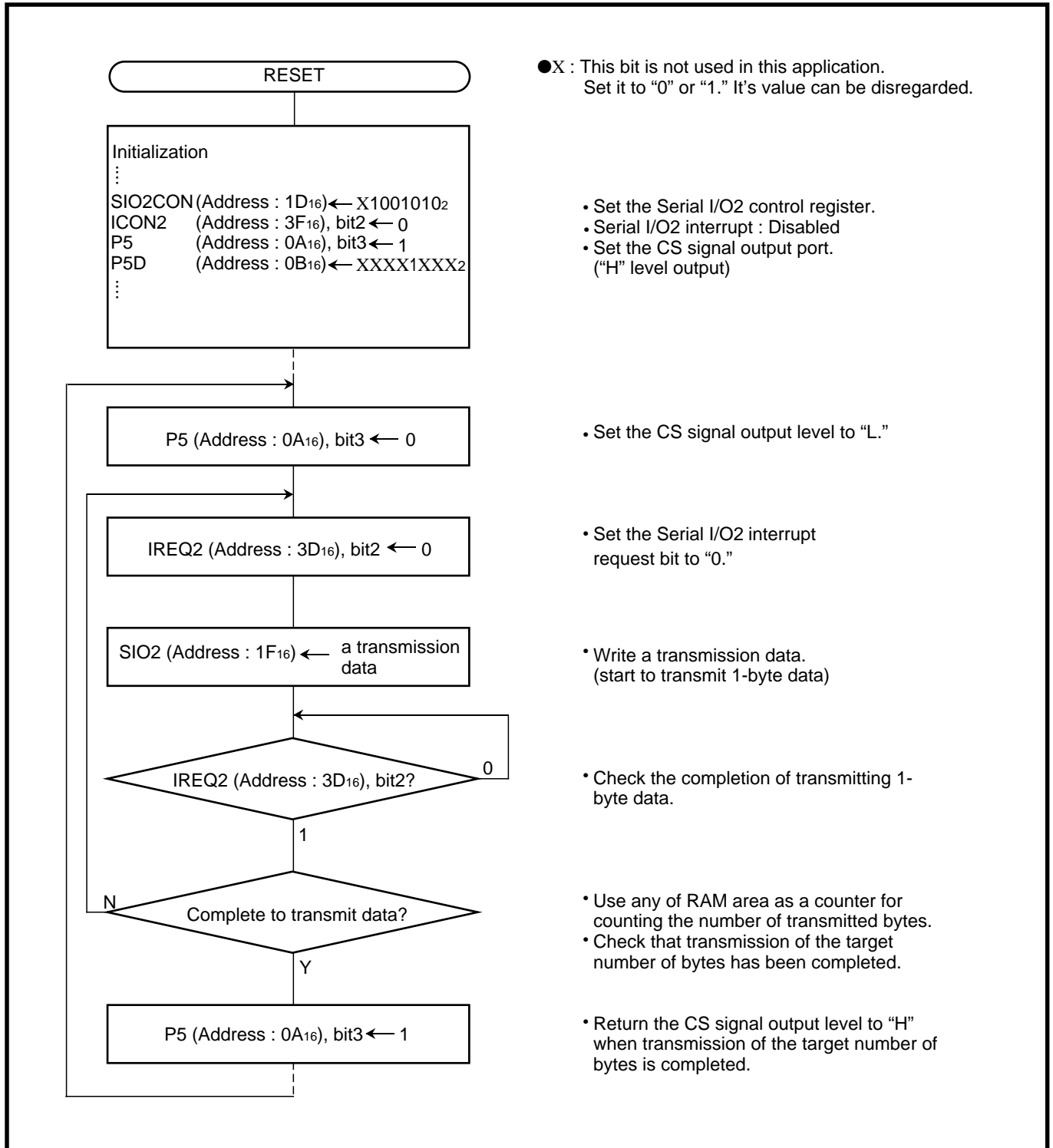
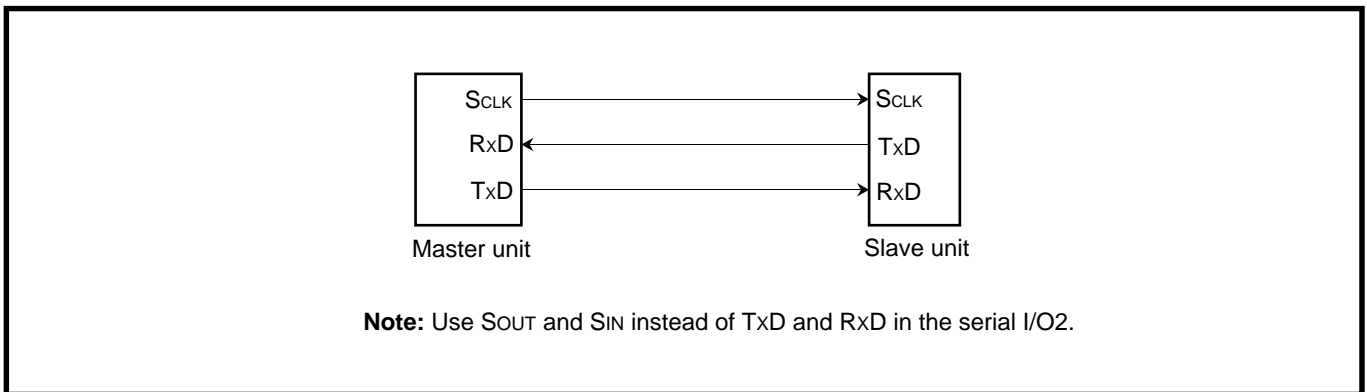

Fig. 2.3.30 Control procedure of serial I/O2 [Output of serial data]

**(3) Cyclic transmission or reception of block data (data of a specified number of bytes) between microcomputers [without using an automatic transfer]**

**Outline :** When a clock synchronous serial I/O is used for communication, synchronization of the clock and the data between the transmitting and receiving sides may be lost because of noise included in the synchronizing clock. Thus, it is necessary to be corrected constantly. This “heading adjustment” is carried out by using the interval between blocks in this example.



**Fig. 2.3.31 Connection diagram [Cyclic transmission or reception of block data between microcomputers]**

- Specifications :**
- The serial I/O1 is used (clock synchronous serial I/O is selected).
  - Synchronous clock frequency : 131 kHz ( $f(XIN) = 4.19 \text{ MHz}$  is divided by 32)
  - Byte cycle: 488  $\mu\text{s}$
  - Number of bytes for transmission or reception : 8 byte/block
  - Block transfer cycle : 16 ms
  - Block transfer period : 3.5 ms
  - Interval between blocks : 12.5 ms
  - Heading adjustive time : 8 ms

**Limitations of the specifications**

1. Reading of the reception data and setting of the next transmission data must be completed within the time obtained from “byte cycle – time for transferring 1-byte data” (in this example, the time taken from generating of the Serial I/O1 receive interrupt request to generating of the next synchronizing clock is 431  $\mu\text{s}$ ).
2. “Heading adjustive time < interval between blocks” must be satisfied.

# APPLICATION

## 2.3 Serial I/O

The communication is performed according to the timing shown below. In the slave unit, when a synchronizing clock is not input within a certain time (heading adjustive time), the next clock input is processed as the beginning (heading) of a block.

When a clock is input again after one block (8 byte) is received, the clock is ignored.

Figure 2.3.33 shows a setting of related registers.

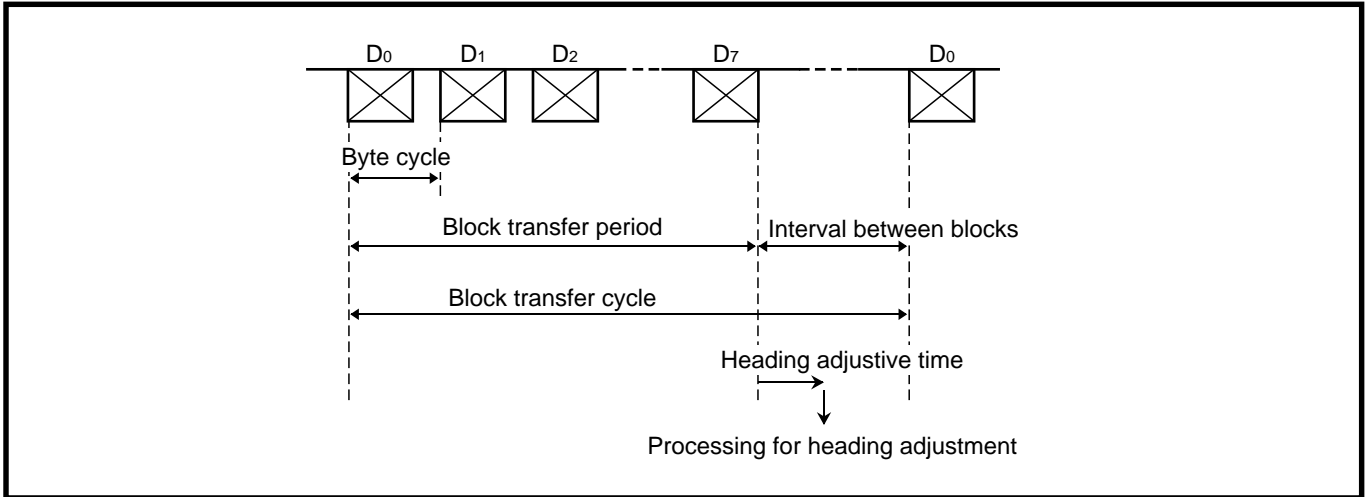

Fig. 2.3.32 Timing chart [Cyclic transmission or reception of block data between microcomputers]

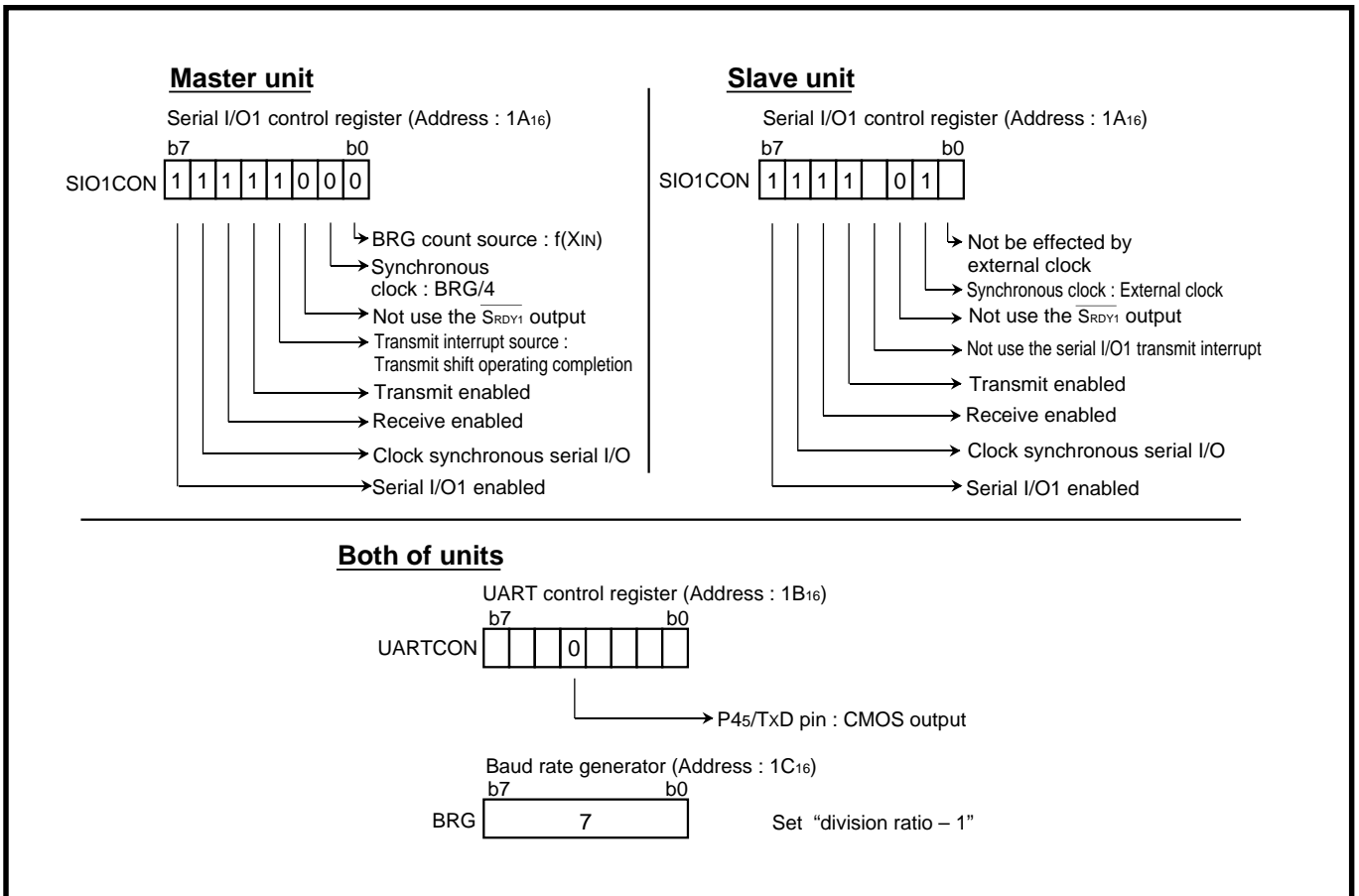

Fig. 2.3.33 Setting of related registers [Cyclic transmission or reception of block data between microcomputers]

### Control procedure :

#### ① Control in the master unit

After a setting of the related registers is completed as shown in Figure 2.3.33, in the master unit transmission or reception of 1-byte data is started simply by writing transmission data to the Transmit buffer register.

To perform the communication in the timing shown in Figure 2.3.32, therefore, take the timing into account and write transmission data. Read out the reception data when the Serial I/O1 transmit interrupt request bit is set to "1," or before the next transmission data is written to the Transmit buffer register.

A processing example in the master unit using timer interrupts is shown below.

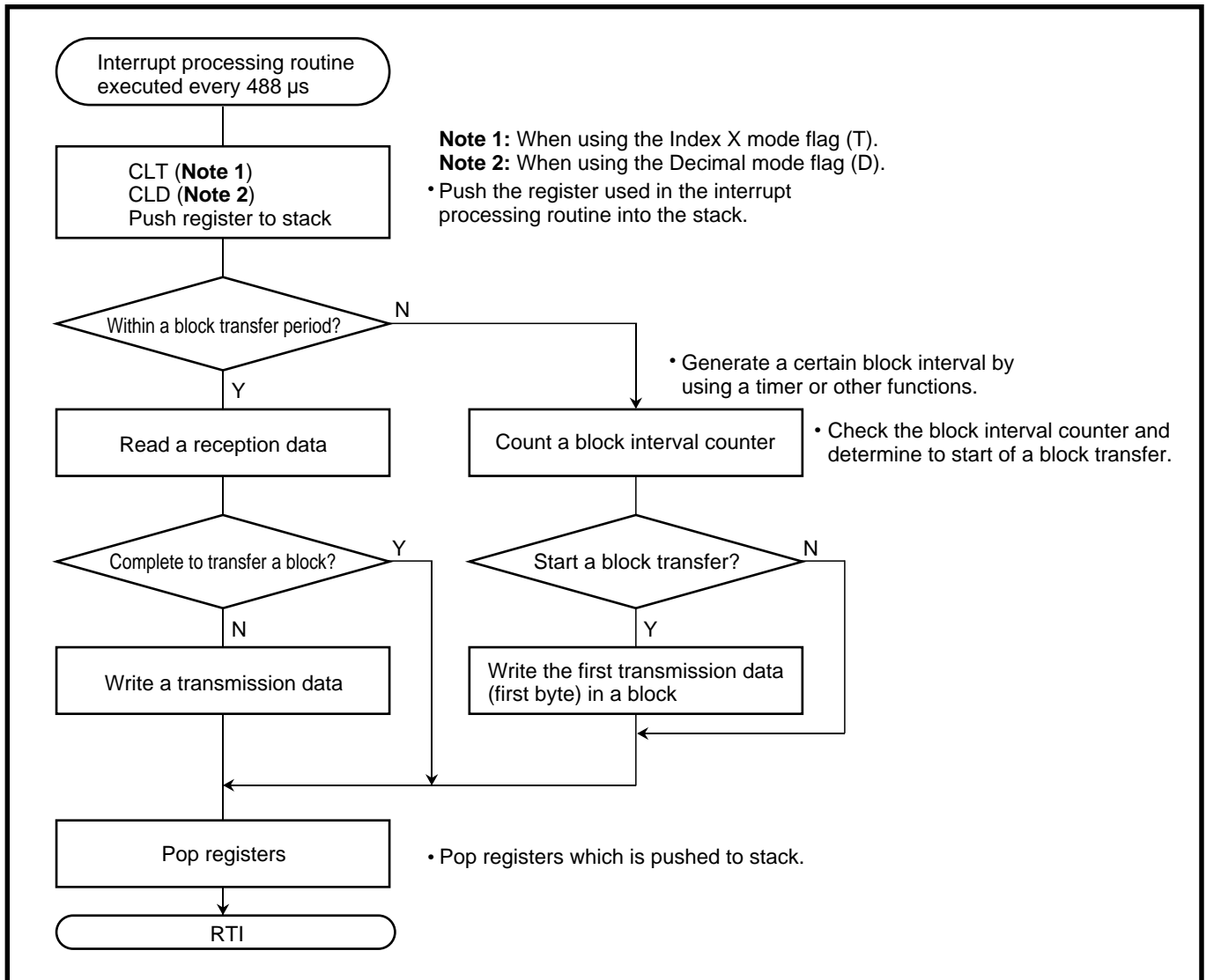

Fig. 2.3.34 Control in the master unit



# APPLICATION

## 2.3 Serial I/O

### ② Control in the slave unit

After a setting of the related registers is completed as shown in Figure 2.3.33, the slave unit becomes the state which is received a synchronizing clock at all times, and the Serial I/O1 receive interrupt request bit is set to "1" every time an 8-bit synchronous clock is received.

By the serial I/O1 receive interrupt processing routine, the data to be transmitted next is written to the Transmit buffer register after received data is read out.

However, if no serial I/O1 receive interrupt occurs for more than a certain time (head adjustive time), the following processing will be performed.

1. The first 1 byte data of the transmission data in the block is written into the Transmission buffer register.
2. The data to be received next is processed as the first 1 byte of the received data in the block.

Figure 2.3.35 shows the control in the slave unit using a serial I/O1 receive interrupt and any timer interrupt (for head adjustive).

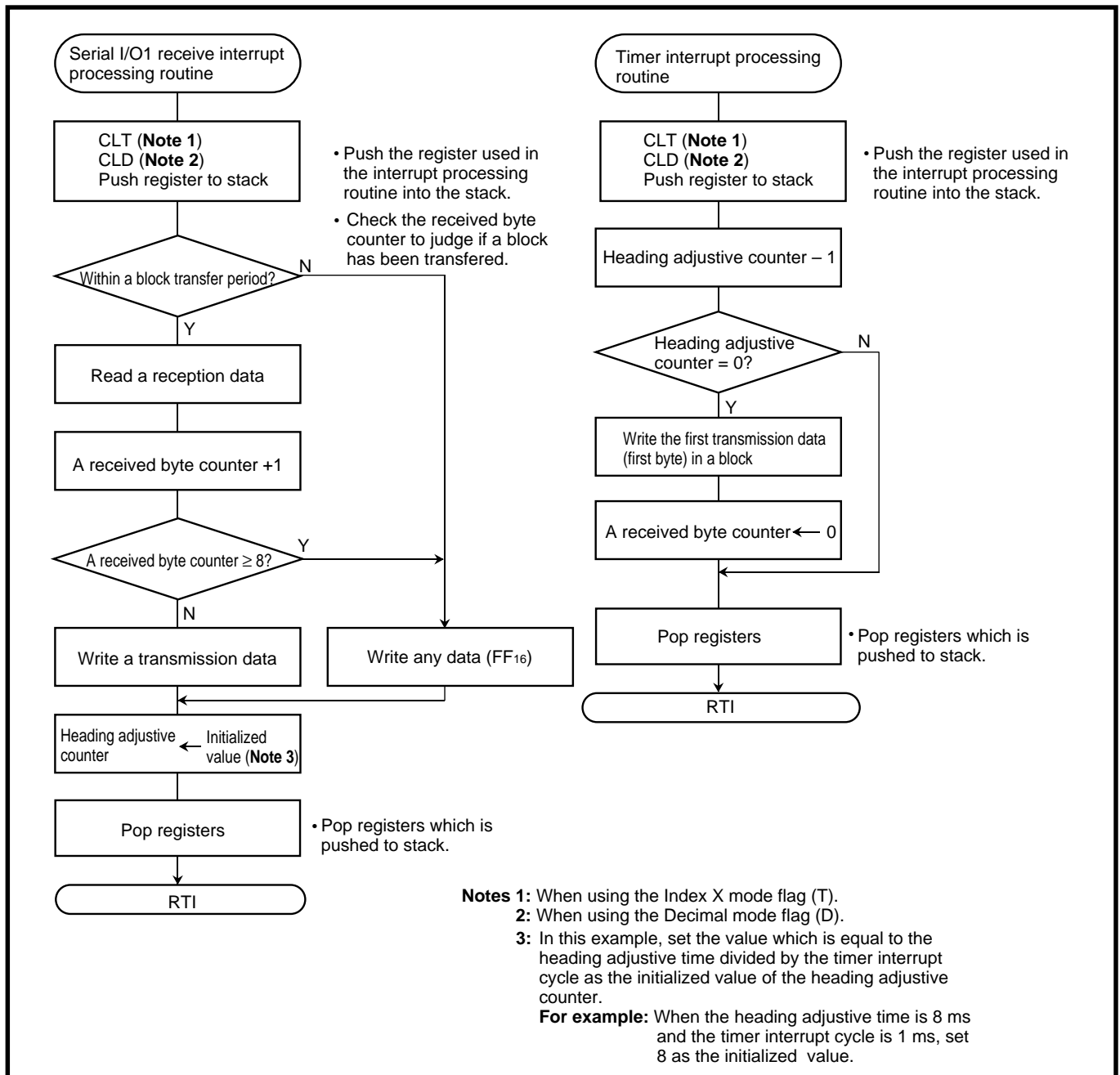
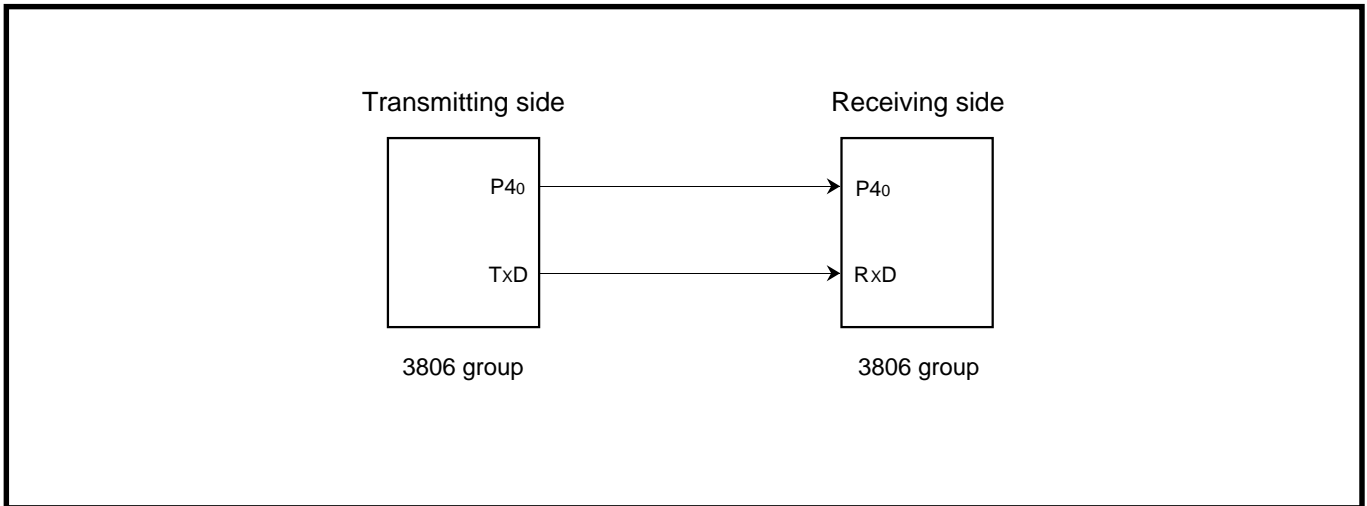

Fig. 2.3.35 Control in the slave unit

### (4) Communication (transmit/receive) using an asynchronous serial I/O (UART)

**Point :** 2-byte data is transmitted and received through an asynchronous serial I/O.  
The port P40 is used for communication control.

Figure 2.3.36 shows a connection diagram, and Figure 2.3.37 shows a timing chart.



**Fig. 2.3.36** Connection diagram [Communication using UART]

- Specifications :**
- The Serial I/O1 is used (UART is selected).
  - Transfer bit rate : 9600 bps ( $f(XIN) = 4.9152 \text{ MHz}$  is divided by 512)
  - Communication control using port P40  
(The output level of the port P40 is controlled by software.)
  - 2-byte data is transferred from the transmitting side to the receiving side at intervals of 10 ms (generated by timer).

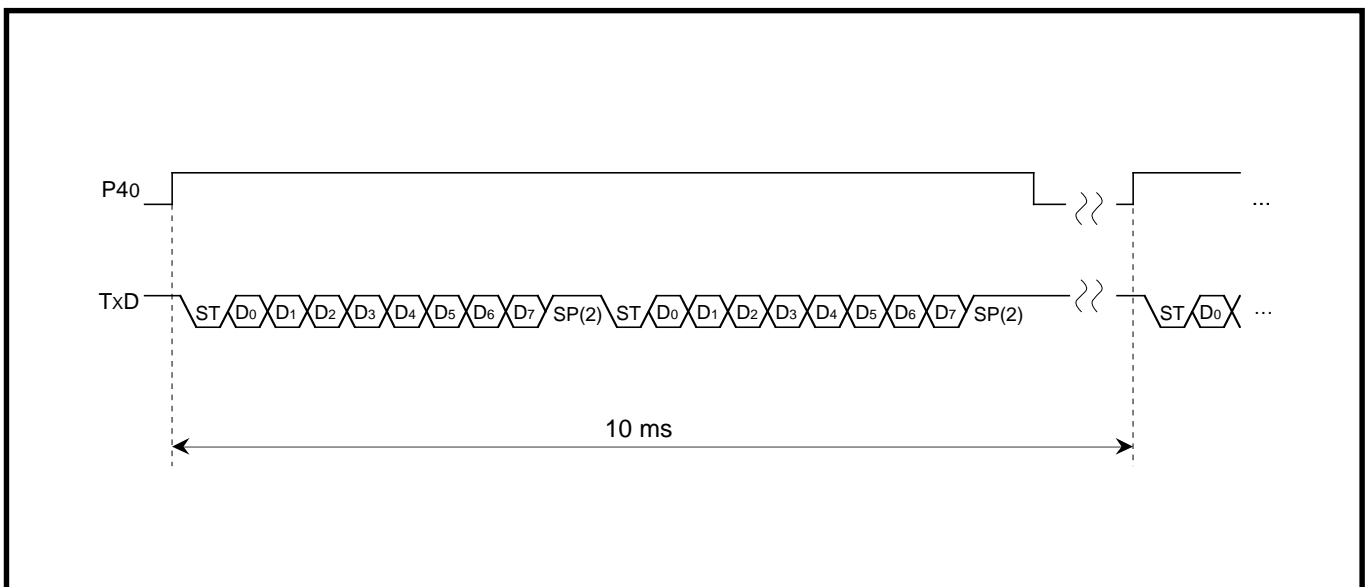

**Fig. 2.3.37** Timing chart [Communication using UART]

# APPLICATION

## 2.3 Serial I/O

Table 2.3.1 shows setting examples of Baud rate generator (BRG) values and transfer bit rate values, Figure 2.3.38 shows a setting of related registers at a transmitting side, and Figure 2.3.39 shows a setting of related registers at a receiving side.

**Table 2.3.1 Setting examples of Baud rate generator values and transfer bit rate values**

Transfer bit rate (bps) (Note 1)	BRG count source (Note 2)	at f(XIN) = 4.9152 MHz		at f(XIN) = 7.3728 MHz		at f(XIN) = 8 MHz	
		BRG setting value	Actual time (bps)	BRG setting value	Actual time (bps)	BRG setting value	Actual time (bps)
600	f(XIN)/4	127(7F <sub>16</sub> )	600.00	191(BF <sub>16</sub> )	600.00	207(CF <sub>16</sub> )	600.96
1200	f(XIN)/4	63(3F <sub>16</sub> )	1200.00	95(5F <sub>16</sub> )	1200.00	103(67 <sub>16</sub> )	1201.92
2400	f(XIN)/4	31(1F <sub>16</sub> )	2400.00	47(2F <sub>16</sub> )	2400.00	51(33 <sub>16</sub> )	2403.85
4800	f(XIN)/4	15(0F <sub>16</sub> )	4800.00	23(17 <sub>16</sub> )	4800.00	25(19 <sub>16</sub> )	4807.69
9600	f(XIN)/4	7(07 <sub>16</sub> )	9600.00	11(0B <sub>16</sub> )	9600.00	12(0C <sub>16</sub> )	9615.38
19200	f(XIN)/4	3(03 <sub>16</sub> )	19200.00	5(05 <sub>16</sub> )	19200.00	5(05 <sub>16</sub> )	20833.33
38400	f(XIN)/4	1(01 <sub>16</sub> )	38400.00	2(02 <sub>16</sub> )	38400.00	2(02 <sub>16</sub> )	41666.67
76800	f(XIN)	3(03 <sub>16</sub> )	76800.00	5(05 <sub>16</sub> )	76800.00	5(05 <sub>16</sub> )	83333.33
31250	f(XIN)	_____	_____	_____	_____	15(0F <sub>16</sub> )	31250.00
62500	f(XIN)	_____	_____	_____	_____	7(07 <sub>16</sub> )	62500.00

**Notes 1:** Equation of transfer bit rate

$$\text{Transfer bit rate (bps)} = \frac{f(\text{XIN})}{(\text{BRG setting value} + 1) \times 16 \times m}$$

m: when bit 0 of the Serial I/O1 control register (Address : 1A<sub>16</sub>) is set to "0," a value of m is 1.  
when bit 0 of the Serial I/O1 control register (Address : 1A<sub>16</sub>) is set to "1," a value of m is 4.

**2:** A BRG count source is selected by bit 0 of the Serial I/O1 control register (Address : 1A<sub>16</sub>).



# APPLICATION

## 2.3 Serial I/O

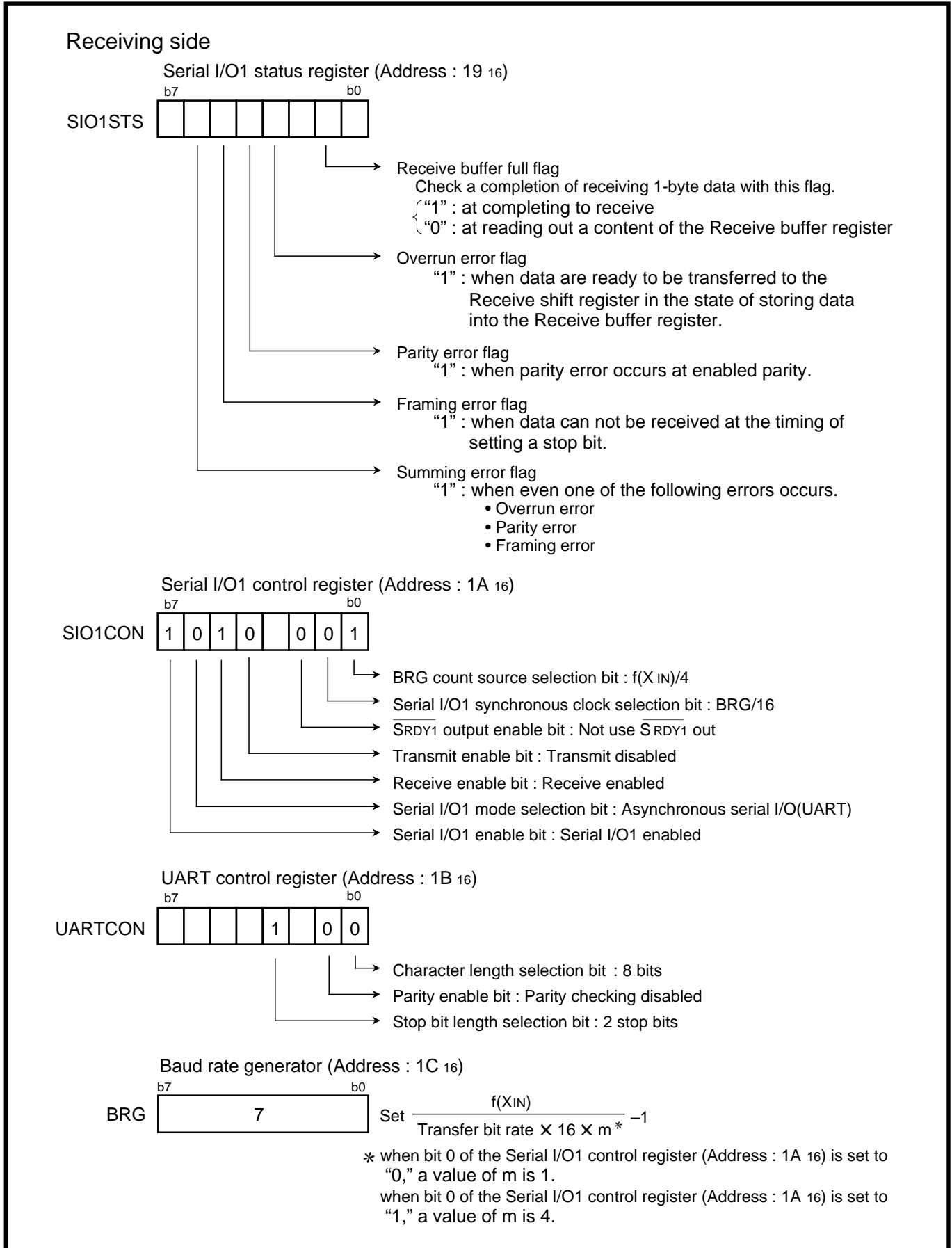
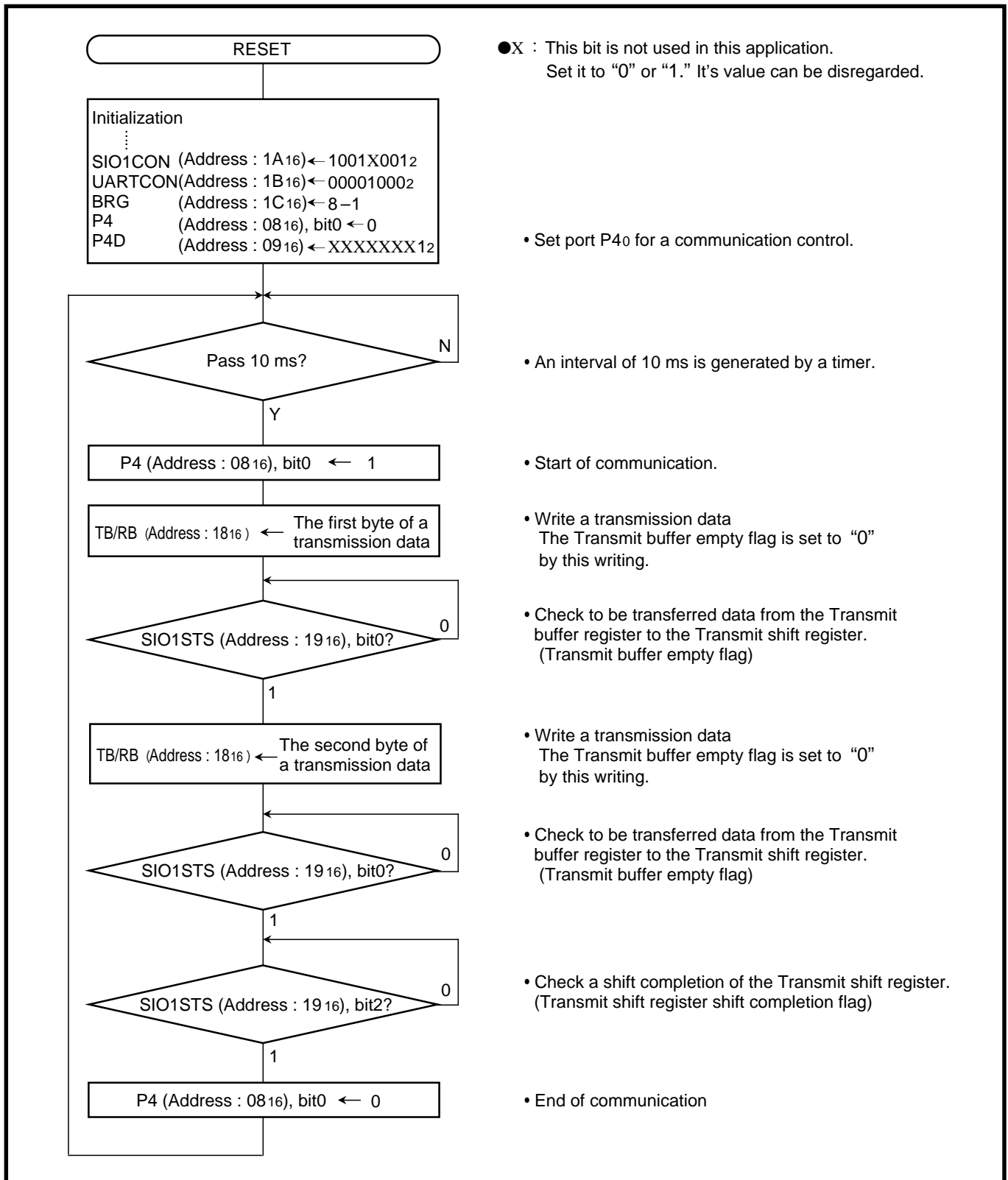

Fig. 2.3.39 Setting of related registers at a receiving side [Communication using UART]

**Control procedure :** Figure 2.3.40 shows a control procedure at a transmitting side, and Figure 2.3.41 shows a control procedure at a receiving side.



**Fig. 2.3.40 Control procedure at a transmitting side [Communication using UART]**

# APPLICATION

## 2.3 Serial I/O

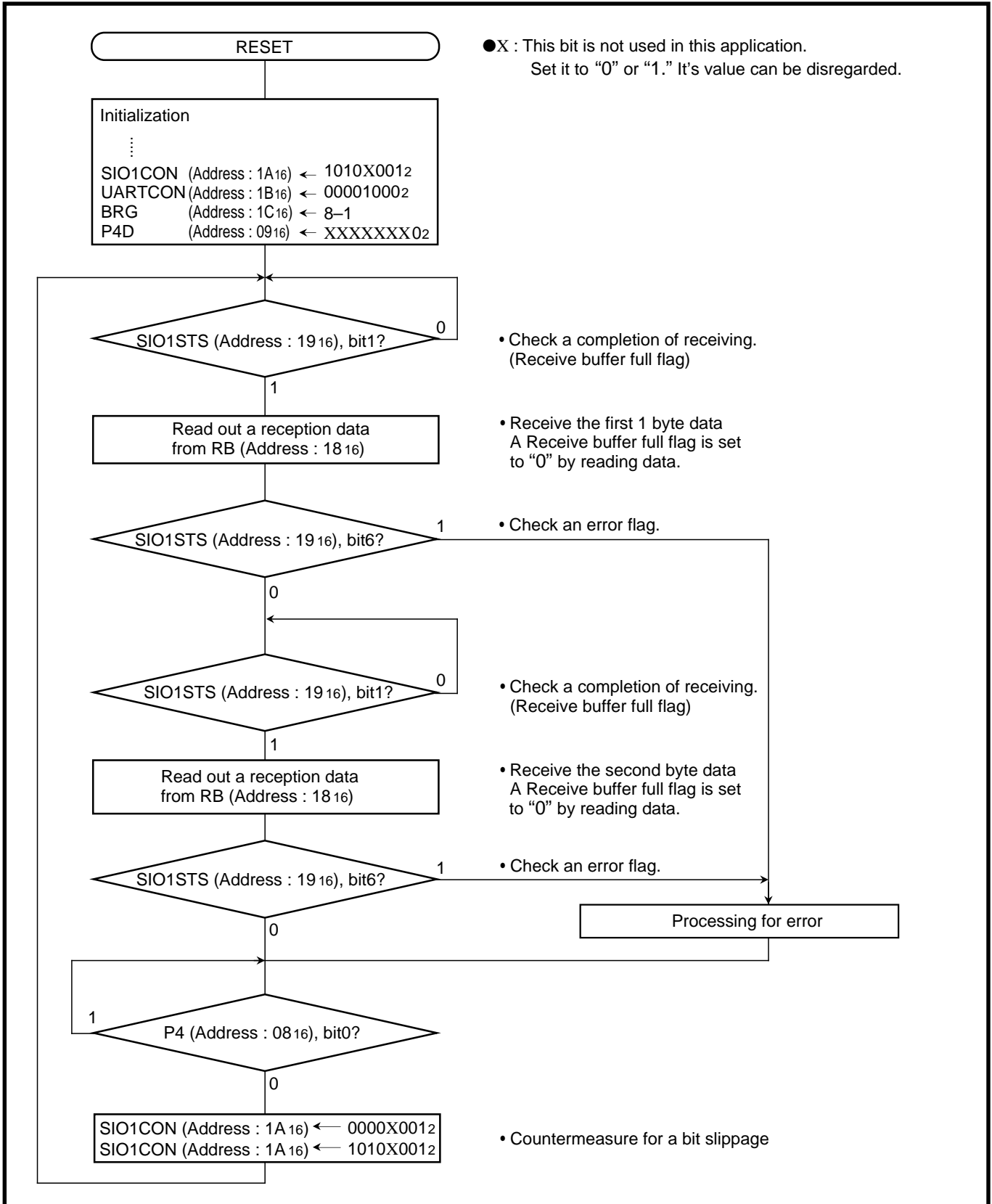
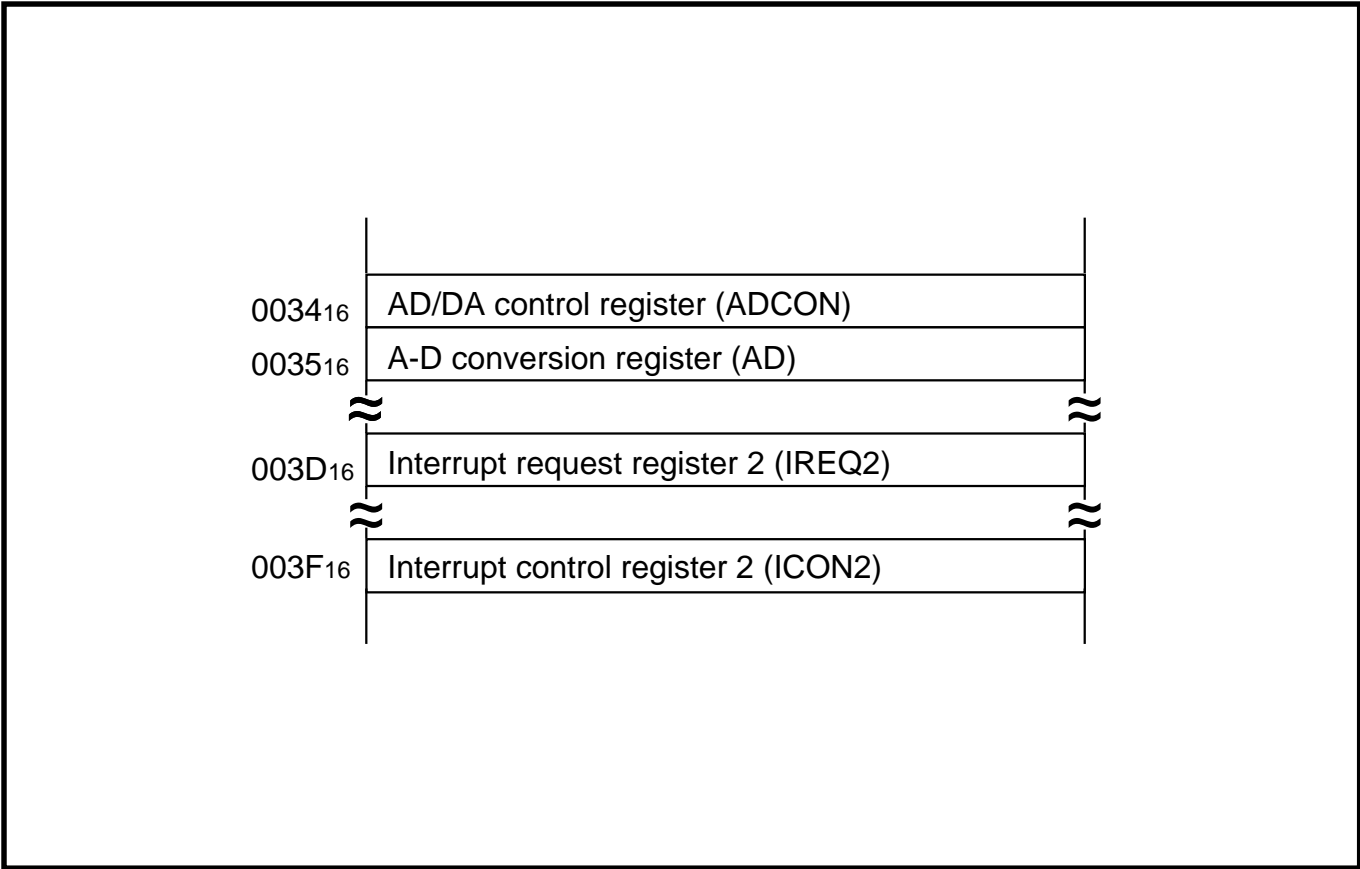

Fig. 2.3.41 Control procedure at a receiving side [Communication using UART]

**2.4 A-D converter**

**2.4.1 Memory map of A-D conversion**



**Fig. 2.4.1 Memory map of A-D conversion related registers**



# APPLICATION

## 2.4 A-D converter

### 2.4.2 Related registers

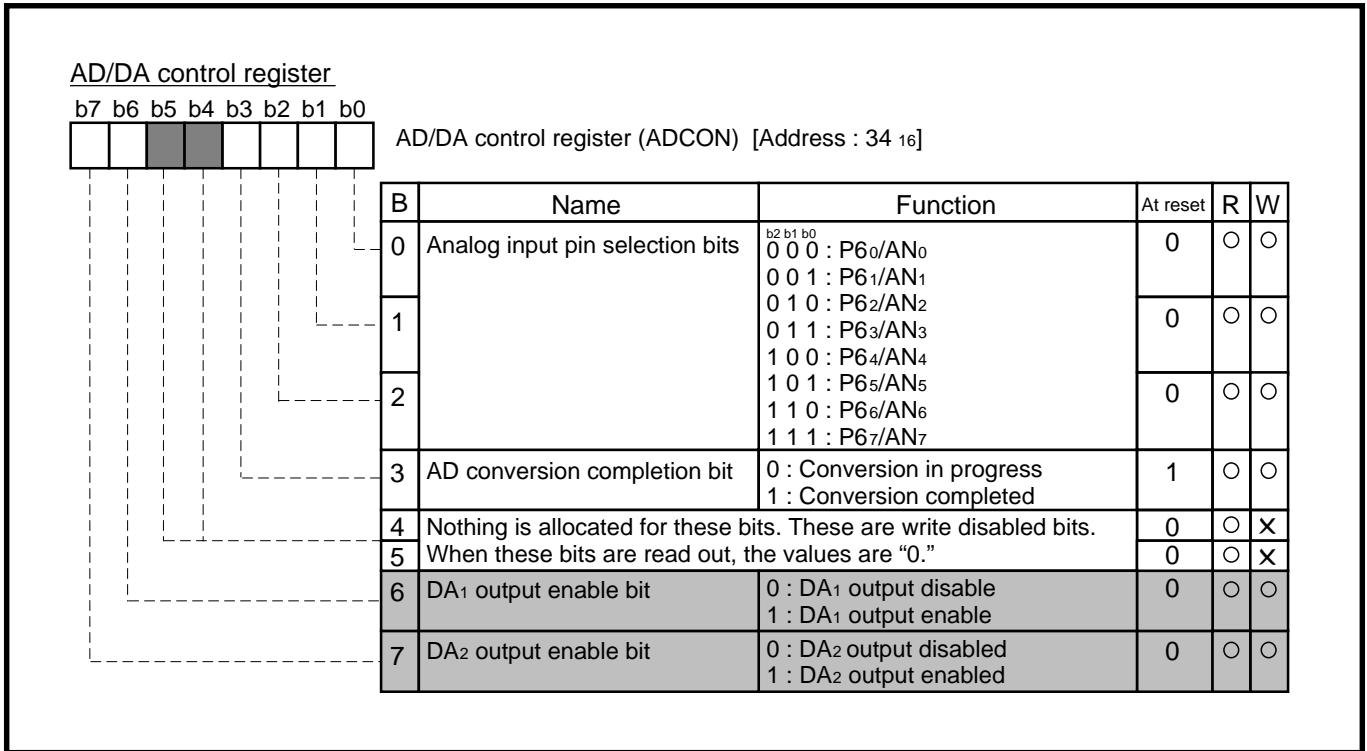

Fig. 2.4.2 Structure of AD/DA control register

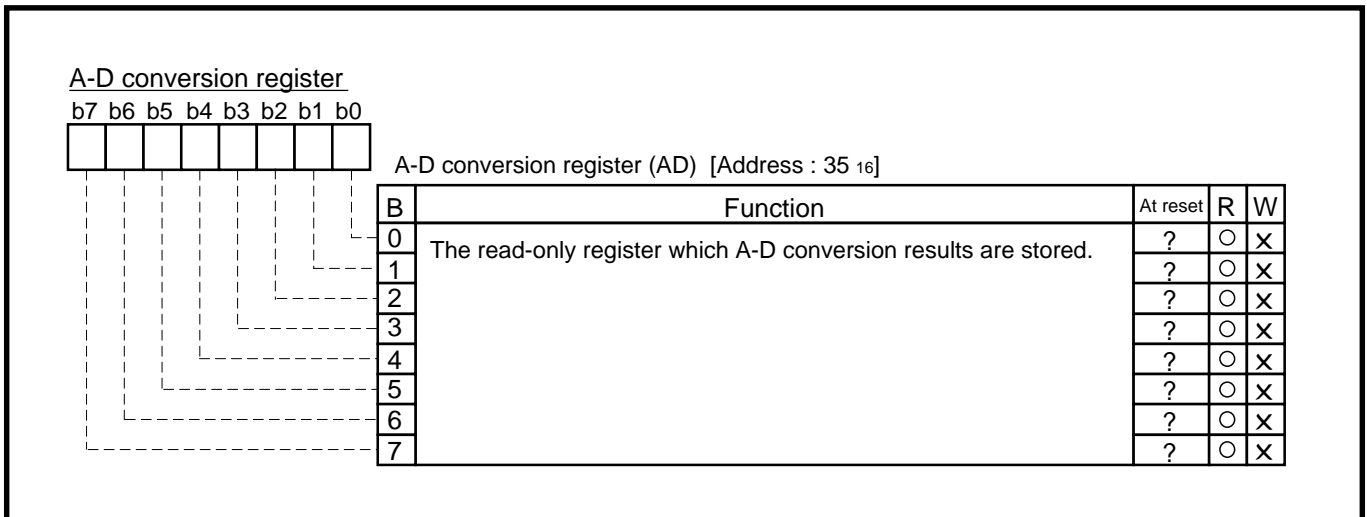

Fig. 2.4.3 Structure of A-D conversion register

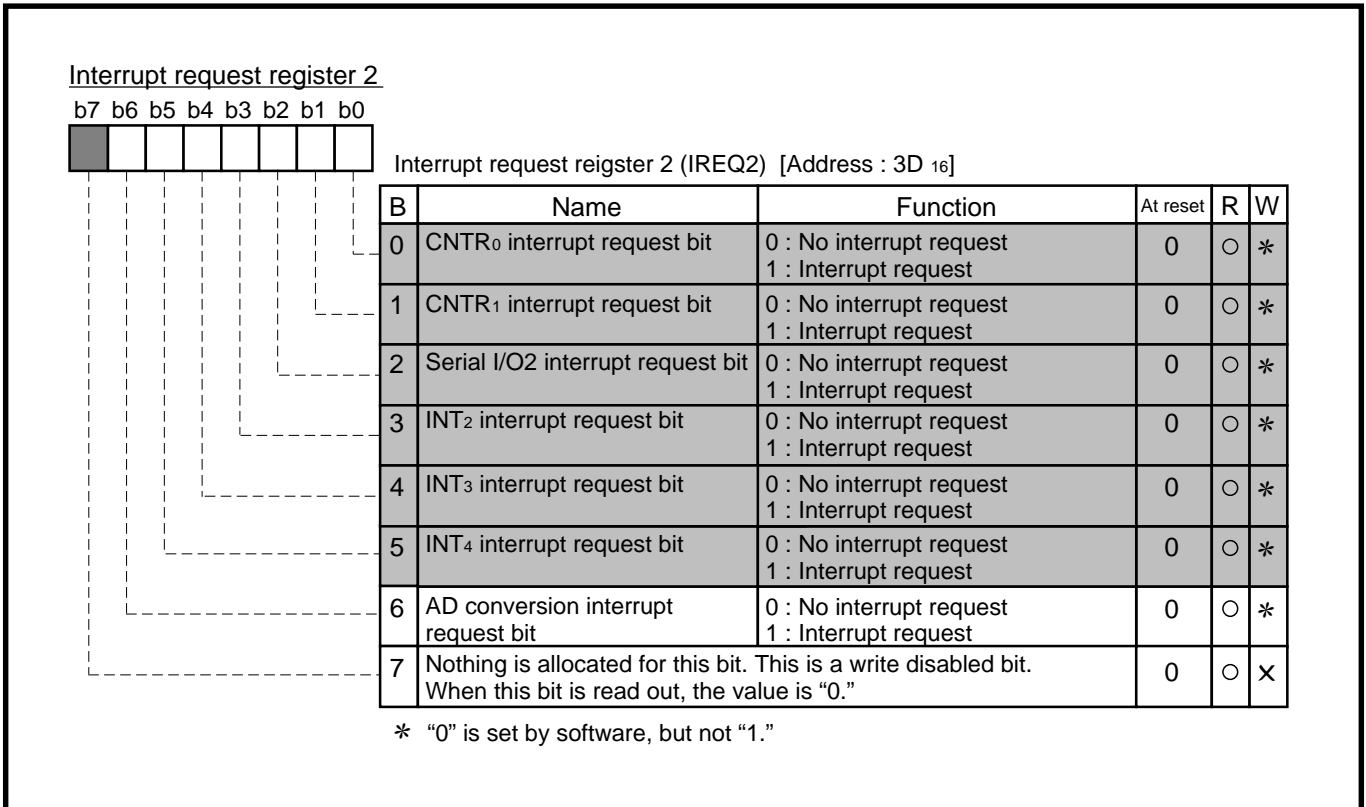

Fig. 2.4.4 Structure of Interrupt request register 2

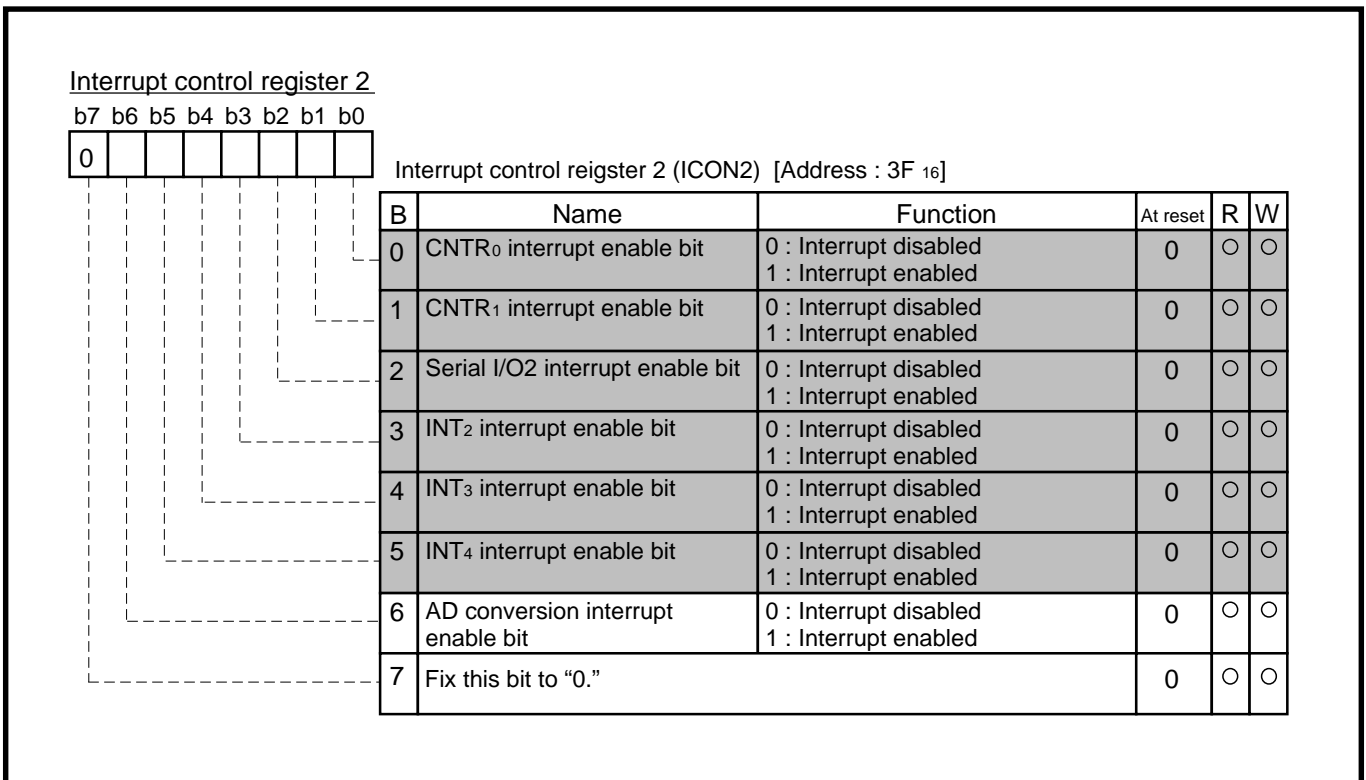

Fig. 2.4.5 Structure of Interrupt control register 2

# APPLICATION

## 2.4 A-D converter

### 2.4.3 A-D conversion application example

#### Conversion of Analog input voltage

**Outline :** The analog input voltage input from the sensor is converted into digital values.

Figure 2.4.6 shows a connection diagram, and Figure 2.4.7 shows a setting of related registers.

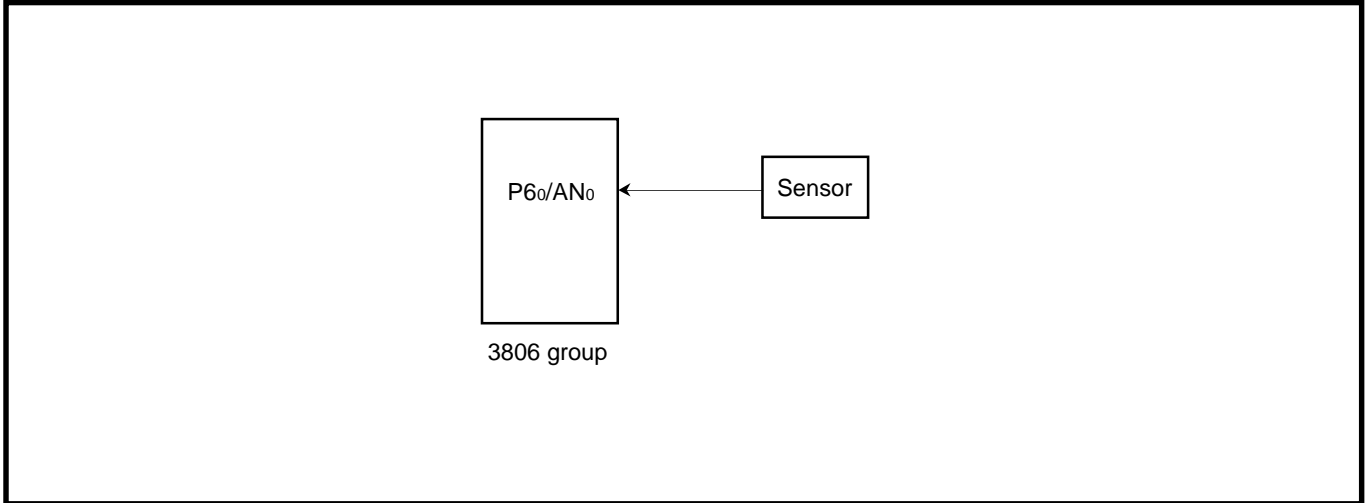

**Fig. 2.4.6 Connection diagram [Conversion of Analog input voltage]**

- Specifications :**
- The analog input voltage input from the sensor is converted into digital values.
  - The P60/AN0 pin is used as an analog input pin.

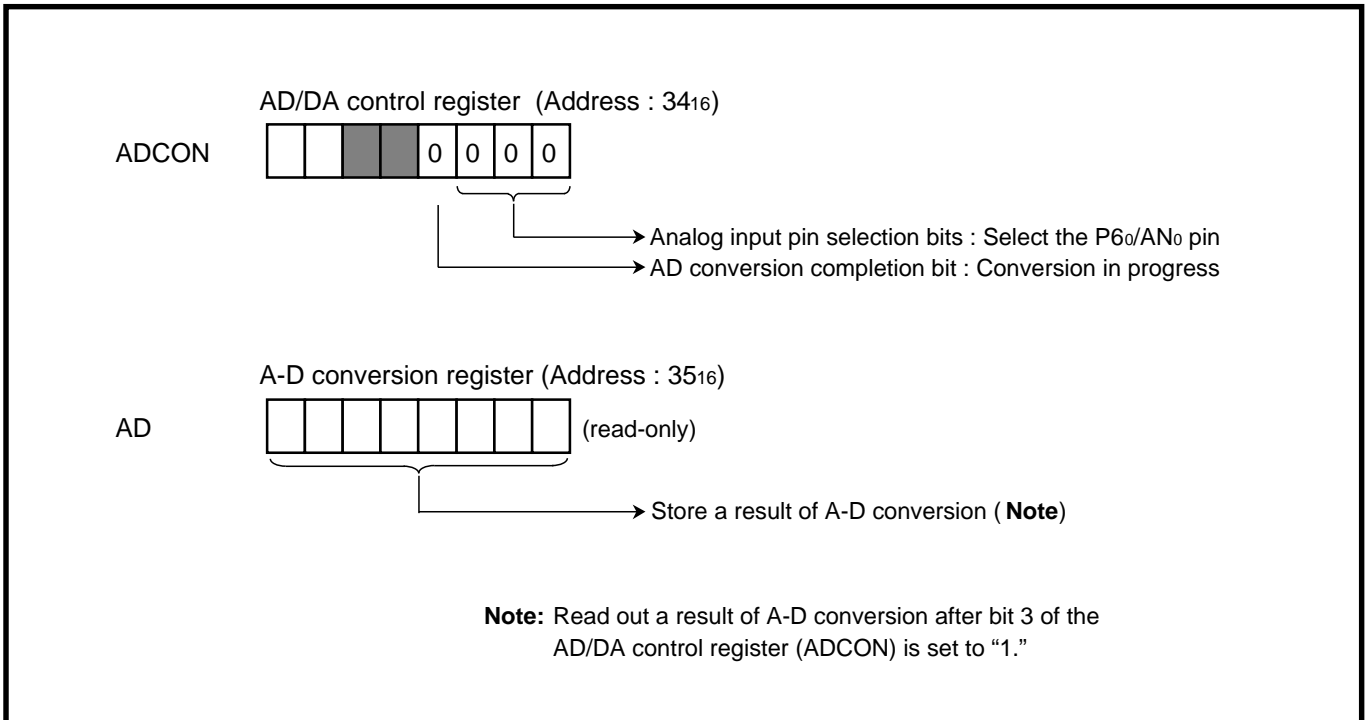

**Fig. 2.4.7 Setting of related registers [Conversion of Analog input voltage]**

**Control procedure :** By setting the related registers as shown in Figure 2.4.7, the analog input voltage input from the sensor are converted into digital values.

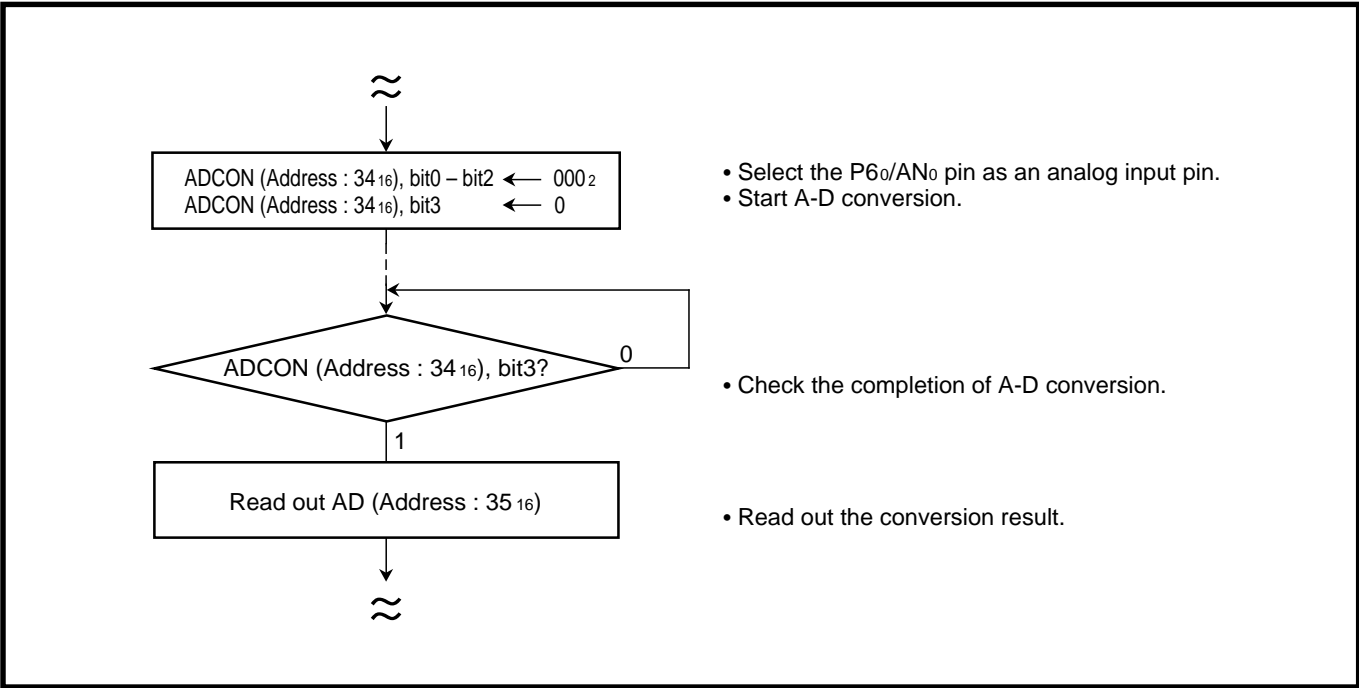

Fig. 2.4.8 Control procedure [Conversion of Analog input voltage]

# APPLICATION

## 2.5 Processor mode

### 2.5 Processor mode

#### 2.5.1 Memory map of processor mode

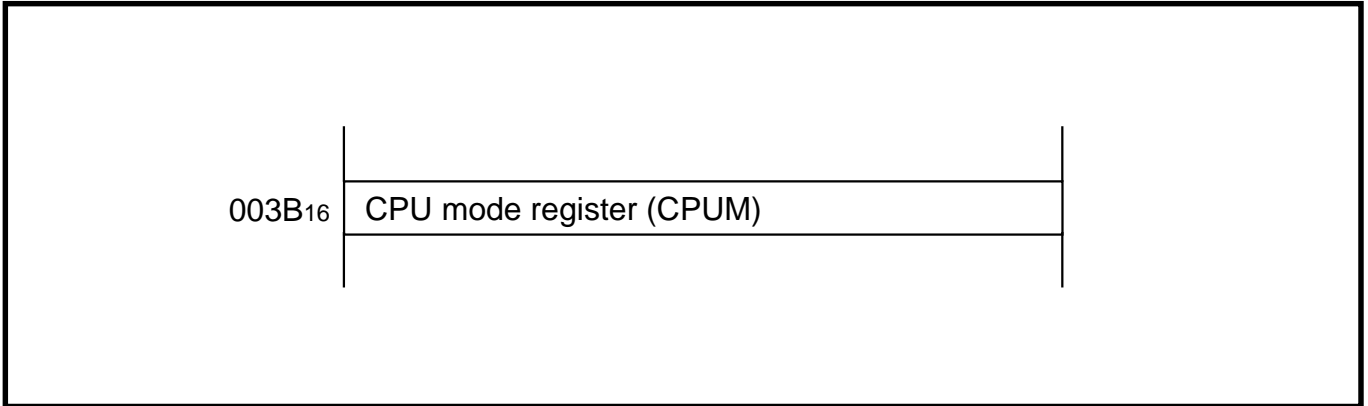

Fig. 2.5.1 Memory map of processor mode related register

#### 2.5.2 Related register

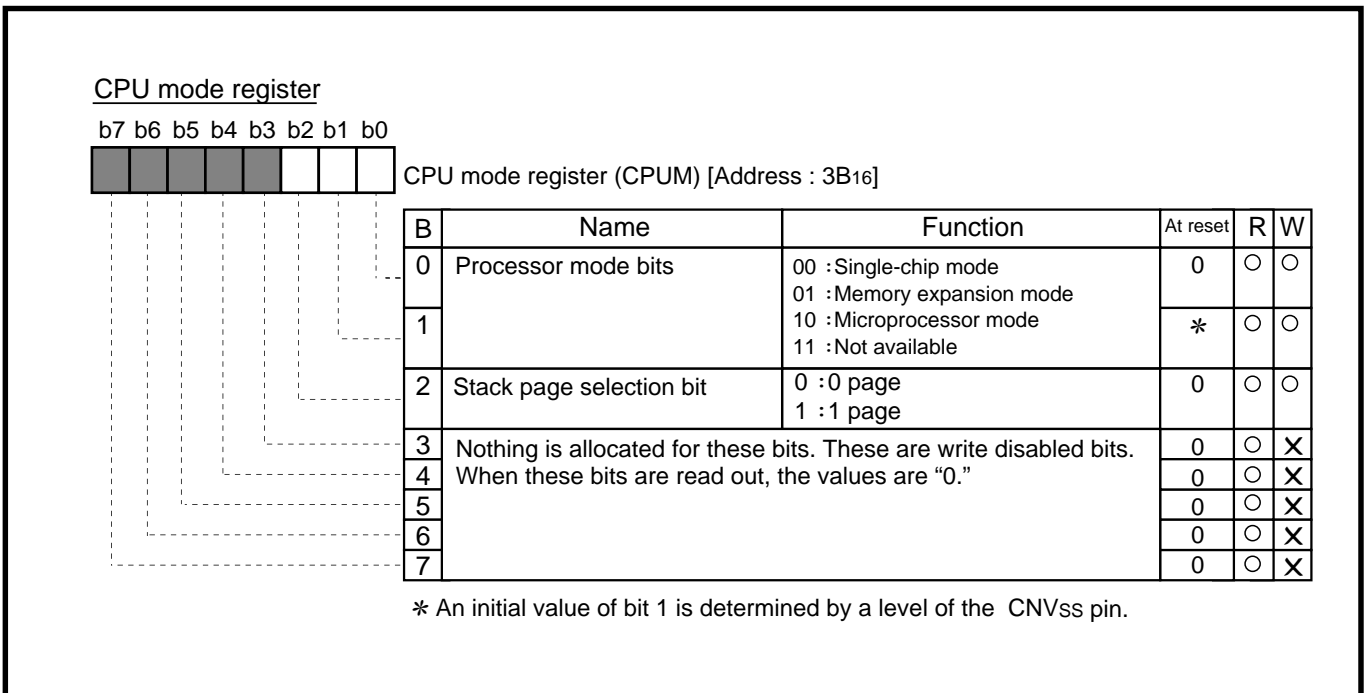

Fig. 2.5.2 Structure of CPU mode register

### 2.5.3 Processor mode application examples

#### (1) Application example of memory expansion in the case where the $\overline{ONW}$ (One-Wait) function is not used

**Outline :** The external memory is accessed in the microprocessor mode.  
 At  $f(XIN) = 8\text{ MHz}$ , an available RAM is given by the following :

- $\overline{OE}$  access time :  $t_a (\overline{OE}) \leq 50\text{ ns}$
- Setup time for writing data :  $t_{su} (D) \leq 65\text{ ns}$

For example, the M5M5256BP-10 whose address access is 100 ns is available.

Figure 2.5.3 shows an expansion example of a 32K byte ROM and a 32K byte RAM.

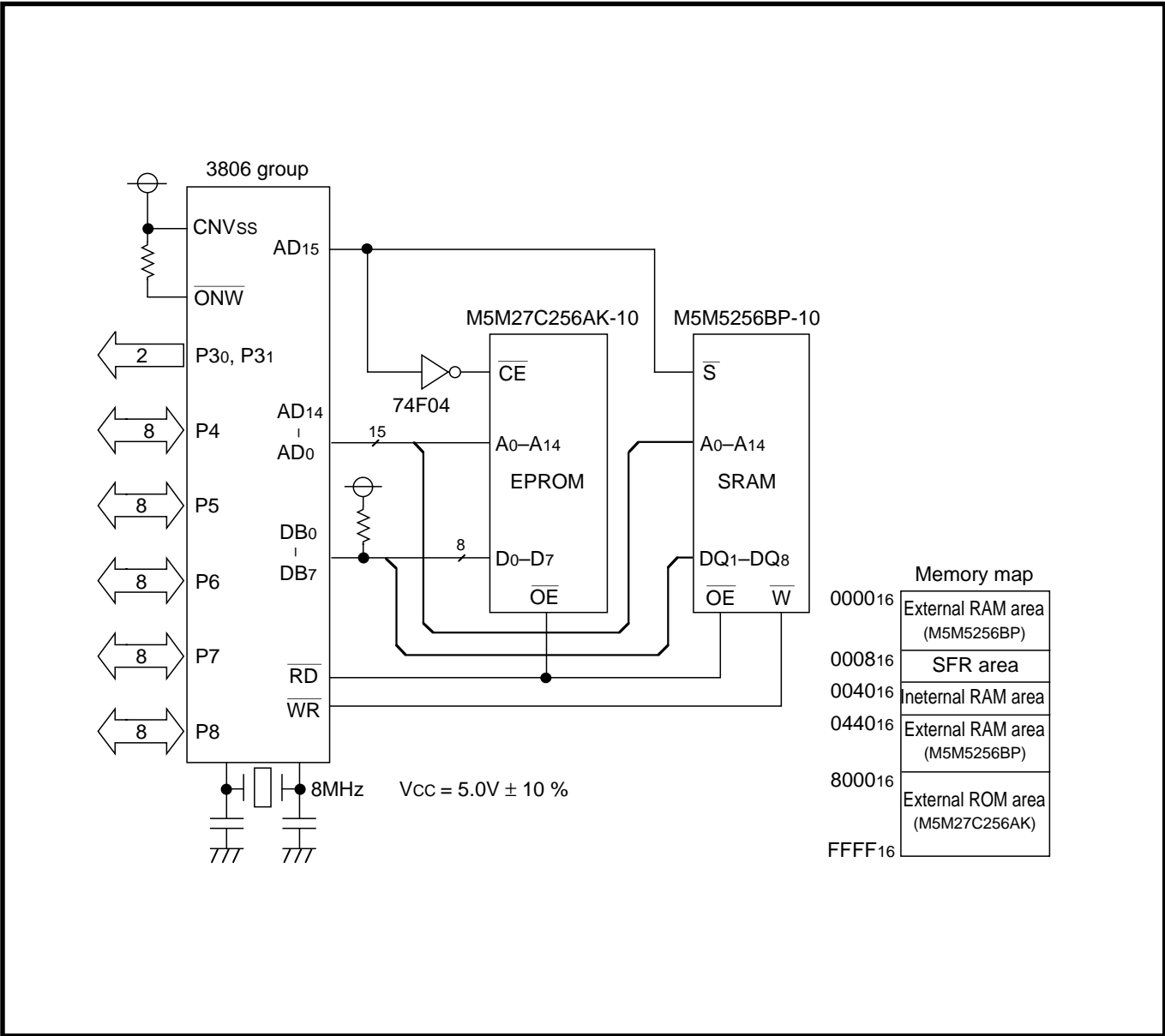

Fig. 2.5.3 Expansion example of ROM and RAM

# APPLICATION

## 2.5 Processor mode

Figure 2.5.4, Figure 2.5.5 and Figure 2.5.6 shows a standard timing at 8 MHz (No-Wait).

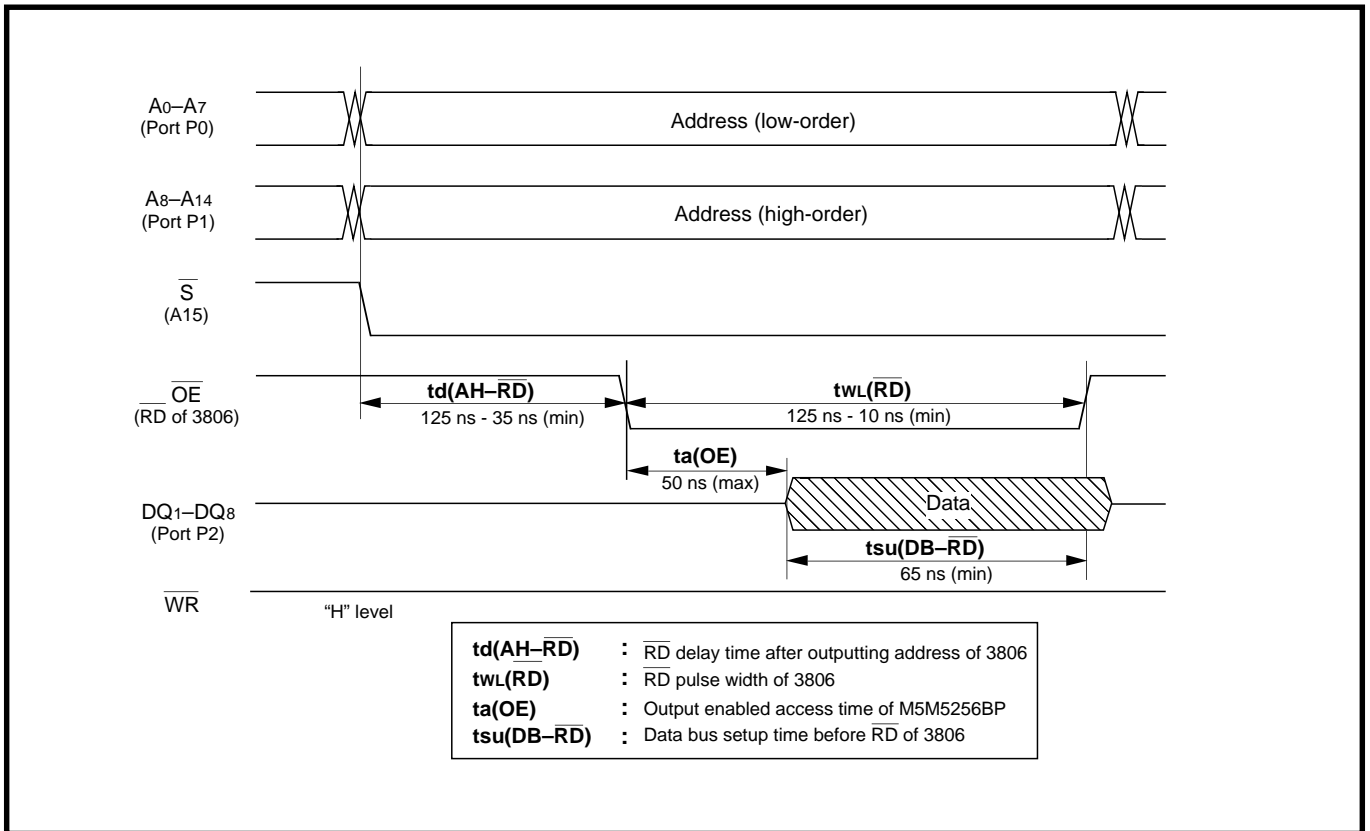

Fig. 2.5.4 Read-cycle (OE access, SRAM)

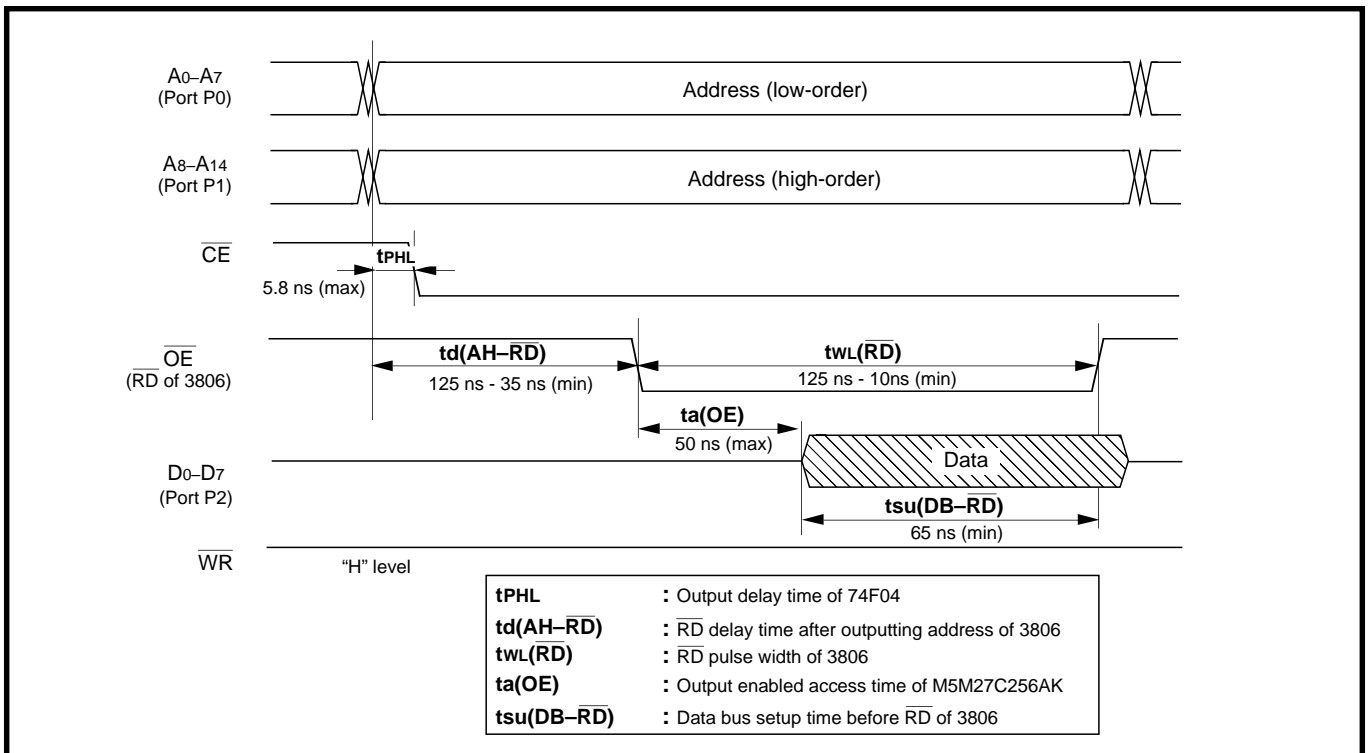

Fig. 2.5.5 Read-cycle (OE access, EPROM)

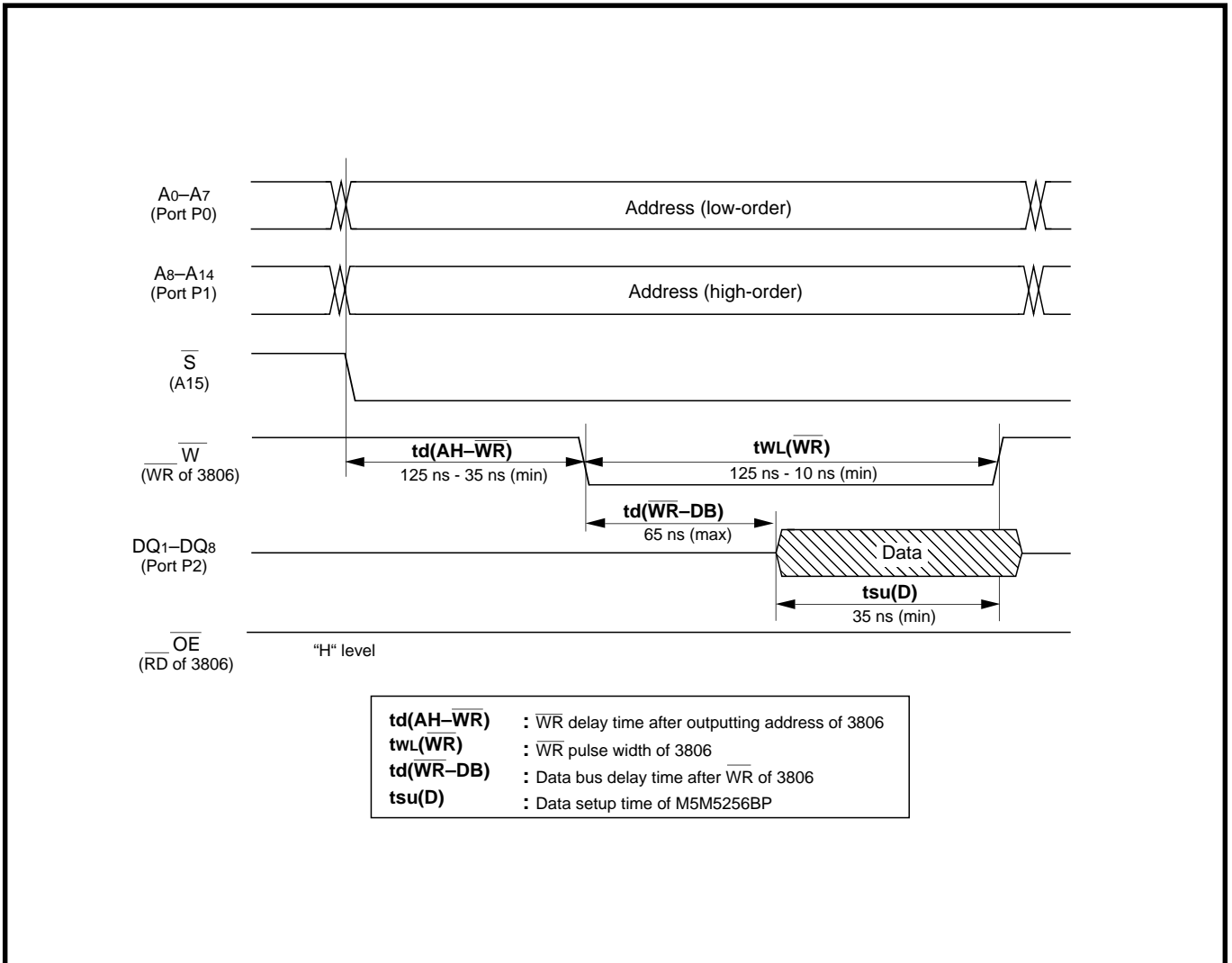

Fig. 2.5.6 Write-cycle (W control, SRAM)



# APPLICATION

## 2.5 Processor mode

### (2) Application example of memory expansion in the case where the $\overline{ONW}$ (One-Wait) function is used

**Outline :**  $\overline{ONW}$  function is used when the external memory access is slow.

If "L" level signal is input to the P32/ $\overline{ONW}$  pin while the CPU is in the read or write status, the read or write cycle corresponding to 1 cycle of  $\phi$  is extended. In the extended period, the  $\overline{RD}$  or  $\overline{WR}$  signal is kept at the "L" level. The  $\overline{ONW}$  function operates only when data is read from or written into addresses 0000<sub>16</sub> to 0007<sub>16</sub> and addresses 0440<sub>16</sub> to FFFF<sub>16</sub>.

Figure 2.5.7 shows an application example of the  $\overline{ONW}$  function.

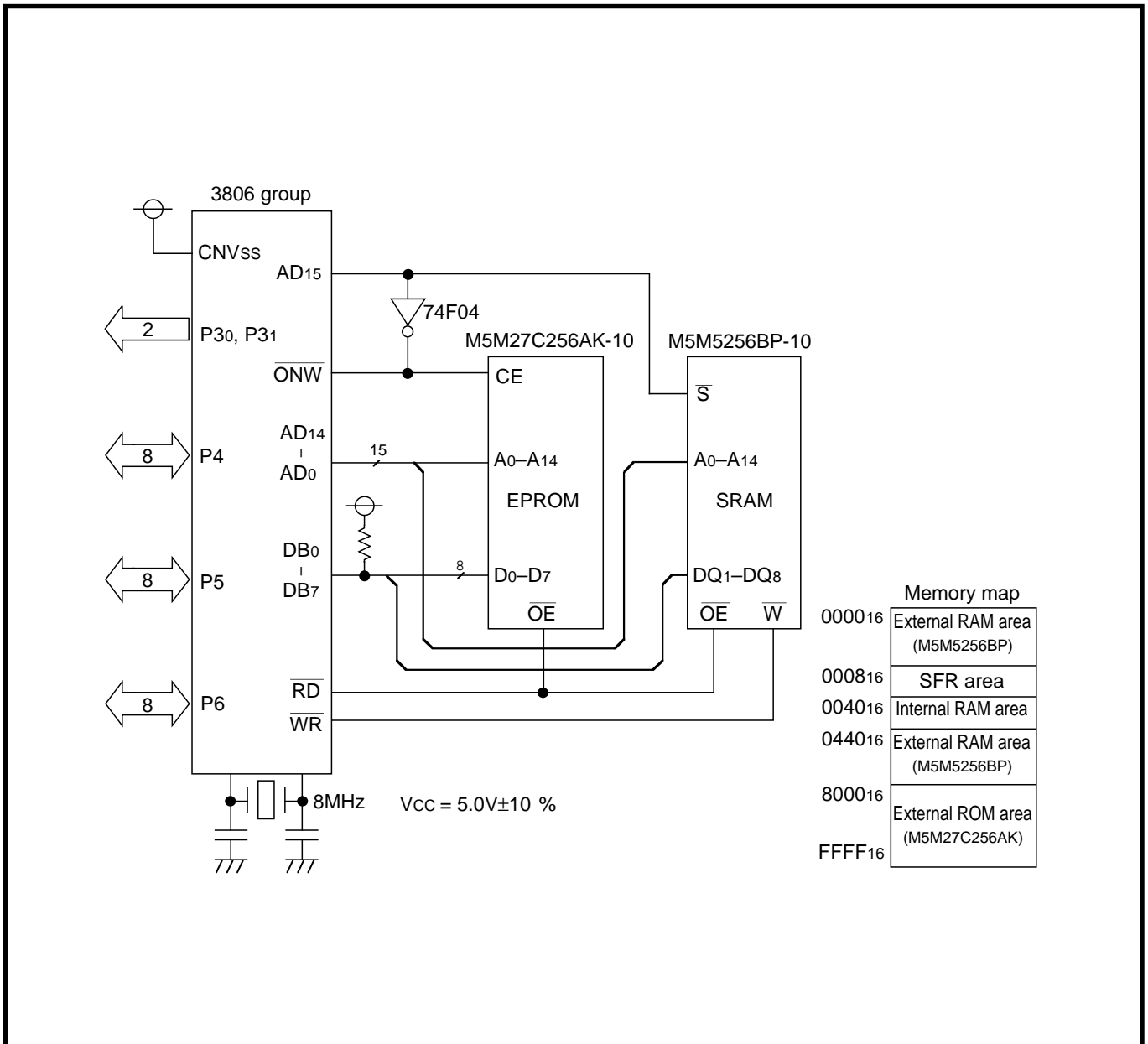

Fig. 2.5.7 Application example of the  $\overline{ONW}$  function

### (3) Application example of memory expansion in the case where the High-speed version (A-version) is used

**Outline :** High-speed version is used when the external memory access is fast.

At  $f(XIN) = 9\text{ MHz}$ , an available RAM is given by the following :

- $\overline{OE}$  access time :  $t_a (OE) \leq 35\text{ ns}$
- Setup time for writing data :  $t_{su} (D) \leq 50\text{ ns}$

For example, the M5M5256BP-70 whose address access is 70 ns is available.

Figure 2.5.8 shows an expansion example of a 32K byte ROM and a 32K byte RAM.

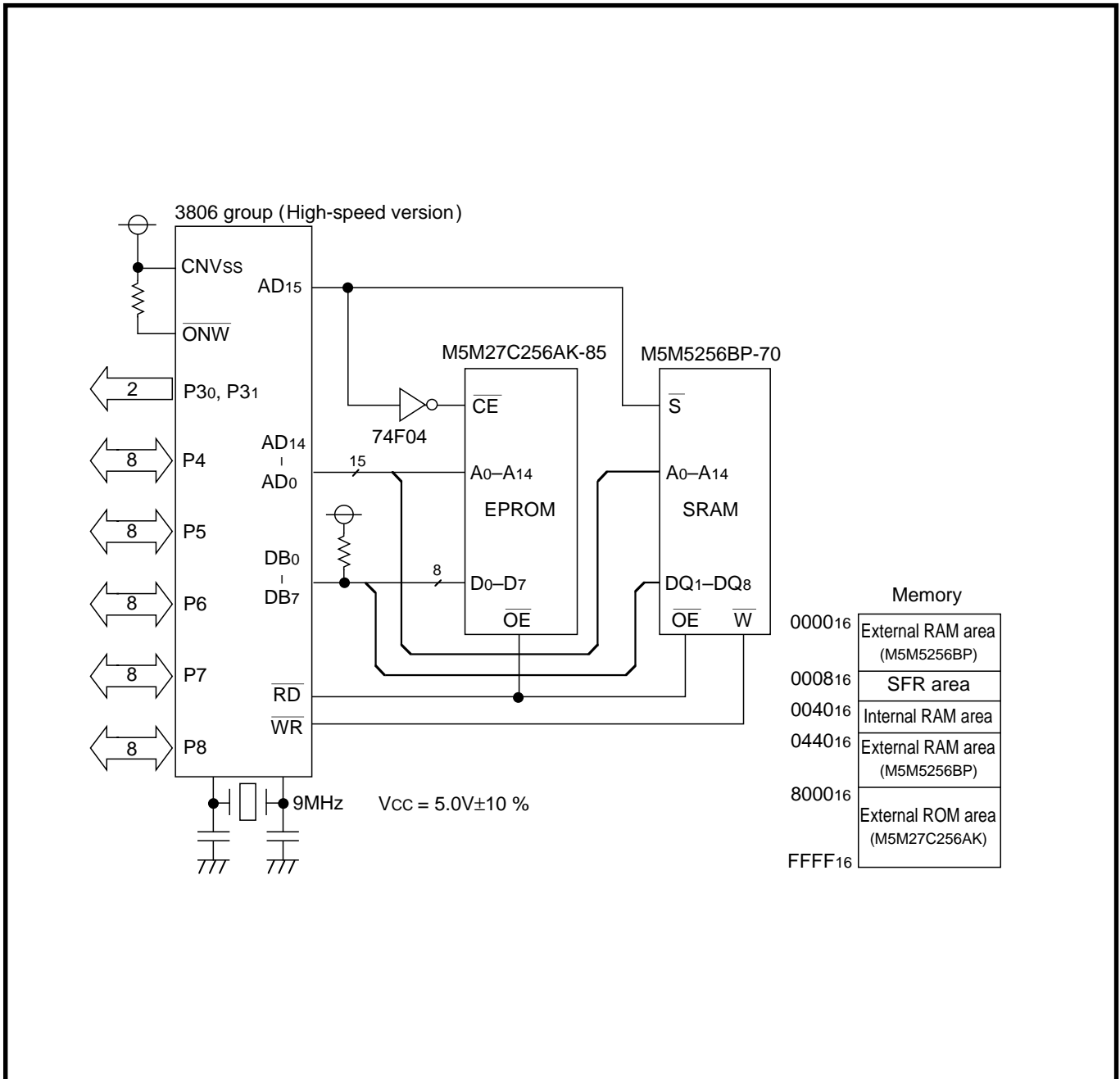

Fig. 2.5.8 Expansion example of ROM and RAM [High-speed version]

# APPLICATION

## 2.5 Processor mode

Figure 2.5.9, Figure 2.5.10 and Figure 2.5.11 shows a standard timing at 9 MHz (No-Wait).

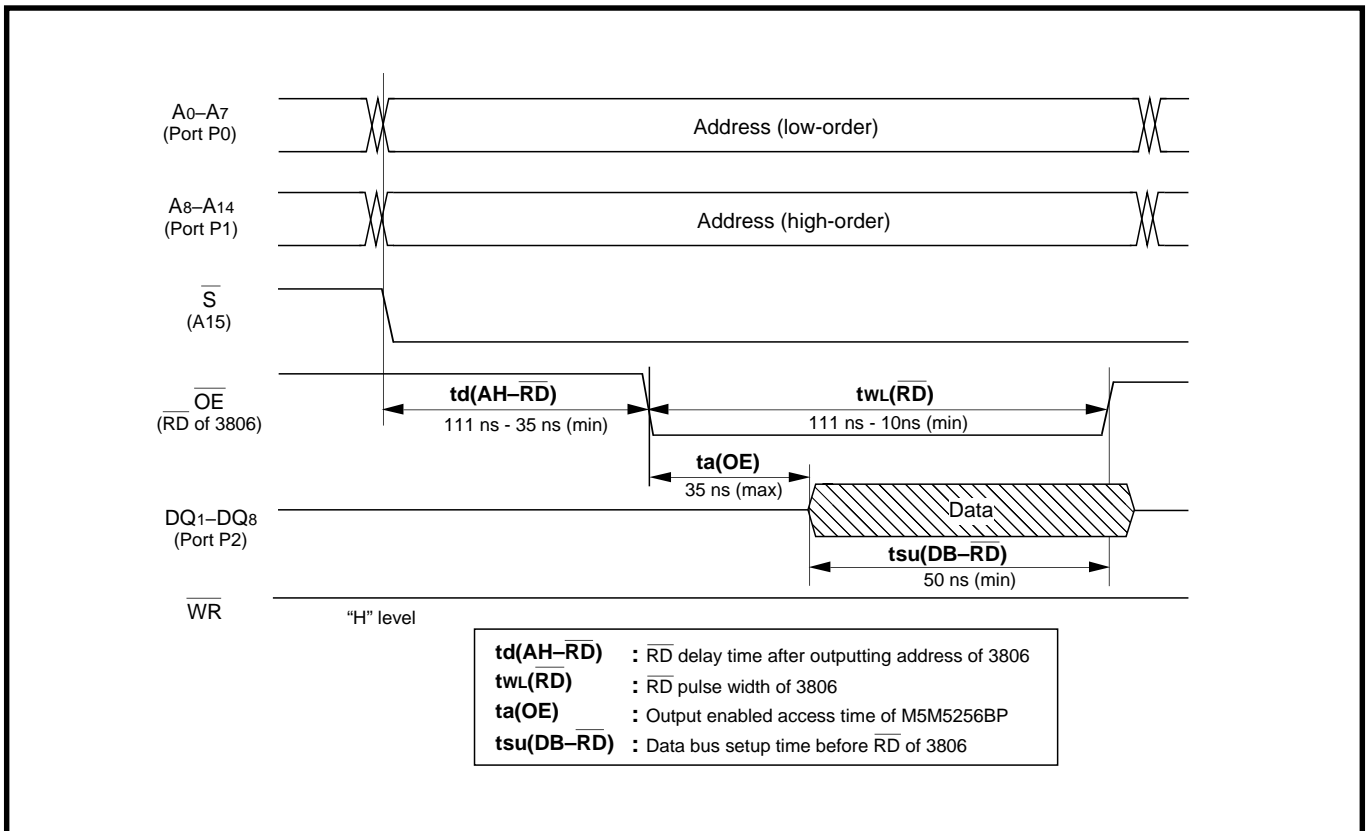

Fig. 2.5.9 Read-cycle (OE access, SRAM) [High-speed version]

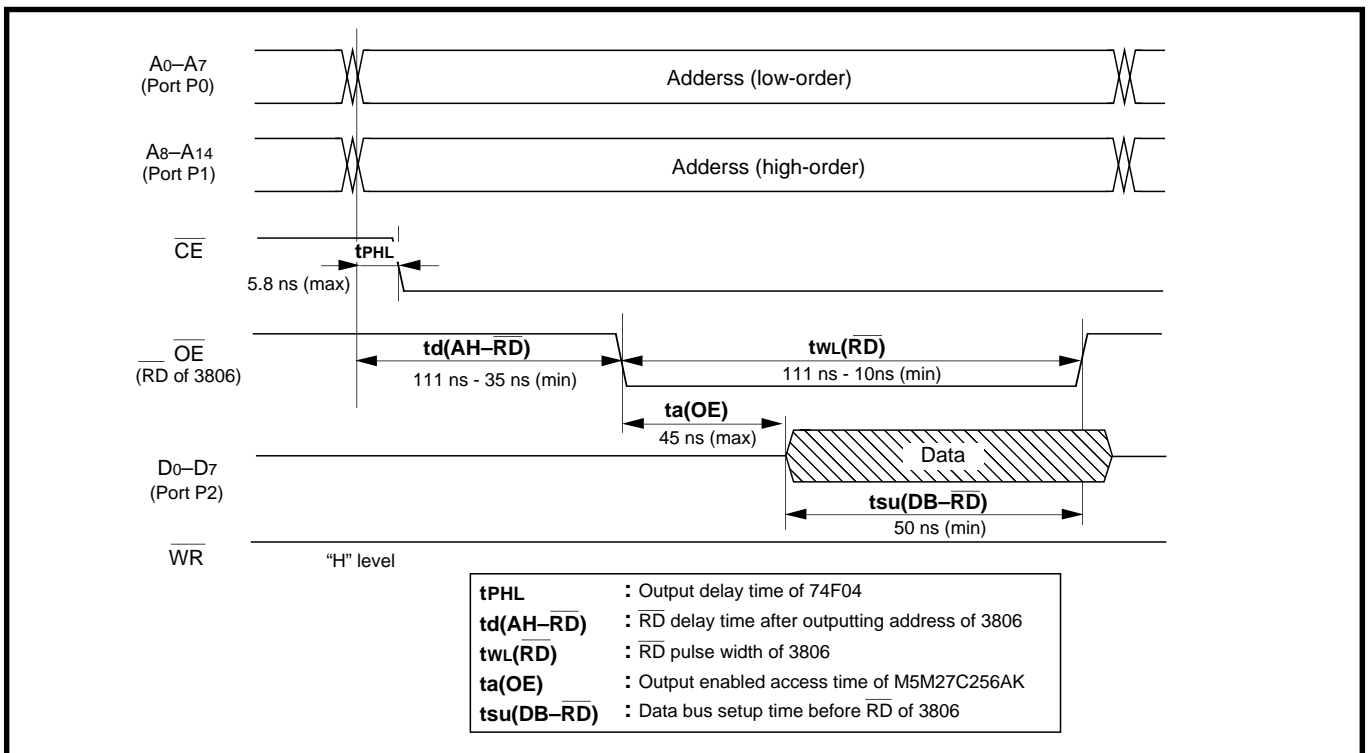

Fig. 2.5.10 Read-cycle (OE access, EPROM) [High-speed version]

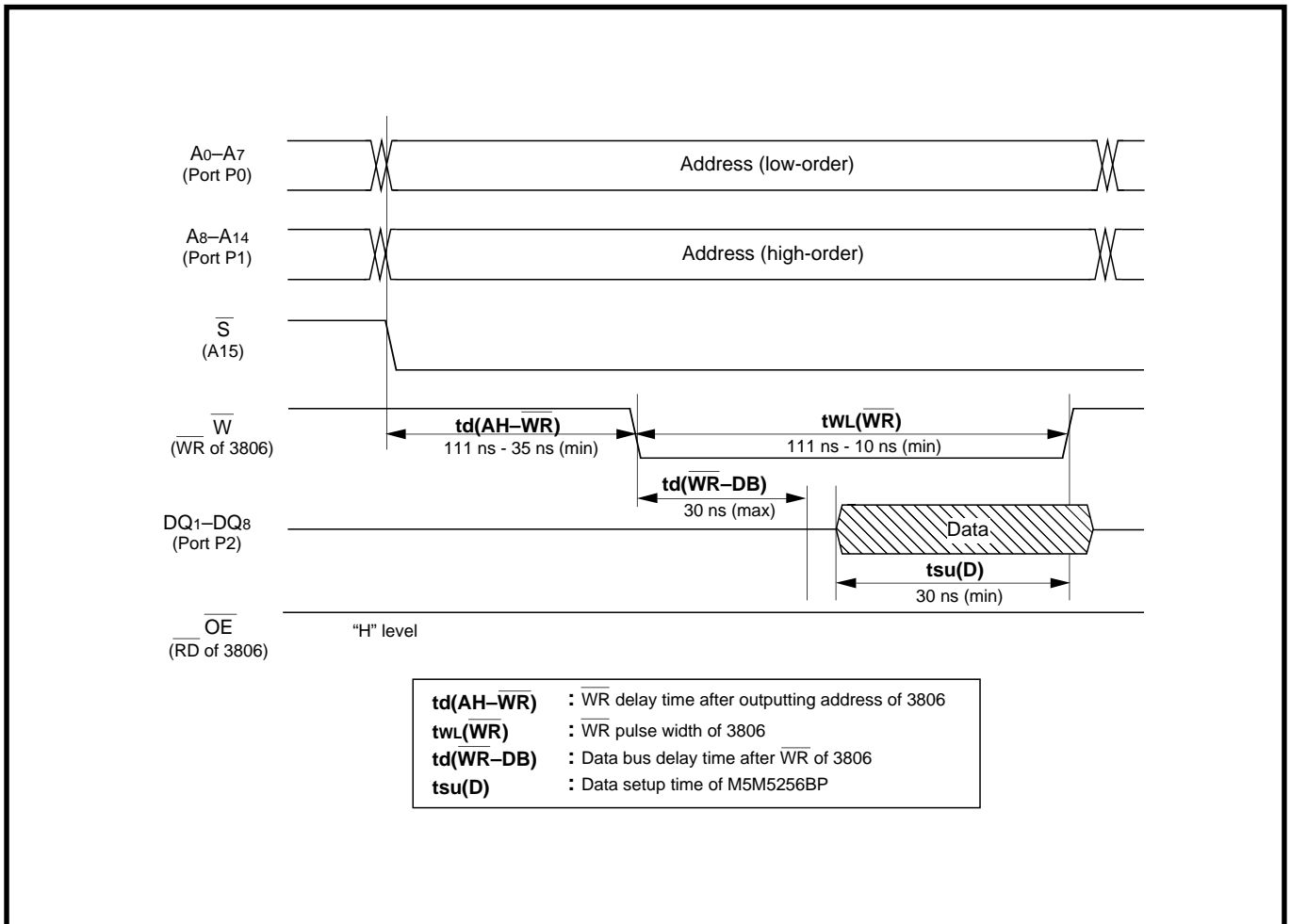

Fig. 2.5.11 Write-cycle (W control, SRAM) [High-speed version]

# APPLICATION

## 2.6 Reset

### 2.6 Reset

#### 2.6.1 Connection example of reset IC

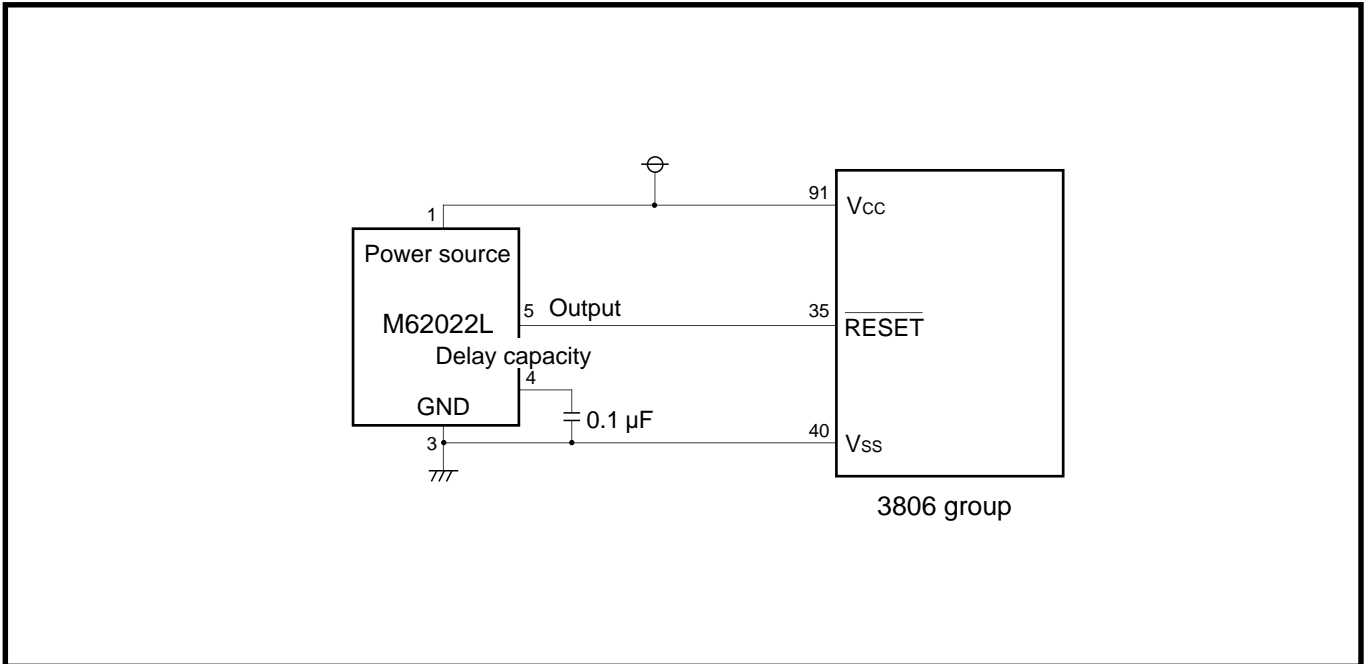

Fig. 2.6.1 Example of Poweron reset circuit

Figure 2.6.2 shows the system example which switch to the RAM backup mode by detecting a drop of the system power source voltage with the INT interrupt.

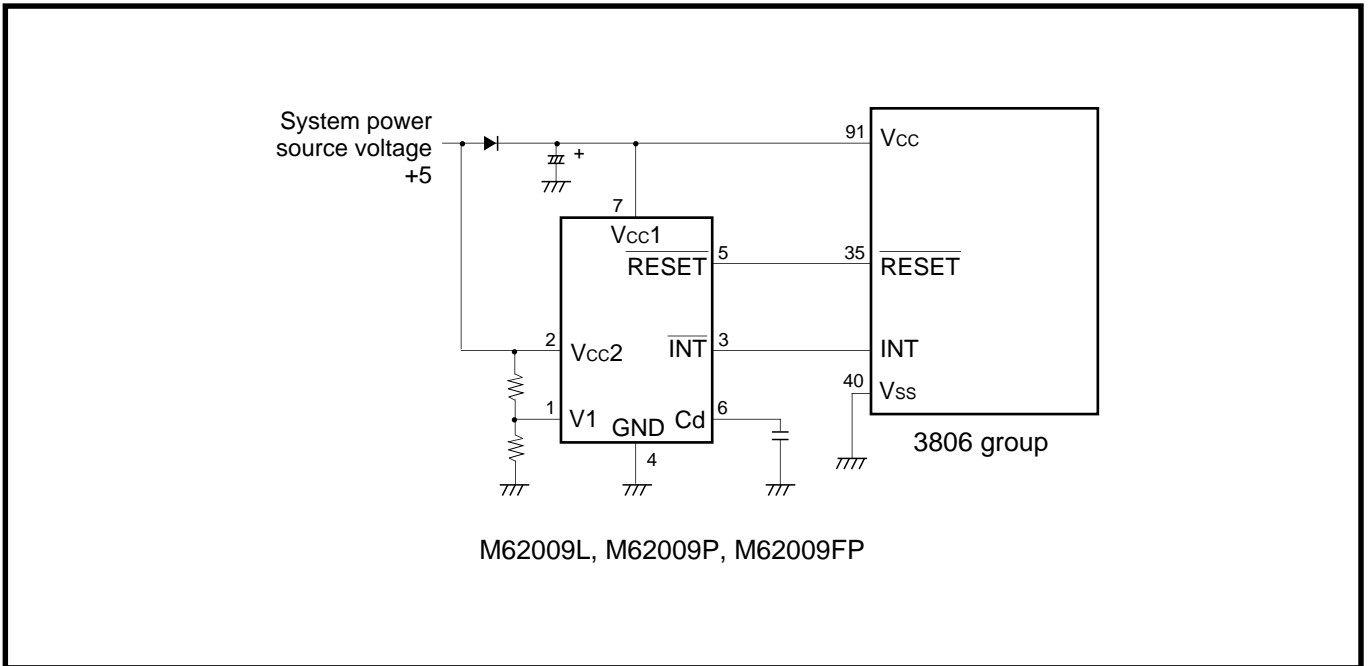

Fig. 2.6.2 RAM back-up system



# CHAPTER 3

## **APPENDIX**

- 3.1 Electrical characteristics
- 3.2 Standard characteristics
- 3.3 Notes on use
- 3.4 Countermeasures against noise
- 3.5 List of registers
- 3.6 Mask ROM ordering method
- 3.7 Mark specification form
- 3.8 Package outline
- 3.9 List of instruction codes
- 3.10 Machine instructions
- 3.11 SFR memory map
- 3.12 Pin configuration

# APPENDIX

## 3.1 Electrical characteristics

### 3.1 ELECTRICAL CHARACTERISTICS

#### 3.1.1 Absolute maximum ratings

Table 3.1.1 Absolute maximum ratings

Symbol	Parameter	Conditions	Ratings	Unit
V <sub>CC</sub>	Power source voltage	All voltages are based on V <sub>SS</sub> . Output transistors are cut off.	-0.3 to 7.0	V
V <sub>I</sub>	Input voltage P00–P07, P10–P17, P20–P27, P30–P37, P40–P47, P50–P57, P60–P67, P70–P77, P80–P87, V <sub>REF</sub>		-0.3 to V <sub>CC</sub> +0.3	V
V <sub>I</sub>	Input voltage RESET, X <sub>IN</sub>		-0.3 to V <sub>CC</sub> +0.3	V
V <sub>I</sub>	Input voltage CNV <sub>SS</sub>		-0.3 to 13	V
V <sub>O</sub>	Output voltage P00–P07, P10–P17, P20–P27, P30–P37, P40–P47, P50–P57, P60–P67, P70–P77, P80–P87, X <sub>OUT</sub>		-0.3 to V <sub>CC</sub> +0.3	V
P <sub>d</sub>	Power dissipation	T <sub>a</sub> = 25 °C	500	mW
T <sub>opr</sub>	Operating temperature		-20 to 85	°C
T <sub>stg</sub>	Storage temperature		-40 to 125	°C

## 3.1 Electrical characteristics

### 3.1.2 Recommended operating conditions

**Table 3.1.2 Recommended operating conditions** ( $V_{CC} = 3.0$  to  $5.5$  V,  $T_a = -20$  to  $85$  °C, unless otherwise noted)

Symbol	Parameter		Limits			Unit
			Min.	Typ.	Max.	
V <sub>CC</sub>	Power source voltage ( $f(X_{IN}) \leq 2$ MHz) (Note 1)		3.0	5.0	5.5	V
	Power source voltage ( $f(X_{IN}) = 8$ MHz) (Note 1)		4.0	5.0	5.5	
V <sub>SS</sub>	Power source voltage			0		V
V <sub>REF</sub>	Analog reference voltage (when A-D converter is used)		2.0		V <sub>CC</sub>	V
	Analog reference voltage (when D-A converter is used)		3.0		V <sub>CC</sub>	
AV <sub>SS</sub>	Analog power source voltage			0		V
V <sub>IA</sub>	Analog input voltage	AN <sub>0</sub> –AN <sub>7</sub>	AV <sub>SS</sub>		V <sub>CC</sub>	V
V <sub>IH</sub>	"H" input voltage	P <sub>00</sub> –P <sub>07</sub> , P <sub>10</sub> –P <sub>17</sub> , P <sub>20</sub> –P <sub>27</sub> , P <sub>30</sub> –P <sub>37</sub> , P <sub>40</sub> –P <sub>47</sub> , P <sub>50</sub> –P <sub>57</sub> , P <sub>60</sub> –P <sub>67</sub> , P <sub>70</sub> –P <sub>77</sub> , P <sub>80</sub> –P <sub>87</sub>	0.8 V <sub>CC</sub>		V <sub>CC</sub>	V
V <sub>IH</sub>	"H" input voltage	RESET, X <sub>IN</sub> , CNV <sub>SS</sub>	0.8 V <sub>CC</sub>		V <sub>CC</sub>	V
V <sub>IL</sub>	"L" input voltage	P <sub>00</sub> –P <sub>07</sub> , P <sub>10</sub> –P <sub>17</sub> , P <sub>20</sub> –P <sub>27</sub> , P <sub>30</sub> –P <sub>37</sub> , P <sub>40</sub> –P <sub>47</sub> , P <sub>50</sub> –P <sub>57</sub> , P <sub>60</sub> –P <sub>67</sub> , P <sub>70</sub> –P <sub>77</sub> , P <sub>80</sub> –P <sub>87</sub>	0		0.2 V <sub>CC</sub>	V
V <sub>IL</sub>	"L" input voltage	RESET	0		0.2 V <sub>CC</sub>	V
V <sub>IL</sub>	"L" input voltage	X <sub>IN</sub>	0		0.16 V <sub>CC</sub>	V
V <sub>IL</sub>	"L" input voltage	CNV <sub>SS</sub>	0		0.2 V <sub>CC</sub>	V
ΣI <sub>OH(peak)</sub>	"H" total peak output current	P <sub>00</sub> –P <sub>07</sub> , P <sub>10</sub> –P <sub>17</sub> , P <sub>20</sub> –P <sub>27</sub> , P <sub>30</sub> –P <sub>37</sub> , P <sub>80</sub> –P <sub>87</sub> (Note 2)			–80	mA
ΣI <sub>OH(peak)</sub>	"H" total peak output current	P <sub>40</sub> –P <sub>47</sub> , P <sub>50</sub> –P <sub>57</sub> , P <sub>60</sub> –P <sub>67</sub> (Note 2)			–80	mA
ΣI <sub>OL(peak)</sub>	"L" total peak output current	P <sub>00</sub> –P <sub>07</sub> , P <sub>10</sub> –P <sub>17</sub> , P <sub>20</sub> –P <sub>27</sub> , P <sub>30</sub> –P <sub>37</sub> , P <sub>80</sub> –P <sub>87</sub> (Note 2)			80	mA
ΣI <sub>OL(peak)</sub>	"L" total peak output current	P <sub>40</sub> –P <sub>47</sub> , P <sub>50</sub> –P <sub>57</sub> , P <sub>60</sub> –P <sub>67</sub> , P <sub>70</sub> –P <sub>77</sub> (Note 2)			80	mA
ΣI <sub>OH(avg)</sub>	"H" total average output current	P <sub>00</sub> –P <sub>07</sub> , P <sub>10</sub> –P <sub>17</sub> , P <sub>20</sub> –P <sub>27</sub> , P <sub>30</sub> –P <sub>37</sub> , P <sub>80</sub> –P <sub>87</sub> (Note 2)			–40	mA
ΣI <sub>OH(avg)</sub>	"H" total average output current	P <sub>40</sub> –P <sub>47</sub> , P <sub>50</sub> –P <sub>57</sub> , P <sub>60</sub> –P <sub>67</sub> (Note 2)			–40	mA
ΣI <sub>OL(avg)</sub>	"L" total average output current	P <sub>00</sub> –P <sub>07</sub> , P <sub>10</sub> –P <sub>17</sub> , P <sub>20</sub> –P <sub>27</sub> , P <sub>30</sub> –P <sub>37</sub> , P <sub>80</sub> –P <sub>87</sub> (Note 2)			40	mA
ΣI <sub>OL(avg)</sub>	"L" total average output current	P <sub>40</sub> –P <sub>47</sub> , P <sub>50</sub> –P <sub>57</sub> , P <sub>60</sub> –P <sub>67</sub> , P <sub>70</sub> –P <sub>77</sub> (Note 2)			40	mA
I <sub>OH(peak)</sub>	"H" peak output current	P <sub>00</sub> –P <sub>07</sub> , P <sub>10</sub> –P <sub>17</sub> , P <sub>20</sub> –P <sub>27</sub> , P <sub>30</sub> –P <sub>37</sub> , P <sub>40</sub> –P <sub>47</sub> , P <sub>50</sub> –P <sub>57</sub> , P <sub>60</sub> –P <sub>67</sub> , P <sub>80</sub> –P <sub>87</sub> (Note 3)			–10	mA
I <sub>OL(peak)</sub>	"L" peak output current	P <sub>00</sub> –P <sub>07</sub> , P <sub>10</sub> –P <sub>17</sub> , P <sub>20</sub> –P <sub>27</sub> , P <sub>30</sub> –P <sub>37</sub> , P <sub>40</sub> –P <sub>47</sub> , P <sub>50</sub> –P <sub>57</sub> , P <sub>60</sub> –P <sub>67</sub> , P <sub>70</sub> –P <sub>77</sub> , P <sub>80</sub> –P <sub>87</sub> (Note 3)			10	mA
I <sub>OH(avg)</sub>	"H" average output current	P <sub>00</sub> –P <sub>07</sub> , P <sub>10</sub> –P <sub>17</sub> , P <sub>20</sub> –P <sub>27</sub> , P <sub>30</sub> –P <sub>37</sub> , P <sub>40</sub> –P <sub>47</sub> , P <sub>50</sub> –P <sub>57</sub> , P <sub>60</sub> –P <sub>67</sub> , P <sub>80</sub> –P <sub>87</sub> (Note 4)			–5	mA
I <sub>OL(avg)</sub>	"L" average output current	P <sub>00</sub> –P <sub>07</sub> , P <sub>10</sub> –P <sub>17</sub> , P <sub>20</sub> –P <sub>27</sub> , P <sub>30</sub> –P <sub>37</sub> , P <sub>40</sub> –P <sub>47</sub> , P <sub>50</sub> –P <sub>57</sub> , P <sub>60</sub> –P <sub>67</sub> , P <sub>70</sub> –P <sub>77</sub> , P <sub>80</sub> –P <sub>87</sub> (Note 4)			5	mA
f(X <sub>IN</sub> )	Internal clock oscillation frequency ( $V_{CC} = 4.0$ to $5.5$ V)				8	MHz
	Internal clock oscillation frequency ( $V_{CC} = 3.0$ to $4.0$ V)				6 V <sub>CC</sub> –16	

**Note 1:** The minimum power source voltage is  $\frac{X+16}{6}$  [V] ( $f(X_{IN}) = X$  MHz) on the condition of  $2 \text{ MHz} < f(X_{IN}) < 8 \text{ MHz}$ .

**2:** The total output current is the sum of all the currents flowing through all the applicable ports. The total average current is an average value measured over 100 ms. The total peak current is the peak value of all the currents.

**3:** The peak output current is the peak current flowing in each port.

**4:** The average output current I<sub>OL(avg)</sub>, I<sub>OH(avg)</sub> in an average value measured over 100 ms.



# APPENDIX

## 3.1 Electrical characteristics

### 3.1.3 Electrical characteristics

**Table 3.1.3 Electrical characteristics** ( $V_{CC} = 3.0$  to  $5.5$  V,  $V_{SS} = 0$  V,  $T_a = -20$  to  $85$  °C, unless otherwise noted)

Symbol	Parameter	Test conditions	Limits			Unit
			Min.	Typ.	Max.	
VOH	"H" output voltage P00–P07, P10–P17, P20–P27, P30–P37, P40–P47, P50–P57, P60–P67, P80–P87 (Note 1)	IOH = –10 mA VCC = 4.0 to 5.5 V	VCC–2.0			V
			VCC–1.0			
VOL	"L" output voltage P00–P07, P10–P17, P20–P27, P30–P37, P40–P47, P50–P57, P60–P67, P70–P77, P80–P87	IOL = 10 mA VCC = 4.0 to 5.5 V			2.0	V
					1.0	
VT+ – VT–	Hysteresis CNTR0, CNTR1, INT0–INT4			0.4		V
VT+ – VT–	Hysteresis RXD, SCLK1, SIN2, SCLK2			0.5		V
VT+ – VT–	Hysteresis RESET			0.5		V
IiH	"H" input current P00–P07, P10–P17, P20–P27, P30–P37, P40–P47, P50–P57, P60–P67, P70–P77, P80–P87	Vi = VCC			5.0	μA
IiH	"H" input current RESET, CNVSS	Vi = VCC			5.0	μA
IiH	"H" input current XIN	Vi = VCC		4		μA
IiL	"L" input current P00–P07, P10–P17, P20–P27, P30–P37, P40–P47, P50–P57, P60–P67, P70–P77, P80–P87	Vi = VSS			–5.0	μA
IiL	"L" input current RESET, CNVSS	Vi = VSS			–5.0	μA
IiL	"L" input current XIN	Vi = VSS		–4		μA
VRAM	RAM hold voltage	When clock stopped	2.0		5.5	V
ICC	Power source current	f(XIN) = 8 MHz, VCC = 5 V		6.4	13	mA
		f(XIN) = 5 MHz, VCC = 5 V		4	8	
		f(XIN) = 2 MHz, VCC = 3 V		0.8	2.0	
		When WIT instruction is executed with f(XIN) = 8 MHz, VCC = 5 V		1.5		
		When WIT instruction is executed with f(XIN) = 5 MHz, VCC = 5 V		1		
		When WIT instruction is executed with f(XIN) = 2 MHz, VCC = 3 V		0.2		
		When STP instruction is executed with clock stopped, output transistors isolated.	Ta = 25 °C (Note 2)		0.1	1
	Ta = 85 °C (Note 2)			10		

**Note 1:** P45 is measured when the P45/TxD P-channel output disable bit of the UART control register (bit 4 of address 001B16) is "0".

**2:** With output transistors isolated and A-D converter having completed conversion, and not including current flowing through VREF pin.

### 3.1.4 A-D converter characteristics

**Table 3.1.4 A-D converter characteristics**

( $V_{CC} = 3.0$  to  $5.5$  V,  $V_{SS} = AV_{SS} = 0$  V,  $V_{REF} = 2.0$  V to  $V_{CC}$ ,  $T_a = -20$  to  $85$  °C, unless otherwise noted)

Symbol	Parameter	Test conditions	Limits			Unit
			Min.	Typ.	Max.	
—	Resolution				8	Bits
—	Absolute accuracy (excluding quantization error)			±1	±2.5	LSB
tCONV	Conversion time				50	tC(φ)
RLADDER	Ladder resistor			35		kΩ
IVREF	Reference power source input current (Note)	VREF = 5.0 V	50	150	200	μA
Ii(AD)	A-D port input current			0.5	5.0	μA

**Note:** When D-A conversion registers (addresses 003616 and 003716) contain "0016".

## 3.1 Electrical characteristics

### 3.1.5 D-A converter characteristics

**Table 3.1.5 D-A converter characteristics**

(VCC = 3.0 to 5.5 V, VSS = AVSS = 0 V, VREF = 3.0 V to VCC, Ta = -20 to 85 °C, unless otherwise noted)

Symbol	Parameter		Test conditions	Limits			Unit
				Min.	Typ.	Max.	
—	Resolution					8	Bits
—	Absolute accuracy	VCC = 4.0 to 5.5 V				1.0	%
		VCC = 3.0 to 4.0 V				2.5	
tsu	Setting time					3	μs
RO	Output resistor			1	2.5	4	kΩ
IVREF	Reference power source input current (Note)					3.2	mA

**Note:** Using one D-A converter, with the value in the D-A conversion register of the other D-A converter being “0016”, and excluding currents flowing through the A-D resistance ladder.

# APPENDIX

## 3.1 Electrical characteristics

### 3.1.6 Timing requirements and Switching characteristics

**Table 3.1.6 Timing requirements (1)** ( $V_{CC} = 4.0$  to  $5.5$  V,  $V_{SS} = 0$  V,  $T_a = -20$  to  $85$  °C, unless otherwise noted)

Symbol	Parameter	Limits			Unit
		Min.	Typ.	Max.	
tw(RESET)	Reset input "L" pulse width	2			μs
tc(XIN)	External clock input cycle time	125			ns
twH(XIN)	External clock input "H" pulse width	50			ns
twL(XIN)	External clock input "L" pulse width	50			ns
tc(CNTR)	CNTR0, CNTR1 input cycle time	200			ns
twH(CNTR)	CNTR0, CNTR1 input "H" pulse width	80			ns
twH(INT)	INT0 to INT4 input "H" pulse width	80			ns
twL(CNTR)	CNTR0, CNTR1 input "L" pulse width	80			ns
twL(INT)	INT0 to INT4 input "L" pulse width	80			ns
tc(SCLK1)	Serial I/O1 clock input cycle time (Note)	800			ns
tc(SCLK2)	Serial I/O2 clock input cycle time	1000			ns
twH(SCLK1)	Serial I/O1 clock input "H" pulse width (Note)	370			ns
twH(SCLK2)	Serial I/O2 clock input "H" pulse width	400			ns
twL(SCLK1)	Serial I/O1 clock input "L" pulse width (Note)	370			ns
twL(SCLK2)	Serial I/O2 clock input "L" pulse width	400			ns
tsu(RxD-SCLK1)	Serial I/O1 input set up time	220			ns
tsu(SIN2-SCLK2)	Serial I/O2 input set up time	200			ns
th(SCLK1-RxD)	Serial I/O1 input hold time	100			ns
th(SCLK2-SIN2)	Serial I/O2 input hold time	200			ns

**Note:** When bit 6 of address 001A16 is "1". Divide this value by four when bit 6 of address 001A16 is "0".

**Table 3.1.7 Timing requirements (2)** ( $V_{CC} = 3.0$  to  $4.0$  V,  $V_{SS} = 0$  V,  $T_a = -20$  to  $85$  °C, unless otherwise noted)

Symbol	Parameter	Limits			Unit
		Min.	Typ.	Max.	
tw(RESET)	Reset input "L" pulse width	2			μs
tc(XIN)	External clock input cycle time	500/ (3 V <sub>CC</sub> -8)			ns
twH(XIN)	External clock input "H" pulse width	200/ (3 V <sub>CC</sub> -8)			ns
twL(XIN)	External clock input "L" pulse width	200/ (3 V <sub>CC</sub> -8)			ns
tc(CNTR)	CNTR0, CNTR1 input cycle time	500			ns
twH(CNTR)	CNTR0, CNTR1 input "H" pulse width	230			ns
twH(INT)	INT0 to INT4 input "H" pulse width	230			ns
twL(CNTR)	CNTR0, CNTR1 input "L" pulse width	230			ns
twL(INT)	INT0 to INT4 input "L" pulse width	230			ns
tc(SCLK1)	Serial I/O1 clock input cycle time (Note)	2000			ns
tc(SCLK2)	Serial I/O2 clock input cycle time	2000			ns
twH(SCLK1)	Serial I/O1 clock input "H" pulse width (Note)	950			ns
twH(SCLK2)	Serial I/O2 clock input "H" pulse width	950			ns
twL(SCLK1)	Serial I/O1 clock input "L" pulse width (Note)	950			ns
twL(SCLK2)	Serial I/O2 clock input "L" pulse width	950			ns
tsu(RxD-SCLK1)	Serial I/O1 input set up time	400			ns
tsu(SIN2-SCLK2)	Serial I/O2 input set up time	400			ns
th(SCLK1-RxD)	Serial I/O1 input hold time	200			ns
th(SCLK2-SIN2)	Serial I/O2 input hold time	300			ns

**Note :** When bit 6 of address 001A16 is "1". Divide this value by four when bit 6 of address 001A16 is "0".

## 3.1 Electrical characteristics

**Table 3.1.8 Switching characteristics (1)** ( $V_{CC} = 4.0$  to  $5.5$  V,  $V_{SS} = 0$  V,  $T_a = -20$  to  $85$  °C, unless otherwise noted)

Symbol	Parameter	Test conditions	Limits			Unit
			Min.	Typ.	Max.	
$t_{wH}(S_{CLK1})$	Serial I/O1 clock output "H" pulse width	Fig. 3.1.1	$t_c(S_{CLK1})/2-30$			ns
$t_{wL}(S_{CLK1})$	Serial I/O1 clock output "L" pulse width		$t_c(S_{CLK1})/2-30$			ns
$t_d(S_{CLK1}-TxD)$	Serial I/O1 output delay time (Note 1)				140	ns
$t_v(S_{CLK1}-TxD)$	Serial I/O1 output valid time (Note 1)		-30			ns
$t_r(S_{CLK1})$	Serial I/O1 clock output rising time				30	ns
$t_f(S_{CLK1})$	Serial I/O1 clock output falling time				30	ns
$t_{wH}(S_{CLK2})$	Serial I/O2 clock output "H" pulse width	Fig. 3.1.2	$t_c(S_{CLK2})/2-160$			ns
$t_{wL}(S_{CLK2})$	Serial I/O2 clock output "L" pulse width		$t_c(S_{CLK2})/2-160$			ns
$t_d(S_{CLK2}-S_{OUT2})$	Serial I/O2 output delay time				200	ns
$t_v(S_{CLK2}-S_{OUT2})$	Serial I/O2 output valid time		0			ns
$t_f(S_{CLK2})$	Serial I/O2 clock output falling time				40	ns
$t_r(CMOS)$	CMOS output rising time (Note 2)		Fig. 3.1.1		10	30
$t_f(CMOS)$	CMOS output falling time (Note 2)			10	30	ns

**Note1:** When the P45/TxD P-channel output disable bit of the UART control register (bit 4 of address 001B16) is "0".

**2:** Pins XOUT and P70–P77 are excluded.

**Table 3.1.9 Switching characteristics (2)** ( $V_{CC} = 3.0$  to  $4.0$  V,  $V_{SS} = 0$  V,  $T_a = -20$  to  $85$  °C, unless otherwise noted)

Symbol	Parameter	Test conditions	Limits			Unit
			Min.	Typ.	Max.	
$t_{wH}(S_{CLK1})$	Serial I/O1 clock output "H" pulse width	Fig. 3.1.1	$t_c(S_{CLK1})/2-50$			ns
$t_{wL}(S_{CLK1})$	Serial I/O1 clock output "L" pulse width		$t_c(S_{CLK1})/2-50$			ns
$t_d(S_{CLK1}-TxD)$	Serial I/O1 output delay time (Note 1)				350	ns
$t_v(S_{CLK1}-TxD)$	Serial I/O1 output valid time (Note 1)		-30			ns
$t_r(S_{CLK1})$	Serial I/O1 clock output rising time				50	ns
$t_f(S_{CLK1})$	Serial I/O1 clock output falling time				50	ns
$t_{wH}(S_{CLK2})$	Serial I/O2 clock output "H" pulse width	Fig. 3.1.2	$t_c(S_{CLK2})/2-240$			ns
$t_{wL}(S_{CLK2})$	Serial I/O2 clock output "L" pulse width		$t_c(S_{CLK2})/2-240$			ns
$t_d(S_{CLK2}-S_{OUT2})$	Serial I/O2 output delay time				400	ns
$t_v(S_{CLK2}-S_{OUT2})$	Serial I/O2 output valid time		0			ns
$t_f(S_{CLK2})$	Serial I/O2 clock output falling time				50	ns
$t_r(CMOS)$	CMOS output rising time (Note 2)		Fig. 3.1.1		20	50
$t_f(CMOS)$	CMOS output falling time (Note 2)			20	50	ns

**Note1:** When the P45/TxD P-channel output disable bit of the UART control register (bit 4 of address 001B16) is "0".

**2:** Pins XOUT and P70–P77 are excluded.

# APPENDIX

## 3.1 Electrical characteristics

**Table 3.1.10 Timing requirements in memory expansion mode and microprocessor mode (1)**

(V<sub>CC</sub> = 4.0 to 5.5 V, V<sub>SS</sub> = 0 V, T<sub>a</sub> = -20 to 85 °C, unless otherwise noted)

Symbol	Parameter	Limits			Unit
		Min.	Typ.	Max.	
t <sub>su</sub> (ONW-φ)	Before φ ONW input set up time	-20			ns
t <sub>h</sub> (φ-ONW)	After φ ONW input hold time	-20			ns
t <sub>su</sub> (DB-φ)	Before φ data bus set up time	60			ns
t <sub>h</sub> (φ-DB)	After φ data bus hold time	0			ns
t <sub>su</sub> (ONW-RD) t <sub>su</sub> (ONW-WR)	Before RD ONW input set up time Before WR ONW input set up time	-20			ns
t <sub>h</sub> (RD-ONW) t <sub>h</sub> (WR-ONW)	After RD ONW input hold time After WR ONW input hold time	-20			ns
t <sub>su</sub> (DB-RD)	Before RD data bus set up time	65			ns
t <sub>h</sub> (RD-DB)	After RD data bus hold time	0			ns

**Table 3.1.11 Switching characteristics in memory expansion mode and microprocessor mode (1)**

(V<sub>CC</sub> = 4.0 to 5.5 V, V<sub>SS</sub> = 0 V, T<sub>a</sub> = -20 to 85 °C, unless otherwise noted)

Symbol	Parameter	Test conditions	Limits			Unit	
			Min.	Typ.	Max.		
t <sub>c</sub> (φ)	φ clock cycle time	Fig. 3.1.1		2t <sub>c</sub> (X <sub>IN</sub> )		ns	
t <sub>wH</sub> (φ)	φ clock "H" pulse width		t <sub>c</sub> (X <sub>IN</sub> )-10			ns	
t <sub>wL</sub> (φ)	φ clock "L" pulse width		t <sub>c</sub> (X <sub>IN</sub> )-10			ns	
t <sub>d</sub> (φ-AH)	After φ AD15-AD8 delay time			20	40	ns	
t <sub>v</sub> (φ-AH)	After φ AD15-AD8 valid time			6	10	ns	
t <sub>d</sub> (φ-AL)	After φ AD7-AD0 delay time				25	45	ns
t <sub>v</sub> (φ-AL)	After φ AD7-AD0 valid time			6	10	ns	
t <sub>d</sub> (φ-SYNC)	SYNC delay time				20	ns	
t <sub>v</sub> (φ-SYNC)	SYNC valid time				10	ns	
t <sub>d</sub> (φ-WR)	RD and WR delay time				10	20	ns
t <sub>v</sub> (φ-WR)	RD and WR valid time			3	5	10	ns
t <sub>d</sub> (φ-DB)	After φ data bus delay time				20	70	ns
t <sub>v</sub> (φ-DB)	After φ data bus valid time			15		ns	
t <sub>wL</sub> (RD) t <sub>wL</sub> (WR)	RD pulse width, WR pulse width RD pulse width, WR pulse width (When one-wait is valid)			t <sub>c</sub> (X <sub>IN</sub> )-10		ns	
t <sub>d</sub> (AH-RD) t <sub>d</sub> (AH-WR)	After AD15-AD8 RD delay time After AD15-AD8 WR delay time			t <sub>c</sub> (X <sub>IN</sub> )-35	t <sub>c</sub> (X <sub>IN</sub> )-15	ns	
t <sub>d</sub> (AL-RD) t <sub>d</sub> (AL-WR)	After AD7-AD0 RD delay time After AD7-AD0 WR delay time			t <sub>c</sub> (X <sub>IN</sub> )-40	t <sub>c</sub> (X <sub>IN</sub> )-20	ns	
t <sub>v</sub> (RD-AH) t <sub>v</sub> (WR-AH)	After RD AD15-AD8 valid time After WR AD15-AD8 valid time			0	5	ns	
t <sub>v</sub> (RD-AL) t <sub>v</sub> (WR-AL)	After RD AD7-AD0 valid time After WR AD7-AD0 valid time			0	5	ns	
t <sub>d</sub> (WR-DB)	After WR data bus delay time				15	65	ns
t <sub>v</sub> (WR-DB)	After WR data bus valid time			10		ns	
t <sub>d</sub> (RESET-RESETO <sub>UT</sub> )	RESETO <sub>UT</sub> output delay time (Note 1)				200	ns	
t <sub>v</sub> (φ-RESET)	RESETO <sub>UT</sub> output valid time (Note 1)		0		200	ns	

**Note 1:** The RESETO<sub>UT</sub> output goes "H" in sync with the fall of the φ clock that is anywhere between about 8 cycle and 13 cycles after the RESET input goes "H".

## 3.1 Electrical characteristics

**Table 3.1.12 Timing requirements in memory expansion mode and microprocessor mode (2)**

(VCC = 3.0 V, VSS = 0 V, Ta = -20 to 85 °C, unless otherwise noted)

Symbol	Parameter	Limits			Unit
		Min.	Typ.	Max.	
tsu(ONW-φ)	Before φ ONW input set up time	-20			ns
th(φ-ONW)	After φ ONW input hold time	-20			ns
tsu(DB-φ)	Before φ data bus set up time	180			ns
th(φ-DB)	After φ data bus hold time	0			ns
tsu(ONW-RD) tsu(ONW-WR)	Before RD ONW input set up time Before WR ONW input set up time	-20			ns
th(RD-ONW) th(WR-ONW)	After RD ONW input hold time After WR ONW input hold time	-20			ns
tsu(DB-RD)	Before RD data bus set up time	185			ns
th(RD-DB)	After RD data bus hold time	0			ns

**Table 3.1.13 Switching characteristics in memory expansion mode and microprocessor mode (2)**

(VCC = 3.0 V, VSS = 0 V, Ta = -20 to 85 °C, unless otherwise noted)

Symbol	Parameter	Test conditions	Limits			Unit
			Min.	Typ.	Max.	
tc(φ)	φ clock cycle time	Fig. 3.1.1		2tc(XIN)		ns
twH(φ)	φ clock "H" pulse width		tc(XIN)-20			ns
twL(φ)	φ clock "L" pulse width		tc(XIN)-20			ns
td(φ-AH)	After φ AD15-AD8 delay time				150	ns
tv(φ-AH)	After φ AD15-AD8 valid time		10	15		ns
td(φ-AL)	After φ AD7-AD0 delay time				150	ns
tv(φ-AL)	After φ AD7-AD0 valid time		10	15		ns
td(φ-SYNC)	SYNC delay time			40		ns
tv(φ-SYNC)	SYNC valid time			20		ns
td(φ-WR)	RD and WR delay time			15	25	ns
tv(φ-WR)	RD and WR valid time		3	7	15	ns
td(φ-DB)	After φ data bus delay time				200	ns
tv(φ-DB)	After φ data bus valid time		15			ns
twL(RD) twL(WR)	RD pulse width, WR pulse width RD pulse width, WR pulse width (When one-wait is valid)		tc(XIN)-20			ns
td(AH-RD) td(AH-WR)	After AD15-AD8 RD delay time After AD15-AD8 WR delay time		tc(XIN)-145			ns
td(AL-RD) td(AL-WR)	After AD7-AD0 RD delay time After AD7-AD0 WR delay time		tc(XIN)-145			ns
tv(RD-AH) tv(WR-AH)	After RD AD15-AD8 valid time After WR AD15-AD8 valid time		5	10		ns
tv(RD-AL) tv(WR-AL)	After RD AD7-AD0 valid time After WR AD7-AD0 valid time		5	10		ns
td(WR-DB)	After WR data bus delay time				195	ns
tv(WR-DB)	After WR data bus valid time		10			ns
td(RESET-RESETOut)	RESETOut output delay time (Note 1)			300	ns	
tv(φ-RESET)	RESETOut output valid time (Note 1)	0		300	ns	

**Note1:** The RESETOut output goes "H" in sync with the fall of the φ clock that is anywhere between about 8 cycle and 13 cycles after the RESET input goes "H".

# APPENDIX

## 3.1 Electrical characteristics

### 3.1.7 Absolute maximum ratings (Extended operating temperature version)

Table 3.1.14 Absolute maximum ratings (Extended operating temperature version)

Symbol	Parameter	Conditions	Ratings	Unit
V <sub>CC</sub>	Power source voltage	All voltage are based on V <sub>SS</sub> . Output transistors are cut off.	-0.3 to 7.0	V
V <sub>I</sub>	Input voltage P00–P07, P10–P17, P20–P27, P30–P37, P40–P47, P50–P57, P60–P67, P70–P77, P80–P87, V <sub>REF</sub>		-0.3 to V <sub>CC</sub> +0.3	V
V <sub>I</sub>	Input voltage $\overline{\text{RESET}}$ , X <sub>IN</sub>		-0.3 to V <sub>CC</sub> +0.3	V
V <sub>I</sub>	Input voltage CNV <sub>SS</sub>		-0.3 to 13	V
V <sub>O</sub>	Output voltage P00–P07, P10–P17, P20–P27, P30–P37, P40–P47, P50–P57, P60–P67, P70–P77, P80–P87, X <sub>OUT</sub>		-0.3 to V <sub>CC</sub> +0.3	V
P <sub>d</sub>	Power dissipation	T <sub>a</sub> = 25 °C	500	mW
T <sub>opr</sub>	Operating temperature		-40 to 85	°C
T <sub>stg</sub>	Storage temperature		-65 to 150	°C

### 3.1.8 Recommended operating conditions (Extended operating temperature version)

Table 3.1.15 Recommended operating conditions (Extended operating temperature version)

(V<sub>CC</sub> = 4.0 to 5.5 V, T<sub>a</sub> = -40 to 85 °C, unless otherwise noted)

Symbol	Parameter	Limits			Unit
		Min.	Typ.	Max.	
V <sub>CC</sub>	Power source voltage	4.0	5.0	5.5	V
V <sub>SS</sub>	Power source voltage		0		V
V <sub>REF</sub>	Analog reference voltage (when A-D converter is used)	2.0		V <sub>CC</sub>	V
	Analog reference voltage (when D-A converter is used)	4.0		V <sub>CC</sub>	V
AV <sub>SS</sub>	Analog power source voltage		0		V
V <sub>IA</sub>	Analog input voltage AN <sub>0</sub> –AN <sub>7</sub>	AV <sub>SS</sub>		V <sub>CC</sub>	V
V <sub>IH</sub>	"H" input voltage P00–P07, P10–P17, P20–P27, P30–P37, P40–P47, P50–P57, P60–P67, P70–P77, P80–P87	0.8 V <sub>CC</sub>		V <sub>CC</sub>	V
V <sub>IH</sub>	"H" input voltage $\overline{\text{RESET}}$ , X <sub>IN</sub> , CNV <sub>SS</sub>	0.8 V <sub>CC</sub>		V <sub>CC</sub>	V
V <sub>IL</sub>	"L" input voltage P00–P07, P10–P17, P20–P27, P30–P37, P40–P47, P50–P57, P60–P67, P70–P77, P80–P87	0		0.2 V <sub>CC</sub>	V
V <sub>IL</sub>	"L" input voltage $\overline{\text{RESET}}$ , CNV <sub>SS</sub>	0		0.2 V <sub>CC</sub>	V
V <sub>IL</sub>	"L" input voltage X <sub>IN</sub>	0		0.16 V <sub>CC</sub>	V
ΣI <sub>OH(peak)</sub>	"H" total peak output current P00–P07, P10–P17, P20–P27, P30–P37, P80–P87 (Note 1)			-80	mA
ΣI <sub>OH(peak)</sub>	"H" total peak output current P40–P47, P50–P57, P60–P67 (Note 1)			-80	mA
ΣI <sub>OL(peak)</sub>	"L" total peak output current P00–P07, P10–P17, P20–P27, P30–P37, P80–P87 (Note 1)			80	mA
ΣI <sub>OL(peak)</sub>	"L" total peak output current P40–P47, P50–P57, P60–P67, P70–P77 (Note 1)			80	mA
ΣI <sub>OH(avg)</sub>	"H" total average output current P00–P07, P10–P17, P20–P27, P30–P37, P80–P87 (Note 1)			-40	mA
ΣI <sub>OH(avg)</sub>	"H" total average output current P40–P47, P50–P57, P60–P67 (Note 1)			-40	mA
ΣI <sub>OL(avg)</sub>	"L" total average output current P00–P07, P10–P17, P20–P27, P30–P37, P80–P87 (Note 1)			40	mA
ΣI <sub>OL(avg)</sub>	"L" total average output current P40–P47, P50–P57, P60–P67, P70–P77 (Note 1)			40	mA
I <sub>OH(peak)</sub>	"H" peak output current P00–P07, P10–P17, P20–P27, P30–P37, P40–P47, P50–P57, P60–P67, P80–P87 (Note 2)			-10	mA
I <sub>OL(peak)</sub>	"L" peak output current P00–P07, P10–P17, P20–P27, P30–P37, P40–P47, P50–P57, P60–P67, P70–P77, P80–P87 (Note 2)			10	mA
I <sub>OH(avg)</sub>	"H" average output current P00–P07, P10–P17, P20–P27, P30–P37, P40–P47, P50–P57, P60–P67, P80–P87 (Note 3)			-5	mA
I <sub>OL(avg)</sub>	"L" average output current P00–P07, P10–P17, P20–P27, P30–P37, P40–P47, P50–P57, P60–P67, P70–P77, P80–P87 (Note 3)			5	mA
f(X <sub>IN</sub> )	Internal clock oscillation frequency			8	MHz

**Note 1:** The total output current is the sum of all the currents flowing through all the applicable ports. The total average current is an average value measured over 100 ms. The total peak current is the peak value of all the currents.

**2:** The peak output current is the peak current flowing in each port.

**3:** The average output current I<sub>OL(avg)</sub>, I<sub>OH(avg)</sub> in an average value measured over 100 ms.

## 3.1 Electrical characteristics

### 3.1.9 Electrical characteristics (Extended operating temperature version)

**Table 3.1.16 Electrical characteristics (Extended operating temperature version)**

(V<sub>CC</sub> = 4.0 to 5.5 V, V<sub>SS</sub> = 0 V, T<sub>a</sub> = -40 to 85 °C, unless otherwise noted)

Symbol	Parameter	Test conditions	Limits			Unit
			Min.	Typ.	Max.	
V <sub>OH</sub>	"H" output voltage P00-P07, P10-P17, P20-P27, P30-P37, P40-P47, P50-P57, P60-P67, P80-P87 (Note 1)	I <sub>OH</sub> = -10 mA	V <sub>CC</sub> -2.0			V
V <sub>OL</sub>	"L" output voltage P00-P07, P10-P17, P20-P27, P30-P37, P40-P47, P50-P57, P60-P67, P70-P77, P80-P87	I <sub>OL</sub> = 10 mA			2.0	V
V <sub>T+</sub> - V <sub>T-</sub>	Hysteresis	CNTR0, CNTR1, INT0-INT4		0.4		V
V <sub>T+</sub> - V <sub>T-</sub>	Hysteresis	RxD, SCLK1, SIN2, SCLK2		0.5		V
V <sub>T+</sub> - V <sub>T-</sub>	Hysteresis	RESET		0.5		V
I <sub>IH</sub>	"H" input current P00-P07, P10-P17, P20-P27, P30-P37, P40-P47, P50-P57, P60-P67, P70-P77, P80-P87	V <sub>I</sub> = V <sub>CC</sub>			5.0	μA
I <sub>IH</sub>	"H" input current	RESET, CNV <sub>SS</sub>			5.0	μA
I <sub>IH</sub>	"H" input current	XIN		4		μA
I <sub>IL</sub>	"L" input current P00-P07, P10-P17, P20-P27, P30-P37, P40-P47, P50-P57, P60-P67, P70-P77, P80-P87	V <sub>I</sub> = V <sub>SS</sub>			-5.0	μA
I <sub>IL</sub>	"L" input current	RESET, CNV <sub>SS</sub>			-5.0	μA
I <sub>IL</sub>	"L" input current	XIN		-4		μA
V <sub>RAM</sub>	RAM hold voltage	When clock stopped	2.0		5.5	V
I <sub>CC</sub>	Power source current	f(XIN) = 8 MHz		6.4	13	mA
		f(XIN) = 5 MHz		4	8	
		When WIT instruction is executed with f(XIN) = 8 MHz		1.5		
		When WIT instruction is executed with f(XIN) = 5 MHz		1		
		When STP instruction is executed with clock stopped, output transistors isolated.	T <sub>a</sub> = 25 °C (Note 2)	0.1	1	μA
	T <sub>a</sub> = 85 °C (Note 2)		10			

**Note 1:** P<sub>45</sub> is measured when the P<sub>45</sub>/TxD P-channel output disable bit of the UART control register (bit 4 of address 001B16) is "0".

**2:** With output transistors isolated and A-D converter having completed conversion, and not including current flowing through V<sub>REF</sub> pin.

### 3.1.10 A-D converter characteristics (Extended operating temperature version)

**Table 3.1.17 A-D converter characteristics (Extended operating temperature version)**

(V<sub>CC</sub> = 4.0 to 5.5 V, V<sub>SS</sub> = AV<sub>SS</sub> = 0 V, V<sub>REF</sub> = 2.0 V to V<sub>CC</sub>, T<sub>a</sub> = -40 to 85 °C, unless otherwise noted)

Symbol	Parameter	Test conditions	Limits			Unit
			Min.	Typ.	Max.	
—	Resolution				8	Bits
—	Absolute accuracy (excluding quantization error)			±1	±2.5	LSB
t <sub>CONV</sub>	Conversion time				50	t <sub>C</sub> (φ)
RLADDER	Ladder resistor			35		kΩ
I <sub>VREF</sub>	Reference power source input current (Note)	V <sub>REF</sub> = 5.0 V	50	150	200	μA
I <sub>I(AD)</sub>	A-D port input current			0.5	5.0	μA

**Note:** When D-A conversion registers (addresses 003616 and 003716) contain "0016".



# APPENDIX

## 3.1 Electrical characteristics

---

### 3.1.11 D-A converter characteristics (Extended operating temperature version)

Table 3.1.18 D-A converter characteristics (Extended operating temperature version)

(VCC = 4.0 to 5.5 V, VSS = AVSS = 0 V, VREF = 3.0 V to VCC, Ta = -40 to 85 °C, unless otherwise noted)

Symbol	Parameter	Test conditions	Limits			Unit
			Min.	Typ.	Max.	
—	Resolution				8	Bits
—	Absolute accuracy				1.0	%
tsu	Setting time				3	μs
RO	Output resistor		1	2.5	4	kΩ
IVREF	Reference power source input current (Note)				3.2	mA

**Note:** Using one D-A converter, with the value in the D-A conversion register of the other D-A converter being “0016”, and excluding currents flowing through the A-D resistance ladder.

## 3.1 Electrical characteristics

### 3.1.12 Timing requirements and Switching characteristics (Extended operating temperature version)

**Table 3.1.19 Timing requirements (Extended operating temperature version)**

(VCC = 4.0 to 5.5 V, VSS = 0 V, Ta = -40 to 85 °C, unless otherwise noted)

Symbol	Parameter	Limits			Unit
		Min.	Typ.	Max.	
tw(RESET)	Reset input "L" pulse width	2			μs
tc(XIN)	External clock input cycle time	125			ns
twH(XIN)	External clock input "H" pulse width	50			ns
twL(XIN)	External clock input "L" pulse width	50			ns
tc(CNTR)	CNTR0, CNTR1 input cycle time	200			ns
twH(CNTR)	CNTR0, CNTR1 input "H" pulse width	80			ns
twH(INT)	INT0 to INT4 input "H" pulse width	80			ns
twL(CNTR)	CNTR0, CNTR1 input "L" pulse width	80			ns
twL(INT)	INT0 to INT4 input "L" pulse width	80			ns
tc(SCLK1)	Serial I/O1 clock input cycle time (Note)	800			ns
tc(SCLK2)	Serial I/O2 clock input cycle time	1000			ns
twH(SCLK1)	Serial I/O1 clock input "H" pulse width (Note)	370			ns
twH(SCLK2)	Serial I/O2 clock input "H" pulse width	400			ns
twL(SCLK1)	Serial I/O1 clock input "L" pulse width (Note)	370			ns
twL(SCLK2)	Serial I/O2 clock input "L" pulse width	400			ns
tsu(RxD-SCLK1)	Serial I/O1 input set up time	220			ns
tsu(SIN2-SCLK2)	Serial I/O2 input set up time	200			ns
th(SCLK1-RxD)	Serial I/O1 input hold time	100			ns
th(SCLK2-SIN2)	Serial I/O2 input hold time	200			ns

**Note:** When bit 6 of address 001A16 is "1". Divide this value by four when bit 6 of address 001A16 is "0".

**Table 3.1.20 Switching characteristics (Extended operating temperature version)**

(VCC = 4.0 to 5.5 V, VSS = 0 V, Ta = -40 to 85 °C, unless otherwise noted)

Symbol	Parameter	Test conditions	Limits			Unit
			Min.	Typ.	Max.	
twH(SCLK1)	Serial I/O1 clock output "H" pulse width	Fig. 3.1.1	tc(SCLK1)/2-30			ns
twL(SCLK1)	Serial I/O1 clock output "L" pulse width		tc(SCLK1)/2-30			ns
td(SCLK1-TxD)	Serial I/O1 output delay time (Note 1)				140	ns
tv(SCLK1-TxD)	Serial I/O1 output valid time (Note 1)		-30			ns
tr(SCLK1)	Serial I/O1 clock output rise time				30	ns
tf(SCLK1)	Serial I/O1 clock output fall time				30	ns
twH(SCLK2)	Serial I/O2 clock output "H" pulse width	Fig. 3.1.2	tc(SCLK2)/2-160			ns
twL(SCLK2)	Serial I/O2 clock output "L" pulse width		tc(SCLK2)/2-160			ns
td(SCLK2-SOUT2)	Serial I/O2 output delay time				200	ns
tv(SCLK2-SOUT2)	Serial I/O2 output valid time		0			ns
tf(SCLK2)	Serial I/O2 clock output fall time				40	ns
tr(CMOS)	CMOS output rise time (Note 2)		Fig. 3.1.1		10	30
tf(CMOS)	CMOS output fall time (Note 2)			10	30	ns

**Note1:** When the P45/TxD P-channel output disable bit of the UART control register (bit 4 of address 001B16) is "0".

**2:** Pins XOUT pin and P70-77 are excluded.

# APPENDIX

## 3.1 Electrical characteristics

**Table 3.1.21 Timing requirements in memory expansion mode and microprocessor mode**

(Extended operating temperature version) ( $V_{CC} = 4.0$  to  $5.5$  V,  $V_{SS} = 0$  V,  $T_a = -40$  to  $85$  °C, unless otherwise noted)

Symbol	Parameter	Limits			Unit
		Min.	Typ.	Max.	
$t_{su}(ONW-\phi)$	Before $\phi$ ONW input set up time	-20			ns
$t_{h}(\phi-ONW)$	After $\phi$ ONW input hold time	-20			ns
$t_{su}(DB-\phi)$	Before $\phi$ data bus set up time	60			ns
$t_{h}(\phi-DB)$	After $\phi$ data bus hold time	0			ns
$t_{su}(ONW-\overline{RD})$ $t_{su}(ONW-\overline{WR})$	Before $\overline{RD}$ ONW input set up time Before $\overline{WR}$ ONW input set up time	-20			ns
$t_{h}(\overline{RD}-ONW)$ $t_{h}(\overline{WR}-ONW)$	After $\overline{RD}$ ONW input hold time After $\overline{WR}$ ONW input hold time	-20			ns
$t_{su}(DB-\overline{RD})$	Before $\overline{RD}$ data bus set up time	65			ns
$t_{h}(\overline{RD}-DB)$	After $\overline{RD}$ data bus hold time	0			ns

**Table 3.1.22 Switching characteristics in memory expansion mode and microprocessor mode**

(Extended operating temperature version) ( $V_{CC} = 4.0$  to  $5.5$  V,  $V_{SS} = 0$  V,  $T_a = -40$  to  $85$  °C, unless otherwise noted)

Symbol	Parameter	Test conditions	Limits			Unit	
			Min.	Typ.	Max.		
$t_c(\phi)$	$\phi$ clock cycle time	Fig. 3.1.1		$2t_c(X_{IN})$		ns	
$t_{wH}(\phi)$	$\phi$ clock "H" pulse width		$t_c(X_{IN})-10$			ns	
$t_{wL}(\phi)$	$\phi$ clock "L" pulse width		$t_c(X_{IN})-10$			ns	
$t_d(\phi-AH)$	After $\phi$ AD15-AD8 delay time			20	40	ns	
$t_v(\phi-AH)$	After $\phi$ AD15-AD8 valid time			6	10	ns	
$t_d(\phi-AL)$	After $\phi$ AD7-AD0 delay time				25	45	ns
$t_v(\phi-AL)$	After $\phi$ AD7-AD0 valid time			6	10	ns	
$t_d(\phi-SYNC)$	SYNC delay time				20	ns	
$t_v(\phi-SYNC)$	SYNC valid time				10	ns	
$t_d(\phi-WR)$	RD and WR delay time				10	20	ns
$t_v(\phi-WR)$	RD and WR valid time			3	5	10	ns
$t_d(\phi-DB)$	After $\phi$ data bus delay time				20	70	ns
$t_v(\phi-DB)$	After $\phi$ data bus valid time			15		ns	
$t_{wL}(\overline{RD})$ $t_{wL}(\overline{WR})$	RD pulse width, WR pulse width RD pulse width, WR pulse width (When one-wait is valid)			$t_c(X_{IN})-10$ $3t_c(X_{IN})-10$		ns	
$t_d(AH-\overline{RD})$ $t_d(AH-\overline{WR})$	After AD15-AD8 RD delay time After AD15-AD8 WR delay time			$t_c(X_{IN})-35$	$t_c(X_{IN})-15$	ns	
$t_d(AL-\overline{RD})$ $t_d(AL-\overline{WR})$	After AD7-AD0 RD delay time After AD7-AD0 WR delay time			$t_c(X_{IN})-40$	$t_c(X_{IN})-20$	ns	
$t_v(\overline{RD}-AH)$ $t_v(\overline{WR}-AH)$	After RD AD15-AD8 valid time After WR AD15-AD8 valid time			0	5	ns	
$t_v(\overline{RD}-AL)$ $t_v(\overline{WR}-AL)$	After RD AD7-AD0 valid time After WR AD7-AD0 valid time			0	5	ns	
$t_d(\overline{WR}-DB)$	After WR data bus delay time				15	65	ns
$t_v(\overline{WR}-DB)$	After WR data bus valid time			10		ns	
$t_d(\overline{RESET}-\overline{RESET}_{OUT})$	RESET <sub>OUT</sub> output delay time (Note 1)					200	ns
$t_v(\phi-\overline{RESET})$	RESET <sub>OUT</sub> output valid time (Note 1)			0		200	ns

**Note 1:** The RESET<sub>OUT</sub> output goes "H" in sync with the fall of the  $\phi$  clock that is anywhere between about 8 cycle and 13 cycles after the RESET input goes "H".

### 3.1.13 Absolute maximum ratings (High-speed version)

**Table 3.1.23 Absolute maximum ratings (High-speed version)**

Symbol	Parameter	Conditions	Ratings	Unit	
VCC	Power source voltage	All voltages are based on Vss. Output transistors are cut off.	-0.3 to 7.0	V	
VI	Input voltage P00–P07, P10–P17, P20–P27, P30–P37, P40–P47, P50–P57, P60–P67, P70–P77, P80–P87, VREF, XIN		-0.3 to Vcc +0.3	V	
VI	Input voltage RESET		-0.3 to 7.0	V	
VI	Input voltage CNVss		Mask ROM version	-0.3 to 7.0	V
			PROM version	-0.3 to 13	V
VO	Output voltage P00–P07, P10–P17, P20–P27, P30–P37, P40–P47, P50–P57, P60–P67, P70–P77, P80–P87, XOUT		-0.3 to Vcc +0.3	V	
Pd	Power dissipation	Ta = 25 °C	500	mW	
Topr	Operating temperature		-20 to 85	°C	
Tstg	Storage temperature		-40 to 125	°C	

### 3.1.14 Recommended operating conditions (High-speed version)

**Table 3.1.24 Recommended operating conditions (High-speed version)**

(VCC = 2.7 to 5.5 V, Ta = -20 to 85 °C, unless otherwise noted)

Symbol	Parameter		Limits			Unit
			Min.	Typ.	Max.	
VCC	Power source voltage (f(XIN) ≤ 4.15 MHz)		2.7	5.0	5.5	V
	Power source voltage (f(XIN) = 10 MHz)		4.0	5.0	5.5	
VSS	Power source voltage			0		V
VREF	Analog reference voltage (when A-D converter is used)		2.0		Vcc	V
	Analog reference voltage (when D-A converter is used)		2.7		Vcc	
AVSS	Analog power source voltage			0		V
VIA	Analog input voltage	AN0–AN7	AVss		Vcc	V
VIH	"H" input voltage	P00–P07, P10–P17, P20–P27, P30–P37, P40–P47, P50–P57, P60–P67, P70–P77, P80–P87, RESET, XIN, CNVss	0.8 Vcc		Vcc	V
VIL	"L" input voltage	P00–P07, P10–P17, P20–P27, P30–P37, P40–P47, P50–P57, P60–P67, P70–P77, P80–P87, RESET, CNVss	0		0.2 Vcc	V
VIL	"L" input voltage	XIN	0		0.16 Vcc	V
ΣIOH(peak)	"H" total peak output current	P00–P07, P10–P17, P20–P27, P30–P37, P80–P87 (Note 1)			-80	mA
ΣIOH(peak)	"H" total peak output current	P40–P47, P50–P57, P60–P67 (Note 1)			-80	mA
ΣIOL(peak)	"L" total peak output current	P00–P07, P10–P17, P20–P27, P30–P37, P80–P87 (Note 1)			80	mA
ΣIOL(peak)	"L" total peak output current	P40–P47, P50–P57, P60–P67, P70–P77 (Note 1)			80	mA
ΣIOH(avg)	"H" total average output current	P00–P07, P10–P17, P20–P27, P30–P37, P80–P87 (Note 1)			-40	mA
ΣIOH(avg)	"H" total average output current	P40–P47, P50–P57, P60–P67 (Note 1)			-40	mA
ΣIOL(avg)	"L" total average output current	P00–P07, P10–P17, P20–P27, P30–P37, P80–P87 (Note 1)			40	mA
ΣIOL(avg)	"L" total average output current	P40–P47, P50–P57, P60–P67, P70–P77 (Note 1)			40	mA
IOH(peak)	"H" peak output current	P00–P07, P10–P17, P20–P27, P30–P37, P40–P47, P50–P57, P60–P67, P80–P87 (Note 2)			-10	mA
IOL(peak)	"L" peak output current	P00–P07, P10–P17, P20–P27, P30–P37, P40–P47, P50–P57, P60–P67, P70–P77, P80–P87 (Note 2)			10	mA
IOH(avg)	"H" average output current	P00–P07, P10–P17, P20–P27, P30–P37, P40–P47, P50–P57, P60–P67, P80–P87 (Note 3)			-5	mA
IOL(avg)	"L" average output current	P00–P07, P10–P17, P20–P27, P30–P37, P40–P47, P50–P57, P60–P67, P70–P77, P80–P87 (Note 3)			5	mA
f(XIN)	Internal clock oscillation frequency (4.0 V ≤ VCC ≤ 5.5 V)				10	MHz
	Internal clock oscillation frequency (2.7 V ≤ VCC ≤ 4.0 V)				4.5VCC-8	

**Note 1:** The total output current is the sum of all the currents flowing through all the applicable ports. The total average current is an average value measured over 100 ms. The total peak current is the peak value of all the currents.

**2:** The peak output current is the peak current flowing in each port.

**3:** The average output current IOL(avg), IOH(avg) in an average value measured over 100 ms.

# APPENDIX

## 3.1 Electrical characteristics

### 3.1.15 Electrical characteristics (High-speed version)

**Table 3.1.25 Electrical characteristics (High-speed version)** ( $V_{CC} = 2.7$  to  $5.5$  V,  $V_{SS} = 0$  V,  $T_a = -20$  to  $85$  °C, unless otherwise noted)

Symbol	Parameter	Test conditions	Limits			Unit	
			Min.	Typ.	Max.		
VOH	“H” output voltage P00–P07, P10–P17, P20–P27, P30–P37, P40–P47, P50–P57, P60–P67, P80–P87 (Note 1)	IOH = –10 mA VCC = 4.0 to 5.5 V	VCC–2.0			V	
			VCC–1.0				
VOL	“L” output voltage P00–P07, P10–P17, P20–P27, P30–P37, P40–P47, P50–P57, P60–P67, P70–P77, P80–P87	IOL = 10 mA VCC = 4.0 to 5.5 V			2.0	V	
					1.0		
VT+ – VT–	Hysteresis	CNTR0, CNTR1, INT0–INT4		0.4		V	
VT+ – VT–	Hysteresis	RxD, SCLK1, SIN2, SCLK2		0.5		V	
VT+ – VT–	Hysteresis	RESET		0.5		V	
IiH	“H” input current	P00–P07, P10–P17, P20–P27, P30–P37, P40–P47, P50–P57, P60–P67, P70–P77, P80–P87	Vi = VCC		5.0	μA	
IiH	“H” input current	RESET, CNVss	Vi = VCC		5.0	μA	
IiH	“H” input current	XIN	Vi = VCC	4		μA	
IiL	“L” input current	P00–P07, P10–P17, P20–P27, P30–P37, P40–P47, P50–P57, P60–P67, P70–P77, P80–P87, RESET, CNVss	Vi = VSS		–5.0	μA	
IiL	“L” input current	XIN	Vi = VSS	–4		μA	
VRAM	RAM hold voltage	With clock stopped	2.0		5.5	V	
ICC	Power source current		f(XIN) = 10 MHz, VCC = 5 V		8	16	mA
			f(XIN) = 4 MHz, VCC = 2.7 V		1.3	2	
			When WIT instruction is executed with f(XIN) = 10 MHz, VCC = 5 V		2		
			When WIT instruction is executed with f(XIN) = 4 MHz, VCC = 2.7 V		0.3		
			When STP instruction is executed with clock stopped, output transistors isolated.	Ta = 25 °C (Note 2)	0.1	1	μA
	Ta = 85 °C (Note 2)		10				

**Note 1:** P45 is measured when the P45/TxD P-channel output disable bit of the UART control register (bit 4 of address 001B16) is “0”.

**2:** With output transistors isolated and A-D converter having completed conversion, and not including current flowing through VREF pin.

### 3.1.16 A-D converter characteristics (High-speed version)

**Table 3.1.26 A-D converter characteristics (High-speed version)**

( $V_{CC} = 2.7$  to  $5.5$  V,  $V_{SS} = AV_{SS} = 0$  V,  $V_{REF} = 2.0$  V to  $V_{CC}$ ,  $T_a = -20$  to  $85$  °C, unless otherwise noted)

Symbol	Parameter	Test conditions	Limits			Unit
			Min.	Typ.	Max.	
—	Resolution				8	Bits
—	Absolute accuracy (excluding quantization error)			±1	±2.5	LSB
tCONV	Conversion time				50	tC(φ)
RLADDER	Ladder resistor			35		kΩ
IVREF	Reference power source input current (Note)	VREF = 5.0 V	50	150	200	μA
I(AD)	A-D port input current			0.5	5.0	μA

**Note:** When D-A conversion registers (addresses 003616 and 003716) contain “0016”.

## 3.1 Electrical characteristics

### 3.1.17 D-A converter characteristics (High-speed version)

**Table 3.1.27 D-A converter characteristics (High-speed version)**

(VCC = 2.7 to 5.5 V, VSS = AVSS = 0 V, VREF = 2.7 V to VCC, Ta = -20 to 85 °C, unless otherwise noted)

Symbol	Parameter		Test conditions	Limits			Unit
				Min.	Typ.	Max.	
—	Resolution					8	Bits
—	Absolute accuracy	VCC = 4.0 to 5.5 V				1.0	%
		VCC = 2.7 to 5.5 V				2.5	
tsu	Setting time					3	μs
RO	Output resistor			1	2.5	4	kΩ
IVREF	Reference power source input current (Note)					3.2	mA

**Note:** Using one D-A converter, with the value in the D-A conversion register of the other D-A converter being “0016”, and excluding currents flowing through the A-D resistance ladder.

# APPENDIX

## 3.1 Electrical characteristics

### 3.1.18 Timing requirements and Switching characteristics (High-speed version)

**Table 3.1.28 Timing requirements (1) (High-speed version)** ( $V_{CC} = 4.0$  to  $5.5$  V,  $V_{SS} = 0$  V,  $T_a = -20$  to  $85$  °C, unless otherwise noted)

Symbol	Parameter	Limits			Unit
		Min.	Typ.	Max.	
tw(RESET)	Reset input "L" pulse width	2			μs
tc(XIN)	External clock input cycle time	100			ns
twH(XIN)	External clock input "H" pulse width	40			ns
twL(XIN)	External clock input "L" pulse width	40			ns
tc(CNTR)	CNTR0, CNTR1 input cycle time	200			ns
twH(CNTR)	CNTR0, CNTR1 input "H" pulse width	80			ns
twH(INT)	INT0 to INT4 input "H" pulse width	80			ns
twL(CNTR)	CNTR0, CNTR1 input "L" pulse width	80			ns
twL(INT)	INT0 to INT4 input "L" pulse width	80			ns
tc(SCLK1)	Serial I/O1 clock input cycle time (Note)	800			ns
tc(SCLK2)	Serial I/O2 clock input cycle time	1000			ns
twH(SCLK1)	Serial I/O1 clock input "H" pulse width (Note)	370			ns
twH(SCLK2)	Serial I/O2 clock input "H" pulse width	400			ns
twL(SCLK1)	Serial I/O1 clock input "L" pulse width (Note)	370			ns
twL(SCLK2)	Serial I/O2 clock input "L" pulse width	400			ns
tsu(RxD-SCLK1)	Serial I/O1 input set up time	220			ns
tsu(SIN2-SCLK2)	Serial I/O2 input set up time	200			ns
th(SCLK1-RxD)	Serial I/O1 input hold time	100			ns
th(SCLK2-SIN2)	Serial I/O2 input hold time	200			ns

**Note:** When  $f(XIN) = 8$  MHz and bit 6 of address 001A16 is "1". Divide this value by four when  $f(XIN) = 8$  MHz and bit 6 of address 001A16 is "0".

**Table 3.1.29 Timing requirements (2) (High-speed version)** ( $V_{CC} = 2.7$  to  $4.0$  V,  $V_{SS} = 0$  V,  $T_a = -20$  to  $85$  °C, unless otherwise noted)

Symbol	Parameter	Limits			Unit
		Min.	Typ.	Max.	
tw(RESET)	Reset input "L" pulse width	2			μs
tc(XIN)	External clock input cycle time	1000/ (4.5 V <sub>CC</sub> -8)			ns
twH(XIN)	External clock input "H" pulse width	400/ (4.5 V <sub>CC</sub> -8)			ns
twL(XIN)	External clock input "L" pulse width	400/ (4.5 V <sub>CC</sub> -8)			ns
tc(CNTR)	CNTR0, CNTR1 input cycle time	500			ns
twH(CNTR)	CNTR0, CNTR1 input "H" pulse width	230			ns
twH(INT)	INT0 to INT4 input "H" pulse width	230			ns
twL(CNTR)	CNTR0, CNTR1 input "L" pulse width	230			ns
twL(INT)	INT0 to INT4 input "L" pulse width	230			ns
tc(SCLK1)	Serial I/O1 clock input cycle time (Note)	2000			ns
tc(SCLK2)	Serial I/O2 clock input cycle time	2000			ns
twH(SCLK1)	Serial I/O1 clock input "H" pulse width (Note)	950			ns
twH(SCLK2)	Serial I/O2 clock input "H" pulse width	950			ns
twL(SCLK1)	Serial I/O1 clock input "L" pulse width (Note)	950			ns
twL(SCLK2)	Serial I/O2 clock input "L" pulse width	950			ns
tsu(RxD-SCLK1)	Serial I/O1 input set up time	400			ns
tsu(SIN2-SCLK2)	Serial I/O2 input set up time	400			ns
th(SCLK1-RxD)	Serial I/O1 input hold time	200			ns
th(SCLK2-SIN2)	Serial I/O2 input hold time	300			ns

**Note:** When  $f(XIN) = 2$  MHz and bit 6 of address 001A16 is "1". Divide this value by four when  $f(XIN) = 2$  MHz and bit 6 of address 001A16 is "0".

## 3.1 Electrical characteristics

**Table 3.1.30 Switching characteristics (1) (High-speed version)**

(VCC = 4.0 to 5.5 V, VSS = 0 V, Ta = -20 to 85 °C, unless otherwise noted)

Symbol	Parameter	Test conditions	Limits			Unit
			Min.	Typ.	Max.	
twH(SCLK1)	Serial I/O1 clock output "H" pulse width	Fig. 3.1.1	tc(SCLK1)/2-30			ns
twL(SCLK1)	Serial I/O1 clock output "L" pulse width		tc(SCLK1)/2-30			ns
td(SCLK1-TxD)	Serial I/O1 output delay time (Note 1)				140	ns
tv(SCLK1-TxD)	Serial I/O1 output valid time (Note 1)		-30			ns
tr(SCLK1)	Serial I/O1 clock output rising time				30	ns
tf(SCLK1)	Serial I/O1 clock output falling time				30	ns
twH(SCLK2)	Serial I/O2 clock output "H" pulse width	Fig. 3.1.2	tc(SCLK2)/2-160			ns
twL(SCLK2)	Serial I/O2 clock output "L" pulse width		tc(SCLK2)/2-160			ns
td(SCLK2-SOUT2)	Serial I/O2 output delay time				200	ns
tv(SCLK2-SOUT2)	Serial I/O2 output valid time		0			ns
tf(SCLK2)	Serial I/O2 clock output falling time				30	ns
tr(CMOS)	CMOS output rising time (Note 2)	Fig. 3.1.1		10	30	ns
tf(CMOS)	CMOS output falling time (Note 2)			10	30	ns

**Note 1:** When the P45/TxD P-channel output disable bit of the UART control register (bit 4 of address 001B16) is "0".

**2:** XOUT pin is excluded.

**Table 3.1.31 Switching characteristics (2) (High-speed version)**

(VCC = 2.7 to 4.0 V, VSS = 0 V, Ta = -20 to 85 °C, unless otherwise noted)

Symbol	Parameter	Test conditions	Limits			Unit
			Min.	Typ.	Max.	
twH(SCLK1)	Serial I/O1 clock output "H" pulse width	Fig. 3.1.1	tc(SCLK1)/2-50			ns
twL(SCLK1)	Serial I/O1 clock output "L" pulse width		tc(SCLK1)/2-50			ns
td(SCLK1-TxD)	Serial I/O1 output delay time (Note 1)				350	ns
tv(SCLK1-TxD)	Serial I/O1 output valid time (Note 1)		-30			ns
tr(SCLK1)	Serial I/O1 clock output rising time				50	ns
tf(SCLK1)	Serial I/O1 clock output falling time				50	ns
twH(SCLK2)	Serial I/O2 clock output "H" pulse width	Fig. 3.1.2	tc(SCLK2)/2-240			ns
twL(SCLK2)	Serial I/O2 clock output "L" pulse width		tc(SCLK2)/2-240			ns
td(SCLK2-SOUT2)	Serial I/O2 output delay time				400	ns
tv(SCLK2-SOUT2)	Serial I/O2 output valid time		0			ns
tf(SCLK2)	Serial I/O2 clock output falling time				50	ns
tr(CMOS)	CMOS output rising time (Note 2)	Fig. 3.1.1		20	50	ns
tf(CMOS)	CMOS output falling time (Note 2)			20	50	ns

**Note 1:** When the P45/TxD P-channel output disable bit of the UART control register (bit 4 of address 001B16) is "0".

**2:** XOUT pin is excluded.



# APPENDIX

## 3.1 Electrical characteristics

**Table 3.1.32 Timing requirements in memory expansion mode and microprocessor mode (1) (High-speed version)**

(V<sub>CC</sub> = 4.0 to 5.5 V, V<sub>SS</sub> = 0 V, T<sub>a</sub> = -20 to 85 °C, unless otherwise noted)

Symbol	Parameter	Limits			Unit
		Min.	Typ.	Max.	
t <sub>su</sub> (ONW-φ)	Before φ ONW input set up time	-20			ns
t <sub>h</sub> (φ-ONW)	After φ ONW input hold time	-20			ns
t <sub>su</sub> (DB-φ)	Before φ data bus set up time	50	25		ns
t <sub>h</sub> (φ-DB)	After φ data bus hold time	0			ns
t <sub>su</sub> (ONW-RD) t <sub>su</sub> (ONW-WR)	Before RD ONW input set up time Before WR ONW input set up time	-20			ns
t <sub>h</sub> (RD-ONW) t <sub>h</sub> (WR-ONW)	After RD ONW input hold time After WR ONW input hold time	-20			ns
t <sub>su</sub> (DB-RD)	Before RD data bus set up time	50	25		ns
t <sub>h</sub> (RD-DB)	After RD data bus hold time	0			ns

**Table 3.1.33 Switching characteristics in memory expansion mode and microprocessor mode (1) (High-speed version)**

(V<sub>CC</sub> = 4.0 to 5.5 V, V<sub>SS</sub> = 0 V, T<sub>a</sub> = -20 to 85 °C, unless otherwise noted)

Symbol	Parameter	Test conditions	Limits			Unit	
			Min.	Typ.	Max.		
t <sub>c</sub> (φ)	φ clock cycle time	Fig. 3.1.1		2t <sub>c</sub> (X <sub>IN</sub> )		ns	
t <sub>wH</sub> (φ)	φ clock "H" pulse width		t <sub>c</sub> (X <sub>IN</sub> )-10			ns	
t <sub>wL</sub> (φ)	φ clock "L" pulse width		t <sub>c</sub> (X <sub>IN</sub> )-10			ns	
t <sub>d</sub> (φ-AH)	After φ AD15-AD8 delay time			16	35	ns	
t <sub>v</sub> (φ-AH)	After φ AD15-AD8 valid time			2	5	ns	
t <sub>d</sub> (φ-AL)	After φ AD7-AD0 delay time				20	40	ns
t <sub>v</sub> (φ-AL)	After φ AD7-AD0 valid time			2	5	ns	
t <sub>d</sub> (φ-SYNC)	SYNC delay time				16		ns
t <sub>v</sub> (φ-SYNC)	SYNC valid time				5		ns
t <sub>d</sub> (φ-DB)	After φ data bus delay time				15	30	ns
t <sub>v</sub> (φ-DB)	After φ data bus valid time			10			ns
t <sub>wL</sub> (RD) t <sub>wL</sub> (WR)	RD pulse width, WR pulse width RD pulse width, WR pulse width (When one-wait is valid)			t <sub>c</sub> (X <sub>IN</sub> )-10 3t <sub>c</sub> (X <sub>IN</sub> )-10			ns
t <sub>d</sub> (AH-RD) t <sub>d</sub> (AH-WR)	After AD15-AD8 RD delay time After AD15-AD8 WR delay time			t <sub>c</sub> (X <sub>IN</sub> )-35	t <sub>c</sub> (X <sub>IN</sub> )-16		ns
t <sub>d</sub> (AL-RD) t <sub>d</sub> (AL-WR)	After AD7-AD0 RD delay time After AD7-AD0 WR delay time			t <sub>c</sub> (X <sub>IN</sub> )-40	t <sub>c</sub> (X <sub>IN</sub> )-20		ns
t <sub>v</sub> (RD-AH) t <sub>v</sub> (WR-AH)	After RD AD15-AD8 valid time After WR AD15-AD8 valid time			2	5		ns
t <sub>v</sub> (RD-AL) t <sub>v</sub> (WR-AL)	After RD AD7-AD0 valid time After WR AD7-AD0 valid time			2	5		ns
t <sub>d</sub> (WR-DB)	After WR data bus delay time				15	30	ns
t <sub>v</sub> (WR-DB)	After WR data bus valid time			10			ns
t <sub>d</sub> (RESET-RESETO <sub>UT</sub> )	RESETO <sub>UT</sub> output delay time (Note 1)					200	ns
t <sub>v</sub> (φ-RESET)	RESETO <sub>UT</sub> output valid time (Note 1)			0		100	ns

**Note 1:** The RESETO<sub>UT</sub> output goes "H" in sync with the fall of the φ clock that is anywhere between about 8 cycle and 13 cycles after the RESET input goes "H".

## 3.1 Electrical characteristics

**Table 3.1.34 Timing requirements in memory expansion mode and microprocessor mode (2) (High-speed version)**

(VCC = 2.7 V, VSS = 0 V, Ta = -20 to 85 °C, unless otherwise noted)

Symbol	Parameter	Limits			Unit
		Min.	Typ.	Max.	
tsu(ONW-φ)	Before φ ONW input set up time	-20			ns
th(φ-ONW)	After φ ONW input hold time	-20			ns
tsu(DB-φ)	Before φ data bus set up time	120	60		ns
th(φ-DB)	After φ data bus hold time	0			ns
tsu(ONW-RD)	Before RD ONW input set up time	-20			ns
tsu(ONW-WR)	Before WR ONW input set up time				
th(RD-ONW)	After RD ONW input hold time	-20			ns
th(WR-ONW)	After WR ONW input hold time				
tsu(DB-RD)	Before RD data bus set up time	120	60		ns
th(RD-DB)	After RD data bus hold time	0			ns

**Table 3.1.35 Switching characteristics in memory expansion mode and microprocessor mode (2) (High-speed version)**

(VCC = 2.7 V, VSS = 0 V, Ta = -20 to 85 °C, unless otherwise noted)

Symbol	Parameter	Test conditions	Limits			Unit
			Min.	Typ.	Max.	
tc(φ)	φ clock cycle time	Fig. 3.1.1		2tc(XIN)		ns
twH(φ)	φ clock "H" pulse width		tc(XIN)-20			ns
twL(φ)	φ clock "L" pulse width		tc(XIN)-20			ns
td(φ-AH)	AD15-AD8 delay time			40	100	ns
tv(φ-AH)	AD15-AD8 valid time		5	10		ns
td(φ-AL)	AD7-AD0 delay time			50	100	ns
tv(φ-AL)	AD7-AD0 valid time		5	10		ns
td(φ-SYNC)	SYNC delay time			40		ns
tv(φ-SYNC)	SYNC valid time			10		ns
td(φ-DB)	Data bus delay time			30	80	ns
tv(φ-DB)	Data bus valid time		10			ns
twL(RD)	RD pulse width, WR pulse width		tc(XIN)-20			ns
twL(WR)	RD pulse width, WR pulse width (When one-wait is valid)		3tc(XIN)-20			ns
td(AH-RD)	After AD15-AD8 RD delay time		tc(XIN)-100	tc(XIN)-40		ns
td(AH-WR)	After AD15-AD8 WR delay time					
td(AL-RD)	After AD7-AD0 RD delay time		tc(XIN)-100	tc(XIN)-50		ns
td(AL-WR)	After AD7-AD0 WR delay time					
tv(RD-AH)	After RD AD15-AD8 valid time		5	10		ns
tv(WR-AH)	After WR AD15-AD8 valid time					
tv(RD-AL)	After RD AD7-AD0 valid time		5	10		ns
tv(WR-AL)	After WR AD7-AD0 valid time					
td(WR-DB)	After WR data bus delay time		30	80	ns	
tv(WR-DB)	After WR data bus valid time	10			ns	
td(RESET-RESETOut)	RESETOut output delay time (Note 1)			300	ns	
tv(φ-RESET)	RESETOut output valid time (Note 1)	0		150	ns	

**Note 1:** The RESETOut output goes "H" in sync with the rise of the φ clock that is anywhere between about 8 cycle and 13 cycles after the RESET input goes "H".

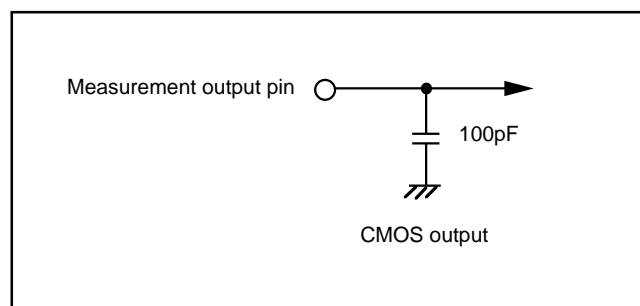

**Fig. 3.1.1 Circuit for measuring output switching characteristics (1)**

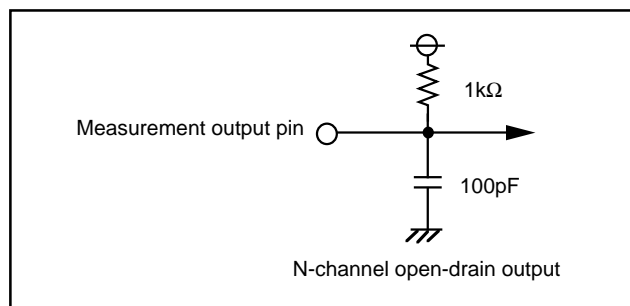

**Fig. 3.1.2 Circuit for measuring output switching characteristics (2)**

# APPENDIX

## 3.1 Electrical characteristics

### 3.1.19 Timing diagram

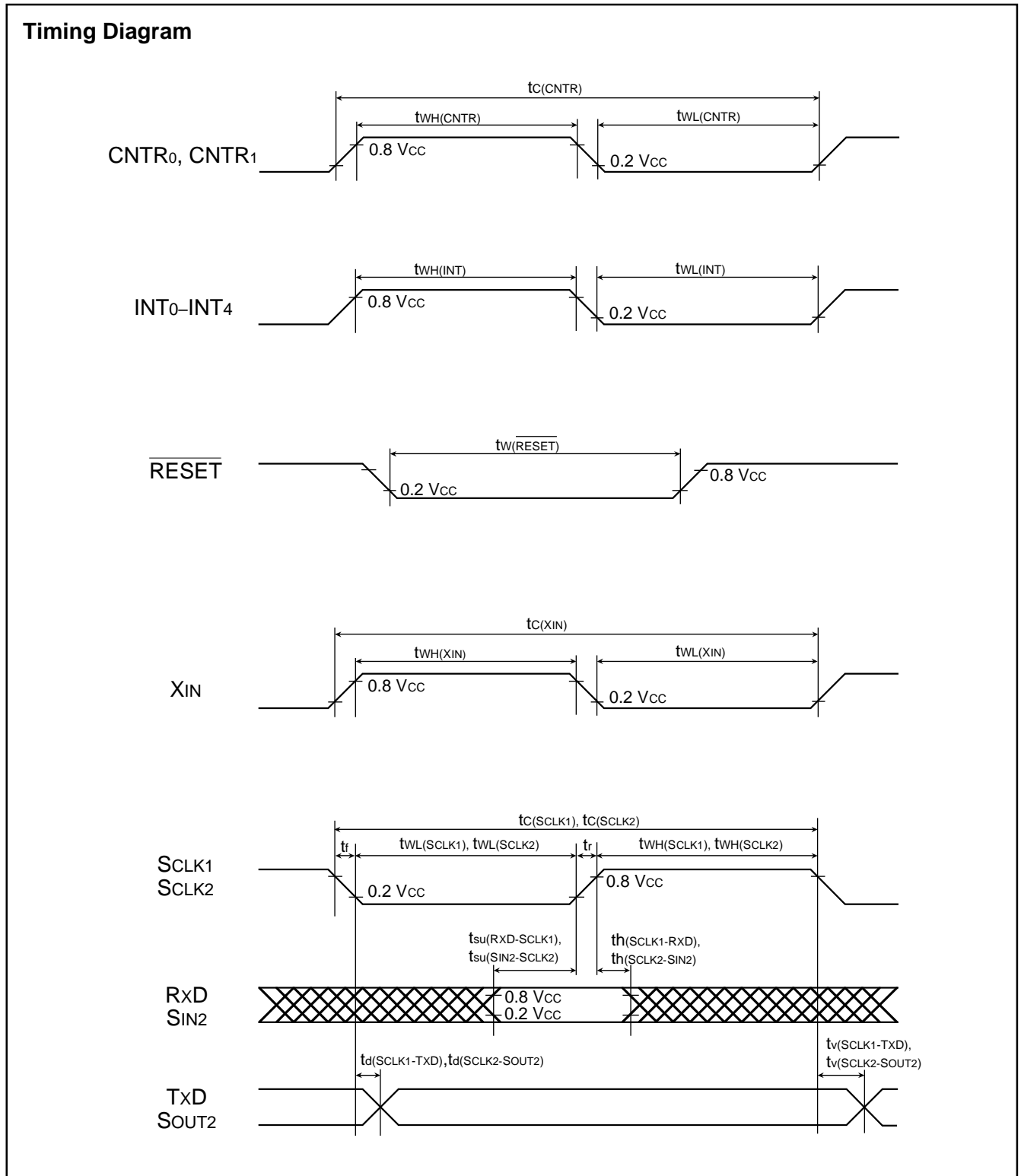
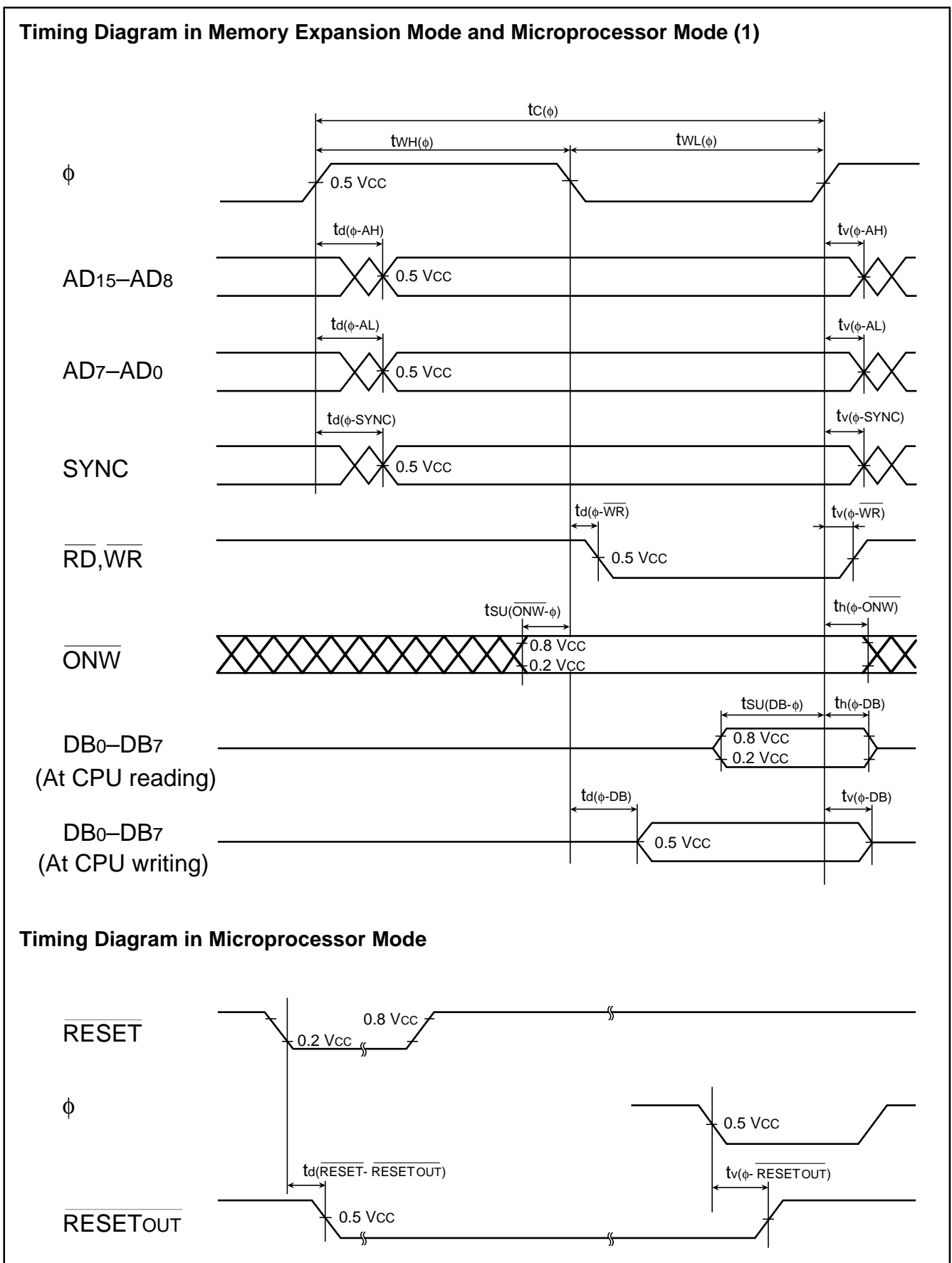

Fig. 3.1.3 Timing diagram (in single-chip mode)



**Timing Diagram in Microprocessor Mode**

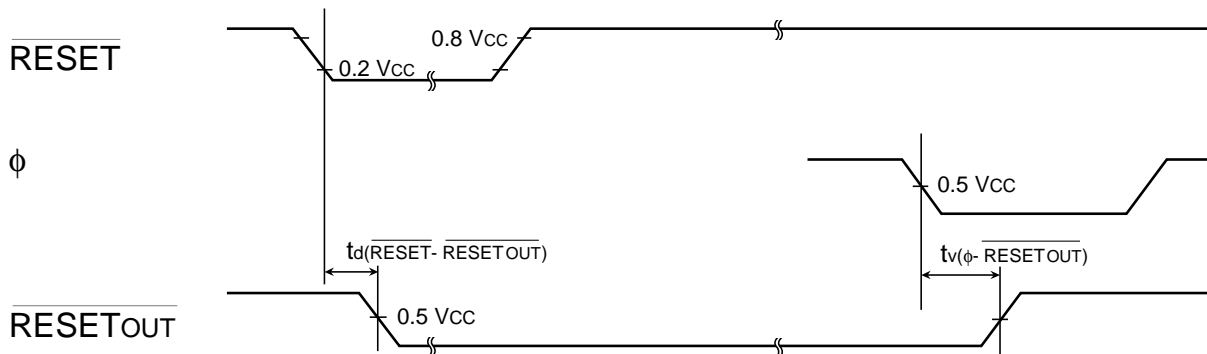

Fig. 3.1.4 Timing diagram (in memory expansion mode and microprocessor mode) (1)

# APPENDIX

## 3.1 Electrical characteristics

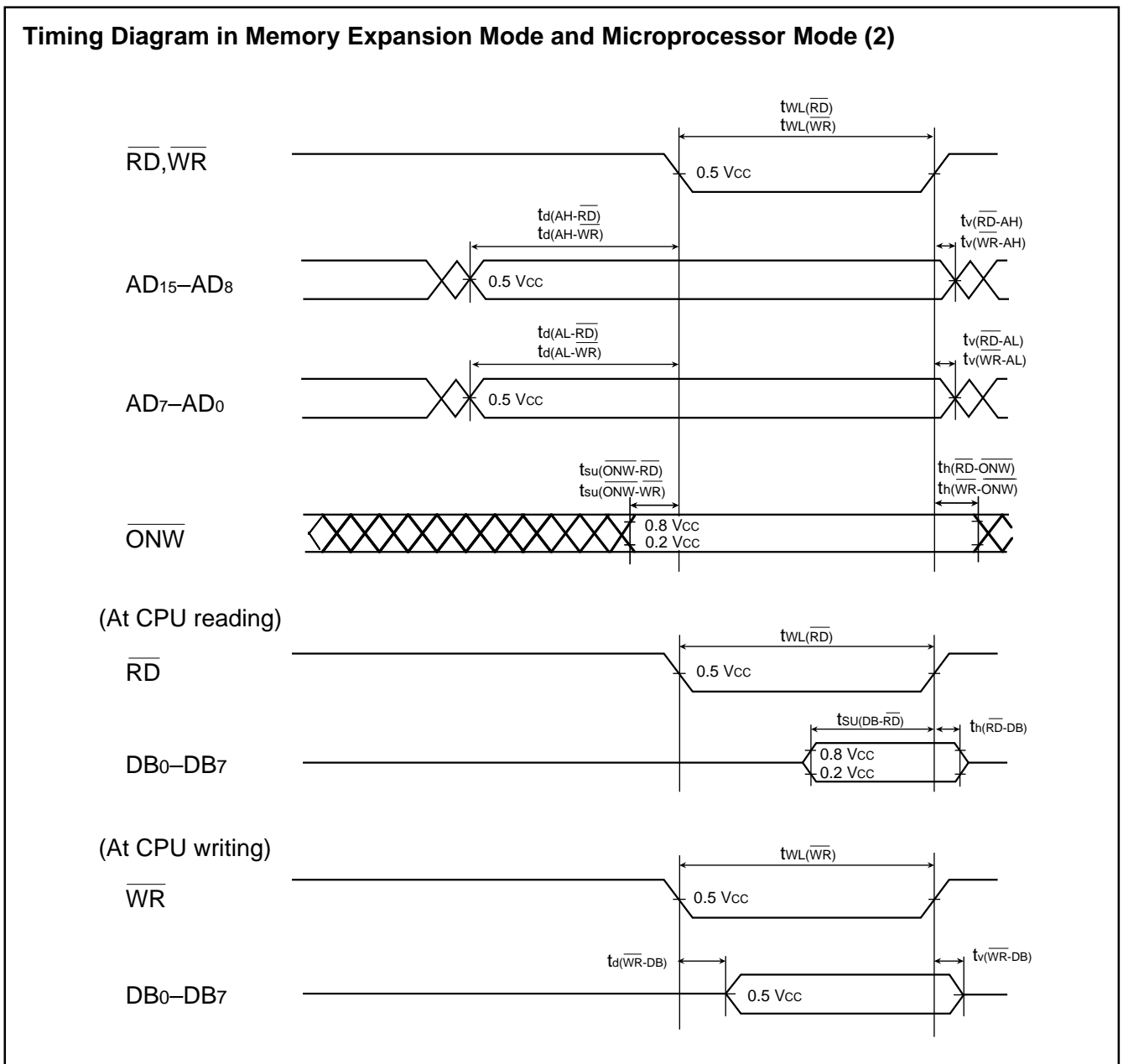

Fig. 3.1.5 Timing diagram (in memory expansion mode and microprocessor mode) (2)

### 3.2 Standard characteristics

#### 3.2.1 Power source current characteristic examples

Figures 3.2.1 and Figure 3.2.2 show power source current characteristic examples.

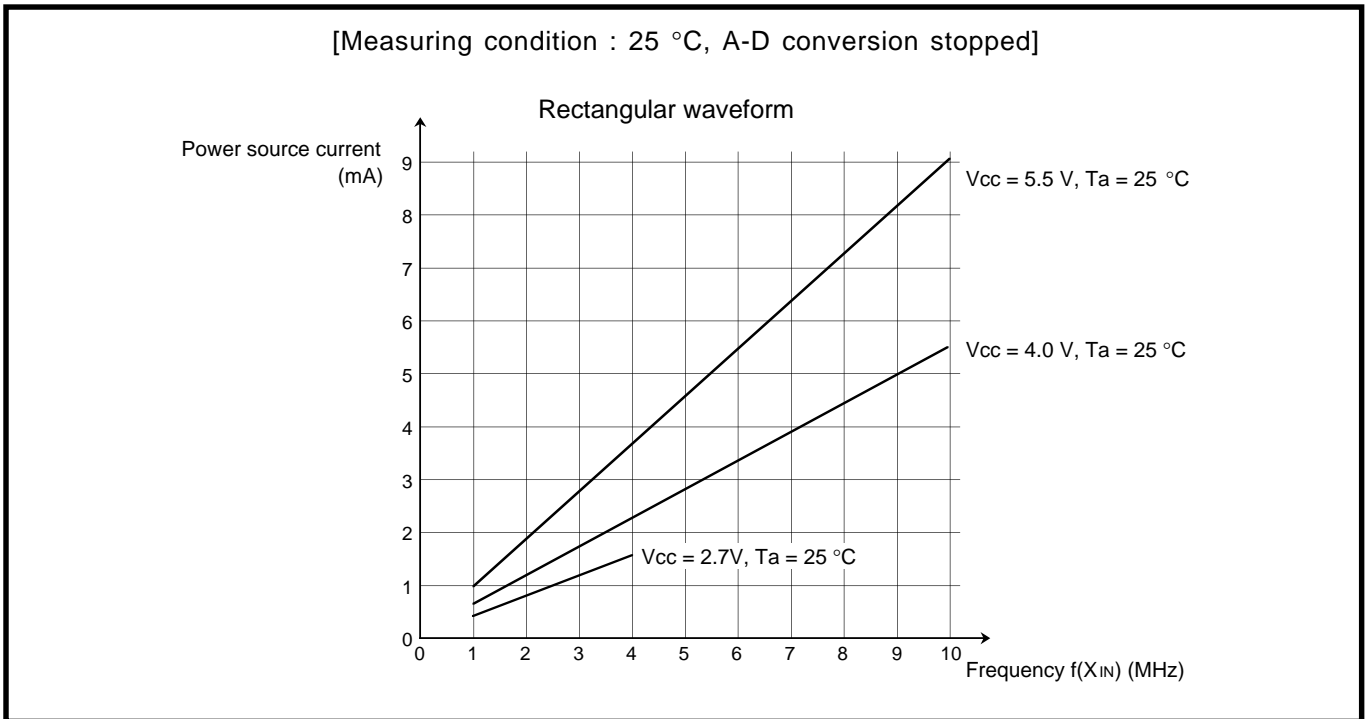

Fig. 3.2.1 Power source current characteristic example

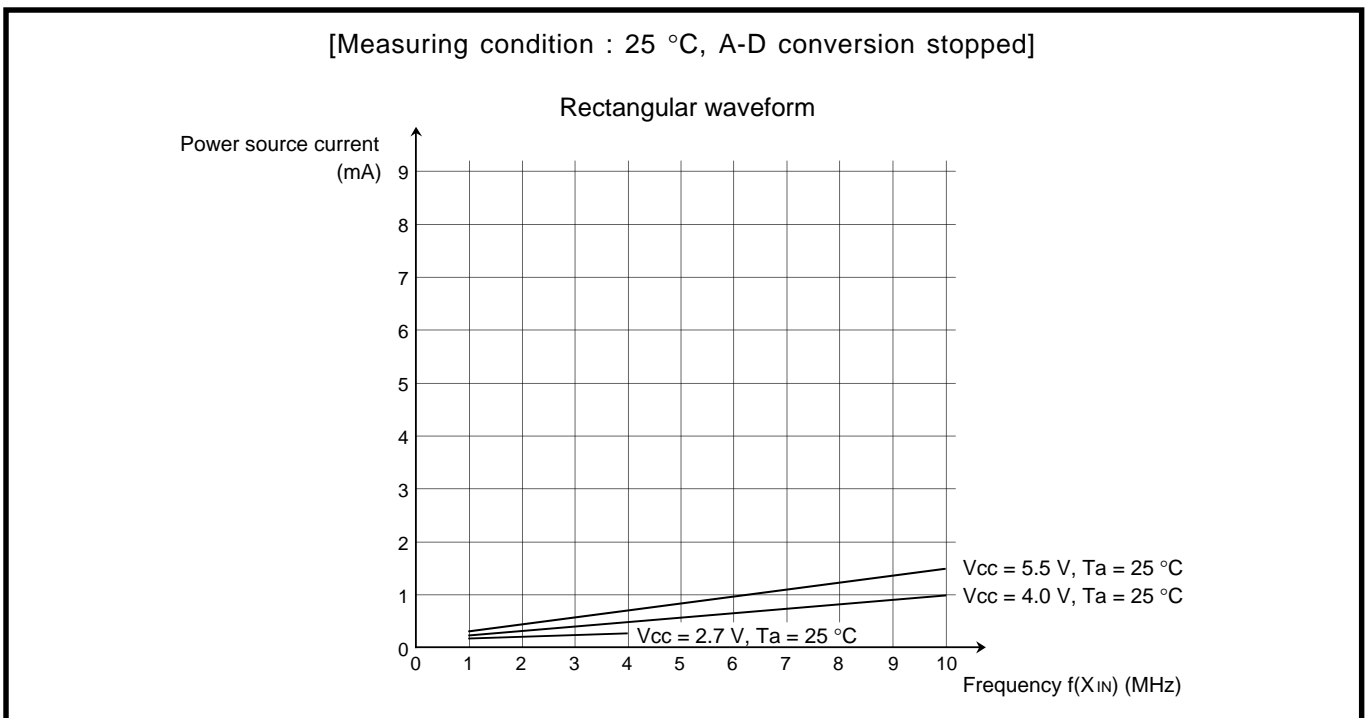

Fig. 3.2.2 Power source current characteristic example (in wait mode)

# APPENDIX

## 3.2 Standard characteristics

### 3.2.2 Port standard characteristic examples

Figures 3.2.3, Figure 3.2.4, Figure 3.2.5 and Figure 3.2.6 show port standard characteristic examples.

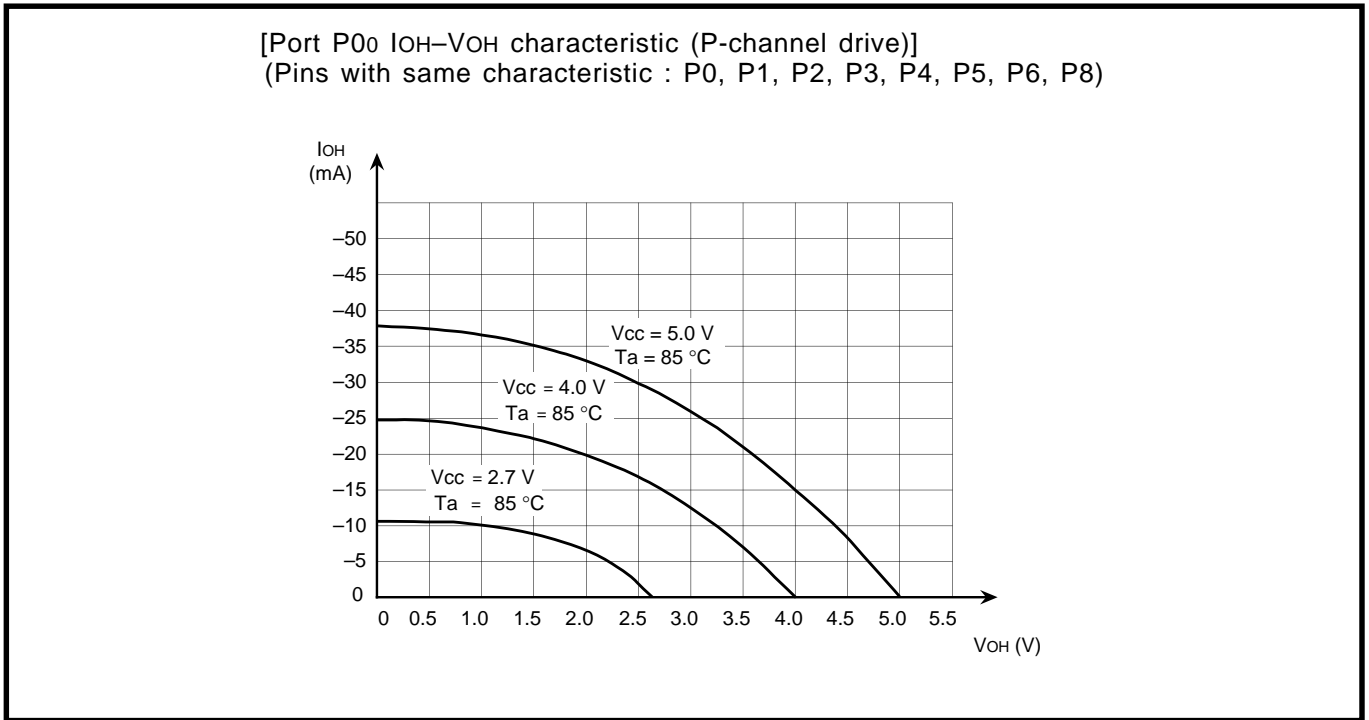

Fig. 3.2.3 Standard characteristic example of CMOS output port at P-channel drive (1)

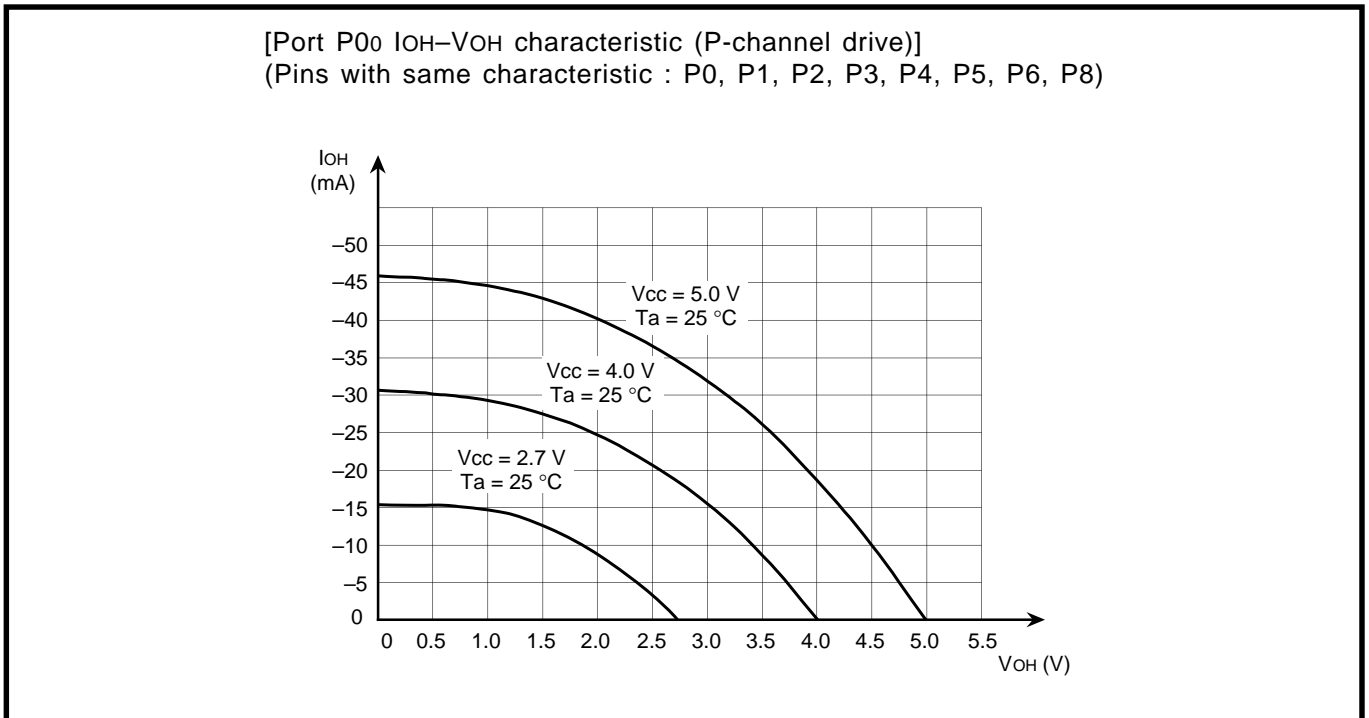

Fig. 3.2.4 Standard characteristic example of CMOS output port at P-channel drive (2)

[Port P0<sub>0</sub> IOL-VOL characteristic (N-channel drive)]

(Pins with same characteristic : P0, P1, P2, P3, P4, P5, P6, P7, P8)

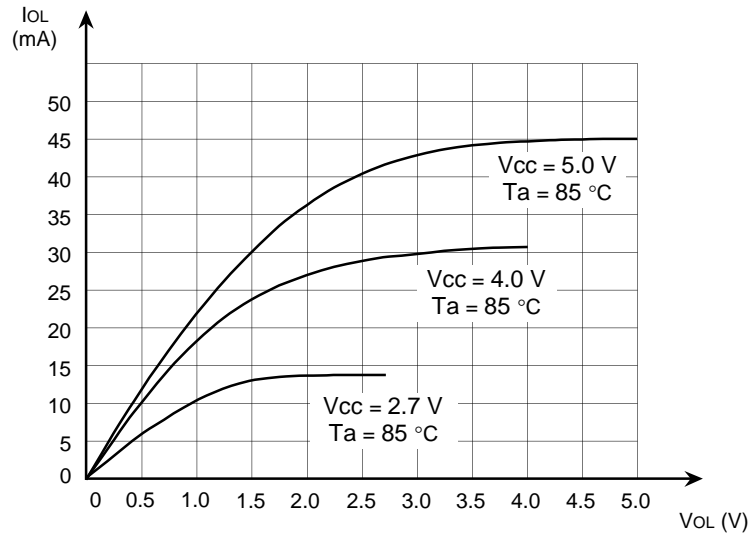

Fig. 3.2.5 Standard characteristic example of CMOS output port at N-channel drive (1)

[Port P0<sub>0</sub> IOL-VOL characteristic (N-channel drive)]

(Pins with same characteristic : P0, P1, P2, P3, P4, P5, P6, P7, P8)

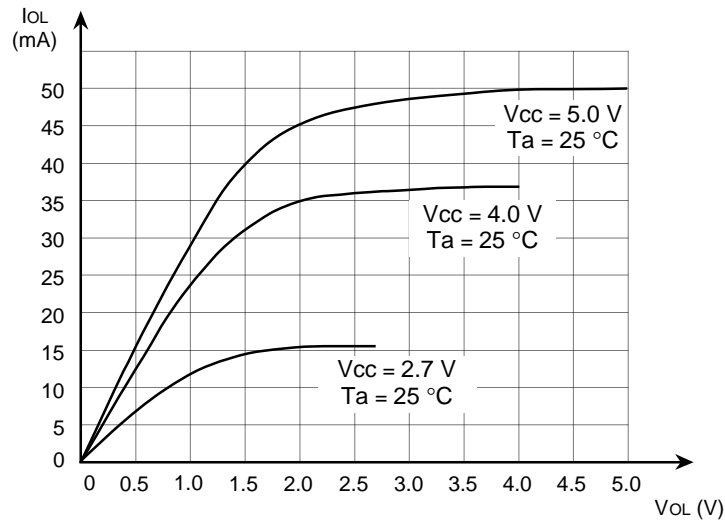

Fig. 3.2.6 Standard characteristic example of CMOS output port at N-channel drive (2)



# APPENDIX

## 3.2 Standard characteristics

### 3.2.3 A-D conversion standard characteristics

Figure 3.2.7 shows the A-D conversion standard characteristics.

The lower-side line on the graph indicates the absolute precision error. It represents the deviation from the ideal value. For example, the conversion of output code from 0 to 1 occurs ideally at the point of  $AN_0 = 10 \text{ mV}$ , but the measured value is  $0 \text{ mV}$ . Accordingly, the measured point of conversion is represented as " $10 - 0 = 10 \text{ mV}$ ."

The upper-side line on the graph indicates the width of input voltages equivalent to output codes. For example, the measured width of the input voltage for output code 13 is  $22 \text{ mV}$ , so the differential nonlinear error is represented as " $22 - 20 = 2 \text{ mV}$ " (0.1 LSB).

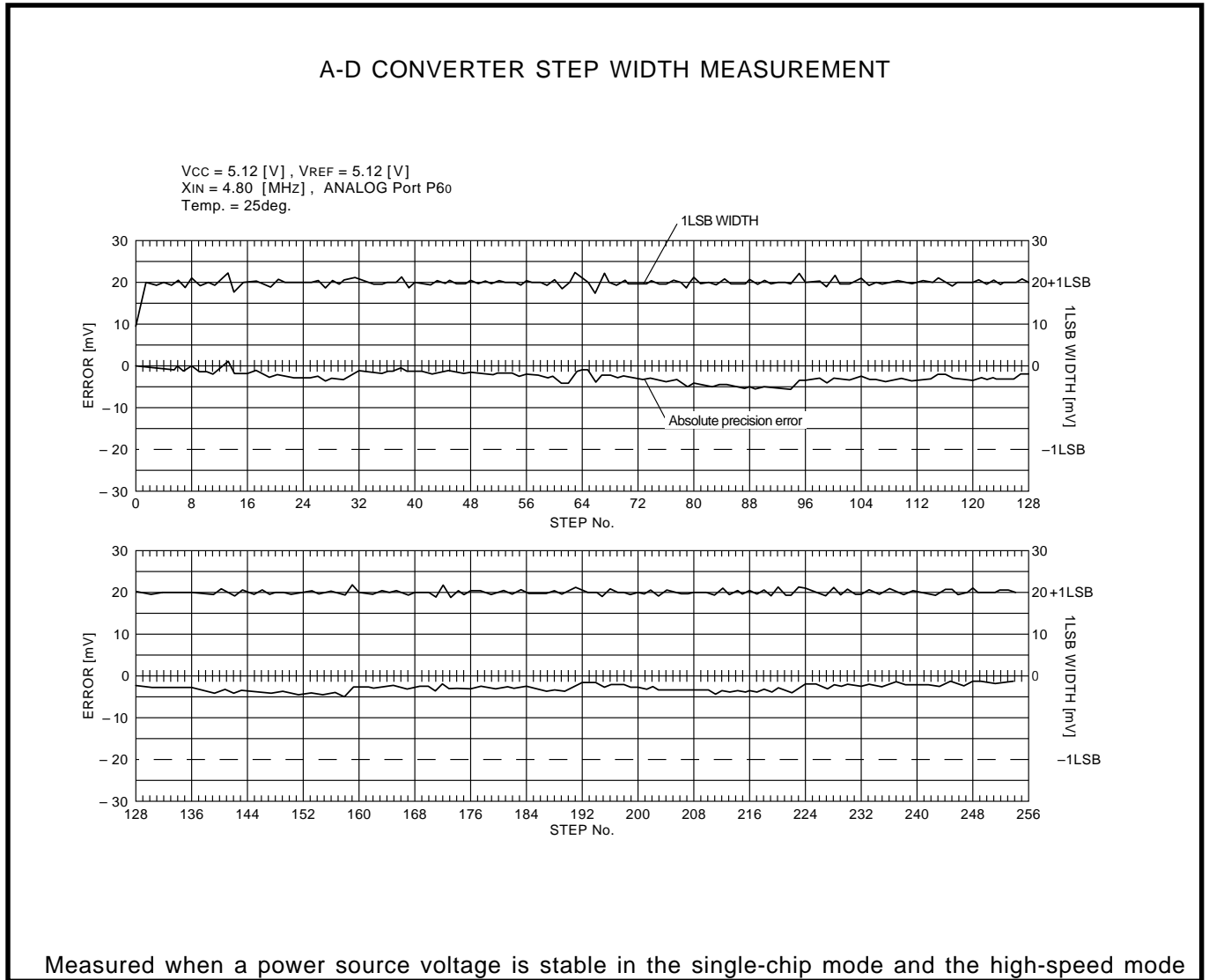

Measured when a power source voltage is stable in the single-chip mode and the high-speed mode

**Fig. 3.2.7 A-D conversion standard characteristics**

### 3.2.4 D-A conversion standard characteristics

Figure 3.2.8 shows the D-A conversion standard characteristics. The lower-side line on the graph indicates the absolute precision error. In this case, it represents the difference between the ideal analog output value for an input code and the measured value.

The upper-side line on the graph indicates the change width of output analog value to a one-bit change of input code.

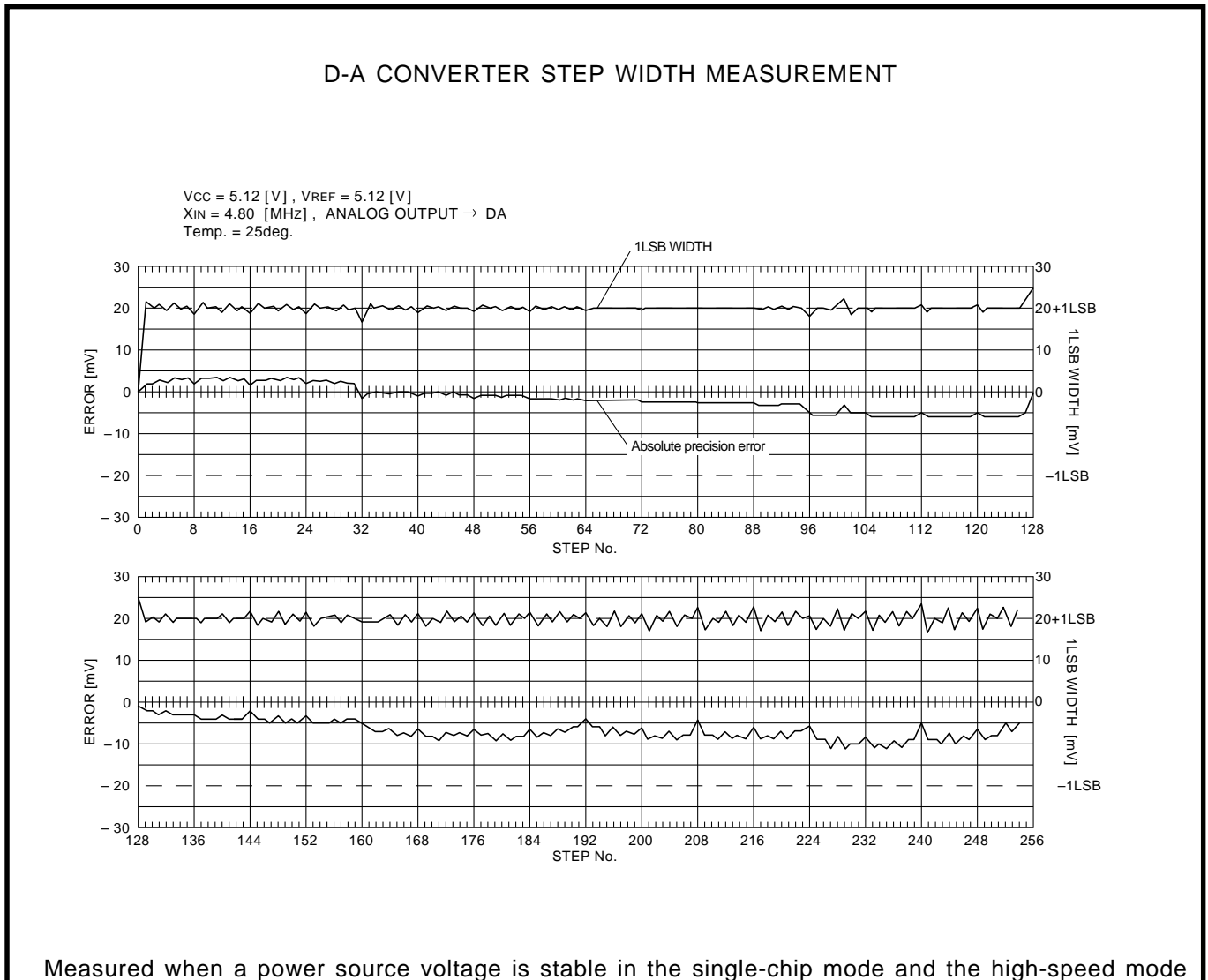

**Fig. 3.2.8 D-A conversion standard characteristics**

# APPENDIX

## 3.3 Notes on use

### 3.3 Notes on use

#### 3.3.1 Notes on interrupts

##### (1) Sequence for switching an external interrupt detection edge

When the external interrupt detection edge must be switched, make sure the following sequence.

##### Reason

The interrupt circuit recognizes the switching of the detection edge as the change of external input signals. This may cause an unnecessary interrupt.

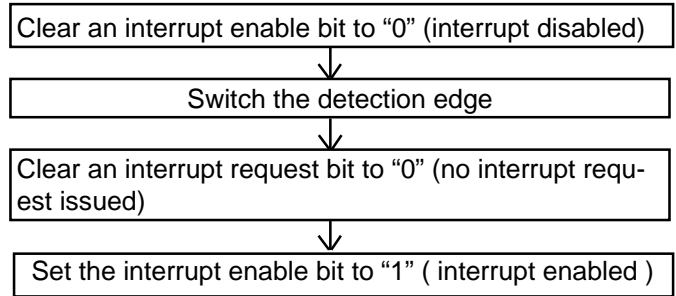

##### (2) Bit 7 of the interrupt control register 2

Fix the bit 7 of the interrupt control register 2 (Address:003F<sub>16</sub>) to "0".

Figure 3.3.1 shows the structure of the interrupt control register 2.

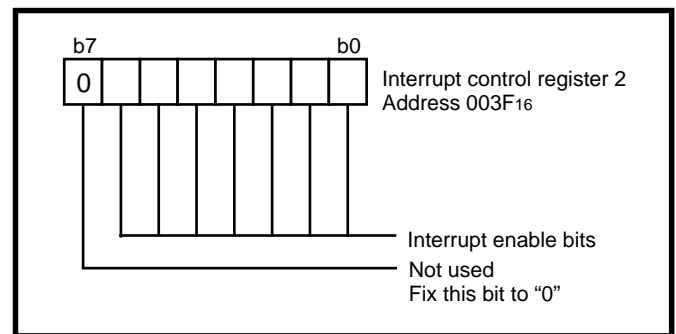

Fig. 3.3.1 Structure of interrupt control register 2

#### 3.3.2 Notes on the serial I/O1

##### (1) Stop of data transmission

As for the serial I/O1 that can be used as either a clock synchronous or an asynchronous (UART) serial I/O, clear the transmit enable bit to "0" (transmit disabled), and clear the serial I/O enable bit to "0" (serial I/O1 disabled) in the following cases :

- when stopping data transmission during transmitting data in the clock synchronous serial I/O mode
- when stopping data transmission during transmitting data in the UART mode
- when stopping only data transmission during transmitting and receiving data in the UART mode

##### Reason

Since transmission is not stopped and the transmission circuit is not initialized even if the serial I/O1 enable bit is cleared to "0" (serial I/O1 disabled), the internal transmission is running (in this case, since pins TxD, RxD, SCLK1, and SRDY1 function as I/O ports, the transmission data is not output). When data is written to the transmit buffer register in this state, the data is transferred to the transmit shift register and start to be shifted. When the serial I/O1 enable bit is set to "1" at this time, the data during internally shifting is output to the TxD pin and it may cause an operation failure to a microcomputer.

##### (2) Stop of data reception

As for the serial I/O1 that can be used as either a clock synchronous or an asynchronous (UART) serial I/O, clear the receive enable bit to "0" (receive disabled), or clear the serial I/O enable bit to "0" (serial I/O disabled) in the following case :

- when stopping data reception during receiving data in the clock synchronous serial I/O mode

Clear the receive enable bit to "0" (receive disabled) in the following cases :

- when stopping data reception during receiving data in the UART mode
- when stopping only data reception during transmitting and receiving data in the UART mode

### (3) Stop of data transmission and reception in a clock synchronous serial I/O mode

As for the serial I/O1 that can be used as either a clock synchronous or an asynchronous (UART) serial I/O, clear both the transmit enable bit and receive enable bit to "0" (transmit and receive disabled) at the same time in the following case:

- when stopping data transmission and reception during transmitting and receiving data in the clock synchronous mode (when data is transmitted and received in the clock synchronous serial I/O mode, any one of data transmission and reception cannot be stopped.)

#### Reason

In the clock synchronous serial I/O mode, the same clock is used for transmission and reception. If any one of transmission and reception is disabled, a bit error occurs because transmission and reception cannot be synchronized.

In this mode, the clock circuit of the transmission circuit also operates for data reception. Accordingly, the transmission circuit does not stop by clearing only the transmit enable bit to "0" (transmit disabled). Also, the transmission circuit is not initialized by clearing the serial I/O1 enable bit to "0" (serial I/O1 disabled) (refer to (1)).

### (4) The $\overline{\text{SRDY}}$ pin on a receiving side

When signals are output from the  $\overline{\text{SRDY}}$  pin on the reception side by using an external clock in the clock synchronous serial I/O mode, set all of the receive enable bit, the  $\overline{\text{SRDY}}$  output enable bit, and the transmit enable bit to "1" (transmit enabled).

### (5) Stop of data reception in a clock synchronous serial I/O mode

Set the serial I/O1 control register again after the transmission and the reception circuits are reset by clearing both the transmit enable bit and the receive enable bit to "0."

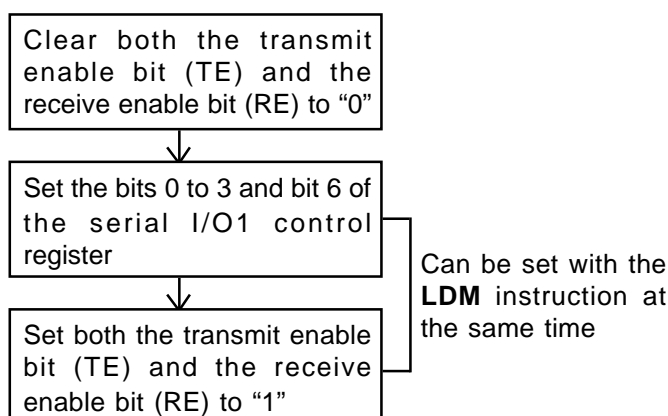

### (6) Control of data transmission using the transmit shift completion flag

The transmit shift completion flag changes from "1" to "0" with a delay of 0.5 to 1.5 shift clocks. When checking the transmit shift completion flag after writing a data to the transmit buffer register for controlling a data transmission, note this delay.

### (7) Control of data transmission using an external clock

When an external clock is used as the synchronous clock for data transmission, set the transmit enable bit to "1" at "H" level of the SCLK input signal. Also, write data to the transmit buffer register at "H" level of the SCLK input signal.

### 3.3.3 Notes on the A-D converter

#### (1) Input of signals from signal source with high impedance to an analog input pin

Make the signal source impedance for analog input low, or equip an analog input pin with an external capacitor of 0.01  $\mu\text{F}$  to 1  $\mu\text{F}$ . Further, make sure to check the operation of application products on the user side.

#### Reason

The A-D converter builds in the capacitor for analog voltage comparison. Accordingly, when signals from signal source with high impedance are input to an analog input pin, a charge and discharge noise generates. This may cause the A-D conversion precision to be worse.

# APPENDIX

## 3.3 Notes on use

---

### (2) AVss pin

Connect a power source for the A-D converter, AVss pin to the Vss line of the analog circuit.

### (3) A clock frequency during an A-D conversion

The comparator consists of a capacity coupling, and a charge of the capacity will be lost if the clock frequency is too low. Thus, make sure the following during an A-D conversion.

- $f(X_{IN})$  is 500 kHz or more .  
(When the ONW pin is "L",  $f(X_{IN})$  is 1 MHz or more.)
- Do not execute the STP instruction and WIT instruction.

### 3.3.4 Notes on the $\overline{RESET}$ pin

When a rising time of the reset signal is long, connect a ceramic capacitor or others across the  $\overline{RESET}$  pin and the Vss pin. And use a 1000 pF or more capacitor for high frequency use. When connecting the capacitor, make sure the following :

- Make the length of the wiring which is connected to a capacitor the shortest possible.
- Make sure to check the operation of application products on the user side.

#### Reason

If the several nanosecond or several ten nanosecond impulse noise enters the  $\overline{RESET}$  pin, a microcomputer may malfunction.

### 3.3.5 Notes on input and output pins

#### (1) Fix of a port input level in stand-by state

Fix input levels of an input and an I/O port for getting effect of low-power dissipation in stand-by state, especially for the I/O ports of the N-channel open-drain.

Pull-up (connect the port to Vcc) or pull-down (connect the port to Vss) these ports through a resistor.

When determining a resistance value, make sure the following:

- External circuit
- Variation of output levels during the ordinary operation

\* stand-by state : the stop mode by executing the **STP** instruction  
the wait mode by executing the **WIT** instruction

#### Reason

Even when setting as an output port with its direction register, in the following state :

- N-channel.....when the content of the port latch is "1"  
the transistor becomes the OFF state, which causes the ports to be the high-impedance state. Make sure that the level becomes "undefined" depending on external circuits.

Accordingly, the potential which is input to the input buffer in a microcomputer is unstable in the state that input levels of an input and an I/O port are "undefined." This may cause power source current.

#### (2) Modify of the content of I/O port latch

When the content of the port latch of an I/O port is modified with the bit managing instruction\*, the value of the unspecified bit may be changed.

#### Reason

The bit managing instruction is read-modify-write instruction for reading and writing data by a byte unit. Accordingly, when this instruction is executed on one bit of the port latch of an I/O port, the following is executed to all bits of the port latch.

- As for a bit which is set as an input port : The pin state is read in the CPU, and is written to this bit after bit managing.
- As for a bit which is set as an output port : The bit value is read in the CPU, and is written to this bit after bit managing.

Make sure the following :

- Even when a port which is set as an output port is changed for an input port, its port latch holds the output data.
- Even when a bit of a port latch which is set as an input port is not specified with a bit managing instruction, its value may be changed in case where content of the pin differs from a content of the port latch.

\* bit managing instructions : **SEB** and **CLB** instruction

### (3) The AVss pin when not using the A-D converter

When not using the A-D converter, handle a power source pin for the A-D converter, AVss pin as follows :

- AVss : Connect to the Vss pin

#### Reason

If the AVss pin is opened, the microcomputer may malfunction by effect of noise or others.

### 3.3.6 Notes on memory expansion mode and microprocessor mode

#### (1) Writing data to the port latch of port P3

In the memory expansion or the microprocessor mode, ports P30 and P31 can be used as the output port. Use the **LDM** or **STA** instruction for writing data to the port latch (address 0006<sub>16</sub>) of port P3.

When using a read-modify-write instruction (the **SEB** or the **CLB** instruction), allocate the read and the write enabled memory at address 0006<sub>16</sub>.

#### Reason

In the memory expansion or microprocessor mode, address 0006<sub>16</sub> is allocated in the external area.

Accordingly,

- Data is read from the external memory.
- Data is written to both the port latch of the port P3 and the external memory.

Accordingly, when executing a read-modify-write instruction for address 0006<sub>16</sub>, external memory data is read and modified, and the result is written in both the port latch of the port P3 and the external memory. If the read enabled memory is not allocated at address 0006<sub>16</sub>, the read data is undefined. The undefined data is modified and written to the port latch of the port P3. The port latch data of port P3 becomes "undefined."

#### (2) Overlap of an internal memory and an external memory

When the internal and the external memory are overlapped in the memory expansion mode, the internal memory is valid in this overlapped area. When the CPU writes or reads to this area, the following is performed :

- When reading data  
Only the data in the internal memory is read into the CPU and the data in the external memory is not read into the CPU. However, as the read signal and address are still valid, the external memory data of the corresponding address is output to the external data bus.
- When writing data  
Data is written in both the internal and the external memory.

# APPENDIX

## 3.3 Notes on use

### 3.3.7 Notes on built-in PROM

#### (1) Programming adapter

To write or read data into/from the internal PROM, use the dedicated programming adapter and general-purpose PROM programmer as shown in Table 3.3.1.

**Table 3.3.1 Programming adapter**

Microcomputer	Programming adapter	PROM mode
M38063E6FS	PCA4738L-80A	256K
M38063E6FP (one-time blank)	PCA4738F-80A	
M38063E6GP (one-time blank)	PCA4738G-80A	
M38067ECAF5	PCA4738L-80A	1M
M38067E6FP (one-time blank)	PCA4738F-80A	
M38067E6DFP (one-time blank)		
M38067E6AFP (one-time blank)		
M38067E6GP (one-time blank)	PCA4738G-80A	
M38067E6AGP (one-time blank)		

#### (2) Write and read

In PROM mode, operation is the same as that of the M5M27C256AK and the M5M27C101, but programming conditions of PROM programmer are not set automatically because there are no internal device ID codes. Accurately set the following conditions for data write/read. Take care not to apply 21 V to Vpp pin (is also used as the CNVSS pin), or the product may be permanently damaged.

- Programming voltage : 12.5 V
- Setting of programming adapter switch : refer to table 3.3.2
- Setting of PROM programmer address : refer to table 3.3.3

**Table 3.3.2 Setting of programming adapter switch**

Programming adapter	SW 1	SW 2	SW 3
PCA4738F-80A	CMOS	CMOS	OFF
PCA4738L-80A			
PCA4738G-80A			

**Table 3.3.3 Setting of PROM programmer address**

Microcomputer	PROM programmer start address	PROM programmer completion address
M38063E6FS	Address : 2080 <sub>16</sub> (Note 1)	Address : 7FFD <sub>16</sub> (Note 1)
M38063E6FP		
M38063E6GP		
M38067E6FP	Address : 4080 <sub>16</sub> (Note 2)	Address : FFFD <sub>16</sub> (Note 2)
M38067E6GP		
M38067E6DFP		
M38067E6AFS		
M38067E6AFP		
M38067E6AGP		

Note1 : Addresses A080<sub>16</sub> to FFFD<sub>16</sub> in the internal PROM correspond to addresses 2080<sub>16</sub> to 7FFD<sub>16</sub> in the ROM programmer.

2 : Addresses 4080<sub>16</sub> to FFFD<sub>16</sub> in the internal PROM correspond to addresses 4080<sub>16</sub> to FFFD<sub>16</sub> in the ROM programmer.

**(3) Erasing**

Contents of the windowed EPROM are erased through an ultraviolet light source of the wavelength 2537-Ångstrom . At least 15 W-sec/cm<sup>2</sup> are required to erase EPROM contents.



# APPENDIX

## 3.4 Countermeasures against noise

### 3.4 Countermeasures against noise

Countermeasures against noise are described below. The following countermeasures are effective against noise in theory, however, it is necessary not only to take measures as follows but to evaluate before actual use.

#### 3.4.1 Shortest wiring length

The wiring on a printed circuit board can be as an antenna which feeds noise into the microcomputer.

The shorter the total wiring length (by mm unit), the less the possibility of noise insertion into a microcomputer.

#### (1) Wiring for the $\overline{\text{RESET}}$ pin

Make the length of wiring which is connected to the  $\overline{\text{RESET}}$  pin as short as possible. Especially, connect a capacitor across the  $\overline{\text{RESET}}$  pin and the Vss pin with the shortest possible wiring (within 20mm).

#### Reason

The reset works to initialize a microcomputer.

The width of a pulse input into the  $\overline{\text{RESET}}$  pin is determined by the timing necessary conditions. If noise having a shorter pulse width than the standard is input to the  $\overline{\text{RESET}}$  pin, the reset is released before the internal state of the microcomputer is completely initialized. This may cause a program runaway.

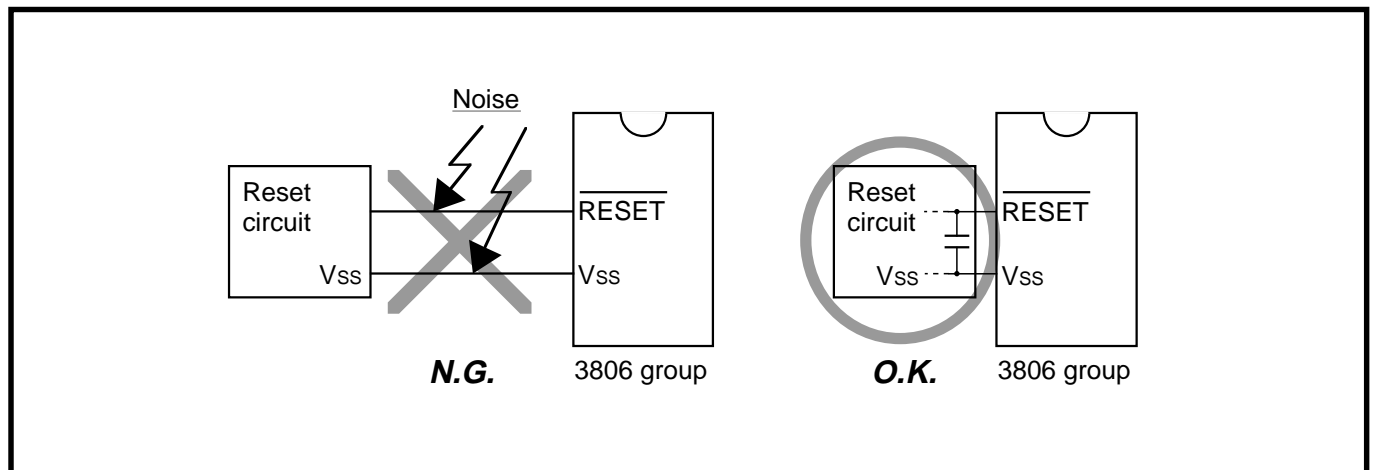

Fig. 3.4.1 Wiring for the  $\overline{\text{RESET}}$  pin

#### (2) Wiring for clock input/output pins

- Make the length of wiring which is connected to clock I/O pins as short as possible.
- Make the length of wiring (within 20mm) across the grounding lead of a capacitor which is connected to an oscillator and the Vss pin of a microcomputer as short as possible.
- Separate the Vss pattern only for oscillation from other Vss patterns.

#### Reason

A microcomputer's operation synchronizes with a clock generated by the oscillator (circuit). If noise enters clock I/O pins, clock waveforms may be deformed. This may cause a malfunction or program runaway.

Also, if a potential difference is caused by the noise between the Vss level of a microcomputer and the Vss level of an oscillator, the correct clock will not be input in the microcomputer.

## 3.4 Countermeasures against noise

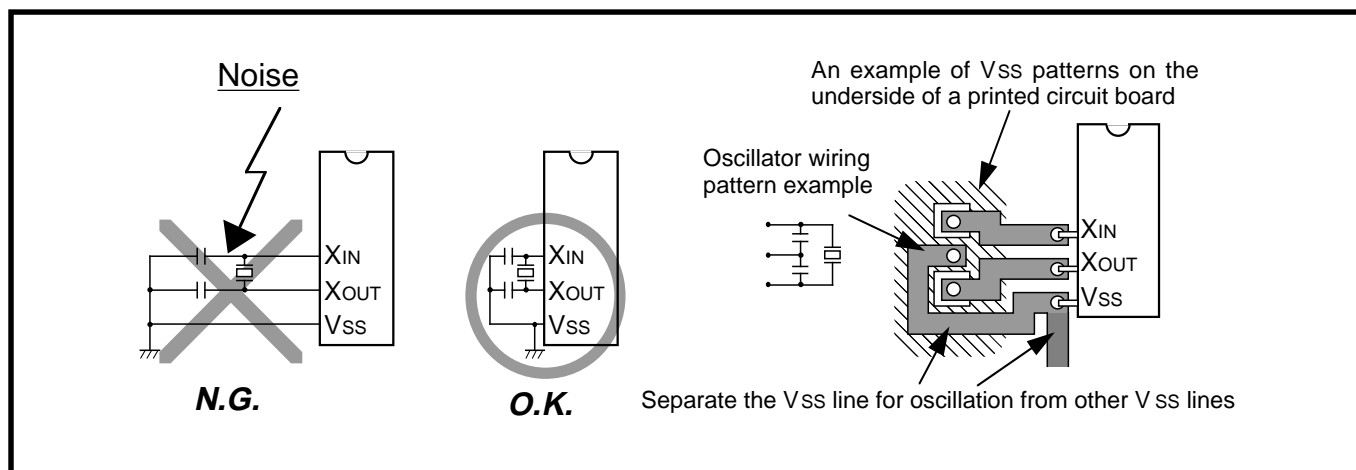

Fig. 3.4.2 Wiring for clock I/O pins

### (3) Wiring for the VPP pin of the One Time PROM version and the EPROM version

(In this microcomputer the VPP pin is also used as the CNVss pin)

Connect an approximately 5 kΩ resistor to the VPP pin the shortest possible in series and also to the VSS pin. When not connecting the resistor, make the length of wiring between the VPP pin and the VSS pin the shortest possible.

Note: Even when a circuit which included an approximately 5 kΩ resistor is used in the Mask ROM version, the microcomputer operates correctly.

#### Reason

The VPP pin of the One Time PROM and the EPROM version is the power source input pin for the built-in PROM. When programming in the built-in PROM, the impedance of the VPP pin is low to allow the electric current for wiring flow into the PROM. Because of this, noise can enter easily. If noise enters the VPP pin, abnormal instruction codes or data are read from the built-in PROM, which may cause a program runaway.

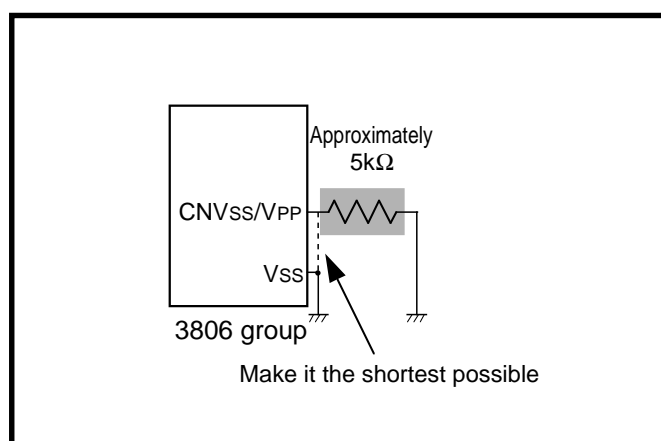

Fig. 3.4.3 Wiring for the VPP pin of the One Time PROM and the EPROM version

### 3.4.2 Connection of a bypass capacitor across the Vss line and the Vcc line

Connect an approximately 0.1 μF bypass capacitor across the VSS line and the VCC line as follows:

- Connect a bypass capacitor across the VSS pin and the VCC pin at equal length.
- Connect a bypass capacitor across the VSS pin and the VCC pin with the shortest possible wiring.
- Use lines with a larger diameter than other signal lines for VSS line and VCC line.

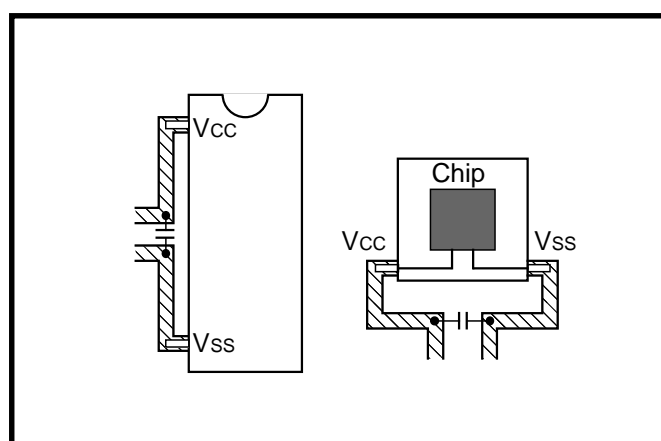

Fig. 3.4.4 Bypass capacitor across the VSS line and the VCC line

# APPENDIX

## 3.4 Countermeasures against noise

### 3.4.3 Wiring to analog input pins

- Connect an approximately 100 Ω to 1 kΩ resistor to an analog signal line which is connected to an analog input pin in series. Besides, connect the resistor to the microcomputer as close as possible.
- Connect an approximately 1000 pF capacitor across the Vss pin and the analog input pin. Besides, connect the capacitor to the Vss pin as close as possible. Also, connect the capacitor across the analog input pin and the Vss pin at equal length.

#### Reason

Signals which is input in an analog input pin (such as an A-D converter input pin) are usually output signals from sensor. The sensor which detects a change of event is installed far from the printed circuit board with a microcomputer, the wiring to an analog input pin is longer necessarily. This long wiring functions as an antenna which feeds noise into the microcomputer, which causes noise to an analog input pin.

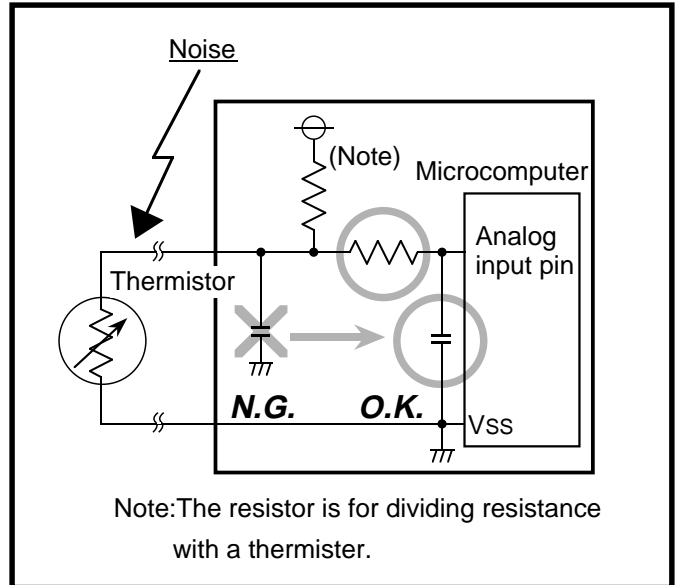

Fig.3.4.5 Analog signal line and a resistor and a capacitor

### 3.4.4. Consideration for oscillator

Take care to prevent an oscillator that generates clocks for a microcomputer operation from being affected by other signals.

#### (1) Keeping an oscillator away from large current signal lines

Install a microcomputer (and especially an oscillator) as far as possible from signal lines where a current larger than the tolerance of current value flows.

#### Reason

In the system using a microcomputer, there are signal lines for controlling motors, LEDs, and thermal heads or others. When a large current flows through those signal lines, strong noise occurs because of mutual inductance.

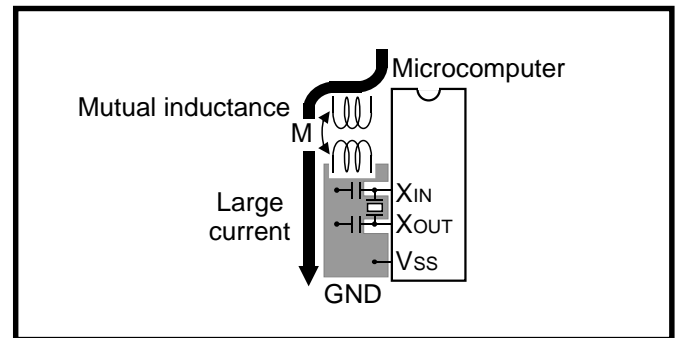

Fig.3.4.6 Wiring for a large current signal line

#### (2) Keeping an oscillator away from signal lines where potential levels change frequently

Install an oscillator and a connecting pattern of an oscillator away from signal lines where potential levels change frequently. Also, do not cross such signal lines over the clock lines or the signal lines which are sensitive to noise.

#### Reason

Signal lines where potential levels change frequently (such as the CNTR pin line) may affect other lines at signal rising or falling edge. If such lines cross over a clock line, clock waveforms may be deformed, which causes a microcomputer failure or a program runaway.

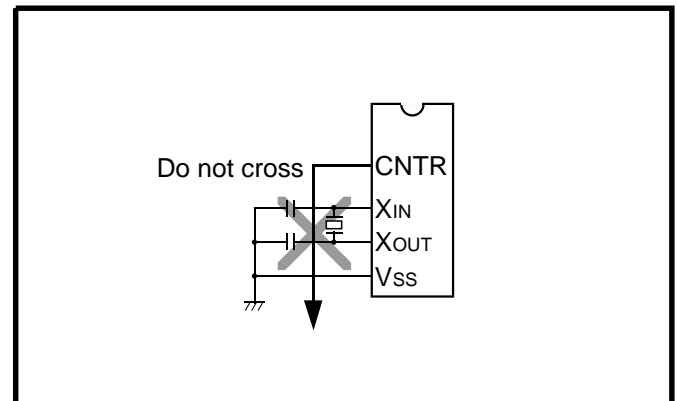

Fig.3.4.7 Wiring to a signal line where potential levels change frequently

## 3.4 Countermeasures against noise

### 3.4.5 Setup for I/O ports

Setup I/O ports using hardware and software as follows:

#### <Hardware>

- Connect a resistor of 100 Ω or more to an I/O port in series.

#### <Software>

- As for an input port, read data several times by a program for checking whether input levels are equal or not.
- As for an output port, since the output data may reverse because of noise, rewrite data to its port latch at fixed periods.
- Rewrite data to direction registers and pull-up control registers (only the product having it) at fixed periods.

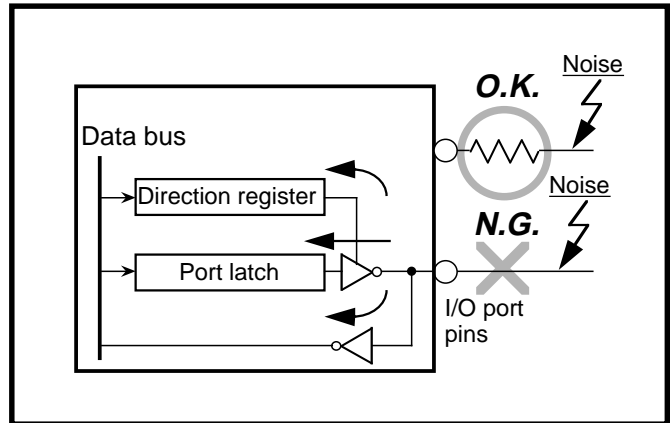

Fig. 3.4.8 Setup for I/O ports

When a direction register is set for input port again at fixed periods, a several-nanosecond short pulse may be output from this port. If this is undesirable, connect a capacitor to this port to remove the noise pulse.

### 3.4.6 Providing of watchdog timer function by software

If a microcomputer runs away because of noise or others, it can be detected by a software watchdog timer and the microcomputer can be reset to normal operation. This is equal to or more effective than program runaway detection by a hardware watchdog timer. The following shows an example of a watchdog timer provided by software.

In the following example, to reset a microcomputer to normal operation, the main routine detects errors of the interrupt processing routine and the interrupt processing routine detects errors of the main routine. This example assumes that interrupt processing is repeated multiple times in a single main routine processing.

#### <The main routine>

- Assigns a single byte of RAM to a software watchdog timer (SWDT) and writes the initial value N in the SWDT once at each execution of the main routine. The initial value N should satisfy the following condition:

$$N+1 \geq (\text{Counts of interrupt processing executed in each main routine})$$

As the main routine execution cycle may change because of an interrupt processing or others, the initial value N should have a margin.

- Watches the operation of the interrupt processing routine by comparing the SWDT contents with counts of interrupt processing count after the initial value N has been set.
- Detects that the interrupt processing routine has failed and determines to branch to the program initialization routine for recovery processing in the following cases:  
If the SWDT contents do not change after interrupt processing

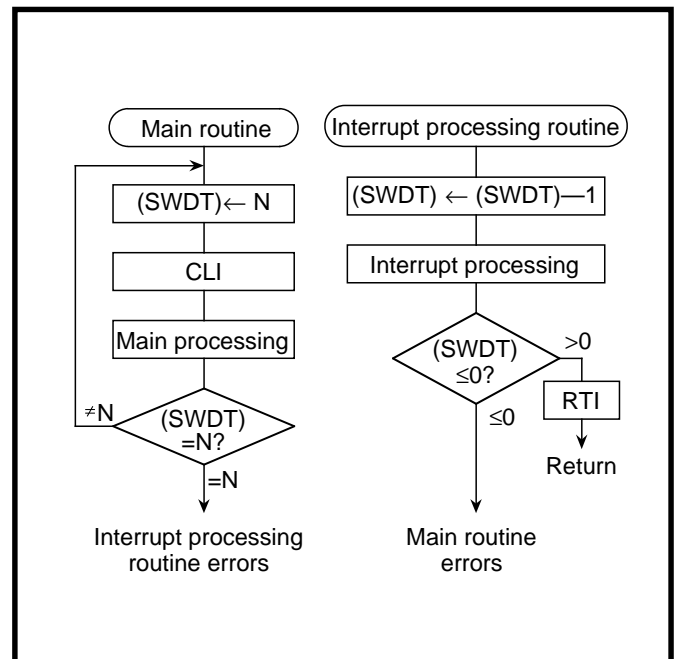

Fig. 3.4.9 Watchdog timer by software

# APPENDIX

## 3.4 Countermeasures against noise

---

<The interrupt processing routine>

- Decrements the SWDT contents by 1 at each interrupt processing.
- Determines that the main routine operates normally when the SWDT contents are reset to the initial value N at almost fixed cycles (at the fixed interrupt processing count).
- Detects that the main routine has failed and determines to branch to the program initialization routine for recovery processing in the following case:  
When the contents of the SWDT reach 0 or less by continuative decrement without initializing to the initial value N .

### 3.5 List of registers

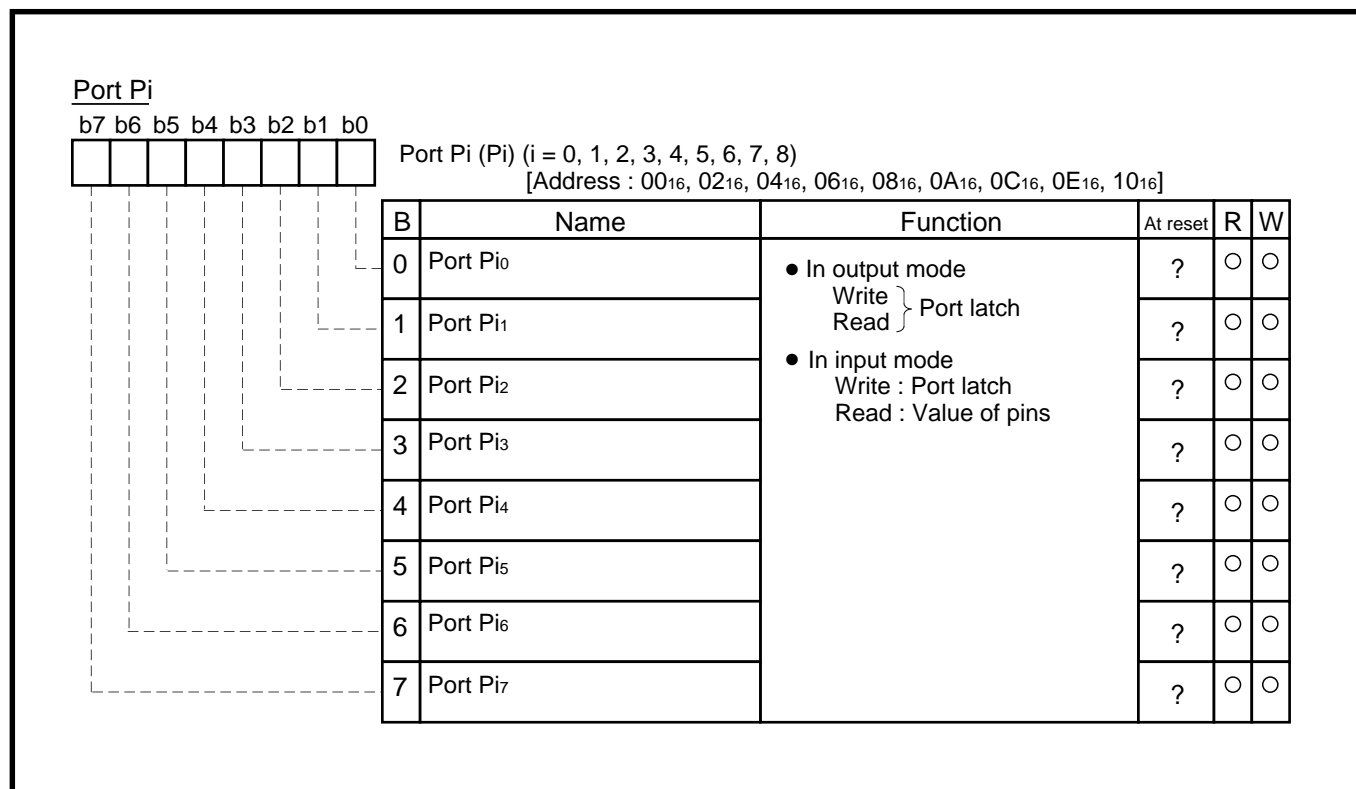

Fig. 3.5.1 Structure of Port Pi (i = 0, 1, 2, 3, 4, 5, 6, 7, 8)

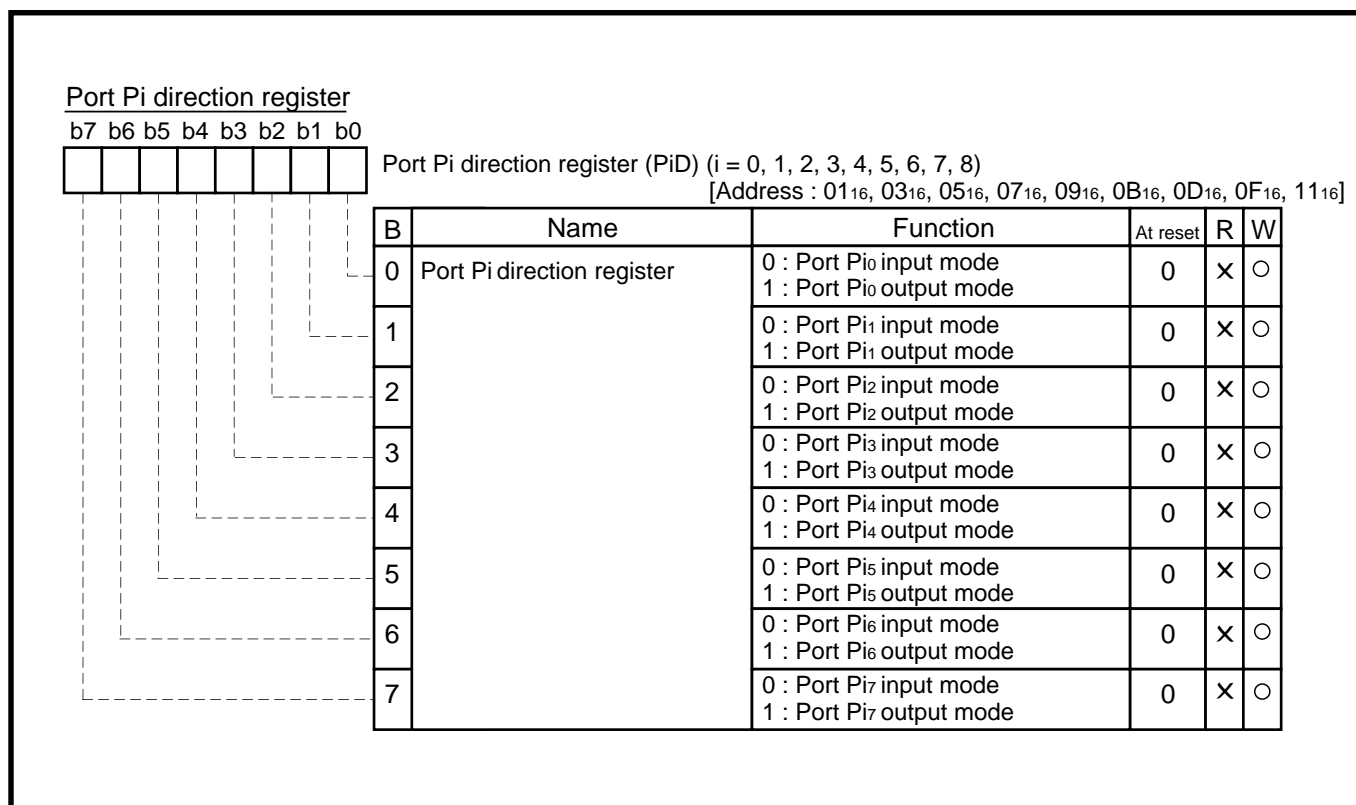

Fig. 3.5.2 Structure of Port Pi direction register (i = 0, 1, 2, 3, 4, 5, 6, 7, 8)

# APPENDIX

## 3.5 List of registers

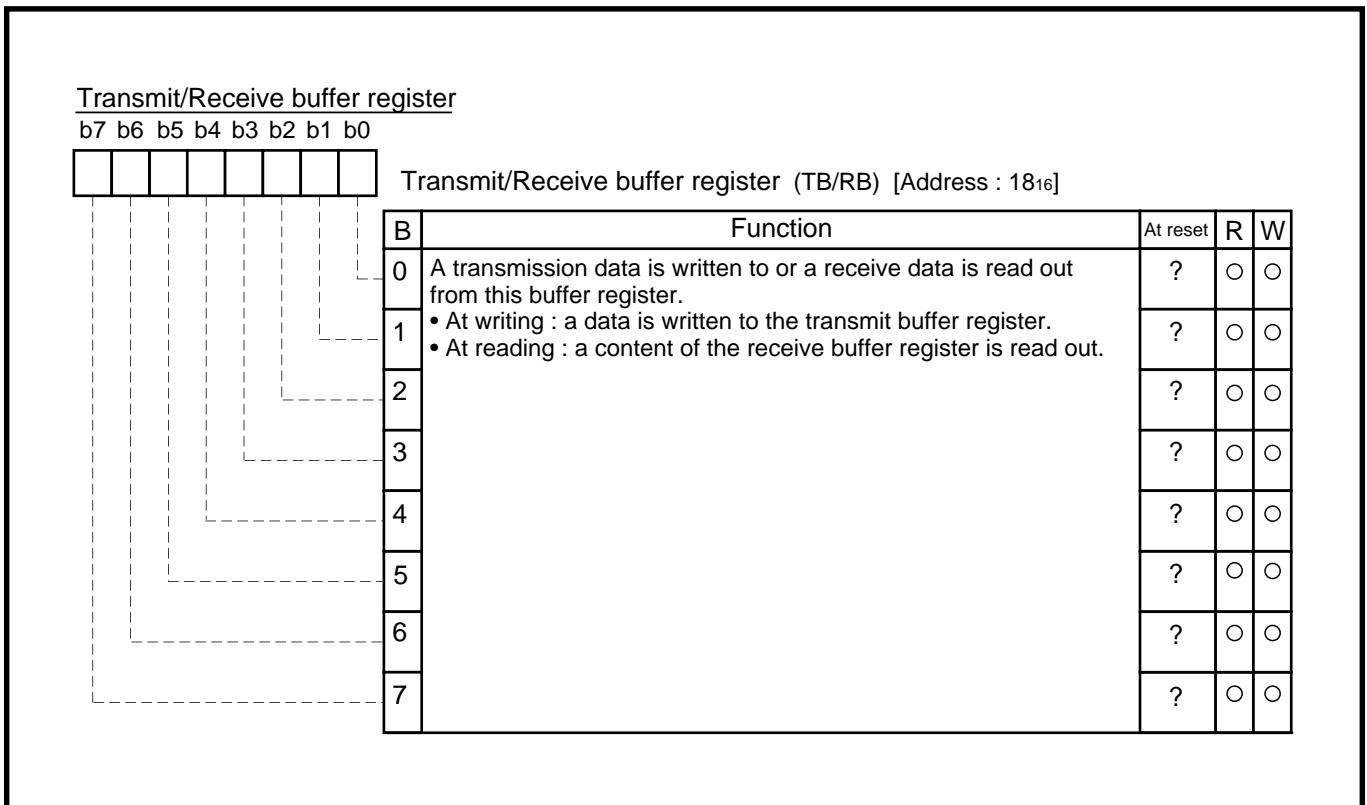

Fig. 3.5.3 Structure of Transmit/Receive buffer register

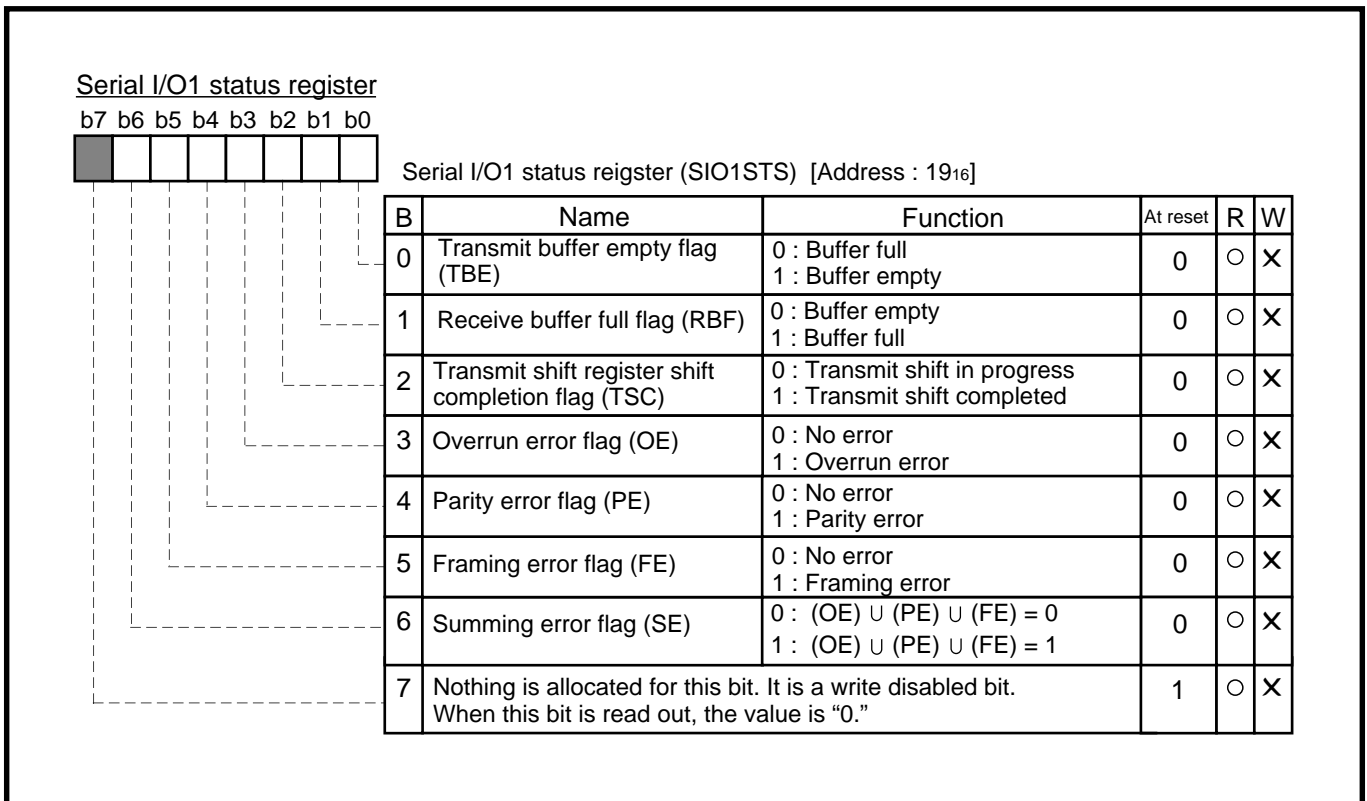

Fig. 3.5.4 Structure of Serial I/O1 status register

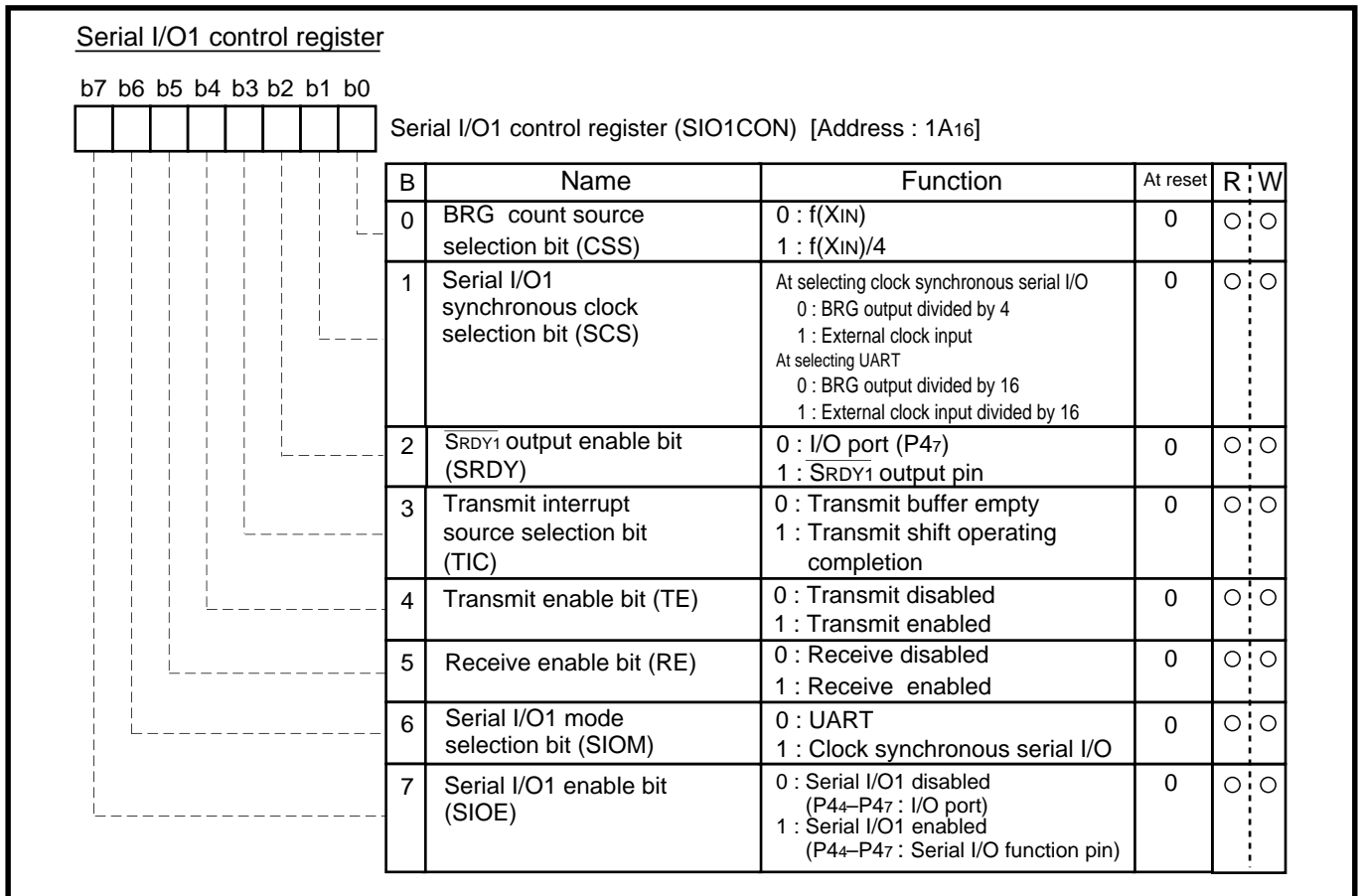

Fig. 3.5.5 Structure of Serial I/O1 control register

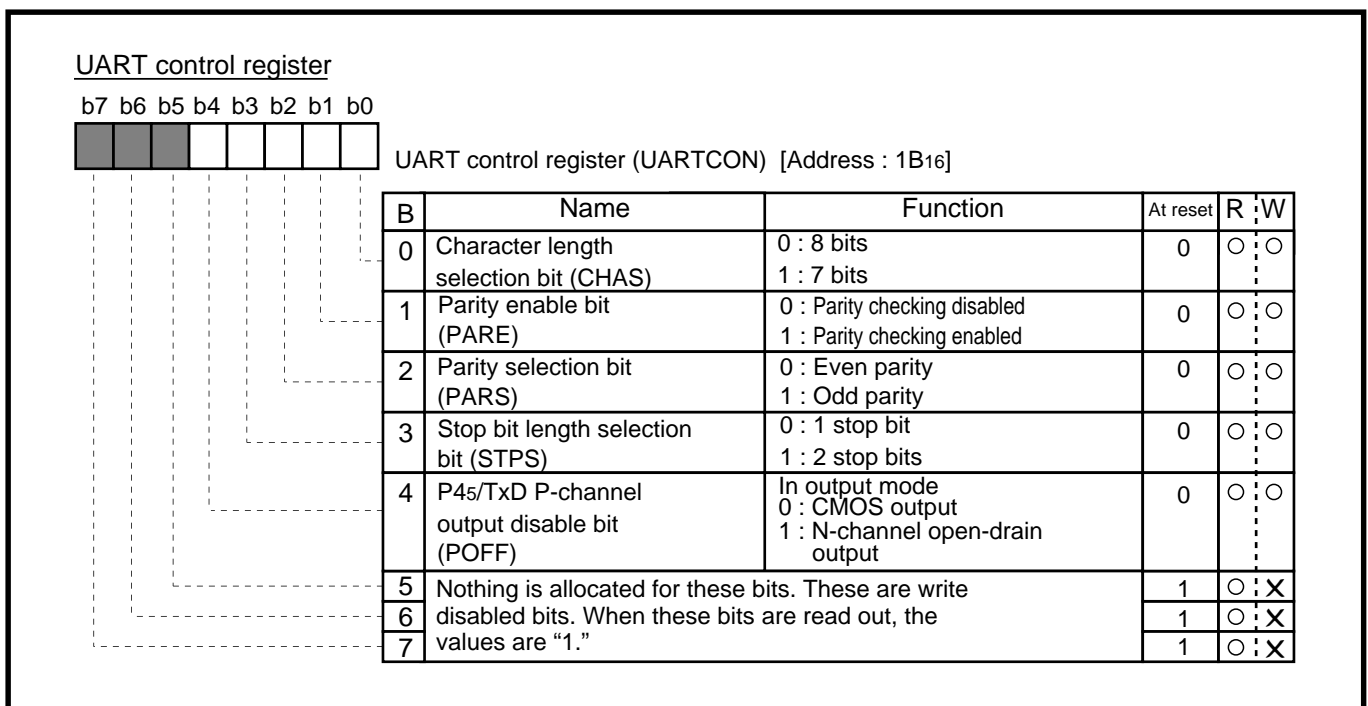

Fig. 3.5.6 Structure of UART control register



# APPENDIX

## 3.5 List of registers

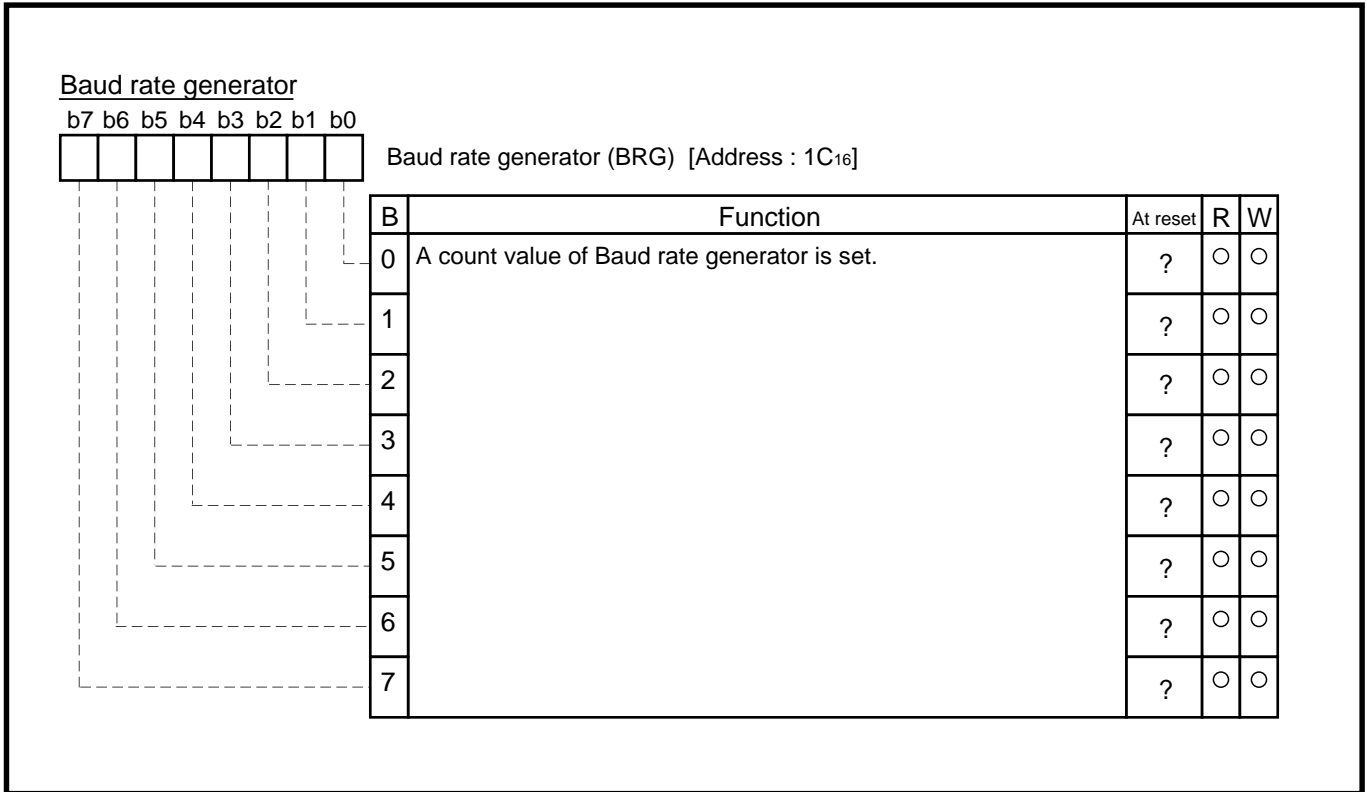

Fig. 3.5.7 Structure of Baud rate generator

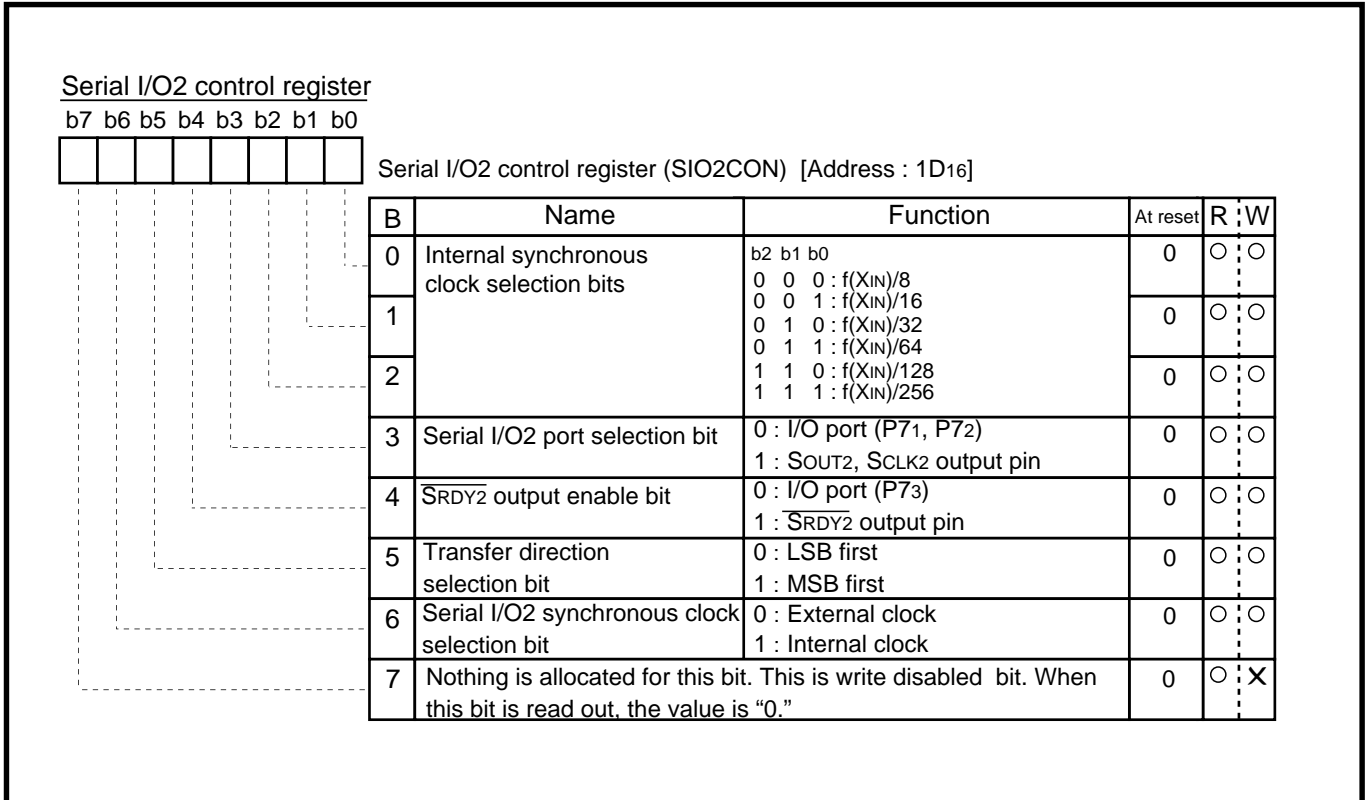

Fig. 3.5.8 Structure of Serial I/O2 control register

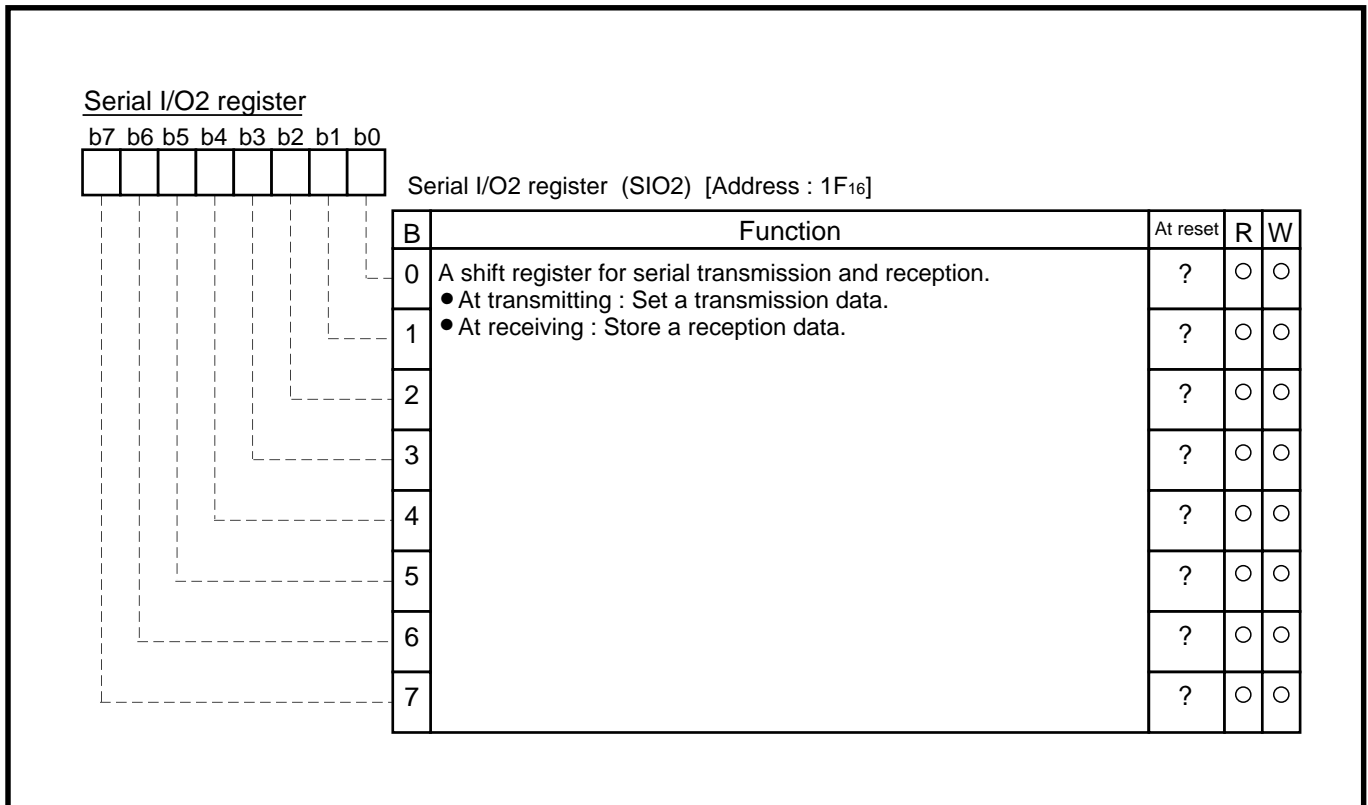

Fig. 3.5.9 Structure of Serial I/O2 register

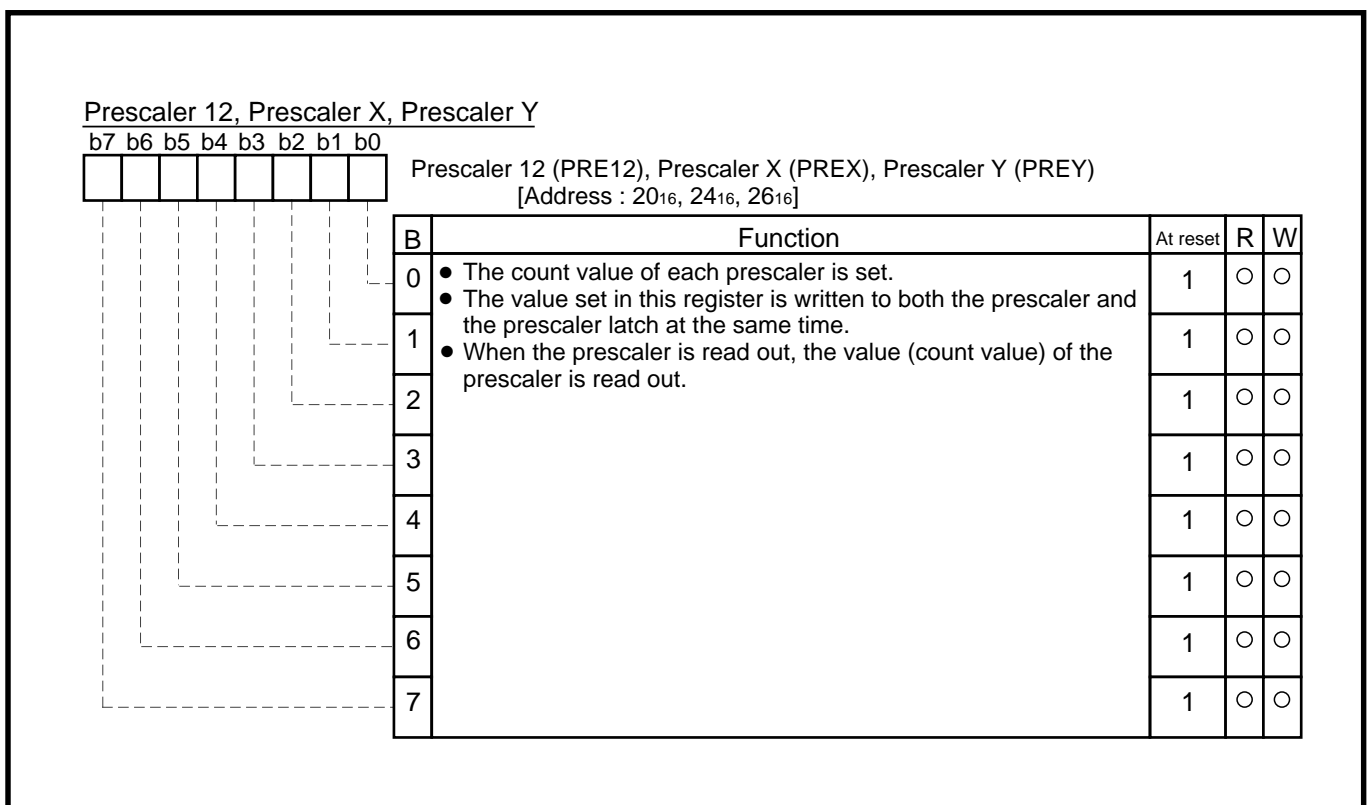

Fig. 3.5.10 Structure of Prescaler 12, Prescaler X, Prescaler Y

# APPENDIX

## 3.5 List of registers

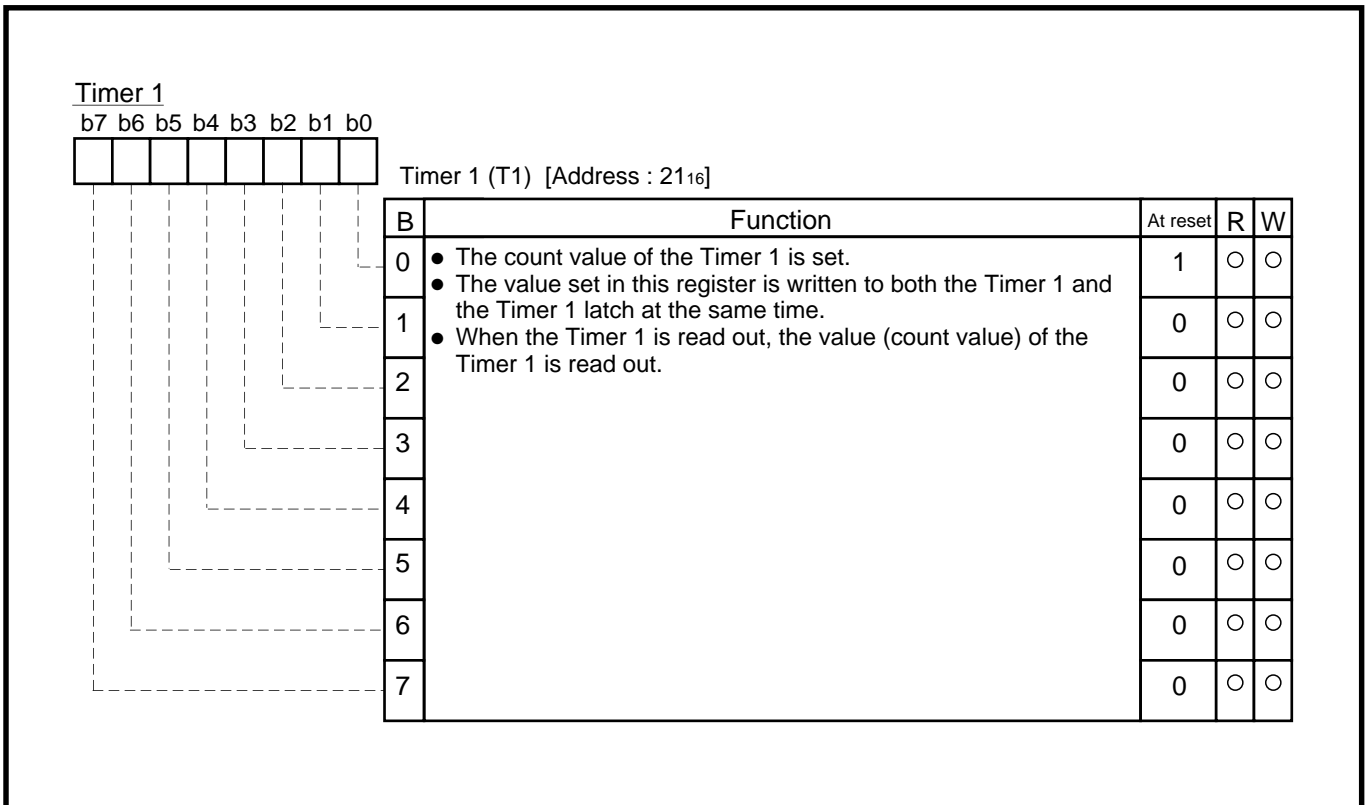

Fig. 3.5.11 Structure of Timer 1

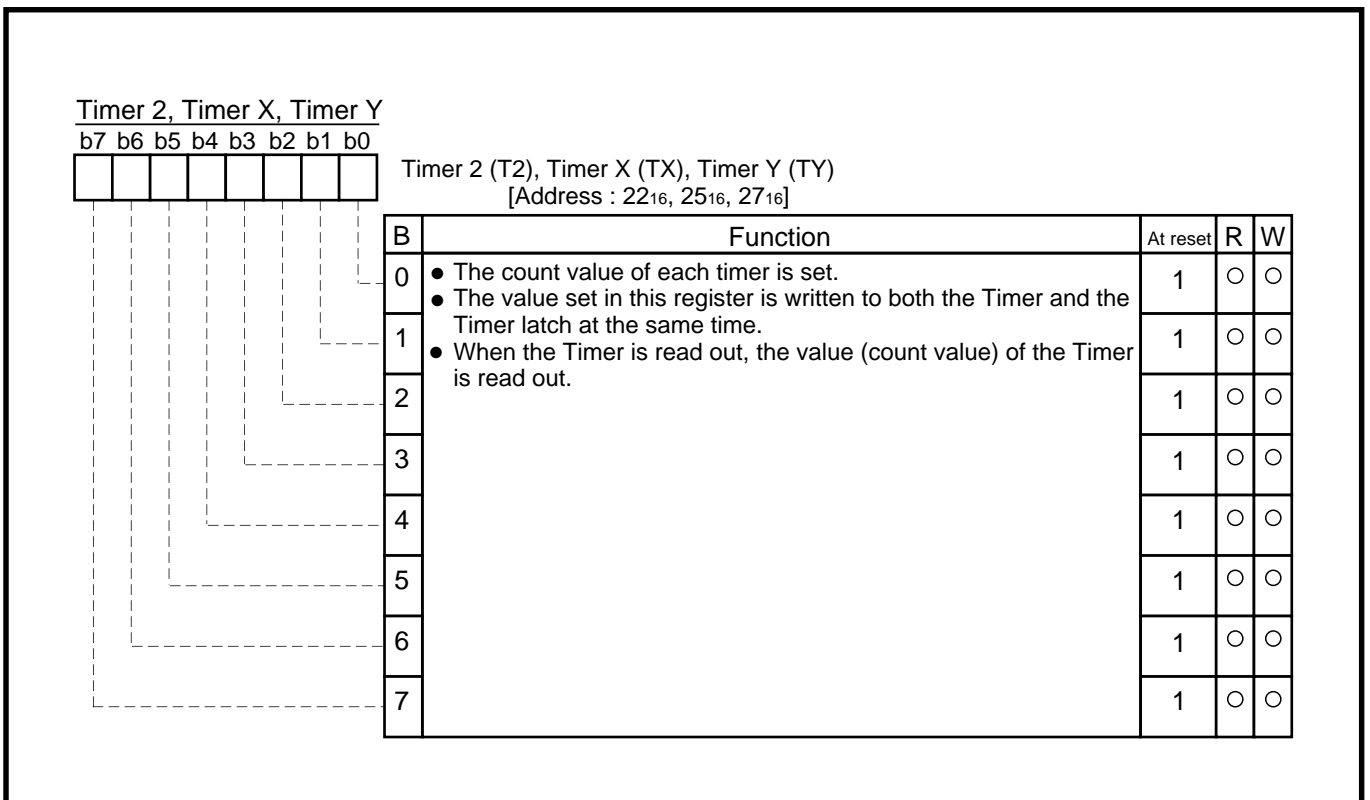

Fig. 3.5.12 Structure of Timer 2, Timer X, Timer Y

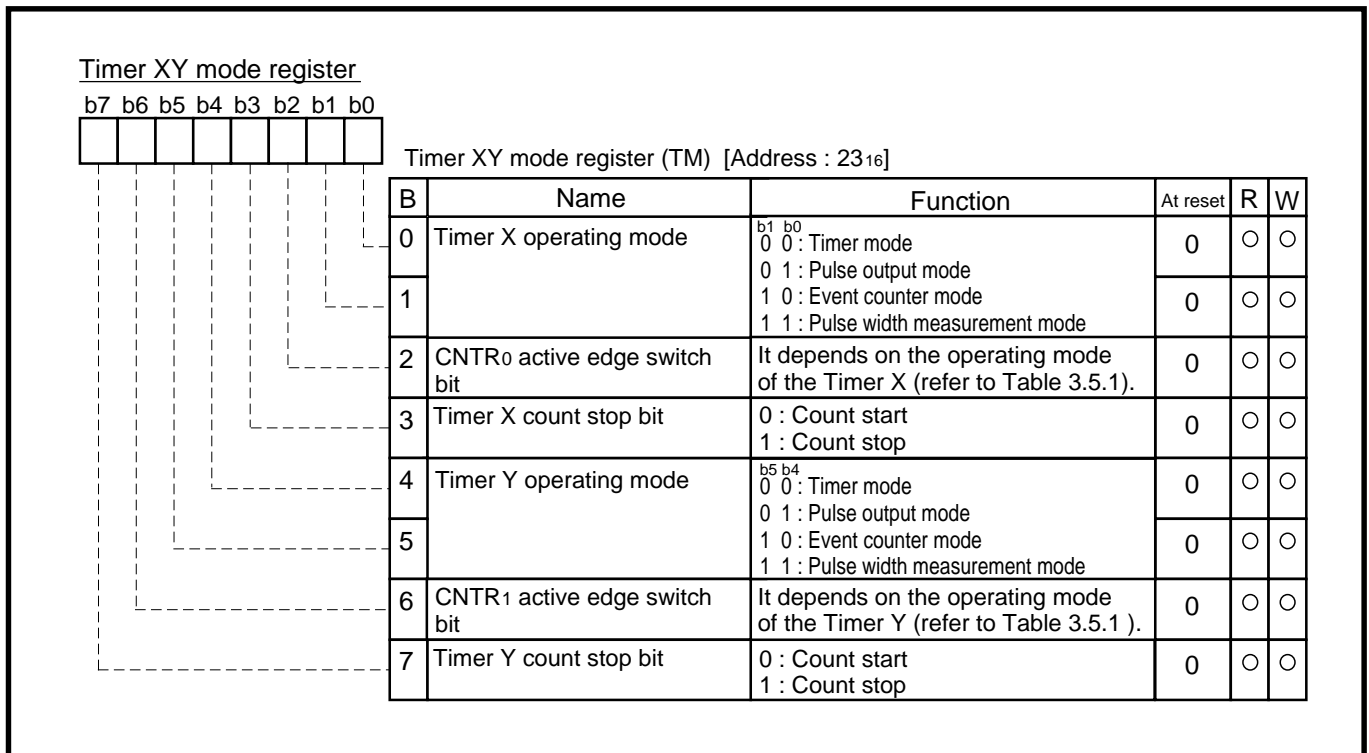

Fig. 3.5.13 Structure of Timer XY mode register

Table. 3.5.1 Function of CNTR0/CNTR1 edge switch bit

Operating mode of Timer X/Timer Y	Function of CNTR0/CNTR1 edge switch bit (bits 2 and 6)	
Timer mode	"0"	• Generation of CNTR0/CNTR1 interrupt request : Falling edge (No effect on timer count)
	"1"	• Generation of CNTR0/CNTR1 interrupt request : Rising edge (No effect on timer count)
Pulse output mode	"0"	• Start of pulse output : From "H" level • Generation of CNTR0/CNTR1 interrupt request : Falling edge
	"1"	• Start of pulse output : From "L" level • Generation of CNTR0/CNTR1 interrupt request : Rising edge
Event counter mode	"0"	• Timer X/Timer Y : Count of rising edge • Generation of CNTR0/CNTR1 interrupt request : Falling edge
	"1"	• Timer X/Timer Y : Count of falling edge • Generation of CNTR0/CNTR1 interrupt request : Rising edge
Pulse width measurement mode	"0"	• Timer X/Timer Y : Measurement of "H" level width • Generation of CNTR0/CNTR1 interrupt request : Falling edge
	"1"	• Timer X/Timer Y : Measurement of "L" level width • Generation of CNTR0/CNTR1 interrupt request : Rising edge

# APPENDIX

## 3.5 List of registers

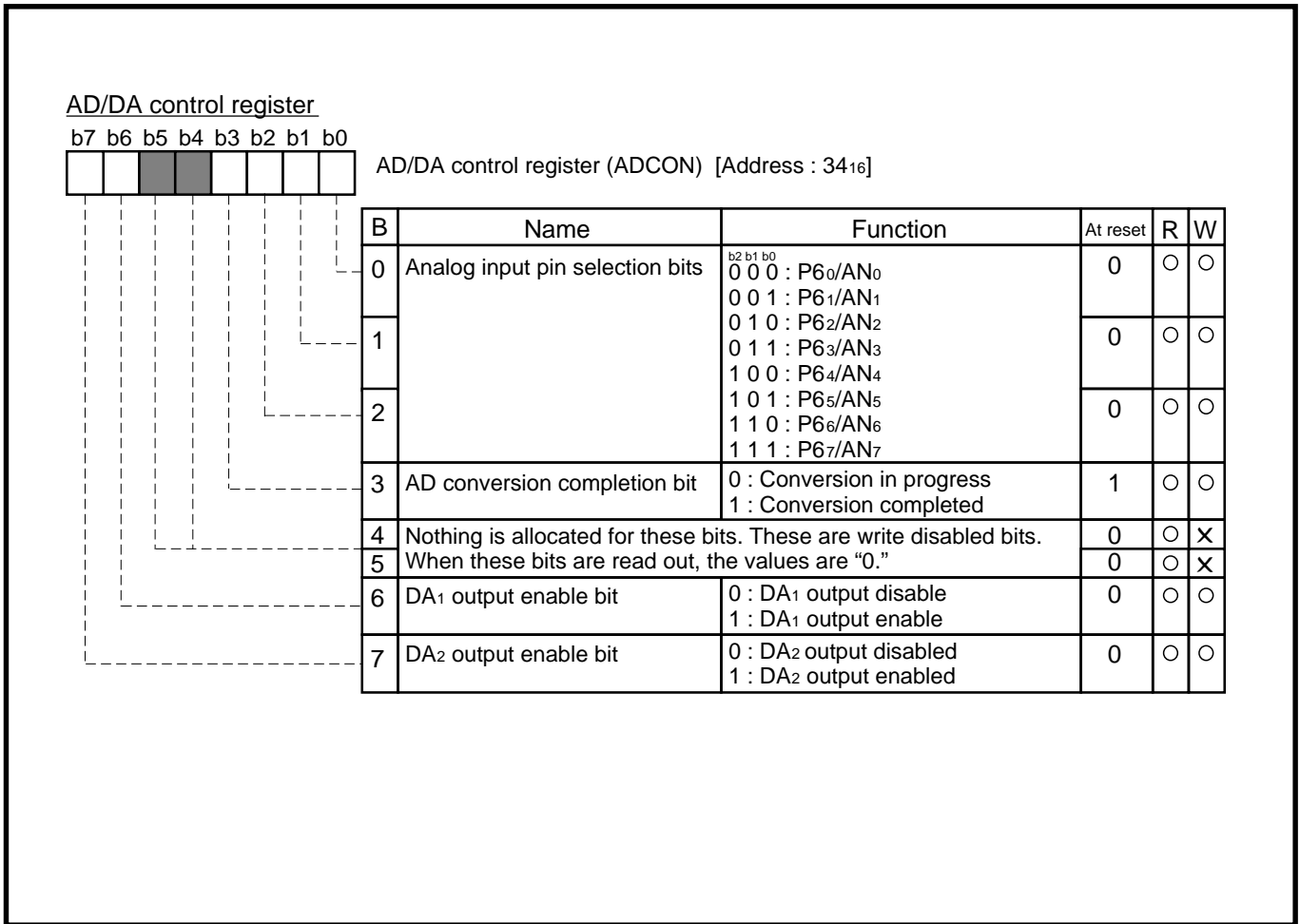

Fig. 3.5.14 Structure of AD/DA control register

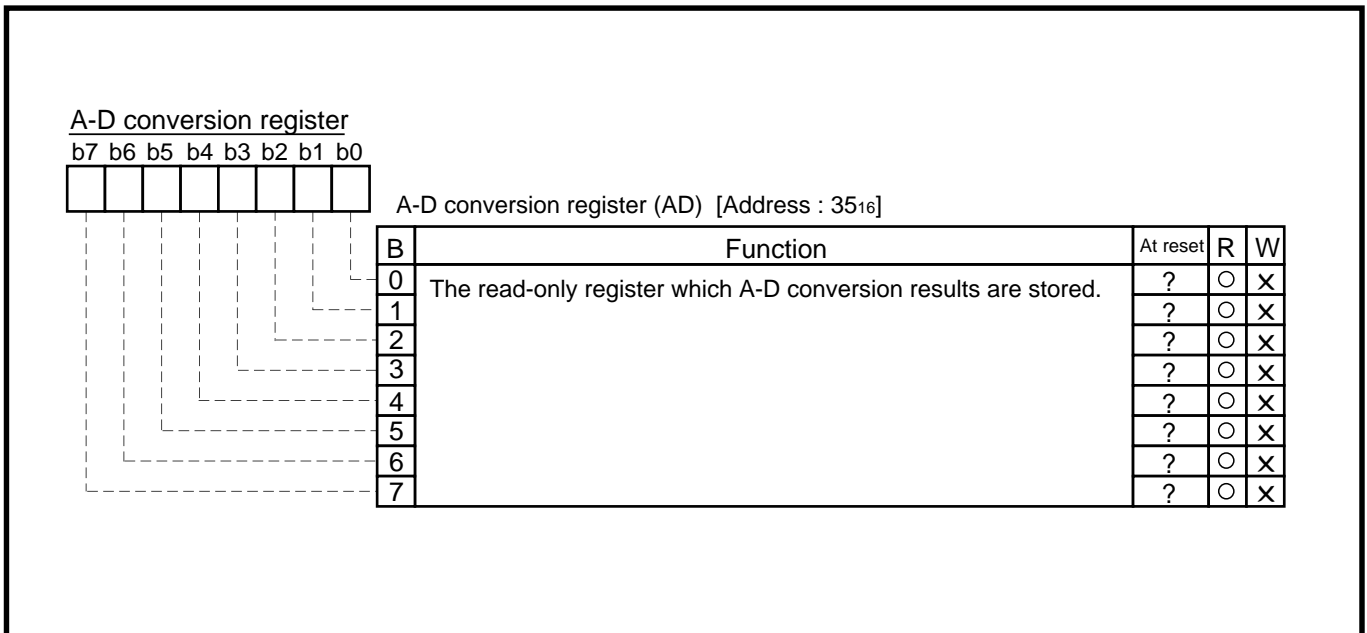

Fig. 3.5.15 Structure of A-D conversion register

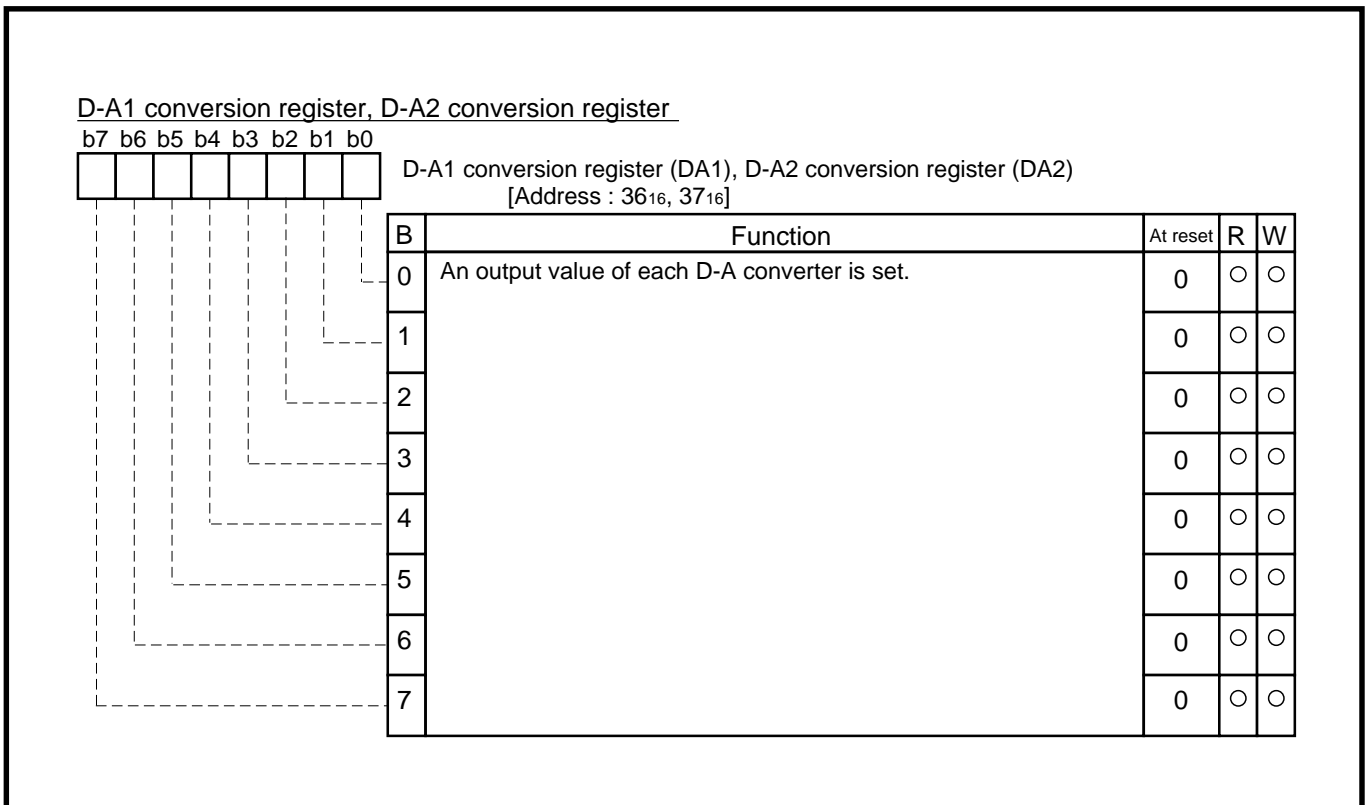

Fig. 3.5.16 Structure of D-A 1 conversion, D-A 2 conversion register

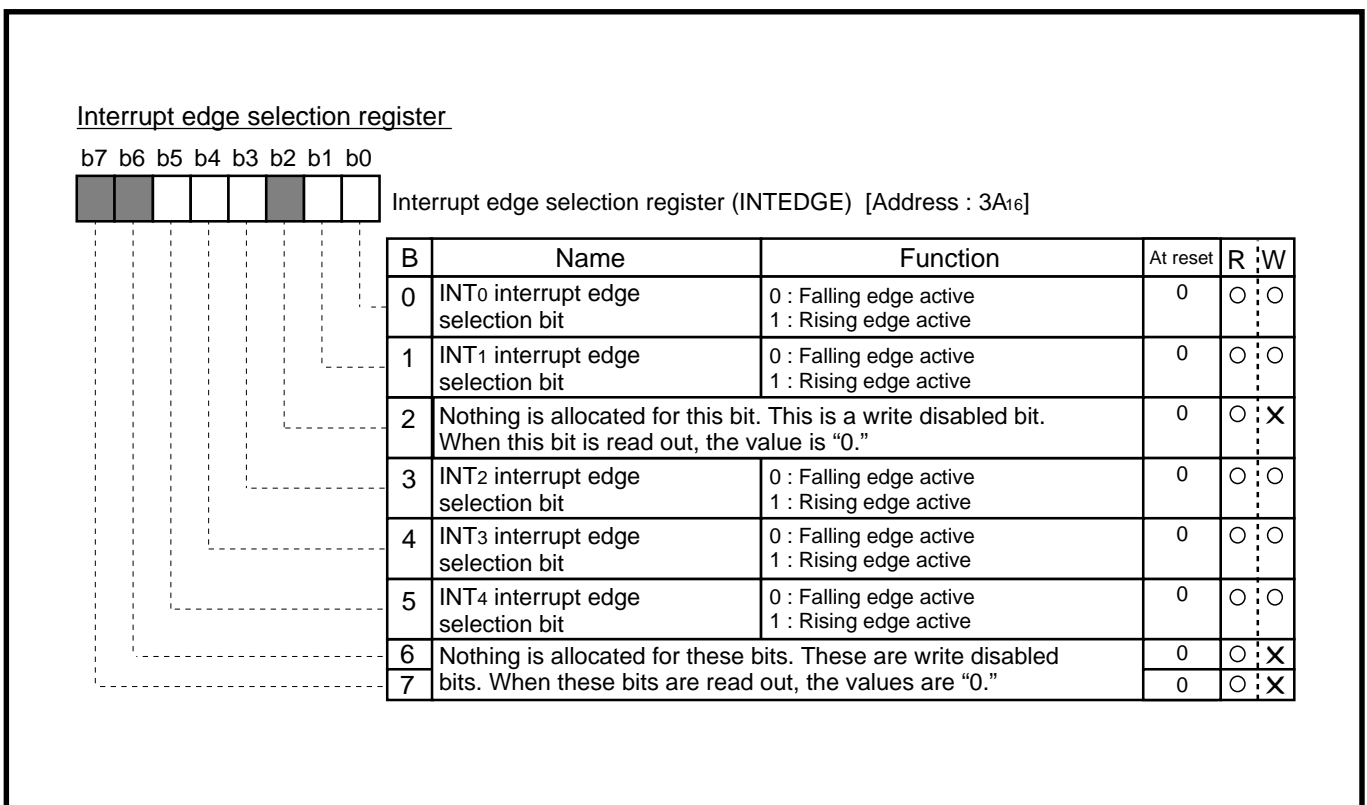

Fig. 3.5.17 Structure of Interrupt edge selection register

# APPENDIX

## 3.5 List of registers

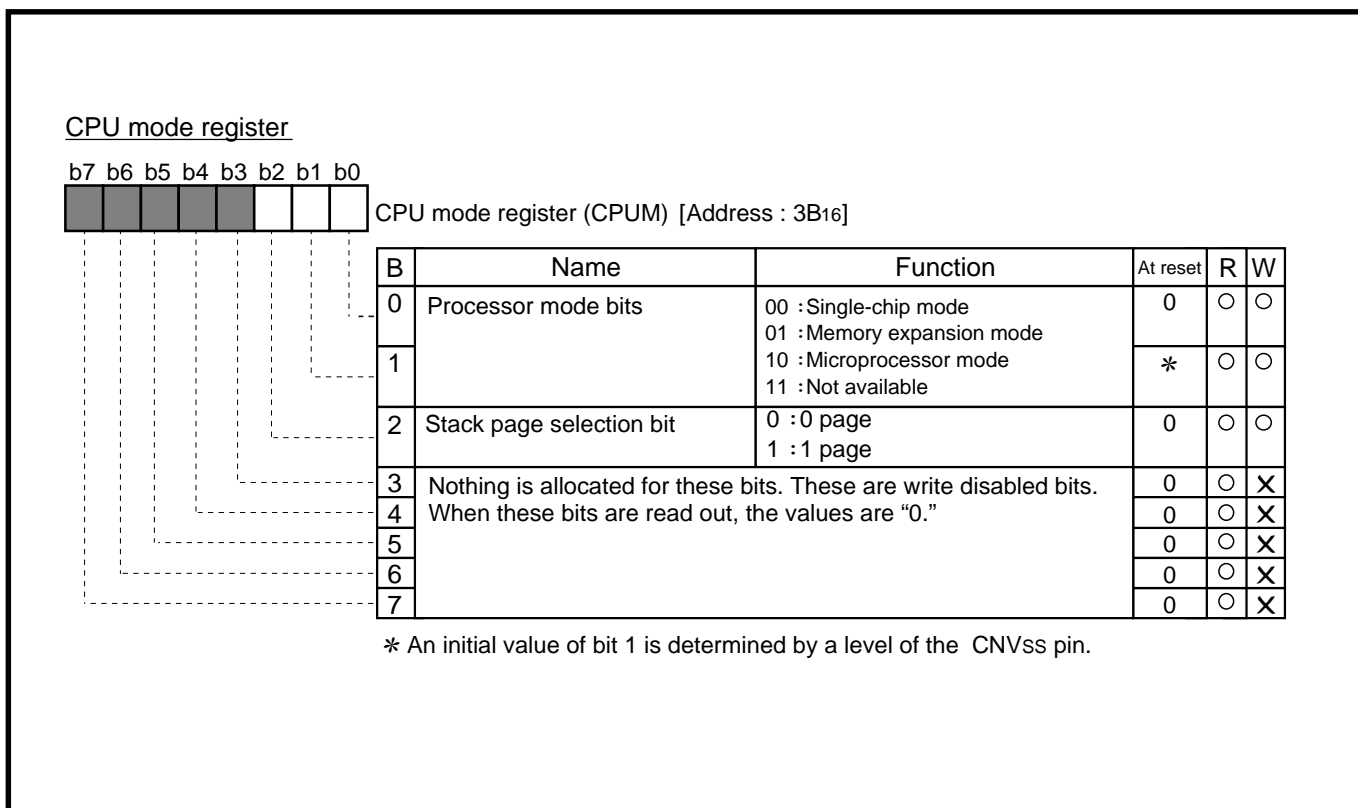

Fig. 3.5.18 Structure of CPU mode register

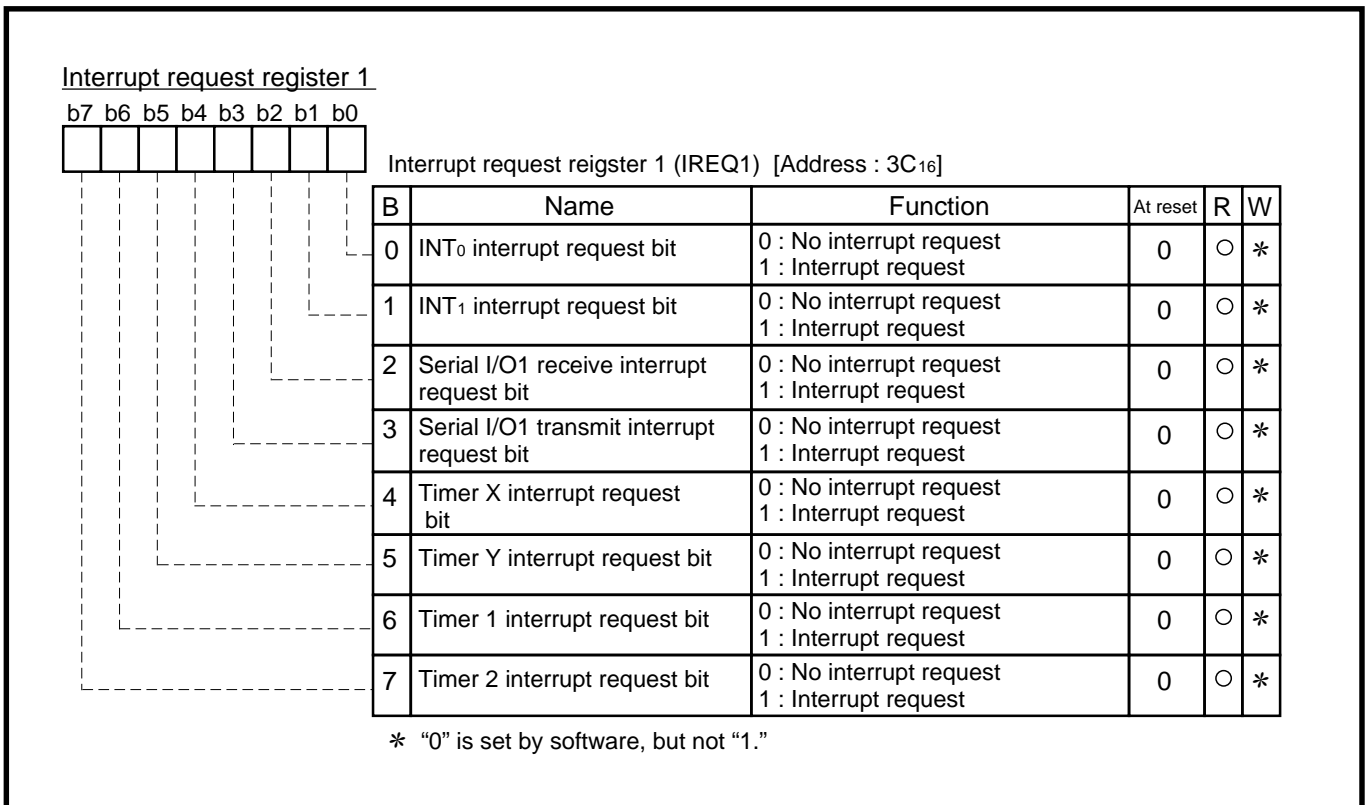

Fig. 3.5.19 Structure of Interrupt request register 1

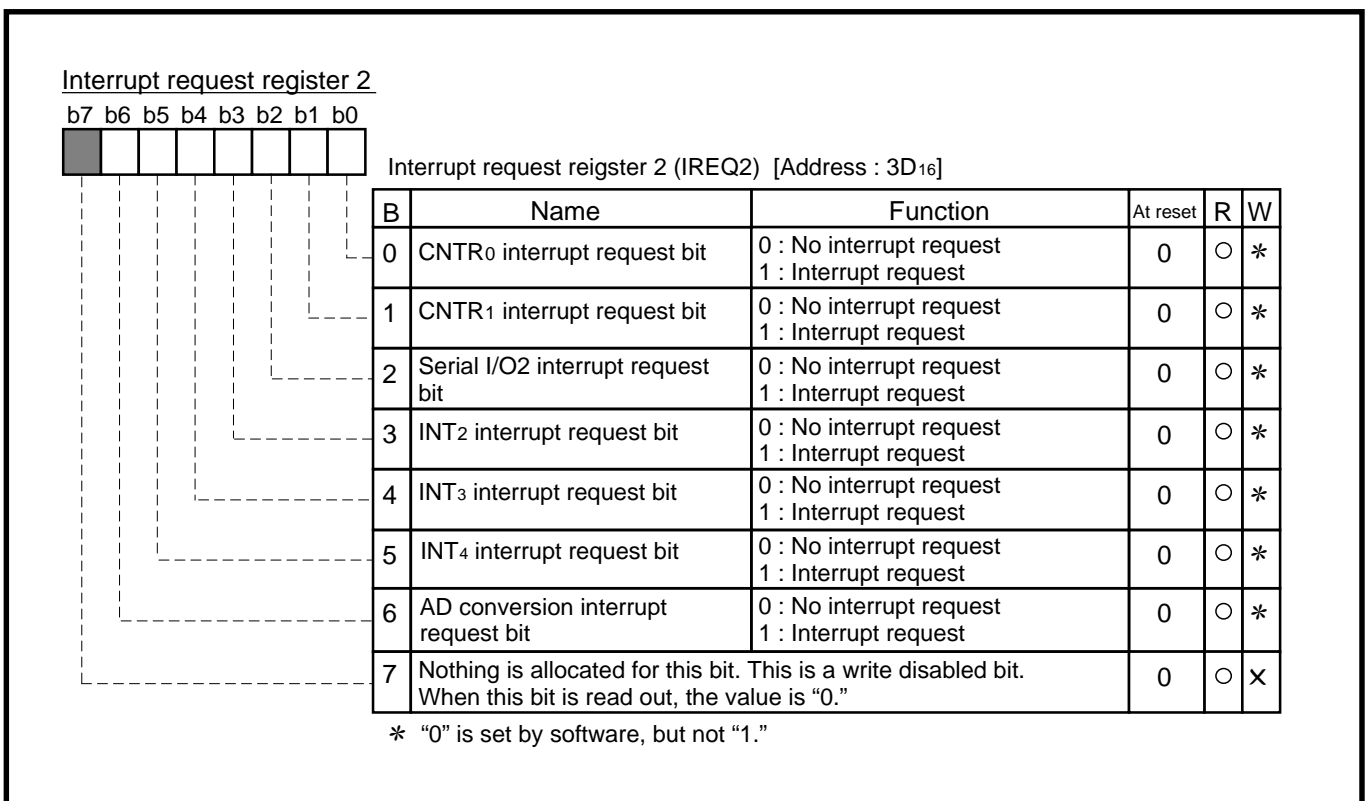

Fig. 3.5.20 Structure of Interrupt request register 2



# APPENDIX

## 3.5 List of registers

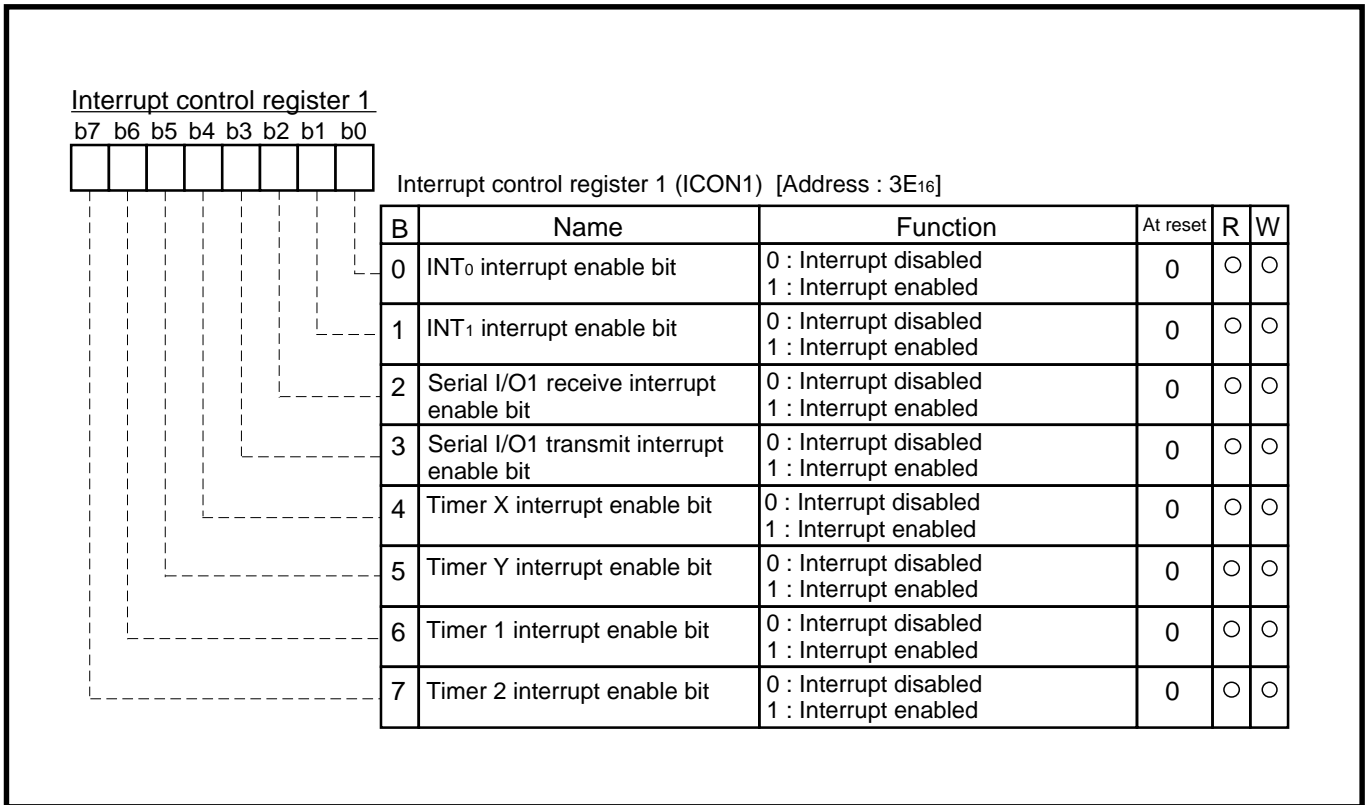

Fig. 3.5.21 Structure of Interrupt control register 1

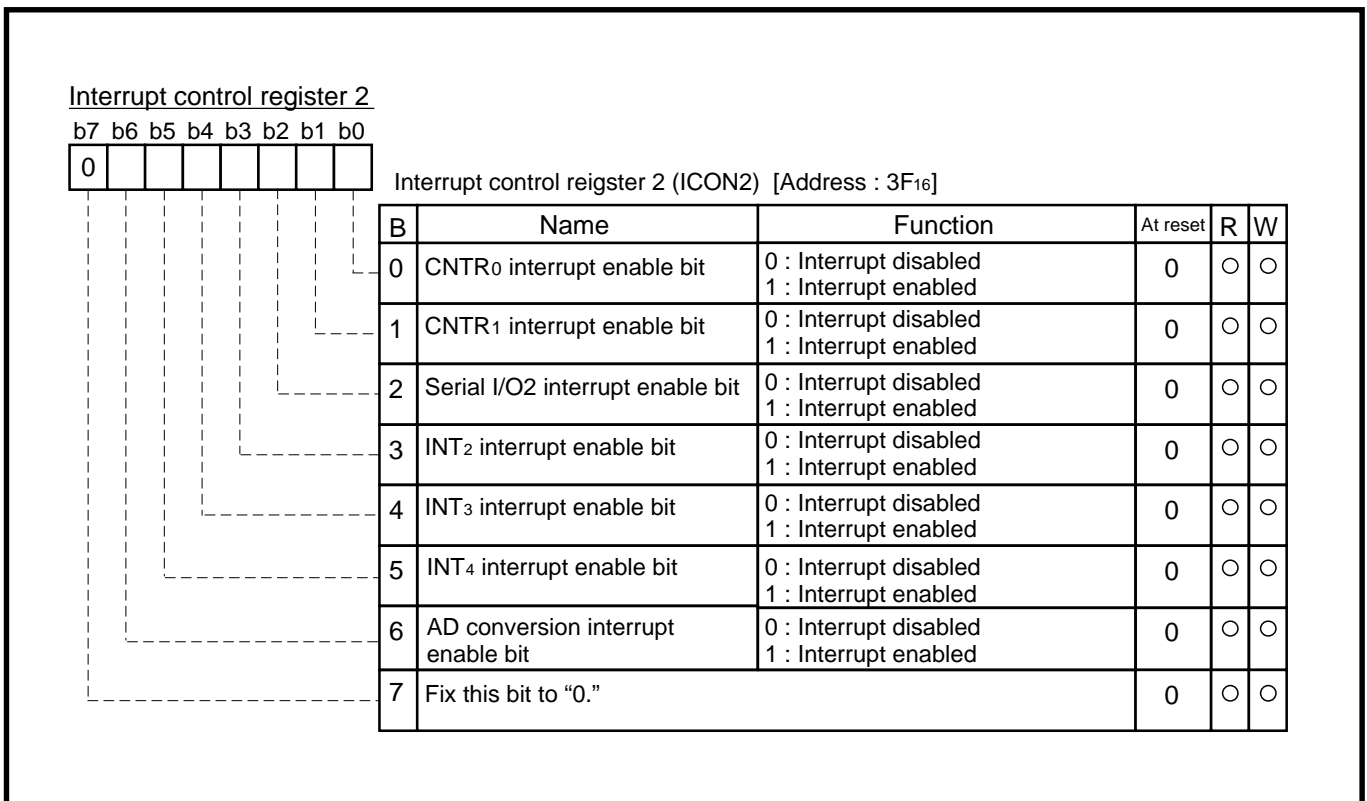

Fig. 3.5.22 Structure of Interrupt control register 2

## 3.6 Mask ROM ordering method

### 3.6 Mask ROM ordering method

GZZ-SH03-63B<07B0>

Mask ROM number	
-----------------	--

**740 FAMILY MASK ROM CONFIRMATION FORM  
SINGLE-CHIP MICROCOMPUTER M38062M3-XXXFP/GP  
MITSUBISHI ELECTRIC**

Receipt	Date:	
	Section head signature	Supervisor signature

Note : Please fill in all items marked \*.

* Customer	Company name	TEL ( )	Issuance signature	Submitted by	Supervisor
	Date issued	Date:			

\* 1. Confirmation

Specify the name of the product being ordered and the type of EPROMs submitted.

Three EPROMs are required for each pattern.

If at least two of the three sets of EPROMs submitted contain identical data, we will produce masks based on this data. We shall assume the responsibility for errors only if the mask ROM data on the products we produce differs from this data. Thus, extreme care must be taken to verify the data in the submitted EPROMs.

Microcomputer name :     M38062M3-XXXFP                       M38062M3-XXXGP

Checksum code for entire EPROM    

--	--	--	--

 (hexadecimal notation)

EPROM type (indicate the type used)

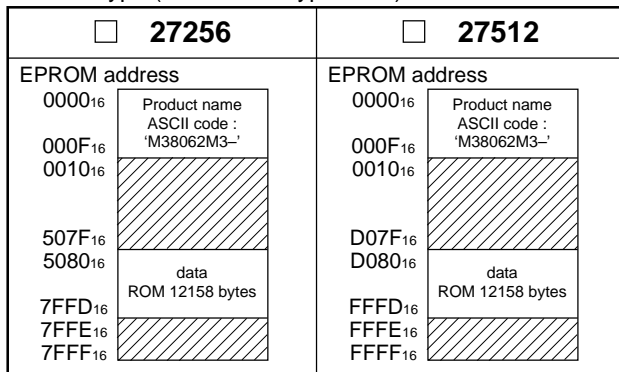

In the address space of the microcomputer, the internal ROM area is from address D080<sub>16</sub> to FFFD<sub>16</sub>. The reset vector is stored in addresses FFFC<sub>16</sub> and FFFD<sub>16</sub>.

- (1) Set the data in the unused area (the shaded area of the diagram) to "FF<sub>16</sub>".
- (2) The ASCII codes of the product name "M38062M3-" must be entered in addresses 0000<sub>16</sub> to 0008<sub>16</sub>. And set the data "FF<sub>16</sub>" in addresses 0009<sub>16</sub> to 000F<sub>16</sub>. The ASCII codes and addresses are listed to the right in hexadecimal notation.

<table style="width: 100%; border-collapse: collapse;"> <tr><td style="width: 20px;">Address</td><td></td></tr> <tr><td>0000<sub>16</sub></td><td style="border: 1px solid black; padding: 2px;">'M' = 4D<sub>16</sub></td></tr> <tr><td>0001<sub>16</sub></td><td style="border: 1px solid black; padding: 2px;">'3' = 33<sub>16</sub></td></tr> <tr><td>0002<sub>16</sub></td><td style="border: 1px solid black; padding: 2px;">'8' = 38<sub>16</sub></td></tr> <tr><td>0003<sub>16</sub></td><td style="border: 1px solid black; padding: 2px;">'0' = 30<sub>16</sub></td></tr> <tr><td>0004<sub>16</sub></td><td style="border: 1px solid black; padding: 2px;">'6' = 36<sub>16</sub></td></tr> <tr><td>0005<sub>16</sub></td><td style="border: 1px solid black; padding: 2px;">'2' = 32<sub>16</sub></td></tr> <tr><td>0006<sub>16</sub></td><td style="border: 1px solid black; padding: 2px;">'M' = 4D<sub>16</sub></td></tr> <tr><td>0007<sub>16</sub></td><td style="border: 1px solid black; padding: 2px;">'3' = 33<sub>16</sub></td></tr> </table>	Address		0000 <sub>16</sub>	'M' = 4D <sub>16</sub>	0001 <sub>16</sub>	'3' = 33 <sub>16</sub>	0002 <sub>16</sub>	'8' = 38 <sub>16</sub>	0003 <sub>16</sub>	'0' = 30 <sub>16</sub>	0004 <sub>16</sub>	'6' = 36 <sub>16</sub>	0005 <sub>16</sub>	'2' = 32 <sub>16</sub>	0006 <sub>16</sub>	'M' = 4D <sub>16</sub>	0007 <sub>16</sub>	'3' = 33 <sub>16</sub>	<table style="width: 100%; border-collapse: collapse;"> <tr><td style="width: 20px;">Address</td><td></td></tr> <tr><td>0008<sub>16</sub></td><td style="border: 1px solid black; padding: 2px;">'-' = 2D<sub>16</sub></td></tr> <tr><td>0009<sub>16</sub></td><td style="border: 1px solid black; padding: 2px;">FF<sub>16</sub></td></tr> <tr><td>000A<sub>16</sub></td><td style="border: 1px solid black; padding: 2px;">FF<sub>16</sub></td></tr> <tr><td>000B<sub>16</sub></td><td style="border: 1px solid black; padding: 2px;">FF<sub>16</sub></td></tr> <tr><td>000C<sub>16</sub></td><td style="border: 1px solid black; padding: 2px;">FF<sub>16</sub></td></tr> <tr><td>000D<sub>16</sub></td><td style="border: 1px solid black; padding: 2px;">FF<sub>16</sub></td></tr> <tr><td>000E<sub>16</sub></td><td style="border: 1px solid black; padding: 2px;">FF<sub>16</sub></td></tr> <tr><td>000F<sub>16</sub></td><td style="border: 1px solid black; padding: 2px;">FF<sub>16</sub></td></tr> </table>	Address		0008 <sub>16</sub>	'-' = 2D <sub>16</sub>	0009 <sub>16</sub>	FF <sub>16</sub>	000A <sub>16</sub>	FF <sub>16</sub>	000B <sub>16</sub>	FF <sub>16</sub>	000C <sub>16</sub>	FF <sub>16</sub>	000D <sub>16</sub>	FF <sub>16</sub>	000E <sub>16</sub>	FF <sub>16</sub>	000F <sub>16</sub>	FF <sub>16</sub>
Address																																					
0000 <sub>16</sub>	'M' = 4D <sub>16</sub>																																				
0001 <sub>16</sub>	'3' = 33 <sub>16</sub>																																				
0002 <sub>16</sub>	'8' = 38 <sub>16</sub>																																				
0003 <sub>16</sub>	'0' = 30 <sub>16</sub>																																				
0004 <sub>16</sub>	'6' = 36 <sub>16</sub>																																				
0005 <sub>16</sub>	'2' = 32 <sub>16</sub>																																				
0006 <sub>16</sub>	'M' = 4D <sub>16</sub>																																				
0007 <sub>16</sub>	'3' = 33 <sub>16</sub>																																				
Address																																					
0008 <sub>16</sub>	'-' = 2D <sub>16</sub>																																				
0009 <sub>16</sub>	FF <sub>16</sub>																																				
000A <sub>16</sub>	FF <sub>16</sub>																																				
000B <sub>16</sub>	FF <sub>16</sub>																																				
000C <sub>16</sub>	FF <sub>16</sub>																																				
000D <sub>16</sub>	FF <sub>16</sub>																																				
000E <sub>16</sub>	FF <sub>16</sub>																																				
000F <sub>16</sub>	FF <sub>16</sub>																																				

# APPENDIX

## 3.6 Mask ROM ordering method

---

GZZ-SH03-63B<07B0>

Mask ROM number	
-----------------	--

### 740 FAMILY MASK ROM CONFIRMATION FORM SINGLE-CHIP MICROCOMPUTER M38062M3-XXXFP/GP MITSUBISHI ELECTRIC

We recommend the use of the following pseudo-command to set the start address of the assembler source program.

EPROM type	27256	27512
The pseudo-command	*= $\Delta$ \$8000 .BYTE $\Delta$ 'M38062M3-'	*= $\Delta$ \$0000 .BYTE $\Delta$ 'M38062M3-'

Note : If the name of the product written to the EPROMs does not match the name of the mask confirmation form, the ROM will not be processed.

※ 2. Mark specification

Mark specification must be submitted using the correct form for the package being ordered. Fill out the appropriate mark specification form (80P6N for M38062M3-XXXFP, 80P6S for M38062M3-XXXGP) and attach it to the mask ROM confirmation form.

※ 3. Usage conditions

Please answer the following questions about usage for use in our product inspection :

(1) How will you use the X<sub>IN</sub>-X<sub>OUT</sub> oscillator?

- |   |   |
|---|---|
| <input type="checkbox"/> Ceramic resonator    | <input type="checkbox"/> Quartz crystal       |
| <input type="checkbox"/> External clock input | <input type="checkbox"/> Other (            ) |

At what frequency?                      f(X<sub>IN</sub>) =  MHz

(2) In which operation mode will you use your microcomputer?

- |  |  |
|--|--|
| <input type="checkbox"/> Single-chip mode    | <input type="checkbox"/> Memory expansion mode |
| <input type="checkbox"/> Microprocessor mode |  |

※ 4. Comments

(2/2)

## 3.6 Mask ROM ordering method

GZZ-SH04-80B<16A0>

Mask ROM number	
-----------------	--

### 740 FAMILY MASK ROM CONFIRMATION FORM SINGLE-CHIP MICROCOMPUTER M38062M3DXXXFP MITSUBISHI ELECTRIC

Receipt	Date:	
	Section head signature	Supervisor signature

Note : Please fill in all items marked \*.

*	Customer	Company name	TEL ( )	Issuance signature	Submitted by	Supervisor
		Date issued	Date:			

#### \* 1. Confirmation

Specify the type of EPROMs submitted.

Three EPROMs are required for each pattern.

If at least two of the three sets of EPROMs submitted contain identical data, we will produce masks based on this data. We shall assume the responsibility for errors only if the mask ROM data on the products we produce differs from this data. Thus, extreme care must be taken to verify the data in the submitted EPROMs.

Checksum code for entire EPROM

--	--	--	--

(hexadecimal notation)

EPROM type (indicate the type used)

<input type="checkbox"/> <b>27256</b>	<input type="checkbox"/> <b>27512</b>
<p>EPROM address</p> <p>0000<sub>16</sub> Product name ASCII code : 'M38062M3D'</p> <p>000F<sub>16</sub></p> <p>0010<sub>16</sub></p> <p>507F<sub>16</sub></p> <p>5080<sub>16</sub> data ROM 12158 bytes</p> <p>7FFD<sub>16</sub></p> <p>7FFE<sub>16</sub></p> <p>7FFF<sub>16</sub></p>	<p>EPROM address</p> <p>0000<sub>16</sub> Product name ASCII code : 'M38062M3D'</p> <p>000F<sub>16</sub></p> <p>0010<sub>16</sub></p> <p>D07F<sub>16</sub></p> <p>D080<sub>16</sub> data ROM 12158 bytes</p> <p>FFFD<sub>16</sub></p> <p>FFFE<sub>16</sub></p> <p>FFFF<sub>16</sub></p>

In the address space of the microcomputer, the internal ROM area is from address D080<sub>16</sub> to FFFD<sub>16</sub>. The reset vector is stored in addresses FFFC<sub>16</sub> and FFFD<sub>16</sub>.

- (1) Set the data in the unused area (the shaded area of the diagram) to "FF<sub>16</sub>".
- (2) The ASCII codes of the product name "M38062M3D" must be entered in addresses 0000<sub>16</sub> to 0008<sub>16</sub>. And set the data "FF<sub>16</sub>" in addresses 0009<sub>16</sub> to 000F<sub>16</sub>. The ASCII codes and addresses are listed to the right in hexadecimal notation.

Address

0000 <sub>16</sub>	'M' = 4D <sub>16</sub>
0001 <sub>16</sub>	'3' = 33 <sub>16</sub>
0002 <sub>16</sub>	'8' = 38 <sub>16</sub>
0003 <sub>16</sub>	'0' = 30 <sub>16</sub>
0004 <sub>16</sub>	'6' = 36 <sub>16</sub>
0005 <sub>16</sub>	'2' = 32 <sub>16</sub>
0006 <sub>16</sub>	'M' = 4D <sub>16</sub>
0007 <sub>16</sub>	'3' = 33 <sub>16</sub>

Address

0008 <sub>16</sub>	'D' = 44 <sub>16</sub>
0009 <sub>16</sub>	FF <sub>16</sub>
000A <sub>16</sub>	FF <sub>16</sub>
000B <sub>16</sub>	FF <sub>16</sub>
000C <sub>16</sub>	FF <sub>16</sub>
000D <sub>16</sub>	FF <sub>16</sub>
000E <sub>16</sub>	FF <sub>16</sub>
000F <sub>16</sub>	FF <sub>16</sub>

(1/2)

# APPENDIX

## 3.6 Mask ROM ordering method

---

GZZ-SH04-80B<16A0>

Mask ROM number	
-----------------	--

### 740 FAMILY MASK ROM CONFIRMATION FORM SINGLE-CHIP MICROCOMPUTER M38062M3DXXXFP MITSUBISHI ELECTRIC

We recommend the use of the following pseudo-command to set the start address of the assembler source program.

EPROM type	27256	27512
The pseudo-command	*= $\Delta$ \$8000 .BYTE $\Delta$ 'M38062M3D'	*= $\Delta$ \$0000 .BYTE $\Delta$ 'M38062M3D'

Note : If the name of the product written to the EPROMs does not match the name of the mask confirmation form, the ROM will not be processed.

※ 2. Mark specification

Mark specification must be submitted using the correct form for the package being ordered. Fill out the appropriate mark specification form (80P6N for M38062M3DXXXFP) and attach it to the mask ROM confirmation form.

※ 3. Usage conditions

Please answer the following questions about usage for use in our product inspection :

(1) How will you use the  $X_{IN}$ - $X_{OUT}$  oscillator?

- Ceramic resonator       Quartz crystal  
 External clock input       Other (            )

At what frequency?

$f(X_{IN}) =$   MHz

(2) In which operation mode will you use your microcomputer?

- Single-chip mode       Memory expansion mode  
 Microprocessor mode

※ 4. Comments

(2/2)

## 3.6 Mask ROM ordering method

GZZ-SH04-26B<13B0>

Mask ROM number	
-----------------	--

### 740 FAMILY MASK ROM CONFIRMATION FORM SINGLE-CHIP MICROCOMPUTER M38062M4-XXXFP/GP MITSUBISHI ELECTRIC

Receipt	Date:	
	Section head signature	Supervisor signature

Note : Please fill in all items marked \*.

*	Customer	Company name	TEL ( )	Issuance signature	Submitted by	Supervisor
		Date issued	Date:			

#### \* 1. Confirmation

Specify the name of the product being ordered and the type of EPROMs submitted.

Three EPROMs are required for each pattern.

If at least two of the three sets of EPROMs submitted contain identical data, we will produce masks based on this data. We shall assume the responsibility for errors only if the mask ROM data on the products we produce differs from this data. Thus, extreme care must be taken to verify the data in the submitted EPROMs.

Microcomputer name :     M38062M4-XXXFP                       M38062M4-XXXGP

Checksum code for entire EPROM    

--	--	--	--

 (hexadecimal notation)

EPROM type (indicate the type used)

<input type="checkbox"/> <b>27256</b> EPROM address 0000 <sub>16</sub> Product name ASCII code : 'M38062M4-' 000F <sub>16</sub> 0010 <sub>16</sub>  407F <sub>16</sub> 4080 <sub>16</sub> data ROM 16254 bytes 7FFD <sub>16</sub> 7FFE <sub>16</sub> 7FFF <sub>16</sub>	<input type="checkbox"/> <b>27512</b> EPROM address 0000 <sub>16</sub> Product name ASCII code : 'M38062M4-' 000F <sub>16</sub> 0010 <sub>16</sub>  C07F <sub>16</sub> C080 <sub>16</sub> data ROM 16254 bytes FFFD <sub>16</sub> FFFE <sub>16</sub> FFFF <sub>16</sub>
--	--

In the address space of the microcomputer, the internal ROM area is from address C080<sub>16</sub> to FFFD<sub>16</sub>. The reset vector is stored in addresses FFFC<sub>16</sub> and FFFD<sub>16</sub>.

- (1) Set the data in the unused area (the shaded area of the diagram) to "FF<sub>16</sub>".
- (2) The ASCII codes of the product name "M38062M4-" must be entered in addresses 0000<sub>16</sub> to 0008<sub>16</sub>. And set the data "FF<sub>16</sub>" in addresses 0009<sub>16</sub> to 000F<sub>16</sub>. The ASCII codes and addresses are listed to the right in hexadecimal notation.

Address		Address
0000 <sub>16</sub>	'M' = 4D <sub>16</sub>	0008 <sub>16</sub>
0001 <sub>16</sub>	'3' = 33 <sub>16</sub>	0009 <sub>16</sub>
0002 <sub>16</sub>	'8' = 38 <sub>16</sub>	000A <sub>16</sub>
0003 <sub>16</sub>	'0' = 30 <sub>16</sub>	000B <sub>16</sub>
0004 <sub>16</sub>	'6' = 36 <sub>16</sub>	000C <sub>16</sub>
0005 <sub>16</sub>	'2' = 32 <sub>16</sub>	000D <sub>16</sub>
0006 <sub>16</sub>	'M' = 4D <sub>16</sub>	000E <sub>16</sub>
0007 <sub>16</sub>	'4' = 34 <sub>16</sub>	000F <sub>16</sub>
		'-' = 2D <sub>16</sub>
		FF <sub>16</sub>
		FF <sub>16</sub>
		FF <sub>16</sub>
		FF <sub>16</sub>
		FF <sub>16</sub>
		FF <sub>16</sub>
		FF <sub>16</sub>

# APPENDIX

## 3.6 Mask ROM ordering method

---

GZZ-SH04-26B<13B0>

Mask ROM number	
-----------------	--

### 740 FAMILY MASK ROM CONFIRMATION FORM SINGLE-CHIP MICROCOMPUTER M38062M4-XXXFP/GP MITSUBISHI ELECTRIC

We recommend the use of the following pseudo-command to set the start address of the assembler source program.

EPROM type	27256	27512
The pseudo-command	*= $\Delta$ \$8000 .BYTE $\Delta$ 'M38062M4-'	*= $\Delta$ \$0000 .BYTE $\Delta$ 'M38062M4-'

Note : If the name of the product written to the EPROMs does not match the name of the mask confirmation form, the ROM will not be processed.

※ 2. Mark specification

Mark specification must be submitted using the correct form for the package being ordered. Fill out the appropriate mark specification form (80P6N for M38062M4-XXXFP, 80P6S for M38062M4-XXXGP) and attach it to the mask ROM confirmation form.

※ 3. Usage conditions

Please answer the following questions about usage for use in our product inspection :

(1) How will you use the X<sub>IN</sub>-X<sub>OUT</sub> oscillator?

- |   |   |
|---|---|
| <input type="checkbox"/> Ceramic resonator    | <input type="checkbox"/> Quartz crystal       |
| <input type="checkbox"/> External clock input | <input type="checkbox"/> Other (            ) |

At what frequency?                      f(X<sub>IN</sub>) =  MHz

(2) In which operation mode will you use your microcomputer?

- |  |  |
|--|--|
| <input type="checkbox"/> Single-chip mode    | <input type="checkbox"/> Memory expansion mode |
| <input type="checkbox"/> Microprocessor mode |  |

※ 4. Comments







## 3.6 Mask ROM ordering method

GZZ-SH03-26B<9ZC0>

Mask ROM number	
-----------------	--

### 740 FAMILY MASK ROM CONFIRMATION FORM SINGLE-CHIP MICROCOMPUTER M38063M6-XXXFP/GP MITSUBISHI ELECTRIC

Receipt	Date:	
	Section head signature	Supervisor signature

Note : Please fill in all items marked \*.

*	Customer	Company name	TEL (      )	Issuance signature	Submitted by	Supervisor
		Date issued	Date:			

#### \* 1. Confirmation

Specify the name of the product being ordered and the type of EPROMs submitted.

Three EPROMs are required for each pattern.

If at least two of the three sets of EPROMs submitted contain identical data, we will produce masks based on this data. We shall assume the responsibility for errors only if the mask ROM data on the products we produce differs from this data. Thus, extreme care must be taken to verify the data in the submitted EPROMs.

Microcomputer name :     M38063M6-XXXFP                       M38063M6-XXXGP

Checksum code for entire EPROM    

--	--	--	--

 (hexadecimal notation)

EPROM type (indicate the type used)

<input type="checkbox"/> <b>27256</b> EPROM address 0000 <sub>16</sub> Product name ASCII code : 'M38063M6-' 000F <sub>16</sub> 0010 <sub>16</sub>  207F <sub>16</sub> 2080 <sub>16</sub> data ROM 24446 bytes 7FFD <sub>16</sub> 7FFE <sub>16</sub> 7FFF <sub>16</sub>	<input type="checkbox"/> <b>27512</b> EPROM address 0000 <sub>16</sub> Product name ASCII code : 'M38063M6-' 000F <sub>16</sub> 0010 <sub>16</sub>  A07F <sub>16</sub> A080 <sub>16</sub> data ROM 24446 bytes FFFD <sub>16</sub> FFFE <sub>16</sub> FFFF <sub>16</sub>
--	--

In the address space of the microcomputer, the internal ROM area is from address A080<sub>16</sub> to FFFD<sub>16</sub>. The reset vector is stored in addresses FFFC<sub>16</sub> and FFFD<sub>16</sub>.

- (1) Set the data in the unused area (the shaded area of the diagram) to "FF<sub>16</sub>".
- (2) The ASCII codes of the product name "M38063M6-" must be entered in addresses 0000<sub>16</sub> to 0008<sub>16</sub>. And set the data "FF<sub>16</sub>" in addresses 0009<sub>16</sub> to 000F<sub>16</sub>. The ASCII codes and addresses are listed to the right in hexadecimal notation.

Address		Address
0000 <sub>16</sub>	'M' = 4D <sub>16</sub>	0008 <sub>16</sub>
0001 <sub>16</sub>	'3' = 33 <sub>16</sub>	0009 <sub>16</sub>
0002 <sub>16</sub>	'8' = 38 <sub>16</sub>	000A <sub>16</sub>
0003 <sub>16</sub>	'0' = 30 <sub>16</sub>	000B <sub>16</sub>
0004 <sub>16</sub>	'6' = 36 <sub>16</sub>	000C <sub>16</sub>
0005 <sub>16</sub>	'3' = 33 <sub>16</sub>	000D <sub>16</sub>
0006 <sub>16</sub>	'M' = 4D <sub>16</sub>	000E <sub>16</sub>
0007 <sub>16</sub>	'6' = 36 <sub>16</sub>	000F <sub>16</sub>
		'-' = 2D <sub>16</sub>
		FF <sub>16</sub>
		FF <sub>16</sub>
		FF <sub>16</sub>
		FF <sub>16</sub>
		FF <sub>16</sub>
		FF <sub>16</sub>
		FF <sub>16</sub>



## 3.6 Mask ROM ordering method

GZZ-SH07-64B<36B0>

Mask ROM number	
-----------------	--

### 740 FAMILY MASK ROM CONFIRMATION FORM SINGLE-CHIP MICROCOMPUTER M38063M6AXXFP/GP/HP MITSUBISHI ELECTRIC

Receipt	Date:	
	Section head signature	Supervisor signature

Note : Please fill in all items marked \*.

*	Customer	Company name	TEL ( )	Issuance signature	Submitted by	Supervisor
		Date issued	Date:			

#### \* 1. Confirmation

Specify the name of the product being ordered and the type of EPROMs submitted.

Three EPROMs are required for each pattern.

If at least two of the three sets of EPROMs submitted contain identical data, we will produce masks based on this data. We shall assume the responsibility for errors only if the mask ROM data on the products we produce differs from this data. Thus, extreme care must be taken to verify the data in the submitted EPROMs.

Microcomputer name :     M38063M6AXXFP     M38063M6AXXGP     M38063M6AXXHP

Checksum code for entire EPROM 

--	--	--	--

 (hexadecimal notation)

EPROM type (indicate the type used)

<input type="checkbox"/> <b>27256</b> EPROM address 0000 <sub>16</sub> Product name ASCII code : 'M38063M6A' 000F <sub>16</sub> 0010 <sub>16</sub>  207F <sub>16</sub> 2080 <sub>16</sub> data ROM 24446 bytes 7FFD <sub>16</sub> 7FFE <sub>16</sub> 7FFF <sub>16</sub>	<input type="checkbox"/> <b>27512</b> EPROM address 0000 <sub>16</sub> Product name ASCII code : 'M38063M6A' 000F <sub>16</sub> 0010 <sub>16</sub>  A07F <sub>16</sub> A080 <sub>16</sub> data ROM 24446 bytes FFFD <sub>16</sub> FFFE <sub>16</sub> FFFF <sub>16</sub>
--	--

In the address space of the microcomputer, the internal ROM area is from address A080<sub>16</sub> to FFFD<sub>16</sub>. The reset vector is stored in addresses FFFC<sub>16</sub> and FFFD<sub>16</sub>.

- (1) Set the data in the unused area (the shaded area of the diagram) to "FF<sub>16</sub>".
- (2) The ASCII codes of the product name "M38063M6A" must be entered in addresses 0000<sub>16</sub> to 0008<sub>16</sub>. And set the data "FF<sub>16</sub>" in addresses 0009<sub>16</sub> to 000F<sub>16</sub>. The ASCII codes and addresses are listed to the right in hexadecimal notation.

Address		Address	
0000 <sub>16</sub>	'M' = 4D <sub>16</sub>	0008 <sub>16</sub>	'A' = 41 <sub>16</sub>
0001 <sub>16</sub>	'3' = 33 <sub>16</sub>	0009 <sub>16</sub>	FF <sub>16</sub>
0002 <sub>16</sub>	'8' = 38 <sub>16</sub>	000A <sub>16</sub>	FF <sub>16</sub>
0003 <sub>16</sub>	'0' = 30 <sub>16</sub>	000B <sub>16</sub>	FF <sub>16</sub>
0004 <sub>16</sub>	'6' = 36 <sub>16</sub>	000C <sub>16</sub>	FF <sub>16</sub>
0005 <sub>16</sub>	'3' = 33 <sub>16</sub>	000D <sub>16</sub>	FF <sub>16</sub>
0006 <sub>16</sub>	'M' = 4D <sub>16</sub>	000E <sub>16</sub>	FF <sub>16</sub>
0007 <sub>16</sub>	'6' = 36 <sub>16</sub>	000F <sub>16</sub>	FF <sub>16</sub>

# APPENDIX

## 3.6 Mask ROM ordering method

---

GZZ-SH07-64B<36B0>

Mask ROM number	
-----------------	--

### 740 FAMILY MASK ROM CONFIRMATION FORM SINGLE-CHIP MICROCOMPUTER M38063M6AXXFP/GP/HP MITSUBISHI ELECTRIC

We recommend the use of the following pseudo-command to set the start address of the assembler source program.

EPROM type	27256	27512
The pseudo-command	*= $\Delta$ \$8000 .BYTE $\Delta$ 'M38063M6A'	*= $\Delta$ \$0000 .BYTE $\Delta$ 'M38063M6A'

Note : If the name of the product written to the EPROMs does not match the name of the mask confirmation form, the ROM will not be processed.

※ 2. Mark specification

Mark specification must be submitted using the correct form for the package being ordered. Fill out the appropriate mark specification form (80P6N for M38063M6AXXFP, 80P6S for M38063M6AXXGP, 80P6D for M38063M6AXXHP) and attach it to the mask ROM confirmation form.

※ 3. Usage conditions

Please answer the following questions about usage for use in our product inspection :

(1) How will you use the X<sub>IN</sub>-X<sub>OUT</sub> oscillator?

- |   |   |
|---|---|
| <input type="checkbox"/> Ceramic resonator    | <input type="checkbox"/> Quartz crystal       |
| <input type="checkbox"/> External clock input | <input type="checkbox"/> Other (            ) |

At what frequency?                      f(X<sub>IN</sub>) =  MHz

(2) In which operation mode will you use your microcomputer?

- |  |  |
|--|--|
| <input type="checkbox"/> Single-chip mode    | <input type="checkbox"/> Memory expansion mode |
| <input type="checkbox"/> Microprocessor mode |  |

※ 4. Comments

(2/2)

## 3.6 Mask ROM ordering method

GZZ-SH04-72B<15A0>

Mask ROM number	
-----------------	--

### 740 FAMILY MASK ROM CONFIRMATION FORM SINGLE-CHIP MICROCOMPUTER M38063M6DXXXFP MITSUBISHI ELECTRIC

Receipt	Date:	
	Section head signature	Supervisor signature

Note : Please fill in all items marked \*.

*	Customer	Company name	TEL (      )	Issuance signature	Submitted by	Supervisor
		Date issued	Date:			

#### \* 1. Confirmation

Specify the type of EPROMs submitted.

Three EPROMs are required for each pattern.

If at least two of the three sets of EPROMs submitted contain identical data, we will produce masks based on this data. We shall assume the responsibility for errors only if the mask ROM data on the products we produce differs from this data. Thus, extreme care must be taken to verify the data in the submitted EPROMs.

Checksum code for entire EPROM

--	--	--	--

(hexadecimal notation)

EPROM type (indicate the type used)

<input type="checkbox"/> <b>27256</b>	<input type="checkbox"/> <b>27512</b>
<p>EPROM address</p> <p>0000<sub>16</sub>    Product name                   ASCII code :                   'M38063M6D'</p> <p>000F<sub>16</sub> 0010<sub>16</sub>    </p> <p>207F<sub>16</sub> 2080<sub>16</sub>    data                   ROM 24446 bytes</p> <p>7FFD<sub>16</sub> 7FFE<sub>16</sub> 7FFF<sub>16</sub>    </p>	<p>EPROM address</p> <p>0000<sub>16</sub>    Product name                   ASCII code :                   'M38063M6D'</p> <p>000F<sub>16</sub> 0010<sub>16</sub>    </p> <p>A07F<sub>16</sub> A080<sub>16</sub>    data                   ROM 24446 bytes</p> <p>FFFD<sub>16</sub> FFFE<sub>16</sub> FFFF<sub>16</sub>    </p>

In the address space of the microcomputer, the internal ROM area is from address A080<sub>16</sub> to FFFD<sub>16</sub>. The reset vector is stored in addresses FFFC<sub>16</sub> and FFFD<sub>16</sub>.

- (1) Set the data in the unused area (the shaded area of the diagram) to "FF<sub>16</sub>".
- (2) The ASCII codes of the product name "M38063M6D" must be entered in addresses 0000<sub>16</sub> to 0008<sub>16</sub>. And set the data "FF<sub>16</sub>" in addresses 0009<sub>16</sub> to 000F<sub>16</sub>. The ASCII codes and addresses are listed to the right in hexadecimal notation.

Address

0000 <sub>16</sub>	'M' = 4D <sub>16</sub>
0001 <sub>16</sub>	'3' = 33 <sub>16</sub>
0002 <sub>16</sub>	'8' = 38 <sub>16</sub>
0003 <sub>16</sub>	'0' = 30 <sub>16</sub>
0004 <sub>16</sub>	'6' = 36 <sub>16</sub>
0005 <sub>16</sub>	'3' = 33 <sub>16</sub>
0006 <sub>16</sub>	'M' = 4D <sub>16</sub>
0007 <sub>16</sub>	'6' = 36 <sub>16</sub>

Address

0008 <sub>16</sub>	'D' = 44 <sub>16</sub>
0009 <sub>16</sub>	FF <sub>16</sub>
000A <sub>16</sub>	FF <sub>16</sub>
000B <sub>16</sub>	FF <sub>16</sub>
000C <sub>16</sub>	FF <sub>16</sub>
000D <sub>16</sub>	FF <sub>16</sub>
000E <sub>16</sub>	FF <sub>16</sub>
000F <sub>16</sub>	FF <sub>16</sub>

(1/2)

# APPENDIX

## 3.6 Mask ROM ordering method

---

GZZ-SH04-72B<15A0>

Mask ROM number	
-----------------	--

### 740 FAMILY MASK ROM CONFIRMATION FORM SINGLE-CHIP MICROCOMPUTER M38063M6DXXXFP MITSUBISHI ELECTRIC

We recommend the use of the following pseudo-command to set the start address of the assembler source program.

EPROM type	27256	27512
The pseudo-command	*= $\Delta$ \$8000 .BYTE $\Delta$ 'M38063M6D'	*= $\Delta$ \$0000 .BYTE $\Delta$ 'M38063M6D'

Note : If the name of the product written to the EPROMs does not match the name of the mask confirmation form, the ROM will not be processed.

※ 2. Mark specification

Mark specification must be submitted using the correct form for the package being ordered. Fill out the appropriate mark specification form (80P6N for M38063M6DXXXFP) and attach it to the mask ROM confirmation form.

※ 3. Usage conditions

Please answer the following questions about usage for use in our product inspection :

(1) How will you use the X<sub>IN</sub>-X<sub>OUT</sub> oscillator?

- Ceramic resonator       Quartz crystal  
 External clock input       Other (            )

At what frequency?       $f(X_{IN}) =$   MHz

(2) In which operation mode will you use your microcomputer?

- Single-chip mode       Memory expansion mode  
 Microprocessor mode

※ 4. Comments

(2/2)

## 3.6 Mask ROM ordering method

GZZ-SH04-87B<17B0>

Mask ROM number	
-----------------	--

### 740 FAMILY MASK ROM CONFIRMATION FORM SINGLE-CHIP MICROCOMPUTER M38067M8-XXXFP/GP MITSUBISHI ELECTRIC

Receipt	Date:	
	Section head signature	Supervisor signature

Note : Please fill in all items marked \*.

* Customer	Company name	TEL (      )	Issuance signature	Submitted by	Supervisor
	Date issued	Date:			

#### \* 1. Confirmation

Specify the name of the product being ordered and the type of EPROMs submitted.

Three EPROMs are required for each pattern.

If at least two of the three sets of EPROMs submitted contain identical data, we will produce masks based on this data. We shall assume the responsibility for errors only if the mask ROM data on the products we produce differs from this data. Thus, extreme care must be taken to verify the data in the submitted EPROMs.

Microcomputer name :     M38067M8-XXXFP                       M38067M8-XXXGP

Checksum code for entire EPROM    

--	--	--	--

 (hexadecimal notation)

EPROM type (indicate the type used)

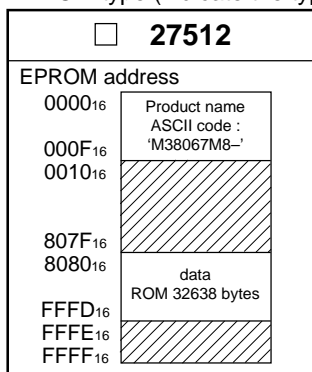

In the address space of the microcomputer, the internal ROM area is from address 8080<sub>16</sub> to FFFD<sub>16</sub>. The reset vector is stored in addresses FFFC<sub>16</sub> and FFFD<sub>16</sub>.

- (1) Set the data in the unused area (the shaded area of the diagram) to "FF<sub>16</sub>".
- (2) The ASCII codes of the product name "M38067M8-" must be entered in addresses 0000<sub>16</sub> to 0008<sub>16</sub>. And set the data "FF<sub>16</sub>" in addresses 0009<sub>16</sub> to 000F<sub>16</sub>. The ASCII codes and addresses are listed to the right in hexadecimal notation.

Address	<table border="1" style="width: 100%; border-collapse: collapse;"> <tr><td>0000<sub>16</sub></td><td>'M' = 4D<sub>16</sub></td></tr> <tr><td>0001<sub>16</sub></td><td>'3' = 33<sub>16</sub></td></tr> <tr><td>0002<sub>16</sub></td><td>'8' = 38<sub>16</sub></td></tr> <tr><td>0003<sub>16</sub></td><td>'0' = 30<sub>16</sub></td></tr> <tr><td>0004<sub>16</sub></td><td>'6' = 36<sub>16</sub></td></tr> <tr><td>0005<sub>16</sub></td><td>'7' = 37<sub>16</sub></td></tr> <tr><td>0006<sub>16</sub></td><td>'M' = 4D<sub>16</sub></td></tr> <tr><td>0007<sub>16</sub></td><td>'8' = 38<sub>16</sub></td></tr> </table>	0000 <sub>16</sub>	'M' = 4D <sub>16</sub>	0001 <sub>16</sub>	'3' = 33 <sub>16</sub>	0002 <sub>16</sub>	'8' = 38 <sub>16</sub>	0003 <sub>16</sub>	'0' = 30 <sub>16</sub>	0004 <sub>16</sub>	'6' = 36 <sub>16</sub>	0005 <sub>16</sub>	'7' = 37 <sub>16</sub>	0006 <sub>16</sub>	'M' = 4D <sub>16</sub>	0007 <sub>16</sub>	'8' = 38 <sub>16</sub>	Address	<table border="1" style="width: 100%; border-collapse: collapse;"> <tr><td>0008<sub>16</sub></td><td>'-' = 2D<sub>16</sub></td></tr> <tr><td>0009<sub>16</sub></td><td>FF<sub>16</sub></td></tr> <tr><td>000A<sub>16</sub></td><td>FF<sub>16</sub></td></tr> <tr><td>000B<sub>16</sub></td><td>FF<sub>16</sub></td></tr> <tr><td>000C<sub>16</sub></td><td>FF<sub>16</sub></td></tr> <tr><td>000D<sub>16</sub></td><td>FF<sub>16</sub></td></tr> <tr><td>000E<sub>16</sub></td><td>FF<sub>16</sub></td></tr> <tr><td>000F<sub>16</sub></td><td>FF<sub>16</sub></td></tr> </table>	0008 <sub>16</sub>	'-' = 2D <sub>16</sub>	0009 <sub>16</sub>	FF <sub>16</sub>	000A <sub>16</sub>	FF <sub>16</sub>	000B <sub>16</sub>	FF <sub>16</sub>	000C <sub>16</sub>	FF <sub>16</sub>	000D <sub>16</sub>	FF <sub>16</sub>	000E <sub>16</sub>	FF <sub>16</sub>	000F <sub>16</sub>	FF <sub>16</sub>
0000 <sub>16</sub>	'M' = 4D <sub>16</sub>																																		
0001 <sub>16</sub>	'3' = 33 <sub>16</sub>																																		
0002 <sub>16</sub>	'8' = 38 <sub>16</sub>																																		
0003 <sub>16</sub>	'0' = 30 <sub>16</sub>																																		
0004 <sub>16</sub>	'6' = 36 <sub>16</sub>																																		
0005 <sub>16</sub>	'7' = 37 <sub>16</sub>																																		
0006 <sub>16</sub>	'M' = 4D <sub>16</sub>																																		
0007 <sub>16</sub>	'8' = 38 <sub>16</sub>																																		
0008 <sub>16</sub>	'-' = 2D <sub>16</sub>																																		
0009 <sub>16</sub>	FF <sub>16</sub>																																		
000A <sub>16</sub>	FF <sub>16</sub>																																		
000B <sub>16</sub>	FF <sub>16</sub>																																		
000C <sub>16</sub>	FF <sub>16</sub>																																		
000D <sub>16</sub>	FF <sub>16</sub>																																		
000E <sub>16</sub>	FF <sub>16</sub>																																		
000F <sub>16</sub>	FF <sub>16</sub>																																		





## 3.6 Mask ROM ordering method

GZZ-SH07-63B<36B0>

Mask ROM number	
-----------------	--

### 740 FAMILY MASK ROM CONFIRMATION FORM SINGLE-CHIP MICROCOMPUTER M38067M8AXXFP/GP MITSUBISHI ELECTRIC

Receipt	Date:	
	Section head signature	Supervisor signature

Note : Please fill in all items marked \*.

* Customer	Company name	TEL (      )	Issuance signature	Submitted by	Supervisor
	Date issued	Date:			

#### \* 1. Confirmation

Specify the name of the product being ordered and the type of EPROMs submitted.

Three EPROMs are required for each pattern.

If at least two of the three sets of EPROMs submitted contain identical data, we will produce masks based on this data. We shall assume the responsibility for errors only if the mask ROM data on the products we produce differs from this data. Thus, extreme care must be taken to verify the data in the submitted EPROMs.

Microcomputer name :     M38067M8AXXFP                       M38067M8AXXGP

Checksum code for entire EPROM    

--	--	--	--

 (hexadecimal notation)

EPROM type (indicate the type used)

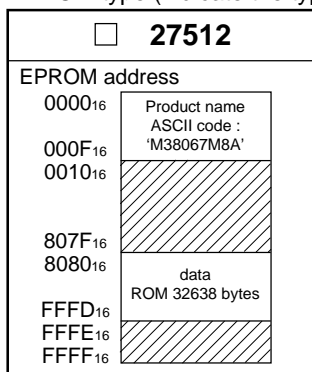

In the address space of the microcomputer, the internal ROM area is from address 8080<sub>16</sub> to FFFD<sub>16</sub>. The reset vector is stored in addresses FFFC<sub>16</sub> and FFFD<sub>16</sub>.

- (1) Set the data in the unused area (the shaded area of the diagram) to "FF<sub>16</sub>".
- (2) The ASCII codes of the product name "M38067M8A" must be entered in addresses 0000<sub>16</sub> to 0008<sub>16</sub>. And set the data "FF<sub>16</sub>" in addresses 0009<sub>16</sub> to 000F<sub>16</sub>. The ASCII codes and addresses are listed to the right in hexadecimal notation.

<table border="1" style="width: 100%; border-collapse: collapse;"> <tr><td>Address</td><td></td></tr> <tr><td>0000<sub>16</sub></td><td>'M' = 4D<sub>16</sub></td></tr> <tr><td>0001<sub>16</sub></td><td>'3' = 33<sub>16</sub></td></tr> <tr><td>0002<sub>16</sub></td><td>'8' = 38<sub>16</sub></td></tr> <tr><td>0003<sub>16</sub></td><td>'0' = 30<sub>16</sub></td></tr> <tr><td>0004<sub>16</sub></td><td>'6' = 36<sub>16</sub></td></tr> <tr><td>0005<sub>16</sub></td><td>'7' = 37<sub>16</sub></td></tr> <tr><td>0006<sub>16</sub></td><td>'M' = 4D<sub>16</sub></td></tr> <tr><td>0007<sub>16</sub></td><td>'8' = 38<sub>16</sub></td></tr> </table>	Address		0000 <sub>16</sub>	'M' = 4D <sub>16</sub>	0001 <sub>16</sub>	'3' = 33 <sub>16</sub>	0002 <sub>16</sub>	'8' = 38 <sub>16</sub>	0003 <sub>16</sub>	'0' = 30 <sub>16</sub>	0004 <sub>16</sub>	'6' = 36 <sub>16</sub>	0005 <sub>16</sub>	'7' = 37 <sub>16</sub>	0006 <sub>16</sub>	'M' = 4D <sub>16</sub>	0007 <sub>16</sub>	'8' = 38 <sub>16</sub>	<table border="1" style="width: 100%; border-collapse: collapse;"> <tr><td>Address</td><td></td></tr> <tr><td>0008<sub>16</sub></td><td>'A' = 41<sub>16</sub></td></tr> <tr><td>0009<sub>16</sub></td><td>FF<sub>16</sub></td></tr> <tr><td>000A<sub>16</sub></td><td>FF<sub>16</sub></td></tr> <tr><td>000B<sub>16</sub></td><td>FF<sub>16</sub></td></tr> <tr><td>000C<sub>16</sub></td><td>FF<sub>16</sub></td></tr> <tr><td>000D<sub>16</sub></td><td>FF<sub>16</sub></td></tr> <tr><td>000E<sub>16</sub></td><td>FF<sub>16</sub></td></tr> <tr><td>000F<sub>16</sub></td><td>FF<sub>16</sub></td></tr> </table>	Address		0008 <sub>16</sub>	'A' = 41 <sub>16</sub>	0009 <sub>16</sub>	FF <sub>16</sub>	000A <sub>16</sub>	FF <sub>16</sub>	000B <sub>16</sub>	FF <sub>16</sub>	000C <sub>16</sub>	FF <sub>16</sub>	000D <sub>16</sub>	FF <sub>16</sub>	000E <sub>16</sub>	FF <sub>16</sub>	000F <sub>16</sub>	FF <sub>16</sub>
Address																																					
0000 <sub>16</sub>	'M' = 4D <sub>16</sub>																																				
0001 <sub>16</sub>	'3' = 33 <sub>16</sub>																																				
0002 <sub>16</sub>	'8' = 38 <sub>16</sub>																																				
0003 <sub>16</sub>	'0' = 30 <sub>16</sub>																																				
0004 <sub>16</sub>	'6' = 36 <sub>16</sub>																																				
0005 <sub>16</sub>	'7' = 37 <sub>16</sub>																																				
0006 <sub>16</sub>	'M' = 4D <sub>16</sub>																																				
0007 <sub>16</sub>	'8' = 38 <sub>16</sub>																																				
Address																																					
0008 <sub>16</sub>	'A' = 41 <sub>16</sub>																																				
0009 <sub>16</sub>	FF <sub>16</sub>																																				
000A <sub>16</sub>	FF <sub>16</sub>																																				
000B <sub>16</sub>	FF <sub>16</sub>																																				
000C <sub>16</sub>	FF <sub>16</sub>																																				
000D <sub>16</sub>	FF <sub>16</sub>																																				
000E <sub>16</sub>	FF <sub>16</sub>																																				
000F <sub>16</sub>	FF <sub>16</sub>																																				



## 3.6 Mask ROM ordering method

GZZ-SH04-89B<17A0>

Mask ROM number	
-----------------	--

**740 FAMILY MASK ROM CONFIRMATION FORM  
SINGLE-CHIP MICROCOMPUTER M38067M8DXXXFP  
MITSUBISHI ELECTRIC**

Receipt	Date:	
	Section head signature	Supervisor signature

Note : Please fill in all items marked \*.

*	Customer	Company name	TEL (      )	Issuance signature	Submitted by	Supervisor
		Date issued	Date:			

\* 1. Confirmation

Specify the type of EPROMs submitted.

Three EPROMs are required for each pattern.

If at least two of the three sets of EPROMs submitted contain identical data, we will produce masks based on this data. We shall assume the responsibility for errors only if the mask ROM data on the products we produce differs from this data. Thus, extreme care must be taken to verify the data in the submitted EPROMs.

Checksum code for entire EPROM

--	--	--	--

(hexadecimal notation)

EPROM type (indicate the type used)

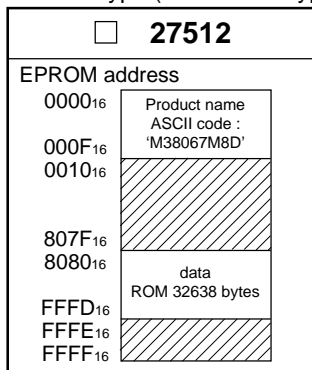

In the address space of the microcomputer, the internal ROM area is from address 8080<sub>16</sub> to FFFD<sub>16</sub>. The reset vector is stored in addresses FFFC<sub>16</sub> and FFFD<sub>16</sub>.

- Set the data in the unused area (the shaded area of the diagram) to "FF<sub>16</sub>".
- The ASCII codes of the product name "M38067M8D" must be entered in addresses 0000<sub>16</sub> to 0008<sub>16</sub>. And set the data "FF<sub>16</sub>" in addresses 0009<sub>16</sub> to 000F<sub>16</sub>. The ASCII codes and addresses are listed to the right in hexadecimal notation.

Address

0000 <sub>16</sub>	'M' = 4D <sub>16</sub>
0001 <sub>16</sub>	'3' = 33 <sub>16</sub>
0002 <sub>16</sub>	'8' = 38 <sub>16</sub>
0003 <sub>16</sub>	'0' = 30 <sub>16</sub>
0004 <sub>16</sub>	'6' = 36 <sub>16</sub>
0005 <sub>16</sub>	'7' = 37 <sub>16</sub>
0006 <sub>16</sub>	'M' = 4D <sub>16</sub>
0007 <sub>16</sub>	'8' = 38 <sub>16</sub>

Address

0008 <sub>16</sub>	'D' = 44 <sub>16</sub>
0009 <sub>16</sub>	FF <sub>16</sub>
000A <sub>16</sub>	FF <sub>16</sub>
000B <sub>16</sub>	FF <sub>16</sub>
000C <sub>16</sub>	FF <sub>16</sub>
000D <sub>16</sub>	FF <sub>16</sub>
000E <sub>16</sub>	FF <sub>16</sub>
000F <sub>16</sub>	FF <sub>16</sub>

# APPENDIX

## 3.6 Mask ROM ordering method

---

GZZ-SH04-89B<17A0>

Mask ROM number	
-----------------	--

### 740 FAMILY MASK ROM CONFIRMATION FORM SINGLE-CHIP MICROCOMPUTER M38067M8DXXXFP MITSUBISHI ELECTRIC

We recommend the use of the following pseudo-command to set the start address of the assembler source program.

EPROM type	27512
The pseudo-command	*= $\Delta$ \$0000 .BYTE $\Delta$ 'M38067M8D'

Note : If the name of the product written to the EPROMs does not match the name of the mask confirmation form, the ROM will not be processed.

※ 2. Mark specification

Mark specification must be submitted using the correct form for the package being ordered. Fill out the appropriate mark specification form (80P6N for M38067M8DXXXFP) and attach it to the mask ROM confirmation form.

※ 3. Usage conditions

Please answer the following questions about usage for use in our product inspection :

(1) How will you use the X<sub>IN</sub>-X<sub>OUT</sub> oscillator?

- |   |   |
|---|---|
| <input type="checkbox"/> Ceramic resonator    | <input type="checkbox"/> Quartz crystal       |
| <input type="checkbox"/> External clock input | <input type="checkbox"/> Other (            ) |

At what frequency?                      f(X<sub>IN</sub>) =  MHz

(2) In which operation mode will you use your microcomputer?

- |  |  |
|--|--|
| <input type="checkbox"/> Single-chip mode    | <input type="checkbox"/> Memory expansion mode |
| <input type="checkbox"/> Microprocessor mode |  |

※ 4. Comments

(2/2)

## 3.6 Mask ROM ordering method

GZZ-SH07-53B<35A0>

Mask ROM number	
-----------------	--

### 740 FAMILY MASK ROM CONFIRMATION FORM SINGLE-CHIP MICROCOMPUTER M38067MC-XXXFP/GP MITSUBISHI ELECTRIC

Receipt	Date:	
	Section head signature	Supervisor signature

Note : Please fill in all items marked \*.

* Customer	Company name	TEL (      )	Issuance signature	Submitted by	Supervisor
	Date issued	Date:			

#### \* 1. Confirmation

Specify the name of the product being ordered and the type of EPROMs submitted.

Three EPROMs are required for each pattern.

If at least two of the three sets of EPROMs submitted contain identical data, we will produce masks based on this data. We shall assume the responsibility for errors only if the mask ROM data on the products we produce differs from this data. Thus, extreme care must be taken to verify the data in the submitted EPROMs.

Microcomputer name :     M38067MC-XXXFP                       M38067MC-XXXGP

Checksum code for entire EPROM    

--	--	--	--

 (hexadecimal notation)

EPROM type (indicate the type used)

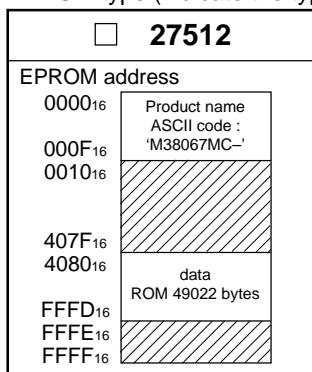

In the address space of the microcomputer, the internal ROM area is from address 4080<sub>16</sub> to FFFD<sub>16</sub>. The reset vector is stored in addresses FFFC<sub>16</sub> and FFFD<sub>16</sub>.

- (1) Set the data in the unused area (the shaded area of the diagram) to "FF<sub>16</sub>".
- (2) The ASCII codes of the product name "M38067MC-" must be entered in addresses 0000<sub>16</sub> to 0008<sub>16</sub>. And set the data "FF<sub>16</sub>" in addresses 0009<sub>16</sub> to 000F<sub>16</sub>. The ASCII codes and addresses are listed to the right in hexadecimal notation.

Address	'M' = 4D <sub>16</sub>	Address	'-' = 2D <sub>16</sub>
0000 <sub>16</sub>		0008 <sub>16</sub>	
0001 <sub>16</sub>	'3' = 33 <sub>16</sub>	0009 <sub>16</sub>	FF <sub>16</sub>
0002 <sub>16</sub>	'8' = 38 <sub>16</sub>	000A <sub>16</sub>	FF <sub>16</sub>
0003 <sub>16</sub>	'0' = 30 <sub>16</sub>	000B <sub>16</sub>	FF <sub>16</sub>
0004 <sub>16</sub>	'6' = 36 <sub>16</sub>	000C <sub>16</sub>	FF <sub>16</sub>
0005 <sub>16</sub>	'7' = 37 <sub>16</sub>	000D <sub>16</sub>	FF <sub>16</sub>
0006 <sub>16</sub>	'M' = 4D <sub>16</sub>	000E <sub>16</sub>	FF <sub>16</sub>
0007 <sub>16</sub>	'C' = 43 <sub>16</sub>	000F <sub>16</sub>	FF <sub>16</sub>

(1/2)



## 3.6 Mask ROM ordering method

GZZ-SH07-66B<36A0>

Mask ROM number	
-----------------	--

**740 FAMILY MASK ROM CONFIRMATION FORM  
SINGLE-CHIP MICROCOMPUTER M38067MCAXXFP/GP  
MITSUBISHI ELECTRIC**

Receipt	Date:	
	Section head signature	Supervisor signature

Note : Please fill in all items marked \*.

* Customer	Company name	TEL (      )	Issuance signature	Submitted by	Supervisor
	Date issued	Date:			

\* 1. Confirmation

Specify the name of the product being ordered and the type of EPROMs submitted.

Three EPROMs are required for each pattern.

If at least two of the three sets of EPROMs submitted contain identical data, we will produce masks based on this data. We shall assume the responsibility for errors only if the mask ROM data on the products we produce differs from this data. Thus, extreme care must be taken to verify the data in the submitted EPROMs.

Microcomputer name :     M38067MCAXXFP                       M38067MCAXXGP

Checksum code for entire EPROM    

--	--	--	--

 (hexadecimal notation)

EPROM type (indicate the type used)

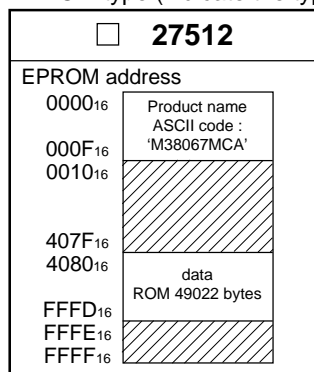

In the address space of the microcomputer, the internal ROM area is from address 4080<sub>16</sub> to FFFD<sub>16</sub>. The reset vector is stored in addresses FFFC<sub>16</sub> and FFFD<sub>16</sub>.

- (1) Set the data in the unused area (the shaded area of the diagram) to "FF<sub>16</sub>".
- (2) The ASCII codes of the product name "M38067MCA" must be entered in addresses 0000<sub>16</sub> to 0008<sub>16</sub>. And set the data "FF<sub>16</sub>" in addresses 0009<sub>16</sub> to 000F<sub>16</sub>. The ASCII codes and addresses are listed to the right in hexadecimal notation.

Address	'M' = 4D <sub>16</sub>	Address	'A' = 41 <sub>16</sub>
0000 <sub>16</sub>		0008 <sub>16</sub>	FF <sub>16</sub>
0001 <sub>16</sub>	'3' = 33 <sub>16</sub>	0009 <sub>16</sub>	FF <sub>16</sub>
0002 <sub>16</sub>	'8' = 38 <sub>16</sub>	000A <sub>16</sub>	FF <sub>16</sub>
0003 <sub>16</sub>	'0' = 30 <sub>16</sub>	000B <sub>16</sub>	FF <sub>16</sub>
0004 <sub>16</sub>	'6' = 36 <sub>16</sub>	000C <sub>16</sub>	FF <sub>16</sub>
0005 <sub>16</sub>	'7' = 37 <sub>16</sub>	000D <sub>16</sub>	FF <sub>16</sub>
0006 <sub>16</sub>	'M' = 4D <sub>16</sub>	000E <sub>16</sub>	FF <sub>16</sub>
0007 <sub>16</sub>	'C' = 43 <sub>16</sub>	000F <sub>16</sub>	FF <sub>16</sub>





## 3.6 Mask ROM ordering method

GZZ-SH07-54B<35A0>

Mask ROM number	
-----------------	--

**740 FAMILY MASK ROM CONFIRMATION FORM  
SINGLE-CHIP MICROCOMPUTER M38067MCDXXXFP  
MITSUBISHI ELECTRIC**

Receipt	Date:	
	Section head signature	Supervisor signature

Note : Please fill in all items marked \*.

* Customer	Company name	TEL (      )	Issuance signature	Submitted by	Supervisor
	Date issued	Date:			

\* 1. Confirmation

Specify the type of EPROMs submitted.

Three EPROMs are required for each pattern.

If at least two of the three sets of EPROMs submitted contain identical data, we will produce masks based on this data. We shall assume the responsibility for errors only if the mask ROM data on the products we produce differs from this data. Thus, extreme care must be taken to verify the data in the submitted EPROMs.

Checksum code for entire EPROM

--	--	--	--

(hexadecimal notation)

EPROM type (indicate the type used)

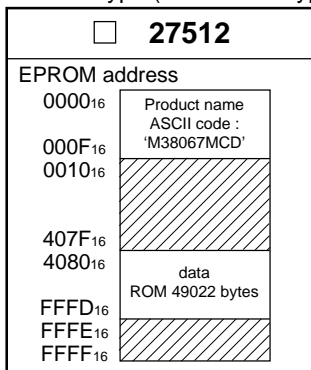

In the address space of the microcomputer, the internal ROM area is from address 4080<sub>16</sub> to FFFD<sub>16</sub>. The reset vector is stored in addresses FFFC<sub>16</sub> and FFFD<sub>16</sub>.

- (1) Set the data in the unused area (the shaded area of the diagram) to "FF<sub>16</sub>".
- (2) The ASCII codes of the product name "M38067MCD" must be entered in addresses 0000<sub>16</sub> to 0008<sub>16</sub>. And set the data "FF<sub>16</sub>" in addresses 0009<sub>16</sub> to 000F<sub>16</sub>. The ASCII codes and addresses are listed to the right in hexadecimal notation.

Address

0000 <sub>16</sub>	'M' = 4D <sub>16</sub>
0001 <sub>16</sub>	'3' = 33 <sub>16</sub>
0002 <sub>16</sub>	'8' = 38 <sub>16</sub>
0003 <sub>16</sub>	'0' = 30 <sub>16</sub>
0004 <sub>16</sub>	'6' = 36 <sub>16</sub>
0005 <sub>16</sub>	'7' = 37 <sub>16</sub>
0006 <sub>16</sub>	'M' = 4D <sub>16</sub>
0007 <sub>16</sub>	'C' = 43 <sub>16</sub>

Address

0008 <sub>16</sub>	'D' = 44 <sub>16</sub>
0009 <sub>16</sub>	FF <sub>16</sub>
000A <sub>16</sub>	FF <sub>16</sub>
000B <sub>16</sub>	FF <sub>16</sub>
000C <sub>16</sub>	FF <sub>16</sub>
000D <sub>16</sub>	FF <sub>16</sub>
000E <sub>16</sub>	FF <sub>16</sub>
000F <sub>16</sub>	FF <sub>16</sub>



### 3.7 Mark specification form

#### 80P6N (80-PIN QFP) MARK SPECIFICATION FORM

Mitsubishi IC catalog name

Please choose one of the marking types below (A, B, C), and enter the Mitsubishi IC catalog name and the special mark (if needed).

#### A. Standard Mitsubishi Mark

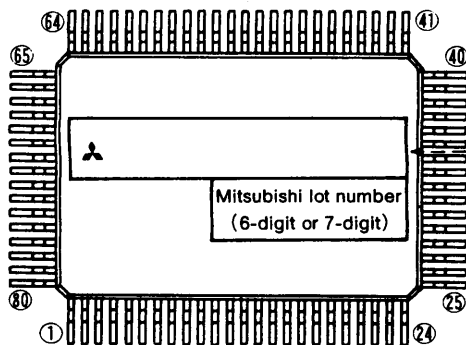

Mitsubishi IC catalog name

#### B. Customer's Parts Number + Mitsubishi Catalog Name

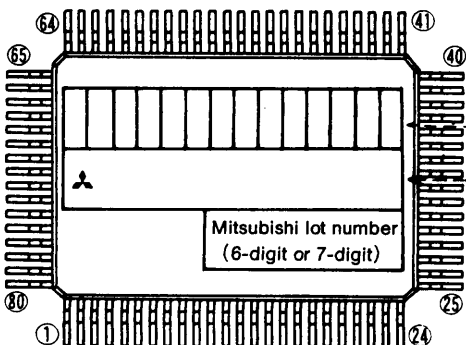

Customer's parts number

Note: The fonts and size of characters are standard Mitsubishi type.

Mitsubishi IC catalog name

Note3: Customer's parts number can be up to 14 characters:

Only 0~9, A~Z, +, -, /, (, ), &, ©, . (period), and , (comma) are usable.

4: If the Mitsubishi logo is not required, check the box below.

Mitsubishi logo is not required

Note1: The mark field should be written right aligned.

2: The fonts and size of characters are standard Mitsubishi type.

#### C. Special Mark Required

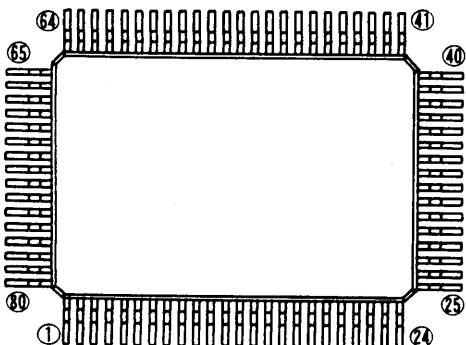

Note1: If the special mark is to be printed, indicate the desired layout of the mark in the left figure. The layout will be duplicated as close as possible. Mitsubishi lot number (6-digit or 7-digit) and mask ROM number (3-digit) are always marked.

2: If the customer's trade mark logo must be used in the special mark, check the box below. Please submit a clean original of the logo. For the new special character fonts a clean font original (ideally logo drawing) must be submitted.

Special logo required

The standard Mitsubishi font is used for all characters except for a logo.

# APPENDIX

## 3.7 Mark specification form

### 80P6S (80-PIN QFP) MARK SPECIFICATION FORM 80P6D (80-PIN Fine-pitch QFP)

Mitsubishi IC catalog name

Please choose one of the marking types below (A, B, C), and enter the Mitsubishi IC catalog name and the special mark (if needed).

#### A. Standard Mitsubishi Mark

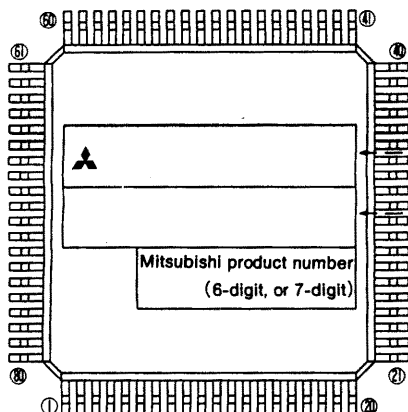

Mitsubishi IC catalog name

Mitsubishi IC catalog name

Mitsubishi product number  
(6-digit, or 7-digit)

#### B. Customer's Parts Number + Mitsubishi IC Catalog Name

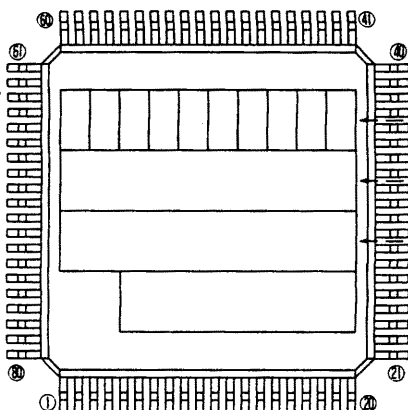

Customer's Parts Number

Note : The fonts and size of characters are standard Mitsubishi type.

Mitsubishi IC catalog name

Note1 : The mark field should be written right aligned.

2: The fonts and size of characters are standard Mitsubishi type.

3: Customer's parts number can be up to 10 alphanumeric characters for capital letters, hyphens, commas, periods and so on.

4: If the Mitsubishi logo  is not required, check the box below.

Mitsubishi logo is not required

5: The allocation of Mitsubishi IC catalog name and Mitsubishi product number is different on the package owing to the number of Mitsubishi IC catalog name's characters, and the requiring Mitsubishi logo  or not.

#### C. Special Mark Required

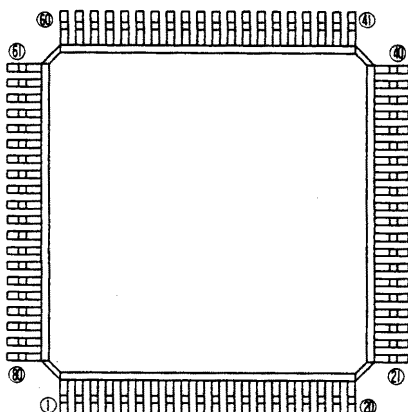

Note1 : If special mark is to be printed, indicate the desired layout of the mark in the left figure. The layout will be duplicated technically as close as possible. Mitsubishi product number (6-digit, or 7-digit) and Mask ROM number (3-digit) are always marked for sorting the products.

2: If special character fonts (e.g., customer's trade mark logo) must be used in Special Mark, check the box below.

For the new special character fonts a clean font original (ideally logo drawing) must be submitted.

Special character fonts required

### 3.8 Package outline

#### 80P6N-A

Plastic 80pin 14x20mm body QFP

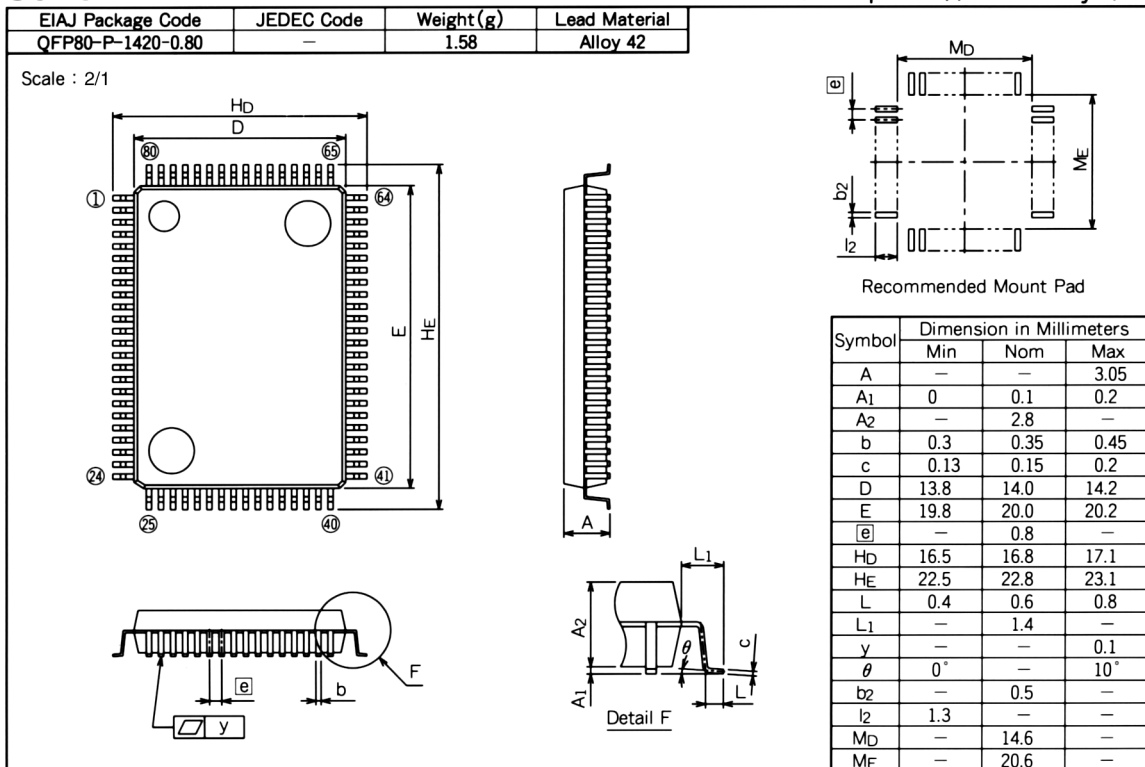

#### 80P6S-A

Plastic 80pin 14x14mm body QFP

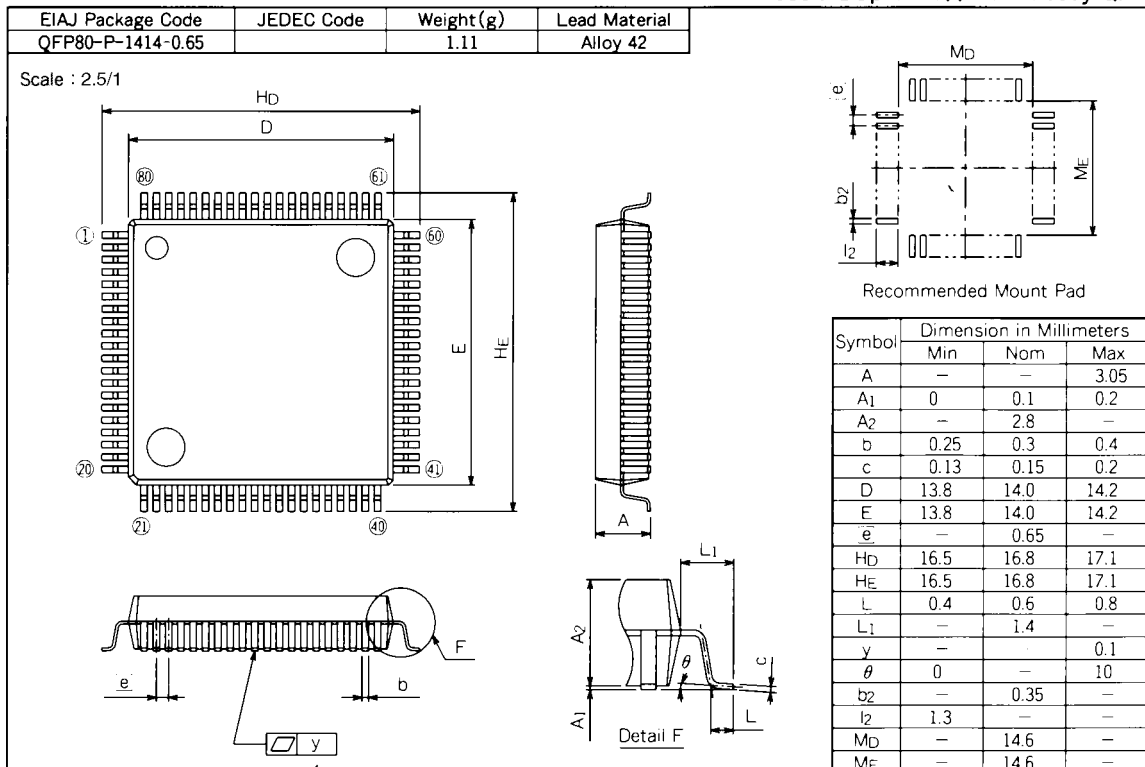

# APPENDIX

## 3.8 Package outline

### 80D0

Glass seal 80pin QFN

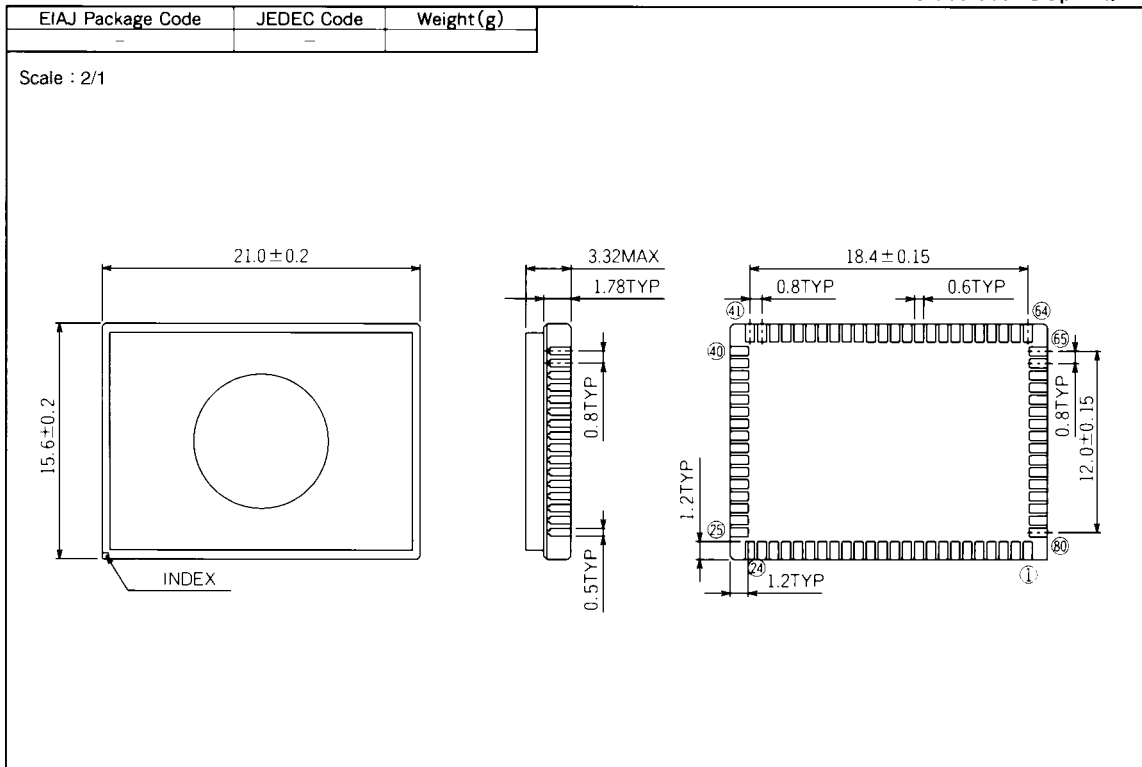

### 80P6D-A

Plastic 80pin 12X12mm body LQFP

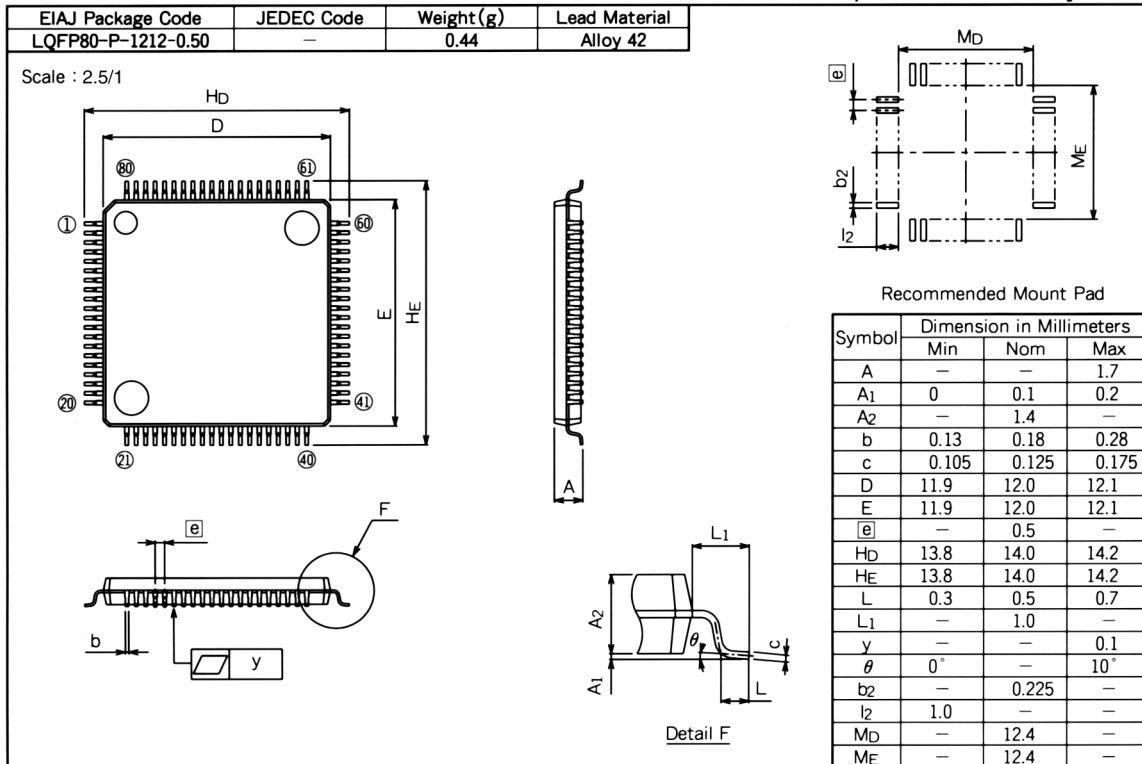

## 3.9 List of instruction codes

### 3.9 List of instruction codes

D7 – D4	D3 – D0	Hexadecimal notation															
		0000	0001	0010	0011	0100	0101	0110	0111	1000	1001	1010	1011	1100	1101	1110	1111
		0	1	2	3	4	5	6	7	8	9	A	B	C	D	E	F
0000	0	BRK	ORA IND, X	JSR ZP, IND	BBS 0, A	—	ORA ZP	ASL ZP	BBS 0, ZP	PHP	ORA IMM	ASL A	SEB 0, A	—	ORA ABS	ASL ABS	SEB 0, ZP
0001	1	BPL	ORA IND, Y	CLT	BBC 0, A	—	ORA ZP, X	ASL ZP, X	BBC 0, ZP	CLC	ORA ABS, Y	DEC A	CLB 0, A	—	ORA ABS, X	ASL ABS, X	CLB 0, ZP
0010	2	JSR ABS	AND IND, X	JSR SP	BBS 1, A	BIT ZP	AND ZP	ROL ZP	BBS 1, ZP	PLP	AND IMM	ROL A	SEB 1, A	BIT ABS	AND ABS	ROL ABS	SEB 1, ZP
0011	3	BMI	AND IND, Y	SET	BBC 1, A	—	AND ZP, X	ROL ZP, X	BBC 1, ZP	SEC	AND ABS, Y	INC A	CLB 1, A	LDM ZP	AND ABS, X	ROL ABS, X	CLB 1, ZP
0100	4	RTI	EOR IND, X	STP	BBS 2, A	COM ZP	EOR ZP	LSR ZP	BBS 2, ZP	PHA	EOR IMM	LSR A	SEB 2, A	JMP ABS	EOR ABS	LSR ABS	SEB 2, ZP
0101	5	BVC	EOR IND, Y	—	BBC 2, A	—	EOR ZP, X	LSR ZP, X	BBC 2, ZP	CLI	EOR ABS, Y	—	CLB 2, A	—	EOR ABS, X	LSR ABS, X	CLB 2, ZP
0110	6	RTS	ADC IND, X	MUL ZP, X	BBS 3, A	TST ZP	ADC ZP	ROR ZP	BBS 3, ZP	PLA	ADC IMM	ROR A	SEB 3, A	JMP IND	ADC ABS	ROR ABS	SEB 3, ZP
0111	7	BVS	ADC IND, Y	—	BBC 3, A	—	ADC ZP, X	ROR ZP, X	BBC 3, ZP	SEI	ADC ABS, Y	—	CLB 3, A	—	ADC ABS, X	ROR ABS, X	CLB 3, ZP
1000	8	BRA	STA IND, X	RRF ZP	BBS 4, A	STY ZP	STA ZP	STX ZP	BBS 4, ZP	DEY	—	TXA	SEB 4, A	STY ABS	STA ABS	STX ABS	SEB 4, ZP
1001	9	BCC	STA IND, Y	—	BBC 4, A	STY ZP, X	STA ZP, X	STX ZP, Y	BBC 4, ZP	TYA	STA ABS, Y	TXS	CLB 4, A	—	STA ABS, X	—	CLB 4, ZP
1010	A	LDY IMM	LDA IND, X	LDX IMM	BBS 5, A	LDY ZP	LDA ZP	LDX ZP	BBS 5, ZP	TAY	LDA IMM	TAX	SEB 5, A	LDY ABS	LDA ABS	LDX ABS	SEB 5, ZP
1011	B	BCS	LDA IND, Y	JMP ZP, IND	BBC 5, A	LDY ZP, X	LDA ZP, X	LDX ZP, Y	BBC 5, ZP	CLV	LDA ABS, Y	TSX	CLB 5, A	LDY ABS, X	LDA ABS, X	LDX ABS, Y	CLB 5, ZP
1100	C	CPY IMM	CMP IND, X	WIT	BBS 6, A	CPY ZP	CMP ZP	DEC ZP	BBS 6, ZP	INY	CMP IMM	DEX	SEB 6, A	CPY ABS	CMP ABS	DEC ABS	SEB 6, ZP
1101	D	BNE	CMP IND, Y	—	BBC 6, A	—	CMP ZP, X	DEC ZP, X	BBC 6, ZP	CLD	CMP ABS, Y	—	CLB 6, A	—	CMP ABS, X	DEC ABS, X	CLB 6, ZP
1110	E	CPX IMM	SBC IND, X	DIV ZP, X	BBS 7, A	CPX ZP	SBC ZP	INC ZP	BBS 7, ZP	INX	SBC IMM	NOP	SEB 7, A	CPX ABS	SBC ABS	INC ABS	SEB 7, ZP
1111	F	BEQ	SBC IND, Y	—	BBC 7, A	—	SBC ZP, X	INC ZP, X	BBC 7, ZP	SED	SBC ABS, Y	—	CLB 7, A	—	SBC ABS, X	INC ABS, X	CLB 7, ZP

- 3-byte instruction
- 2-byte instruction
- 1-byte instruction







# APPENDIX

## 3.10 Machine instructions

Symbol	Function	Details	Addressing mode																	
			IMP			IMM			A			BIT, A			ZP			BIT, ZP		
			OP	n	#	OP	n	#	OP	n	#	OP	n	#	OP	n	#	OP	n	#
BVC (Note 4)	$V = 0?$	Branches when the contents of overflow flag is "0".																		
BVS (Note 4)	$V = 1?$	Branches when the contents of overflow flag is "1".																		
CLB	$Ab \text{ or } Mb \leftarrow 0$	Clears the contents of the bit specified in the accumulator or memory to "0".										$1B$	2	1				$1F$	5	2
CLC	$C \leftarrow 0$	Clears the contents of the carry flag to "0".	18	2	1															
CLD	$D \leftarrow 0$	Clears the contents of decimal mode flag to "0".	D8	2	1															
CLI	$I \leftarrow 0$	Clears the contents of interrupt disable flag to "0".	58	2	1															
CLT	$T \leftarrow 0$	Clears the contents of index X mode flag to "0".	12	2	1															
CLV	$V \leftarrow 0$	Clears the contents of overflow flag to "0".	B8	2	1															
CMP (Note 3)	When $T = 0$ $A - M$ When $T = 1$ $M(X) - M$	Compares the contents of accumulator and memory. Compares the contents of the memory specified by the addressing mode with the contents of the address indicated by index register X.				C9	2	2									C5	3	2	
COM	$M \leftarrow \bar{M}$	Forms a one's complement of the contents of memory, and stores it into memory.														44	5	2		
CPX	$X - M$	Compares the contents of index register X and memory.				E0	2	2								E4	3	2		
CPY	$Y - M$	Compares the contents of index register Y and memory.				C0	2	2								C4	3	2		
DEC	$A \leftarrow A - 1$ or $M \leftarrow M - 1$	Decrements the contents of the accumulator or memory by 1.									1A	2	1			C6	5	2		
DEX	$X \leftarrow X - 1$	Decrements the contents of index register X by 1.	CA	2	1															
DEY	$Y \leftarrow Y - 1$	Decrements the contents of index register Y by 1.	88	2	1															
DIV	$A \leftarrow (M(zz + X + 1),$ $M(zz + X)) / A$ $M(S) \leftarrow 1$ 's complement of Remainder $S \leftarrow S - 1$	Divides the 16-bit data that is the contents of M (zz + x + 1) for high byte and the contents of M (zz + x) for low byte by the accumulator. Stores the quotient in the accumulator and the 1's complement of the remainder on the stack.																		
EOR (Note 1)	When $T = 0$ $A \leftarrow A \vee M$  When $T = 1$ $M(X) \leftarrow M(X) \vee M$	"Exclusive-ORs" the contents of accumulator and memory. The results are stored in the accumulator. "Exclusive-ORs" the contents of the memory specified by the addressing mode and the contents of the memory at the address indicated by index register X. The results are stored into the memory at the address indicated by index register X.				49	2	2								45	3	2		
INC	$A \leftarrow A + 1$ or $M \leftarrow M + 1$	Increments the contents of accumulator or memory by 1.									3A	2	1			E6	5	2		
INX	$X \leftarrow X + 1$	Increments the contents of index register X by 1.	E8	2	1															
INY	$Y \leftarrow Y + 1$	Increments the contents of index register Y by 1.	C8	2	1															



# APPENDIX

## 3.10 Machine instructions

Symbol	Function	Details	Addressing mode																	
			IMP			IMM			A			BIT, A			ZP			BIT, ZP		
			OP	n	#	OP	n	#	OP	n	#	OP	n	#	OP	n	#	OP	n	#
JMP	If addressing mode is ABS PCL ← ADL PCH ← ADH If addressing mode is IND PCL ← M (ADH, ADL) PCH ← M (ADH, ADL + 1) If addressing mode is ZP, IND PCL ← M(00, ADL) PCH ← M(00, ADL + 1)	Jumps to the specified address.																		
JSR	M(S) ← PCH S ← S - 1 M(S) ← PCL S ← S - 1 After executing the above, if addressing mode is ABS, PCL ← ADL PCH ← ADH if addressing mode is SP, PCL ← ADL PCH ← FF If addressing mode is ZP, IND, PCL ← M(00, ADL) PCH ← M(00, ADL + 1)	After storing contents of program counter in stack, and jumps to the specified address.																		
LDA (Note 2)	When T = 0 A ← M When T = 1 M(X) ← M	Load accumulator with contents of memory.  Load memory indicated by index register X with contents of memory specified by the addressing mode.				A9	2	2								A5	3	2		
LDM	M ← nn	Load memory with immediate value.													3C	4	3			
LDX	X ← M	Load index register X with contents of memory.				A2	2	2							A6	3	2			
LDY	Y ← M	Load index register Y with contents of memory.				A0	2	2							A4	3	2			
LSR	$\begin{matrix} 7 & 0 \\ 0 \rightarrow & \square \rightarrow C \end{matrix}$	Shift the contents of accumulator or memory to the right by one bit. The low order bit of accumulator or memory is stored in carry, 7th bit is cleared.							4A	2	1				46	5	2			
MUL	M(S) · A ← A X M(zz + X) S ← S - 1	Multiplies the accumulator with the contents of memory specified by the zero page X addressing mode and stores the high byte of the result on the stack and the low byte in the accumulator.																		
NOP	PC ← PC + 1	No operation.	EA	2	1															
ORA (Note 1)	When T = 0 A ← A V M  When T = 1 M(X) ← M(X) V M	"Logical OR's" the contents of memory and accumulator. The result is stored in the accumulator. "Logical OR's" the contents of memory indicated by index register X and contents of memory specified by the addressing mode. The result is stored in the memory specified by index register X.				09	2	2							05	3	2			



# APPENDIX

## 3.10 Machine instructions

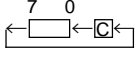
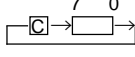
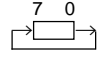
Symbol	Function	Details	Addressing mode																			
			IMP			IMM			A			BIT, A			ZP			BIT, ZP				
			OP	n	#	OP	n	#	OP	n	#	OP	n	#	OP	n	#	OP	n	#		
PHA	$M(S) \leftarrow A$ $S \leftarrow S - 1$	Saves the contents of the accumulator in memory at the address indicated by the stack pointer and decrements the contents of stack pointer by 1.	48	3	1																	
PHP	$M(S) \leftarrow PS$ $S \leftarrow S - 1$	Saves the contents of the processor status register in memory at the address indicated by the stack pointer and decrements the contents of the stack pointer by 1.	08	3	1																	
PLA	$S \leftarrow S + 1$ $A \leftarrow M(S)$	Increments the contents of the stack pointer by 1 and restores the accumulator from the memory at the address indicated by the stack pointer.	68	4	1																	
PLP	$S \leftarrow S + 1$ $PS \leftarrow M(S)$	Increments the contents of stack pointer by 1 and restores the processor status register from the memory at the address indicated by the stack pointer.	28	4	1																	
ROL		Shifts the contents of the memory or accumulator to the left by one bit. The high order bit is shifted into the carry flag and the carry flag is shifted into the low order bit.							2A	2	1					26	5	2				
ROR		Shifts the contents of the memory or accumulator to the right by one bit. The low order bit is shifted into the carry flag and the carry flag is shifted into the high order bit.							6A	2	1					66	5	2				
RRF		Rotates the contents of memory to the right by 4 bits.														82	8	2				
RTI	$S \leftarrow S + 1$ $PS \leftarrow M(S)$ $S \leftarrow S + 1$ $PCL \leftarrow M(S)$ $S \leftarrow S + 1$ $PCH \leftarrow M(S)$	Returns from an interrupt routine to the main routine.	40	6	1																	
RTS	$S \leftarrow S + 1$ $PCL \leftarrow M(S)$ $S \leftarrow S + 1$ $PCH \leftarrow M(S)$	Returns from a subroutine to the main routine.	60	6	1																	
SBC (Note 1) (Note 5)	When $T = 0$ $A \leftarrow A - M - \bar{C}$  When $T = 1$ $M(X) \leftarrow M(X) - M - \bar{C}$	Subtracts the contents of memory and complement of carry flag from the contents of accumulator. The results are stored into the accumulator. Subtracts contents of complement of carry flag and contents of the memory indicated by the addressing mode from the memory at the address indicated by index register X. The results are stored into the memory of the address indicated by index register X.							E9	2	2					E5	3	2				
SEB	$Ab \text{ or } Mb \leftarrow 1$	Sets the specified bit in the accumulator or memory to "1".														0B 2i	2	1		0F 2i	5	2
SEC	$C \leftarrow 1$	Sets the contents of the carry flag to "1".	38	2	1																	
SED	$D \leftarrow 1$	Sets the contents of the decimal mode flag to "1".	F8	2	1																	
SEI	$I \leftarrow 1$	Sets the contents of the interrupt disable flag to "1".	78	2	1																	
SET	$T \leftarrow 1$	Sets the contents of the index X mode flag to "1".	32	2	1																	





# APPENDIX

## 3.10 Machine instructions

Symbol	Function	Details	Addressing mode																		
			IMP			IMM			A			BIT, A			ZP			BIT, ZP			
			OP	n	#	OP	n	#	OP	n	#	OP	n	#	OP	n	#	OP	n	#	
STA	$M \leftarrow A$	Stores the contents of accumulator in memory.														85	4	2			
STP		Stops the oscillator.	42	2	1																
STX	$M \leftarrow X$	Stores the contents of index register X in memory.														86	4	2			
STY	$M \leftarrow Y$	Stores the contents of index register Y in memory.														84	4	2			
TAX	$X \leftarrow A$	Transfers the contents of the accumulator to index register X.	AA	2	1																
TAY	$Y \leftarrow A$	Transfers the contents of the accumulator to index register Y.	A8	2	1																
TST	$M = 0?$	Tests whether the contents of memory are "0" or not.														64	3	2			
TSX	$X \leftarrow S$	Transfers the contents of the stack pointer to index register X.	BA	2	1																
TXA	$A \leftarrow X$	Transfers the contents of index register X to the accumulator.	8A	2	1																
TXS	$S \leftarrow X$	Transfers the contents of index register X to the stack pointer.	9A	2	1																
TYA	$A \leftarrow Y$	Transfers the contents of index register Y to the accumulator.	98	2	1																
WIT		Stops the internal clock.	C2	2	1																

- Notes**
- 1 : The number of cycles "n" is increased by 3 when T is 1.
  - 2 : The number of cycles "n" is increased by 2 when T is 1.
  - 3 : The number of cycles "n" is increased by 1 when T is 1.
  - 4 : The number of cycles "n" is increased by 2 when branching has occurred.
  - 5 : N, V, and Z flags are invalid in decimal operation mode.



# APPENDIX

## 3.11 SFR memory map

---

### 3.11 SFR memory map

0000 <sub>16</sub>	Port P0 (P0)	0020 <sub>16</sub>	Prescaler 12 (PRE12)
0001 <sub>16</sub>	Port P0 direction register (P0D)	0021 <sub>16</sub>	Timer 1 (T1)
0002 <sub>16</sub>	Port P1 (P1)	0022 <sub>16</sub>	Timer 2 (T2)
0003 <sub>16</sub>	Port P1 direction register (P1D)	0023 <sub>16</sub>	Timer XY mode register (TM)
0004 <sub>16</sub>	Port P2 (P2)	0024 <sub>16</sub>	Prescaler X (PREX)
0005 <sub>16</sub>	Port P2 direction register (P2D)	0025 <sub>16</sub>	Timer X (TX)
0006 <sub>16</sub>	Port P3 (P3)	0026 <sub>16</sub>	Prescaler Y (PREY)
0007 <sub>16</sub>	Port P3 direction register (P3D)	0027 <sub>16</sub>	Timer Y (TY)
0008 <sub>16</sub>	Port P4 (P4)	0028 <sub>16</sub>	
0009 <sub>16</sub>	Port P4 direction register (P4D)	0029 <sub>16</sub>	
000A <sub>16</sub>	Port P5 (P5)	002A <sub>16</sub>	
000B <sub>16</sub>	Port P5 direction register (P5D)	002B <sub>16</sub>	
000C <sub>16</sub>	Port P6 (P6)	002C <sub>16</sub>	
000D <sub>16</sub>	Port P6 direction register (P6D)	002D <sub>16</sub>	
000E <sub>16</sub>	Port P7 (P7)	002E <sub>16</sub>	
000F <sub>16</sub>	Port P7 direction register (P7D)	002F <sub>16</sub>	
0010 <sub>16</sub>	Port P8 (P8)	0030 <sub>16</sub>	
0011 <sub>16</sub>	Port P8 direction register (P8D)	0031 <sub>16</sub>	
0012 <sub>16</sub>		0032 <sub>16</sub>	
0013 <sub>16</sub>		0033 <sub>16</sub>	
0014 <sub>16</sub>		0034 <sub>16</sub>	AD/DA control register (ADCON)
0015 <sub>16</sub>		0035 <sub>16</sub>	A-D conversion register (AD)
0016 <sub>16</sub>		0036 <sub>16</sub>	D-A1 conversion register (DA1)
0017 <sub>16</sub>		0037 <sub>16</sub>	D-A2 conversion register (DA2)
0018 <sub>16</sub>	Transmit/Receive buffer register (TB/RB)	0038 <sub>16</sub>	
0019 <sub>16</sub>	Serial I/O1 status register (SIO1STS)	0039 <sub>16</sub>	
001A <sub>16</sub>	Serial I/O1 control register (SIO1CON)	003A <sub>16</sub>	Interrupt edge selection register (INTEDGE)
001B <sub>16</sub>	UART control register (UARTCON)	003B <sub>16</sub>	CPU mode register (CPUM)
001C <sub>16</sub>	Baud rate generator (BRG)	003C <sub>16</sub>	Interrupt request register 1 (IREQ1)
001D <sub>16</sub>	Serial I/O2 control register (SIO2CON)	003D <sub>16</sub>	Interrupt request register 2 (IREQ2)
001E <sub>16</sub>		003E <sub>16</sub>	Interrupt control register 1 (ICON1)
001F <sub>16</sub>	Serial I/O2 register (SIO2)	003F <sub>16</sub>	Interrupt control register 2 (ICON2)

### 3.12 Pin configuration

#### PIN CONFIGURATION (TOP VIEW)

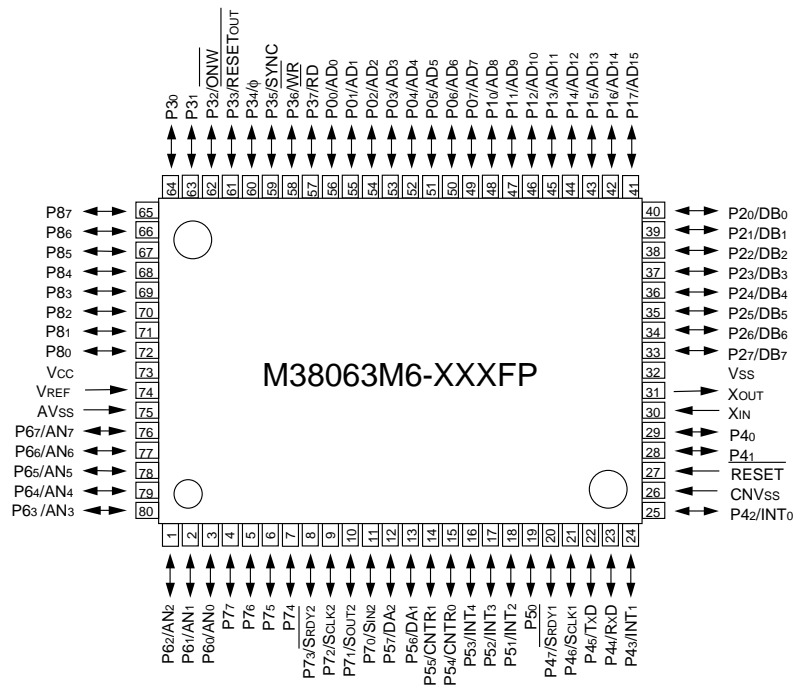

Package type : 80P6N-A  
80-pin plastic-molded QFP

# APPENDIX

## 3.12 Pin configuration

### PIN CONFIGURATION (TOP VIEW)

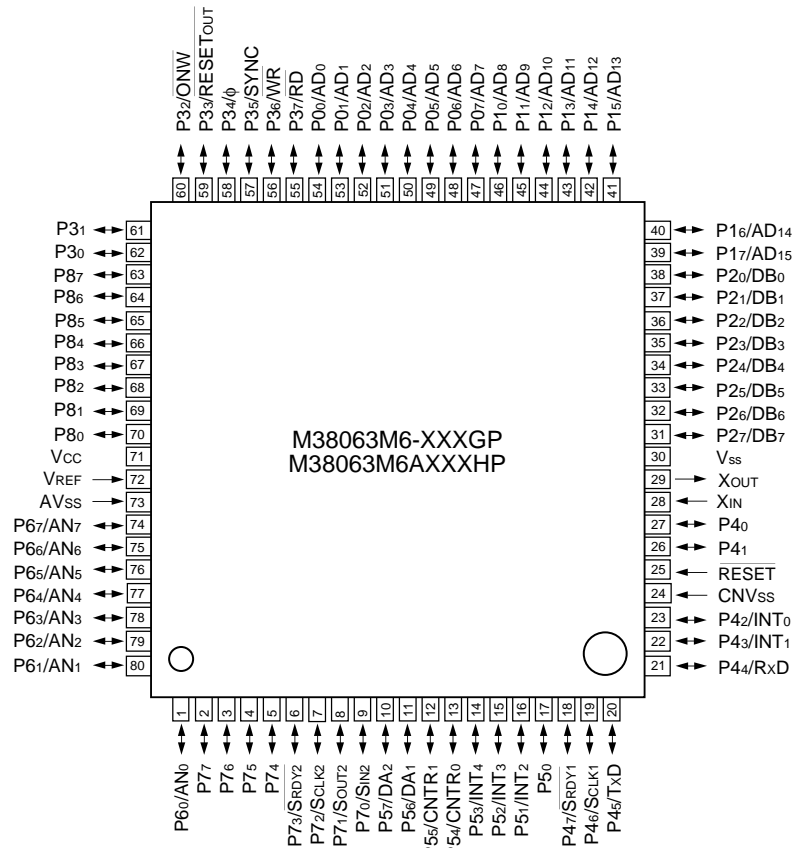

**Package type : 80P6S-A/80P6D-A**  
**80-pin plastic-molded QFP**

**MITSUBISHI SEMICONDUCTORS  
USER'S MANUAL  
3806Group**

---

Mar. First Edition 1996

Edited by  
Committee of editing of Mitsubishi Semiconductor USER'S MANUAL

Published by  
Mitsubishi Electric Corp., Semiconductor Marketing Division

---

This book, or parts thereof, may not be reproduced in any form without permission of Mitsubishi Electric Corporation.

©1996 **MITSUBISHI ELECTRIC CORPORATION**

User's Manual  
3806 Group

**Renesas Technology Corp.**  
Nippon Bldg.,6-2,Otemachi 2-chome,Chiyoda-ku,Tokyo,100-0004 Japan