

# Hybrid Stepper Motor

## 39BYG Series

Without Pulse-Torque Characteristics

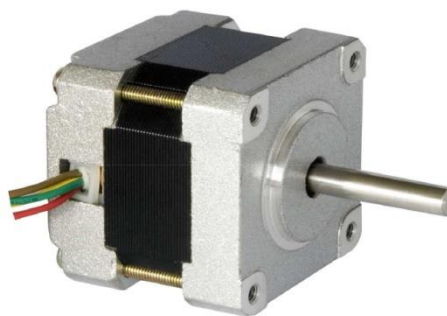

### General Specifications

Step Accuracy	± 5%
Temperature Rise	80°C Max
Ambient Temperature Range	-20°C ~ +50°C
Insulation Resistance	100 MΩ Min. 500 VDC
Dielectric Strength	500 VAC 1 minute

**Customized solutions on request.**



### Electrical Specifications

Model	Step Angle °	Motor Length L (mm)	Rate Voltage V	Rate Current A	Phase Resistance Ω	Phase Inductance mH	Holding Torque mNm	Detent Torque mNm	Rotor Inertia gcm <sup>2</sup>	Lead Wire NO.	Motor Weight kg
39BYG003-03	1.8	20	12	0.48	25	26	98.1	4.9	11	4	0.12
39BYG013	1.8	20	2.72	0.4	6.8	6.5	54.0	4.9	11	4	0.12
39BYG104-01	1.8	26	6.3	0.42	15	7.3	86.3	6.9	13	6	0.14
39BYG301	1.8	31	4.5	0.5	9.0	4.0	98.1	9.8	18	6	0.16
39BYG215	1.8	34	12	0.4	30	34	206.0	11.8	20	4	0.18
39BYG221	1.8	34	5.0	1.0	5.0	3.0	176.5	11.8	20	4	0.18
39BYG404-13	1.8	38	6.0	0.8	7.5	7.0	196.1	17.7	24	6	0.2
39BYG408-02	1.8	38	13	0.5	26	30	176.5	17.7	24	4	0.2
39BYG601	1.8	45	12	0.3	40	60	274.6	24.5	40	4	0.25

### Mechanical Dimensions

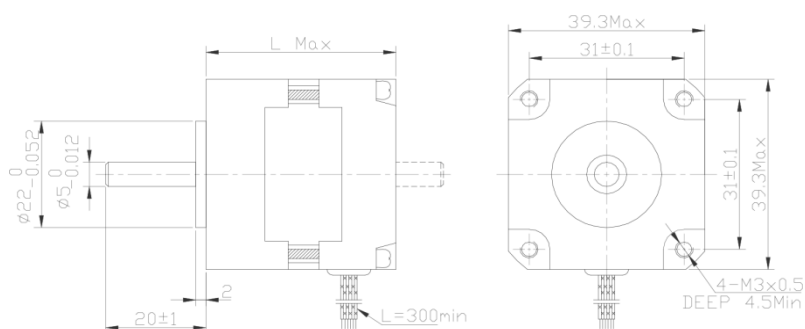

### Wiring Diagram

