

Space-saving Plug-in Signal Conditioners H-UNIT

P/I TRANSDUCER

Functions & Features

- Converting a standard pneumatic signal into a proportional DC output
- High-density mounting

Typical Applications

- Converting a pneumatic system into a 4 - 20 mA for indicating and controlling in DCS system

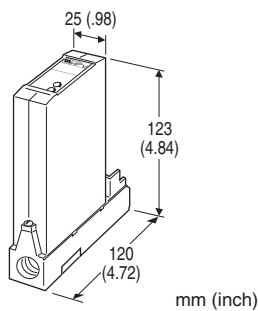

MODEL: HPV-[1]-R[2]

ORDERING INFORMATION

- Code number: HPV-[1]-R[2]
- Specify a code from below for each of [1] and [2].
(e.g. HPV-A-R/A2S/P7)
- Special output range (For codes Z & 0)

[1] OUTPUT

Current

- A: 4 - 20 mA DC (Load resistance 750 Ω max.)
- B: 2 - 10 mA DC (Load resistance 1500 Ω max.)
- C: 1 - 5 mA DC (Load resistance 3000 Ω max.)
- D: 0 - 20 mA DC (Load resistance 750 Ω max.)
- E: 0 - 16 mA DC (Load resistance 900 Ω max.)
- F: 0 - 10 mA DC (Load resistance 1500 Ω max.)
- G: 0 - 1 mA DC (Load resistance 15 kΩ max.)
- Z: Specify current (See OUTPUT SPECIFICATIONS)

Voltage

- 1: 0 - 10 mV DC (Load resistance 10 kΩ min.)
- 2: 0 - 100 mV DC (Load resistance 100 kΩ min.)
- 3: 0 - 1 V DC (Load resistance 1000 Ω min.)
- 4: 0 - 10 V DC (Load resistance 10 kΩ min.)
- 5: 0 - 5 V DC (Load resistance 5000 Ω min.)
- 6: 1 - 5 V DC (Load resistance 5000 Ω min.)
- 0: Specify voltage (See OUTPUT SPECIFICATIONS)

POWER INPUT

DC Power

R: 24 V DC

(Operational voltage range 24 V ±10 %, ripple 10 %p-p max.)

[2] OPTIONS (multiple selections)

Input

blank: 0.2 - 1.0 kgf/cm²

/A1S: 19.6 - 98.1 kPa

/A2S: 20 - 100 kPa

/A3S: 20.7 - 103.4 kPa

/A2: 0.2 - 1.0 bar

/A3: 3 - 15 psig

Pneumatic Connection

blank: Rc 1/4"

/P7: 1/4" NPT fitting

GENERAL SPECIFICATIONS

Construction: Plug-in

Connection

Output & power input: M3.5 screw terminals;
torque 0.8 N·m

Pneumatic: Rc 1/4" or 1/4" NPT female; torque ≤ 12 N·m

Material

Housing: Flame-resistant resin (black)

Base socket: Die cast aluminium

Screw terminals: Nickel-plated steel

Isolation: Output to power

Zero adjustment: -5 to +5 % (front)

Span adjustment: 95 to 105 % (front)

INPUT SPECIFICATIONS

Input

19.6 - 98.1 kPa, 0.2 - 1.0 kgf/cm²

20 - 100 kPa, 0.2 - 1.0 bar

20.7 - 103.4 kPa, 3 - 15 psig

OUTPUT SPECIFICATIONS

■ DC Current: 0 - 20 mA DC

Minimum span: 1 mA

Offset: Max. 1.5 times span

Load resistance: Output drive 15 V max.

■ DC Voltage: 0 - 12 V DC

Minimum span: 5 mV

Offset: Max. 1.5 times span

Load resistance: Output drive 1 mA max.; at ≥ 1 V

INSTALLATION

Current consumption: Approx. 60 mA

Operating temperature: -5 to +55°C (23 to 131°F)

Operating humidity: 30 to 90 %RH (non-condensing)
Mounting: Surface; Standard Rack Mounting Frame (BX-16H) available
Weight: 400 g (0.88 lb)

PERFORMANCE in percentage of span

Accuracy: $\pm 0.2\%$
Temp. coefficient: $\pm 0.03\%/^{\circ}\text{C}$ ($\pm 0.02\%/^{\circ}\text{F}$)
Response time: ≤ 0.5 sec. (0 - 90 %)
Permissible overrange: 196 kPa (2.0 kgf/cm², 1.96 bar, 28 psig)
Line voltage effect: $\pm 0.1\%$ over voltage range
Insulation resistance: $\geq 100\text{ M}\Omega$ with 500 V DC
Dielectric strength: 1500V AC @ 1 minute
 (output to power to housing)

EXTERNAL DIMENSIONS & TERMINAL ASSIGNMENTS unit: mm (inch)

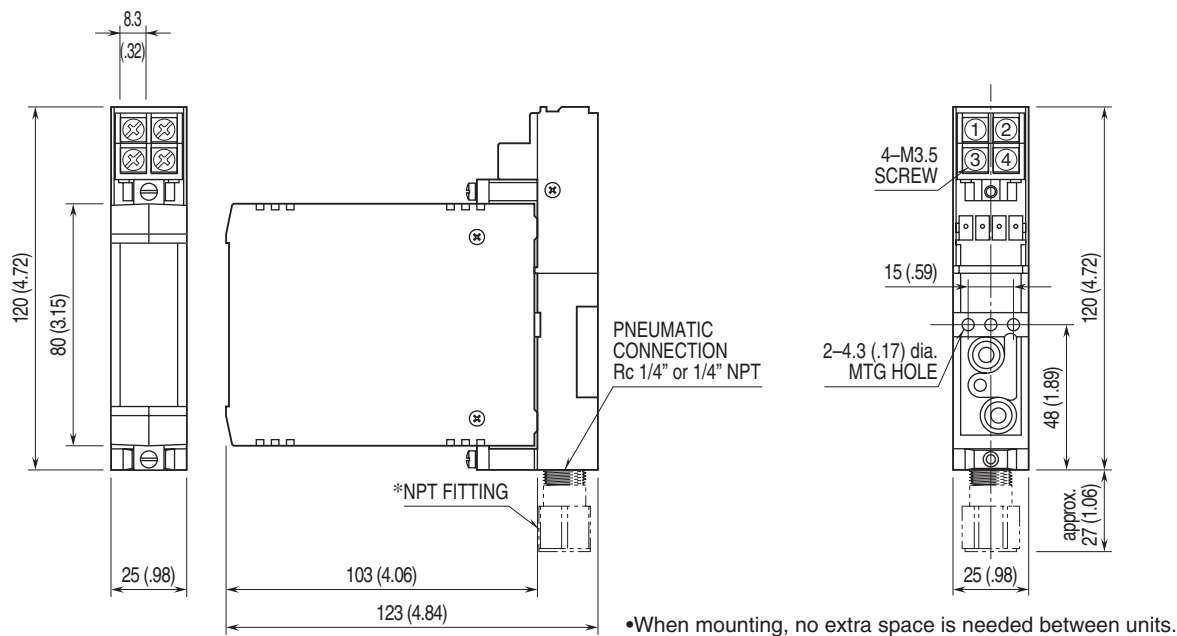

*Fitting provided for 1/4" NPT connection.

SCHEMATIC CIRCUITRY & CONNECTION DIAGRAM

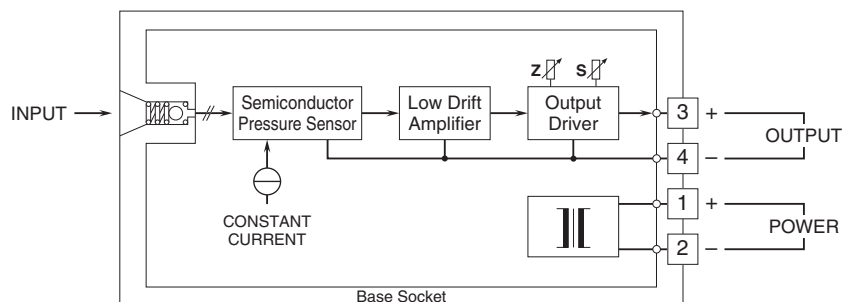



Specifications are subject to change without notice.