



144-Mbit DDR-II SIO SRAM Two-Word Burst Architecture

Features

- 144-Mbit density (8 M × 18)
- 333 MHz clock for high bandwidth
- Two-word burst for reducing address bus frequency
- Double Data Rate (DDR) interfaces (data transferred at 666 MHz) at 333 MHz
- Two input clocks (K and \bar{K}) for precise DDR timing
 - SRAM uses rising edges only
- Two input clocks for output data (C and \bar{C}) to minimize clock skew and flight time mismatches
- Echo clocks (CQ and \bar{CQ}) simplify data capture in high speed systems
- Synchronous internally self timed writes
- DDR-II operates with 1.5 cycle read latency when $\overline{\text{DOFF}}$ is asserted HIGH
- Operates similar to DDR-I device with 1 cycle read latency when $\overline{\text{DOFF}}$ is asserted LOW
- 1.8 V core power supply with HSTL inputs and outputs
- Variable drive HSTL output buffers
- Expanded HSTL output voltage (1.4 V– V_{DD})
 - Supports both 1.5 V and 1.8 V I/O supply
- Available in 165-ball FBGA package (15 × 17 × 1.4 mm)
- Offered in Pb-free package
- JTAG 1149.1 compatible test access port
- Phase Locked Loop (PLL) for accurate data placement

Configuration

CY7C1623KV18 – 8 M × 18

Functional Description

The CY7C1623KV18 is 1.8 V Synchronous Pipelined SRAM, equipped with DDR-II SIO (Double Data Rate Separate I/O) architecture. The DDR-II SIO consists of two separate ports: the read port and the write port to access the memory array. The read port has data outputs to support read operations and the write port has data inputs to support write operations. The DDR-II SIO has separate data inputs and data outputs to completely eliminate the need to ‘turnaround’ the data bus required with common I/O devices. Access to each port is accomplished through a common address bus. Addresses for read and write are latched on alternate rising edges of the input (K) clock. Write data is registered on the rising edges of both K and \bar{K} . Read data is driven on the rising edges of C and \bar{C} if provided, or on the rising edge of K and \bar{K} if C/ \bar{C} are not provided. Each address location is associated with two 18-bit words that burst sequentially into or out of the device.

Asynchronous inputs include an output impedance matching input (ZQ). Synchronous data outputs are tightly matched to the two output echo clocks CQ/ \bar{CQ} , eliminating the need to capture data separately from each individual DDR-II SIO SRAM in the system design. Output data clocks (C/ \bar{C}) enable maximum system clocking and data synchronization flexibility.

All synchronous inputs pass through input registers controlled by the K or \bar{K} input clocks. All data outputs pass through output registers controlled by the C or \bar{C} (or K or \bar{K} in a single clock domain) input clocks. Writes are conducted with on-chip synchronous self-timed write circuitry.

Selection Guide

Description		333 MHz	250 MHz	Unit
Maximum Operating Frequency		333	250	MHz
Maximum Operating Current	× 18	650	560	mA

Logic Block Diagram – CY7C1623KV18

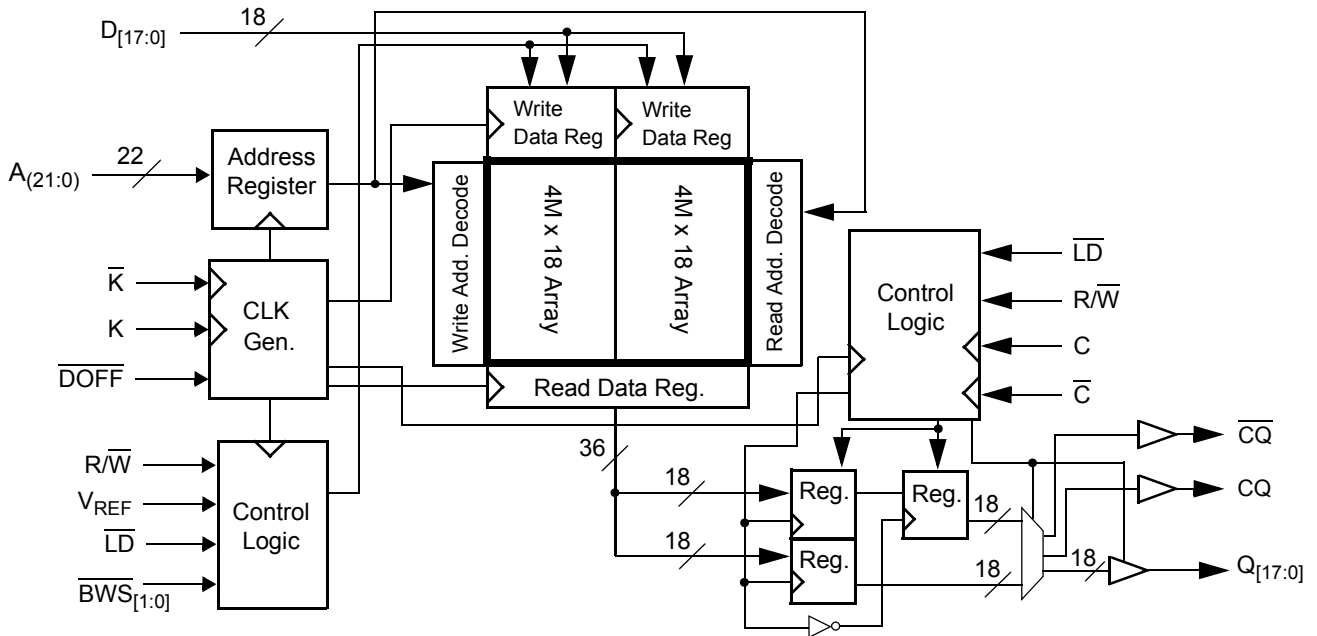

Contents

Pin Configurations	4	Scan Register Sizes	15
Pin Definitions	5	Instruction Codes	15
Functional Overview	6	Boundary Scan Order	16
Read Operations	6	Power Up Sequence in DDR-II SRAM	17
Write Operations	6	Power Up Sequence	17
Byte Write Operations	6	PLL Constraints	17
Single Clock Mode	6	Maximum Ratings	18
DDR Operation	7	Operating Range	18
Depth Expansion	7	Electrical Characteristics	18
Programmable Impedance	7	DC Electrical Characteristics	18
Echo Clocks	7	AC Electrical Characteristics	19
PLL	7	Capacitance	19
Application Example	7	Thermal Resistance	19
Truth Table	8	AC Test Loads and Waveforms	19
Write Cycle Descriptions	8	Switching Characteristics	20
IEEE 1149.1 Serial Boundary Scan (JTAG)	9	Switching Waveforms	22
Disabling the JTAG Feature	9	Ordering Information	23
Test Access Port	9	Ordering Code Definitions	23
Performing a TAP Reset	9	Package Diagram	24
TAP Registers	9	Acronyms	25
TAP Instruction Set	9	Document Conventions	25
TAP Controller State Diagram	11	Units of Measure	25
TAP Controller Block Diagram	12	Document History Page	26
TAP Electrical Characteristics	12	Sales, Solutions, and Legal Information	28
TAP AC Switching Characteristics	13	Worldwide Sales and Design Support	28
TAP Timing and Test Conditions	14	Products	28
Identification Register Definitions	15	PSoC Solutions	28

Pin Configurations

The pin configuration for CY7C1623KV18 follows: ^[1]

**Figure 1. 165-ball FBGA (15 × 17 × 1.4 mm) pinout
CY7C1623KV18 (8 M × 18)**

	1	2	3	4	5	6	7	8	9	10	11
A	CQ	A	A	R/W	BWS ₁	K	NC/288M	LD	A	A	CQ
B	NC	Q9	D9	A	NC	K	BWS ₀	A	NC	NC	Q8
C	NC	NC	D10	V _{SS}	A	A	A	V _{SS}	NC	Q7	D8
D	NC	D11	Q10	V _{SS}	V _{SS}	V _{SS}	V _{SS}	V _{SS}	NC	NC	D7
E	NC	NC	Q11	V _{DDQ}	V _{SS}	V _{SS}	V _{SS}	V _{DDQ}	NC	D6	Q6
F	NC	Q12	D12	V _{DDQ}	V _{DD}	V _{SS}	V _{DD}	V _{DDQ}	NC	NC	Q5
G	NC	D13	Q13	V _{DDQ}	V _{DD}	V _{SS}	V _{DD}	V _{DDQ}	NC	NC	D5
H	DOFF	V _{REF}	V _{DDQ}	V _{DDQ}	V _{DD}	V _{SS}	V _{DD}	V _{DDQ}	V _{DDQ}	V _{REF}	ZQ
J	NC	NC	D14	V _{DDQ}	V _{DD}	V _{SS}	V _{DD}	V _{DDQ}	NC	Q4	D4
K	NC	NC	Q14	V _{DDQ}	V _{DD}	V _{SS}	V _{DD}	V _{DDQ}	NC	D3	Q3
L	NC	Q15	D15	V _{DDQ}	V _{SS}	V _{SS}	V _{SS}	V _{DDQ}	NC	NC	Q2
M	NC	NC	D16	V _{SS}	V _{SS}	V _{SS}	V _{SS}	V _{SS}	NC	Q1	D2
N	NC	D17	Q16	V _{SS}	A	A	A	V _{SS}	NC	NC	D1
P	NC	NC	Q17	A	A	C	A	A	NC	D0	Q0
R	TDO	TCK	A	A	A	C	A	A	A	TMS	TDI

Note

1. NC/288M is not connected to the die and can be tied to any voltage level.

Pin Definitions

Pin Name	I/O	Pin Description
$D_{[17:0]}$	Input-Synchronous	Data Input Signals. Sampled on the rising edge of K and \bar{K} clocks during valid write operations.
\bar{LD}	Input-Synchronous	Synchronous Load. This input is brought LOW when a bus cycle sequence is defined. This definition includes address and read/write direction. All transactions operate on a burst of 2 data (one clock period of bus activity).
\overline{BWS}_0 , BWS_1	Input-Synchronous	Byte Write Select 0 and 1 – Active LOW. Sampled on the rising edge of the K and \bar{K} clocks during write operations. Used to select which byte is written into the device during the current portion of the write operations. Bytes not written remain unaltered. BWS_0 controls $D_{[8:0]}$, BWS_1 controls $D_{[17:9]}$. All the Byte Write Selects are sampled on the same edge as the data. Deselecting a Byte Write Select ignores the corresponding byte of data and it is not written into the device.
A	Input-Synchronous	Address Inputs. Sampled on the rising edge of the K clock during active read and write operations. These address inputs are multiplexed for both read and write operations. Internally, the device is organized as 8 M × 18 (2 arrays each of 4 M × 18). Therefore, only 22 address inputs are needed to access the entire memory array. These inputs are ignored when the appropriate port is deselected.
$Q_{[17:0]}$	Outputs-Synchronous	Data Output Signals. These pins drive out the requested data during a read operation. Valid data is driven out on the rising edge of both the C and \bar{C} clocks during read operations, or K and \bar{K} when in single clock mode. When the read port is deselected, $Q_{[17:0]}$ are automatically tri-stated.
R/\bar{W}	Input-Synchronous	Synchronous Read/Write Input. When \bar{LD} is LOW, this input designates the access type (read when R/\bar{W} is HIGH, write when R/\bar{W} is LOW) for the loaded address. R/\bar{W} must meet the setup and hold times around the edge of K.
C	Input Clock	Positive Input Clock for Output Data. C is used in conjunction with \bar{C} to clock out the read data from the device. C and \bar{C} can be used together to deskew the flight times of various devices on the board back to the controller. See Application Example on page 7 for further details.
\bar{C}	Input Clock	Negative Input Clock for Output Data. \bar{C} is used in conjunction with C to clock out the read data from the device. C and \bar{C} can be used together to deskew the flight times of various devices on the board back to the controller. See Application Example on page 7 for further details.
K	Input Clock	Positive Input Clock Input. The rising edge of K is used to capture synchronous inputs to the device and to drive out data through $Q_{[17:0]}$ when in single clock mode. All accesses are initiated on the rising edge of K.
\bar{K}	Input Clock	Negative Input Clock Input. \bar{K} is used to capture synchronous inputs being presented to the device and to drive out data through $Q_{[17:0]}$ when in single clock mode.
CQ	Echo Clock	CQ Referenced with Respect to C. This is a free-running clock and is synchronized to the input clock for output data (C) of the DDR-II. In the single clock mode, CQ is generated with respect to K. The timings for the echo clocks is shown in the Switching Characteristics on page 20 .
\bar{CQ}	Echo Clock	\bar{CQ} Referenced with Respect to \bar{C}. This is a free-running clock and is synchronized to the input clock for output data (\bar{C}) of the DDR-II. In the single clock mode, \bar{CQ} is generated with respect to K. The timings for the echo clocks is shown in the Switching Characteristics on page 20 .
ZQ	Input	Output Impedance Matching Input. This input is used to tune the device outputs to the system data bus impedance. CQ, \bar{CQ} , and $Q_{[17:0]}$ output impedance are set to $0.2 \times RQ$, where RQ is a resistor connected between ZQ and ground. Alternatively, this pin can be connected directly to V_{DDQ} , which enables the minimum impedance mode. This pin cannot be connected directly to GND or left unconnected.
\overline{DOFF}	Input	PLL Turn Off – Active LOW. Connecting this pin to ground turns off the PLL inside the device. The timing in the PLL turned off operation differs from those listed in this data sheet. For normal operation, this pin can be connected to a pull up through a 10-Kohm or less pull up resistor. The device behaves in DDR-I mode when the PLL is turned off. In this mode, the device can be operated at a frequency of up to 167 MHz with DDR-I timing.

Pin Definitions (continued)

Pin Name	I/O	Pin Description
TDO	Output	TDO Pin for JTAG.
TCK	Input	TCK Pin for JTAG.
TDI	Input	TDI Pin for JTAG.
TMS	Input	TMS Pin for JTAG.
NC	N/A	Not Connected to the Die. Can be tied to any voltage level.
NC/288M	N/A	Not Connected to the Die. Can be tied to any voltage level.
V _{REF}	Input-Reference	Reference Voltage Input. Static input used to set the reference level for HSTL inputs, Outputs, and AC measurement points.
V _{DD}	Power Supply	Power Supply Inputs to the Core of the Device.
V _{SS}	Ground	Ground for the Device.
V _{DDQ}	Power Supply	Power Supply Inputs for the Outputs of the Device.

Functional Overview

The CY7C1623KV18 is synchronous pipelined Burst SRAM equipped with a DDR-II Separate I/O interface, which operates with a read latency of one and half cycles when DOFF pin is tied HIGH. When DOFF pin is set LOW or connected to V_{SS} the device behaves in DDR-I mode with a read latency of one clock cycle.

Accesses are initiated on the rising edge of the positive input clock (K). All synchronous input timing is referenced from the rising edge of the input clocks (K and K) and all output timing is referenced to the rising edge of the output clocks (C/C, or K/K when in single clock mode).

All synchronous data inputs (D_[17:0]) pass through input registers controlled by the rising edge of the input clocks (K and K). All synchronous data outputs (Q_[17:0]) pass through output registers controlled by the rising edge of the output clocks (C/C, or K/K when in single-clock mode).

All synchronous control (R_W, LD, BWS_[0:1]) inputs pass through input registers controlled by the rising edge of the input clock (K).

Read Operations

The CY7C1623KV18 is organized internally as two arrays of 4 M × 18. Accesses are completed in a burst of two sequential 18-bit data words. Read operations are initiated by asserting R_W HIGH and LD LOW at the rising edge of the positive input clock (K). The address presented to address inputs is stored in the read address register. Following the next K clock rise the corresponding lowest order 18-bit word data is driven onto the Q_[17:0] using C as the output timing reference. On the subsequent rising edge of C, the next 18-bit data word is driven onto the Q_[17:0]. The requested data is valid 0.45 ns from the rising edge of the output clock (C or C, or K and K when in single clock mode). Read accesses can be initiated on every rising edge of the positive input clock (K). The data flow is pipelined such that data is transferred out of the device on every rising edge of the output clocks, C/C (or K/K when in single clock mode).

The CY7C1623KV18 first completes the pending read transactions, when read access is deselected. Synchronous internal circuitry automatically tri-states the output following the next rising edge of the positive output clock (C).

Write Operations

Write operations are initiated by asserting R_W LOW and LD LOW at the rising edge of the positive input clock (K). The address presented to address inputs is stored in the write address register. On the following K clock rise the data presented to D_[17:0] is latched and stored into the 18-bit write data register, provided BWS_[1:0] are both asserted active. On the subsequent rising edge of the negative input clock (K) the information presented to D_[17:0] is also stored into the write data register, provided BWS_[1:0] are both asserted active. The 36 bits of data are then written into the memory array at the specified location. Write accesses can be initiated on every rising edge of the positive input clock (K). The data flow is pipelined such that 18 bits of data can be transferred into the device on every rising edge of the input clocks (K and K).

When Write access is deselected, the device ignores all inputs after the pending write operations are completed.

Byte Write Operations

Byte write operations are supported by the CY7C1623KV18. A write operation is initiated as described in the [Write Operations](#) section. The bytes that are written are determined by BWS₀ and BWS₁, which are sampled with each set of 18-bit data words. Asserting the appropriate Byte Write Select input during the data portion of a write latches the data being presented and writes it into the device. Deasserting the Byte Write Select input during the data portion of a write enables the data stored in the device for that byte to remain unaltered. This feature can be used to simplify, read, modify, and write operations to a byte write operation.

Single Clock Mode

The CY7C1623KV18 can be used with a single clock that controls both the input and output registers. In this mode the device recognizes only a single pair of input clocks (K and K) that

control both the input and output registers. This operation is identical to the operation if the device had zero skew between the K/K and C/C clocks. All timing parameters remain the same in this mode. To use this mode of operation, tie C and \overline{C} HIGH at power on. This function is a strap option and not alterable during device operation.

DDR Operation

The CY7C1623KV18 enables high-performance operation through high clock frequencies (achieved through pipelining) and double data rate mode of operation.

If a read occurs after a write cycle, address and data for the write are stored in registers. The write information must be stored because the SRAM cannot perform the last word write to the array without conflicting with the read. The data stays in this register until the next write cycle occurs. On the first write cycle after the read(s), the stored data from the earlier write is written into the SRAM array. This is called a posted write.

Depth Expansion

Depth expansion requires replicating the \overline{LD} control signal for each bank. All other control signals can be common between banks as appropriate.

Programmable Impedance

An external resistor, RQ, must be connected between the ZQ pin on the SRAM and V_{SS} to enable the SRAM to adjust its output driver impedance. The value of RQ must be 5 times the value of the intended line impedance driven by the SRAM. The allowable

range of RQ to guarantee impedance matching with a tolerance of ± 15 percent is between 175Ω and 350Ω , with $V_{DDQ} = 1.5 V$. The output impedance is adjusted every 1024 cycles at power up to account for drifts in supply voltage and temperature.

Echo Clocks

Echo clocks are provided on the DDR-II to simplify data capture on high-speed systems. Two echo clocks are generated by the DDR-II. CQ is referenced with respect to C and \overline{CQ} is referenced with respect to \overline{C} . These are free-running clocks and are synchronized to the output clock of the DDR-II. In the single clock mode, CQ is generated with respect to K and \overline{CQ} is generated with respect to \overline{K} . The timing for the echo clocks is shown in [Switching Characteristics on page 20](#).

PLL

These chips use a Phase Locked Loop (PLL) that is designed to function between 120 MHz and the specified maximum clock frequency. During power up, when the \overline{DOFF} is tied HIGH, the PLL is locked after 20 μs of stable clock. The PLL is also reset by slowing or stopping the input clocks K and \overline{K} for a minimum of 30 ns. However, it is not necessary to reset the PLL to lock it to the desired frequency. The PLL automatically locks 20 μs after a stable clock is presented. The PLL may be disabled by applying ground to the \overline{DOFF} pin. When the PLL is turned off, the device behaves in DDR-I mode (with one cycle latency and a longer access time).

Application Example

Figure 2 shows four DDR-II SIO used in an application.

Figure 2. Application Example

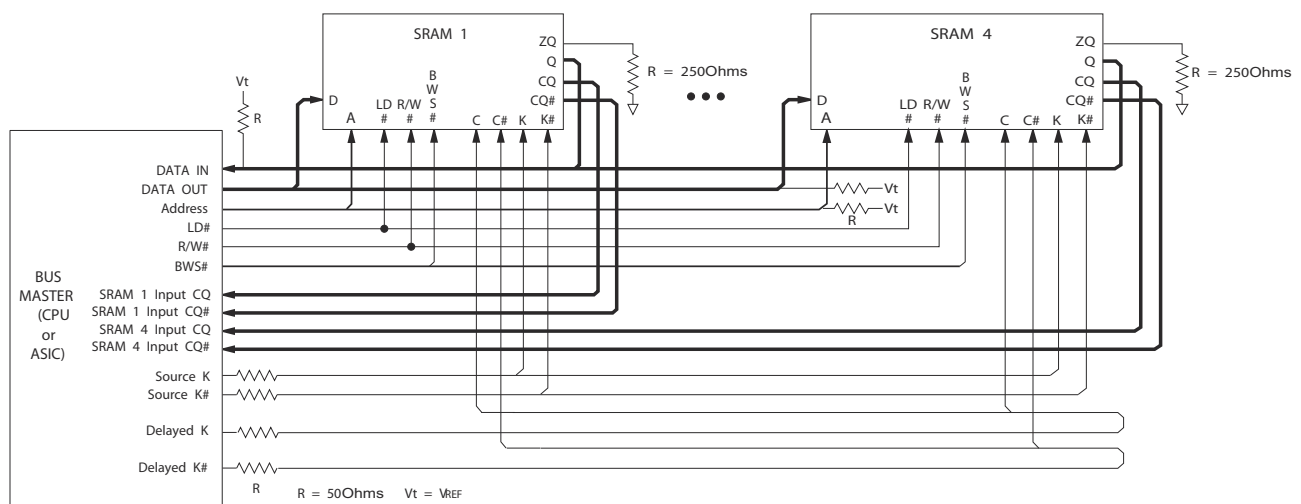

Truth Table

The truth table for CY7C1623KV18 is as follows: [2, 3, 4, 5, 6, 7]

Operation	K	$\overline{\text{LD}}$	$\overline{\text{R/W}}$	DQ	DQ
Write Cycle: Load address; wait one cycle; input write data on consecutive K and $\overline{\text{K}}$ rising edges.	L–H	L	L	D(A + 0) at K(t + 1) \uparrow	D(A + 1) at $\overline{\text{K}}$ (t + 1) \uparrow
Read Cycle: Load address; wait one and a half cycle; read data on consecutive $\overline{\text{C}}$ and C rising edges.	L–H	L	H	Q(A + 0) at $\overline{\text{C}}$ (t + 1) \uparrow	Q(A + 1) at C(t + 2) \uparrow
NOP: No Operation	L–H	H	X	High Z	High Z
Standby: Clock Stopped	Stopped	X	X	Previous State	Previous State

Write Cycle Descriptions

The write cycle description table for CY7C1623KV18 is as follows: [2, 8]

$\overline{\text{BWS}}_0$	$\overline{\text{BWS}}_1$	K	$\overline{\text{K}}$	Comments
L	L	L–H	–	During the data portion of a write sequence, both bytes (D _[17:0]) are written into the device.
L	L	–	L–H	During the data portion of a write sequence, both bytes (D _[17:0]) are written into the device.
L	H	L–H	–	During the data portion of a write sequence, only the lower byte (D _[8:0]) is written into the device, D _[17:9] remains unaltered.
L	H	–	L–H	During the data portion of a write sequence, only the lower byte (D _[8:0]) is written into the device, D _[17:9] remains unaltered.
H	L	L–H	–	During the data portion of a write sequence, only the upper byte (D _[17:9]) is written into the device, D _[8:0] remains unaltered.
H	L	–	L–H	During the data portion of a write sequence, only the upper byte (D _[17:9]) is written into the device, D _[8:0] remains unaltered.
H	H	L–H	–	No data is written into the devices during this portion of a write operation.
H	H	–	L–H	No data is written into the devices during this portion of a write operation.

Notes

- X = "Don't Care," H = Logic HIGH, L = Logic LOW, \uparrow represents rising edge.
- Device powers up deselected with the outputs in a tri-state condition.
- "A" represents address location latched by the devices when transaction was initiated. A + 0, A + 1 represents the internal address sequence in the burst.
- "t" represents the cycle at which a Read/Write operation is started. t + 1, and t + 2 are the first, and second clock cycles respectively succeeding the "t" clock cycle.
- Data inputs are registered at K and $\overline{\text{K}}$ rising edges. Data outputs are delivered on C and $\overline{\text{C}}$ rising edges, except when in single clock mode.
- Ensure that when clock is stopped K = $\overline{\text{K}}$ and C = $\overline{\text{C}}$ = HIGH. This is not essential, but permits most rapid restart by overcoming transmission line charging symmetrically.
- Is based on a write cycle that was initiated in accordance with the Write Cycle Descriptions table. $\overline{\text{BWS}}_0$ and $\overline{\text{BWS}}_1$ can be altered on different portions of a write cycle, as long as the setup and hold requirements are achieved.

IEEE 1149.1 Serial Boundary Scan (JTAG)

These SRAMs incorporate a serial boundary scan Test Access Port (TAP) in the FBGA package. This part is fully compliant with IEEE Standard 1149.1-2001. The TAP operates using JEDEC standard 1.8 V I/O logic levels.

Disabling the JTAG Feature

It is possible to operate the SRAM without using the JTAG feature. To disable the TAP controller, TCK must be tied LOW (V_{SS}) to prevent clocking of the device. TDI and TMS are internally pulled up and may be unconnected. They may alternatively be connected to V_{DD} through a pull up resistor. TDO must be left unconnected. Upon power up, the device comes up in a reset state, which does not interfere with the operation of the device.

Test Access Port

Test Clock

The test clock is used only with the TAP controller. All inputs are captured on the rising edge of TCK. All outputs are driven from the falling edge of TCK.

Test Mode Select (TMS)

The TMS input is used to give commands to the TAP controller and is sampled on the rising edge of TCK. This pin may be left unconnected if the TAP is not used. The pin is pulled up internally, resulting in a logic HIGH level.

Test Data-In (TDI)

The TDI pin is used to serially input information into the registers and can be connected to the input of any of the registers. The register between TDI and TDO is chosen by the instruction that is loaded into the TAP instruction register. For information about loading the instruction register, see the [TAP Controller State Diagram on page 11](#). TDI is internally pulled up and can be unconnected if the TAP is unused in an application. TDI is connected to the most significant bit (MSB) on any register.

Test Data-Out (TDO)

The TDO output pin is used to serially clock data out from the registers. The output is active, depending upon the current state of the TAP state machine (see [Instruction Codes on page 15](#)). The output changes on the falling edge of TCK. TDO is connected to the least significant bit (LSB) of any register.

Performing a TAP Reset

A Reset is performed by forcing TMS HIGH (V_{DD}) for five rising edges of TCK. This Reset does not affect the operation of the SRAM and can be performed while the SRAM is operating. At power up, the TAP is reset internally to ensure that TDO comes up in a high Z state.

TAP Registers

Registers are connected between the TDI and TDO pins to scan the data in and out of the SRAM test circuitry. Only one register can be selected at a time through the instruction registers. Data is serially loaded into the TDI pin on the rising edge of TCK. Data is output on the TDO pin on the falling edge of TCK.

Instruction Register

Three-bit instructions can be serially loaded into the instruction register. This register is loaded when it is placed between the TDI and TDO pins, as shown in [TAP Controller Block Diagram on page 12](#). Upon power up, the instruction register is loaded with the IDCODE instruction. It is also loaded with the IDCODE instruction if the controller is placed in a reset state, as described in the previous section.

When the TAP controller is in the Capture-IR state, the two least significant bits are loaded with a binary '01' pattern to allow for fault isolation of the board level serial test path.

Bypass Register

To save time when serially shifting data through registers, it is sometimes advantageous to skip certain chips. The bypass register is a single-bit register that can be placed between TDI and TDO pins. This enables shifting of data through the SRAM with minimal delay. The bypass register is set LOW (V_{SS}) when the BYPASS instruction is executed.

Boundary Scan Register

The boundary scan register is connected to all of the input and output pins on the SRAM. Several No Connect (NC) pins are also included in the scan register to reserve pins for higher density devices.

The boundary scan register is loaded with the contents of the RAM input and output ring when the TAP controller is in the Capture-DR state and is then placed between the TDI and TDO pins when the controller is moved to the Shift-DR state. The EXTEST, SAMPLE/PRELOAD, and SAMPLE Z instructions can be used to capture the contents of the input and output ring.

The [Boundary Scan Order on page 16](#) shows the order in which the bits are connected. Each bit corresponds to one of the bumps on the SRAM package. The MSB of the register is connected to TDI, and the LSB is connected to TDO.

Identification (ID) Register

The ID register is loaded with a vendor-specific, 32-bit code during the Capture-DR state when the IDCODE command is loaded in the instruction register. The IDCODE is hardwired into the SRAM and can be shifted out when the TAP controller is in the Shift-DR state. The ID register has a vendor code and other information described in [Identification Register Definitions on page 15](#).

TAP Instruction Set

Eight different instructions are possible with the three-bit instruction register. All combinations are listed in [Instruction Codes on page 15](#). Three of these instructions are listed as RESERVED and must not be used. The other five instructions are described in this section in detail.

Instructions are loaded into the TAP controller during the Shift-IR state when the instruction register is placed between TDI and TDO. During this state, instructions are shifted through the instruction register through the TDI and TDO pins. To execute the instruction after it is shifted in, the TAP controller must be moved into the Update-IR state.

IDCODE

The IDCODE instruction loads a vendor-specific, 32-bit code into the instruction register. It also places the instruction register between the TDI and TDO pins and shifts the IDCODE out of the device when the TAP controller enters the Shift-DR state. The IDCODE instruction is loaded into the instruction register at power up or whenever the TAP controller is supplied a Test-Logic-Reset state.

SAMPLE Z

The SAMPLE Z instruction connects the boundary scan register between the TDI and TDO pins when the TAP controller is in a Shift-DR state. The SAMPLE Z command puts the output bus into a High Z state until the next command is supplied during the Update IR state.

SAMPLE/PRELOAD

SAMPLE/PRELOAD is a 1149.1 mandatory instruction. When the SAMPLE/PRELOAD instructions are loaded into the instruction register and the TAP controller is in the Capture-DR state, a snapshot of data on the input and output pins is captured in the boundary scan register.

The TAP controller clock can only operate at a frequency up to 20 MHz, while the SRAM clock operates more than an order of magnitude faster. Because there is a large difference in the clock frequencies, it is possible that during the Capture-DR state, an input or output undergoes a transition. The TAP may then try to capture a signal while in transition (metastable state). This does not harm the device, but there is no guarantee as to the value that is captured. Repeatable results may not be possible.

To guarantee that the boundary scan register captures the correct value of a signal, the SRAM signal must be stabilized long enough to meet the TAP controller's capture setup plus hold times (t_{CS} and t_{CH}). The SRAM clock input might not be captured correctly if there is no way in a design to stop (or slow) the clock during a SAMPLE/PRELOAD instruction. If this is an issue, it is still possible to capture all other signals and simply ignore the value of the CK and CK captured in the boundary scan register.

After the data is captured, it is possible to shift out the data by putting the TAP into the Shift-DR state. This places the boundary scan register between the TDI and TDO pins.

PRELOAD places an initial data pattern at the latched parallel outputs of the boundary scan register cells before the selection of another boundary scan test operation.

The shifting of data for the SAMPLE and PRELOAD phases can occur concurrently when required, that is, while the data captured is shifted out, the preloaded data can be shifted in.

BYPASS

When the BYPASS instruction is loaded in the instruction register and the TAP is placed in a Shift-DR state, the bypass register is placed between the TDI and TDO pins. The advantage of the BYPASS instruction is that it shortens the boundary scan path when multiple devices are connected together on a board.

EXTEST

The EXTEST instruction drives the preloaded data out through the system output pins. This instruction also connects the boundary scan register for serial access between the TDI and TDO in the Shift-DR controller state.

EXTEST OUTPUT BUS TRI-STATE

IEEE Standard 1149.1 mandates that the TAP controller be able to put the output bus into a tri-state mode.

The boundary scan register has a special bit located at bit 108. When this scan cell, called the 'extest output bus tri-state', is latched into the preload register during the Update-DR state in the TAP controller, it directly controls the state of the output (Q-bus) pins, when the EXTEST is entered as the current instruction. When HIGH, it enables the output buffers to drive the output bus. When LOW, this bit places the output bus into a High Z condition.

This bit can be set by entering the SAMPLE/PRELOAD or EXTEST command, and then shifting the desired bit into that cell, during the Shift-DR state. During Update-DR, the value loaded into that shift-register cell latches into the preload register. When the EXTEST instruction is entered, this bit directly controls the output Q-bus pins. Note that this bit is pre-set LOW to enable the output when the device is powered up, and also when the TAP controller is in the Test-Logic-Reset state.

Reserved

These instructions are not implemented but are reserved for future use. Do not use these instructions.

TAP Controller State Diagram

The state diagram for the TAP controller follows: [9]

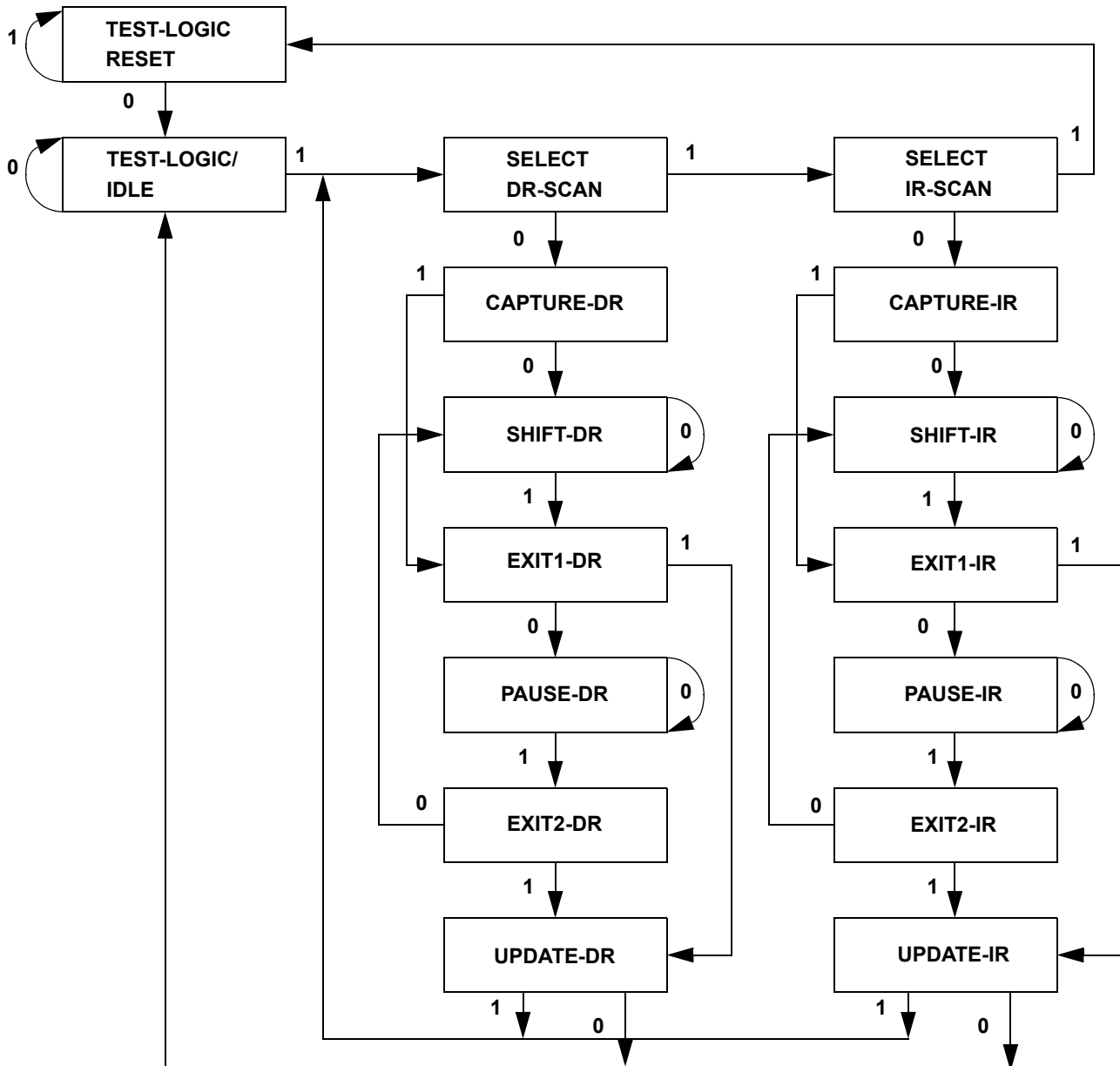

Note
9. The 0/1 next to each state represents the value at TMS at the rising edge of TCK.

TAP Controller Block Diagram

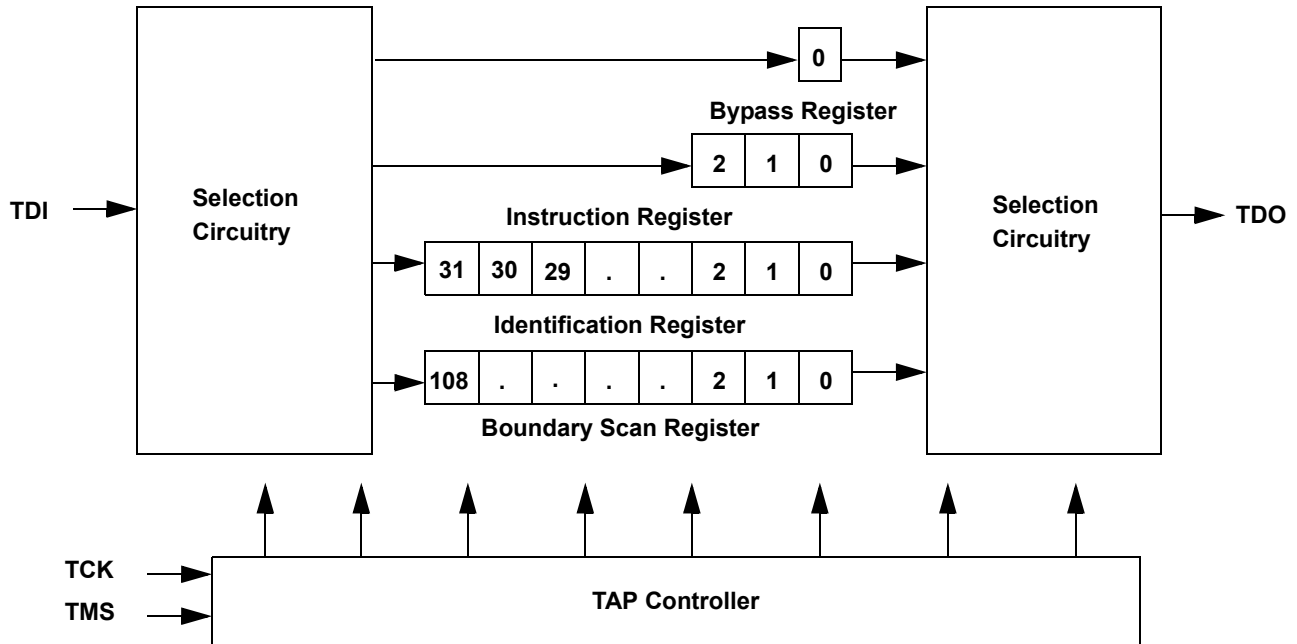

TAP Electrical Characteristics

Over the Operating Range

Parameter ^[10, 11, 12]	Description	Test Conditions	Min	Max	Unit
V _{OH1}	Output HIGH Voltage	I _{OH} = -2.0 mA	1.4	-	V
V _{OH2}	Output HIGH Voltage	I _{OH} = -100 μA	1.6	-	V
V _{OL1}	Output LOW Voltage	I _{OL} = 2.0 mA	-	0.4	V
V _{OL2}	Output LOW Voltage	I _{OL} = 100 μA	-	0.2	V
V _{IH}	Input HIGH Voltage		0.65 × V _{DD}	V _{DD} + 0.3	V
V _{IL}	Input LOW Voltage		-0.3	0.35 × V _{DD}	V
I _X	Input and Output Load Current	GND ≤ V _I ≤ V _{DD}	-5	5	μA

Notes

- 10. These characteristics pertain to the TAP inputs (TMS, TCK, TDI and TDO). Parallel load levels are specified in the [Electrical Characteristics on page 18](#).
- 11. Overshoot: V_{IH(AC)} < V_{DDQ} + 0.85 V (Pulse width less than t_{CYC/2}), Undershoot: V_{IL(AC)} > -1.5 V (Pulse width less than t_{CYC/2}).
- 12. All Voltage referenced to Ground.

TAP AC Switching Characteristics

Over the Operating Range

Parameter ^[13, 14]	Description	Min	Max	Unit
t_{TCYC}	TCK Clock Cycle Time	50	–	ns
t_{TF}	TCK Clock Frequency	–	20	MHz
t_{TH}	TCK Clock HIGH	20	–	ns
t_{TL}	TCK Clock LOW	20	–	ns
Setup Times				
t_{TMSS}	TMS Setup to TCK Clock Rise	5	–	ns
t_{TDIS}	TDI Setup to TCK Clock Rise	5	–	ns
t_{CS}	Capture Setup to TCK Rise	5	–	ns
Hold Times				
t_{TMSH}	TMS Hold after TCK Clock Rise	5	–	ns
t_{TDIH}	TDI Hold after Clock Rise	5	–	ns
t_{CH}	Capture Hold after Clock Rise	5	–	ns
Output Times				
t_{TDOV}	TCK Clock LOW to TDO Valid	–	10	ns
t_{TDOX}	TCK Clock LOW to TDO Invalid	0	–	ns

Notes

13. t_{CS} and t_{CH} refer to the setup and hold time requirements of latching data from the boundary scan register.

14. Test conditions are specified using the load in TAP AC Test Conditions. $t_R/t_F = 1$ ns.

TAP Timing and Test Conditions

Figure 3 shows the TAP timing and test conditions. [15]

Figure 3. TAP Timing and Test Conditions

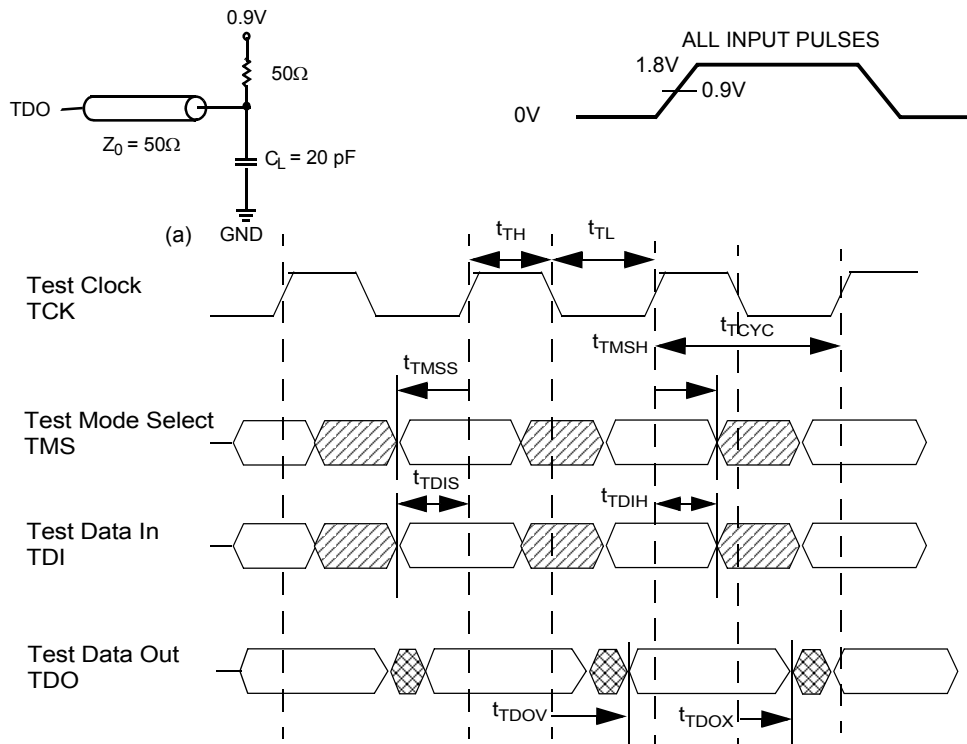

Note

15. Test conditions are specified using the load in TAP AC Test Conditions. $t_R/t_F = 1\text{ ns}$.

Identification Register Definitions

Instruction Field	Value	Description
	CY7C1623KV18	
Revision Number (31:29)	000	Version number.
Cypress Device ID (28:12)	11010100010010011	Defines the type of SRAM.
Cypress JEDEC ID (11:1)	00000110100	Allows unique identification of SRAM vendor.
ID Register Presence (0)	1	Indicates the presence of an ID register.

Scan Register Sizes

Register Name	Bit Size
Instruction	3
Bypass	1
ID	32
Boundary Scan	109

Instruction Codes

Instruction	Code	Description
EXTEST	000	Captures the input and output ring contents.
IDCODE	001	Loads the ID register with the vendor ID code and places the register between TDI and TDO. This operation does not affect SRAM operation.
SAMPLE Z	010	Captures the input and output contents. Places the boundary scan register between TDI and TDO. Forces all SRAM output drivers to a High Z state.
RESERVED	011	Do Not Use: This instruction is reserved for future use.
SAMPLE/PRELOAD	100	Captures the input and output ring contents. Places the boundary scan register between TDI and TDO. Does not affect the SRAM operation.
RESERVED	101	Do Not Use: This instruction is reserved for future use.
RESERVED	110	Do Not Use: This instruction is reserved for future use.
BYPASS	111	Places the bypass register between TDI and TDO. This operation does not affect SRAM operation.

Boundary Scan Order

Bit No.	Bump ID
0	6R
1	6P
2	6N
3	7P
4	7N
5	7R
6	8R
7	8P
8	9R
9	11P
10	10P
11	10N
12	9P
13	10M
14	11N
15	9M
16	9N
17	11L
18	11M
19	9L
20	10L
21	11K
22	10K
23	9J
24	9K
25	10J
26	11J
27	11H

Bit No.	Bump ID
28	10G
29	9G
30	11F
31	11G
32	9F
33	10F
34	11E
35	10E
36	10D
37	9E
38	10C
39	11D
40	9C
41	9D
42	11B
43	11C
44	9B
45	10B
46	11A
47	10A
48	9A
49	8B
50	7C
51	6C
52	8A
53	7A
54	7B
55	6B

Bit No.	Bump ID
56	6A
57	5B
58	5A
59	4A
60	5C
61	4B
62	3A
63	2A
64	1A
65	2B
66	3B
67	1C
68	1B
69	3D
70	3C
71	1D
72	2C
73	3E
74	2D
75	2E
76	1E
77	2F
78	3F
79	1G
80	1F
81	3G
82	2G
83	1H

Bit No.	Bump ID
84	1J
85	2J
86	3K
87	3J
88	2K
89	1K
90	2L
91	3L
92	1M
93	1L
94	3N
95	3M
96	1N
97	2M
98	3P
99	2N
100	2P
101	1P
102	3R
103	4R
104	4P
105	5P
106	5N
107	5R
108	Internal

Power Up Sequence in DDR-II SRAM

DDR-II SRAMs must be powered up and initialized in a predefined manner to prevent undefined operations.

Power Up Sequence

- Apply power and drive $\overline{\text{DOFF}}$ either HIGH or LOW (All other inputs can be HIGH or LOW).
 - Apply V_{DD} before V_{DDQ} .
 - Apply V_{DDQ} before V_{REF} or at the same time as V_{REF} .
 - Drive $\overline{\text{DOFF}}$ HIGH.
- Provide stable $\overline{\text{DOFF}}$ (HIGH), power and clock (K, \overline{K}) for 20 μs to lock the PLL.

PLL Constraints

- PLL uses K clock as its synchronizing input. The input must have low phase jitter, which is specified as $t_{\text{KC Var}}$.
- The PLL functions at frequencies down to 120 MHz.
- If the input clock is unstable and the PLL is enabled, then the PLL may lock onto an incorrect frequency, causing unstable SRAM behavior. To avoid this, provide 20 μs of stable clock to relock to the desired clock frequency.

Figure 4. Power Up Waveforms

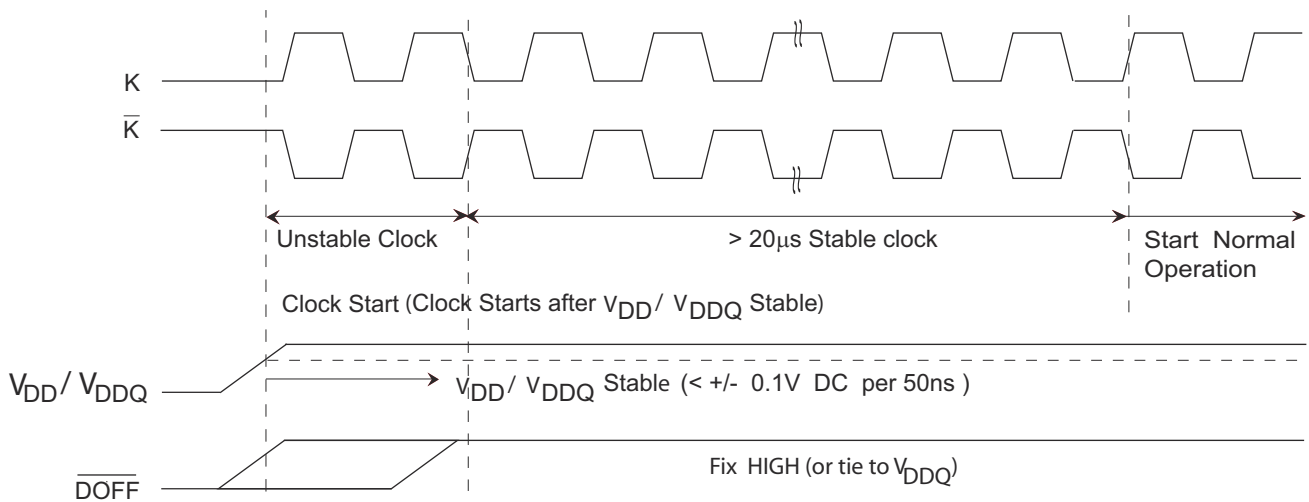

Maximum Ratings

Exceeding maximum ratings may impair the useful life of the device. These user guidelines are not tested.

Storage Temperature -65 °C to +150 °C
 Ambient Temperature
 with Power Applied -55 °C to +125 °C
 Supply Voltage on V_{DD} Relative to GND -0.5 V to +2.9 V
 Supply Voltage on V_{DDQ} Relative to GND -0.5 V to +V_{DD}
 DC Applied to Outputs in High Z -0.5 V to V_{DDQ} + 0.3 V
 DC Input Voltage ^[16] -0.5 V to V_{DD} + 0.3 V

Current into Outputs (LOW) 20 mA
 Static Discharge Voltage
 (MIL-STD-883, M. 3015) > 2001 V
 Latch-up Current > 200 mA

Operating Range

Range	Ambient Temperature (T _A)	V _{DD} ^[17]	V _{DDQ} ^[17]
Commercial	0 °C to +70 °C	1.8 ± 0.1 V	1.4 V to V _{DD}

Electrical Characteristics

Over the Operating Range

DC Electrical Characteristics

Over the Operating Range

Parameter ^[18]	Description	Test Conditions	Min	Typ	Max	Unit	
V _{DD}	Power Supply Voltage		1.7	1.8	1.9	V	
V _{DDQ}	I/O Supply Voltage		1.4	1.5	V _{DD}	V	
V _{OH}	Output HIGH Voltage	Note 19	V _{DDQ} /2 - 0.12	-	V _{DDQ} /2 + 0.12	V	
V _{OL}	Output LOW Voltage	Note 20	V _{DDQ} /2 - 0.12	-	V _{DDQ} /2 + 0.12	V	
V _{OH(LOW)}	Output HIGH Voltage	I _{OH} = -0.1 mA, Nominal Impedance	V _{DDQ} - 0.2	-	V _{DDQ}	V	
V _{OL(LOW)}	Output LOW Voltage	I _{OL} = 0.1 mA, Nominal Impedance	V _{SS}	-	0.2	V	
V _{IH}	Input HIGH Voltage		V _{REF} + 0.1	-	V _{DDQ} + 0.3	V	
V _{IL}	Input LOW Voltage		-0.3	-	V _{REF} - 0.1	V	
I _X	Input Leakage Current	GND ≤ V _I ≤ V _{DDQ}	-5	-	5	μA	
I _{OZ}	Output Leakage Current	GND ≤ V _I ≤ V _{DDQ} , Output Disabled	-5	-	5	μA	
V _{REF}	Input Reference Voltage ^[21]	Typical Value = 0.75 V	0.68	0.75	0.95	V	
I _{DD} ^[22]	V _{DD} Operating Supply	V _{DD} = Max, I _{OUT} = 0 mA, f = f _{MAX} = 1/t _{CYC}	333 MHz (× 18)	-	-	650	mA
			250 MHz (× 18)	-	-	560	mA
I _{SB1}	Automatic Power Down Current	Max V _{DD} , Both Ports Deselected, V _{IN} ≥ V _{IH} or V _{IN} ≤ V _{IL} , f = f _{MAX} = 1/t _{CYC} , Inputs Static	333 MHz (× 18)	-	-	410	mA
			250 MHz (× 18)	-	-	370	mA

Notes

16. Overshoot: V_{IH(AC)} < V_{DDQ} + 0.85 V (Pulse width less than t_{CYC}/2), Undershoot: V_{IL(AC)} > -1.5 V (Pulse width less than t_{CYC}/2).
17. Power up: assumes a linear ramp from 0 V to V_{DD(min)} within 200 ms. During this time V_{IH} < V_{DD} and V_{DDQ} ≤ V_{DD}.
18. All Voltage referenced to Ground.
19. Outputs are impedance controlled. I_{OH} = -(V_{DDQ}/2)/(RQ/5) for values of 175 Ω ≤ RQ ≤ 350 Ω.
20. Outputs are impedance controlled. I_{OL} = (V_{DDQ}/2)/(RQ/5) for values of 175 Ω ≤ RQ ≤ 350 Ω.
21. V_{REF(min)} = 0.68 V or 0.46 V_{DDQ}, whichever is larger, V_{REF(max)} = 0.95 V or 0.54 V_{DDQ}, whichever is smaller.
22. The operation current is calculated with 50% read cycle and 50% write cycle.

AC Electrical Characteristics

Over the Operating Range

Parameter ^[23]	Description	Test Conditions	Min	Typ	Max	Unit
V_{IH}	Input HIGH voltage		$V_{REF} + 0.2$	–	–	V
V_{IL}	Input LOW voltage		–	–	$V_{REF} - 0.2$	V

Capacitance

Parameter ^[24]	Description	Test Conditions	Max	Unit
C_{IN}	Input capacitance	$T_A = 25\text{ }^\circ\text{C}$, $f = 1\text{ MHz}$, $V_{DD} = 1.8\text{ V}$, $V_{DDQ} = 1.5\text{ V}$	2	pF
C_O	Output capacitance		3	pF

Thermal Resistance

Parameter ^[24]	Description	Test Conditions	165-ball FBGA Package	Unit
Θ_{JA}	Thermal resistance (junction to ambient)	Test conditions follow standard test methods and procedures for measuring thermal impedance, in accordance with EIA/JESD51.	12.55	$^\circ\text{C/W}$
Θ_{JC}	Thermal resistance (junction to case)		2.49	$^\circ\text{C/W}$

AC Test Loads and Waveforms

Figure 5. AC Test Loads and Waveforms

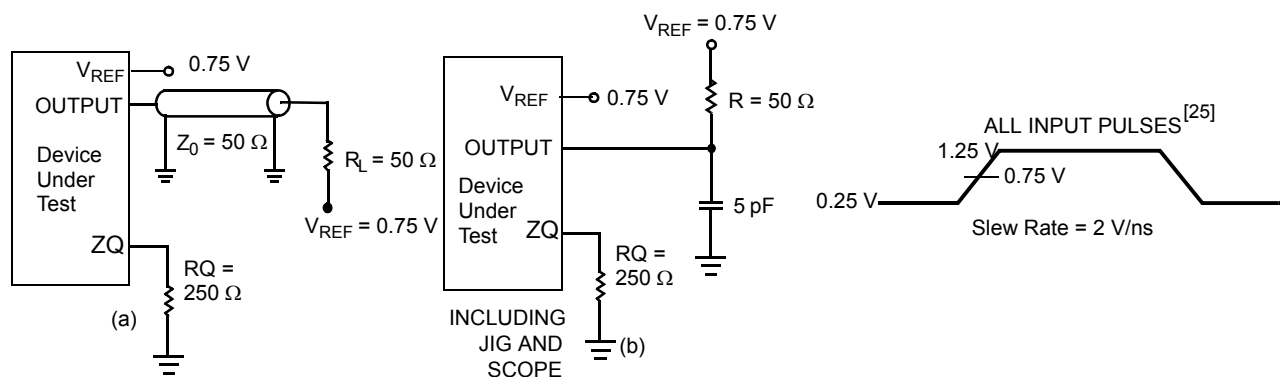

Notes

23. Overshoot: $V_{IH(AC)} < V_{DDQ} + 0.85\text{ V}$ (Pulse width less than $t_{CYC}/2$). Undershoot: $V_{IL(AC)} > -1.5\text{ V}$ (Pulse width less than $t_{CYC}/2$).

24. Tested initially and after any design or process change that may affect these parameters.

25. Unless otherwise noted, test conditions are based on signal transition time of 2 V/ns, timing reference levels of 0.75 V, $V_{ref} = 0.75\text{ V}$, $R_Q = 250\ \Omega$, $V_{DDQ} = 1.5\text{ V}$, input pulse levels of 0.25 V to 1.25 V, and output loading of the specified I_{OL}/I_{OH} and load capacitance shown in (a) of Figure 5.

Switching Characteristics

Over the Operating Range

Parameters ^[26, 27]		Description	333 MHz		250 MHz		Unit
Cypress Parameter	Consortium Parameter		Min	Max	Min	Max	
t _{POWER}		V _{DD} (typical) to the first access ^[28]	1	–	1	–	ms
t _{CYC}	t _{KHKH}	K clock and C clock cycle time	3.0	8.4	4.0	8.4	ns
t _{KH}	t _{KHKL}	Input clock (K/ \bar{K} ; C/ \bar{C}) HIGH	1.20	–	1.6	–	ns
t _{KL}	t _{KLKH}	Input clock (K/ \bar{K} ; C/ \bar{C}) LOW	1.20	–	1.6	–	ns
t _{KH\bar{K}H}	t _{KH\bar{K}H}	K clock rise to \bar{K} clock rise and C to \bar{C} rise (rising edge to rising edge)	1.35	–	1.8	–	ns
t _{KHCH}	t _{KHCH}	K/ \bar{K} clock rise to C/ \bar{C} clock rise (rising edge to rising edge)	0	1.30	0	1.8	ns
Setup Times							
t _{SA}	t _{AVKH}	Address setup to K clock rise	0.4	–	0.5	–	ns
t _{SC}	t _{IVKH}	Control setup to K clock rise (\overline{LD} , R/\overline{W})	0.4	–	0.5	–	ns
t _{SCDDR}	t _{IVKH}	Double data rate control setup to clock (K/ \bar{K}) rise (BWS ₀ , BWS ₁)	0.3	–	0.35	–	ns
t _{SD}	t _{DVKH}	D _[X:0] setup to clock (K/ \bar{K}) rise	0.3	–	0.35	–	ns
Hold Times							
t _{HA}	t _{KHAX}	Address hold after K clock rise	0.4	–	0.5	–	ns
t _{HC}	t _{KHIX}	Control hold after K clock rise (\overline{LD} , R/\overline{W})	0.4	–	0.5	–	ns
t _{HCDDR}	t _{KHIX}	Double data rate control hold after clock (K/ \bar{K}) rise (BWS ₀ , BWS ₁)	0.3	–	0.35	–	ns
t _{HD}	t _{KHDX}	D _[X:0] hold after clock (K/ \bar{K}) rise	0.3	–	0.35	–	ns

Notes

26. Unless otherwise noted, test conditions are based on signal transition time of 2 V/ns, timing reference levels of 0.75 V, V_{ref} = 0.75 V, R_Q = 250 Ω , V_{DDQ} = 1.5 V, input pulse levels of 0.25 V to 1.25 V, and output loading of the specified I_{OL}/I_{OH} and load capacitance shown in (a) of Figure 5 on page 19.

27. When a part with a maximum frequency above 167 MHz is operating at a lower clock frequency, it requires the input timings of the frequency range in which it is being operated and outputs data with the output timings of that frequency range.

28. This part has a voltage regulator internally; t_{POWER} is the time that the power must be supplied above V_{DD(minimum)} initially before a read or write operation can be initiated.

Switching Characteristics (continued)

Over the Operating Range

Parameters ^[26, 27]		Description	333 MHz		250 MHz		Unit
Cypress Parameter	Consortium Parameter		Min	Max	Min	Max	
Output Times							
t_{CO}	t_{CHQV}	C/\overline{C} clock rise (or K/\overline{K} in single clock mode) to data valid	–	0.45	–	0.45	ns
t_{DOH}	t_{CHQX}	Data output hold after output C/\overline{C} clock rise (active to active)	–0.45	–	–0.45	–	ns
t_{CCQO}	t_{CHCQV}	C/\overline{C} clock rise to echo clock valid	–	0.45	–	0.45	ns
t_{CQOH}	t_{CHCQX}	Echo clock hold after C/\overline{C} clock rise	–0.45	–	–0.45	–	ns
t_{CQD}	t_{CQHQV}	Echo clock high to data valid	–	0.25	–	0.30	ns
t_{CQDOH}	t_{CQHQX}	Echo clock high to data invalid	–0.25	–	–0.30	–	ns
t_{CQH}	t_{CQHCQL}	Output clock (CQ/\overline{CQ}) HIGH ^[29]	1.25	–	1.75	–	ns
$t_{CQH\overline{CQH}}$	$t_{CQH\overline{CQH}}$	CQ clock rise to \overline{CQ} clock rise (rising edge to rising edge) ^[29]	1.25	–	1.75	–	ns
t_{CHZ}	t_{CHQZ}	Clock (C/\overline{C}) rise to high Z (active to high Z) ^[30, 31]	–	0.45	–	0.45	ns
t_{CLZ}	t_{CHQX1}	Clock (C/\overline{C}) rise to low Z ^[30, 31]	–0.45	–	–0.45	–	ns
PLL Timing							
$t_{KC\ Var}$	$t_{KC\ Var}$	Clock phase jitter	–	0.20	–	0.20	ns
$t_{KC\ lock}$	$t_{KC\ lock}$	PLL lock time (K, C)	20	–	20	–	μ s
$t_{KC\ Reset}$	$t_{KC\ Reset}$	K static to PLL reset	30	–	30	–	ns

Notes

29. These parameters are extrapolated from the input timing parameters ($t_{CYC}/2 - 250$ ps, where 250 ps is the internal jitter). These parameters are only guaranteed by design and are not tested in production.

30. t_{CHZ} , t_{CLZ} , are specified with a load capacitance of 5 pF as in (b) of [Figure 5 on page 19](#). Transition is measured ± 100 mV from steady-state voltage.

31. At any voltage and temperature t_{CHZ} is less than t_{CLZ} and t_{CHZ} less than t_{CO} .

Switching Waveforms

Figure 6. Read/Write/Deselect Sequence [32, 33, 34]

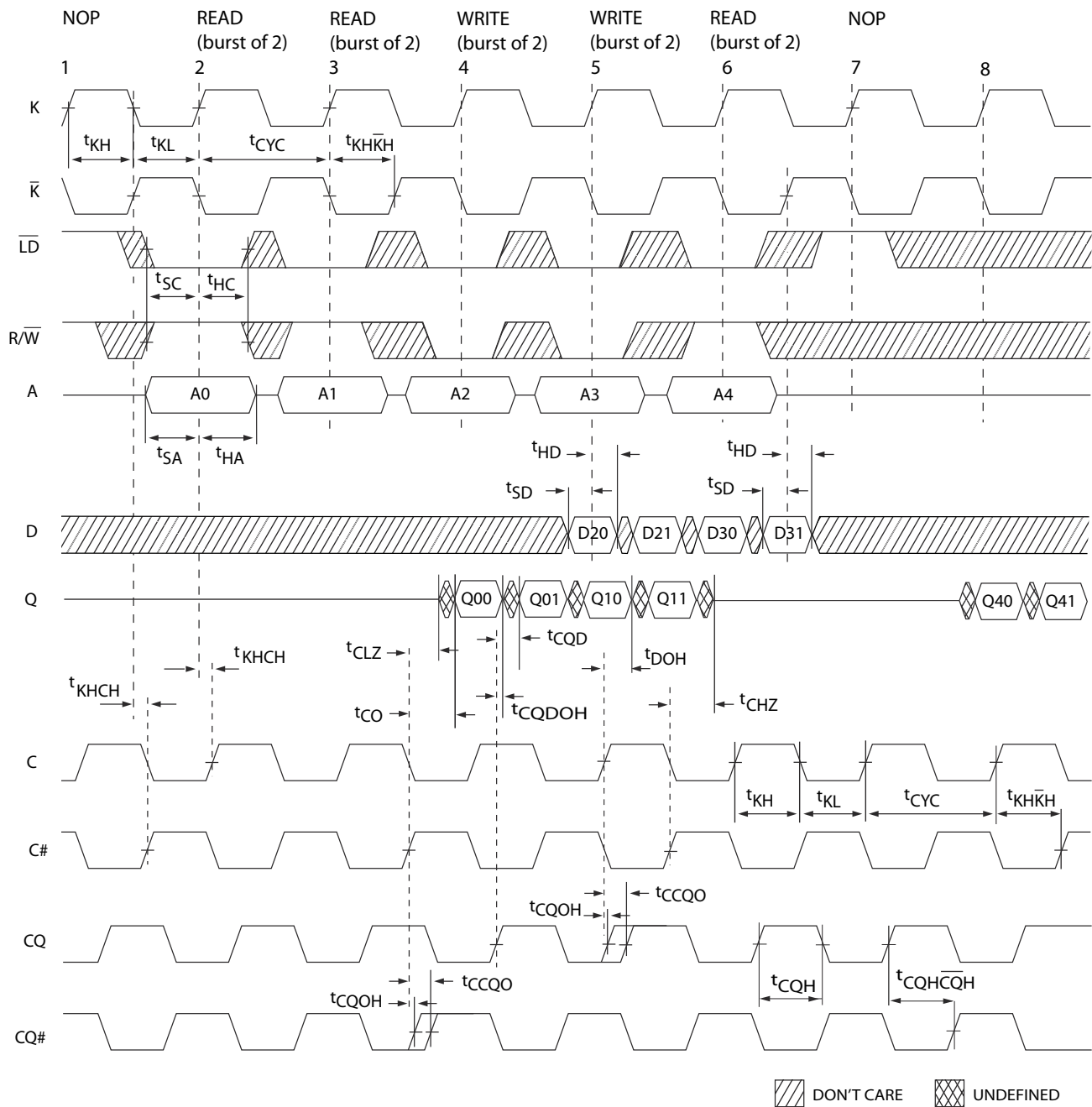

Notes

32. Q00 refers to output from address A0. Q01 refers to output from the next internal burst address following A0, that is, A0 + 1.

33. Outputs are disabled (High Z) one clock cycle after a NOP.

34. In this example, if address A4 = A3, then data Q40 = D30 and Q41 = D31. Write data is forwarded immediately as read results. This note applies to the whole diagram.

Ordering Information

Not all of the speed, package, and temperature ranges are available. Please contact your local sales representative or visit www.cypress.com for actual products offered.

Speed (MHz)	Ordering Code	Package Diagram	Package Type	Operating Range
333	CY7C1623KV18-333BZXC	51-85195	165-ball FBGA (15 × 17 × 1.4 mm) Pb-free	Commercial
250	CY7C1623KV18-250BZXC	51-85195	165-ball FBGA (15 × 17 × 1.4 mm) Pb-free	Commercial

Ordering Code Definitions

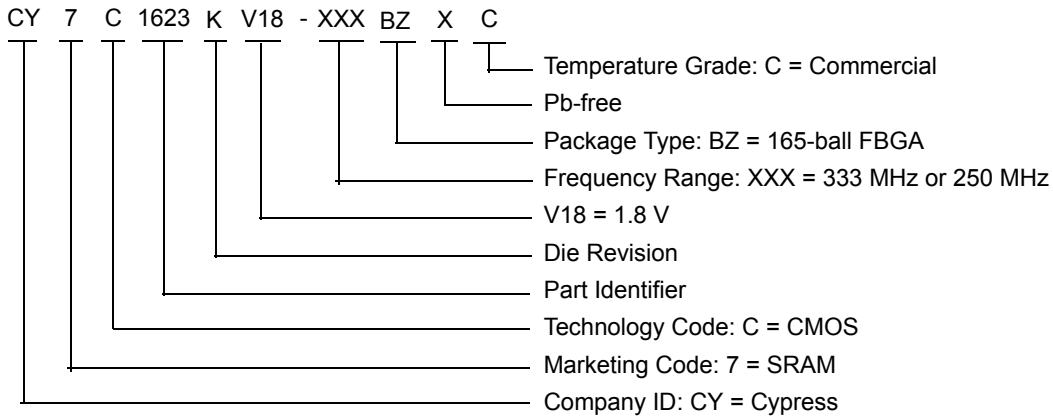

Package Diagram

Figure 7. 165-ball FBGA (15 × 17 × 1.40 mm) (0.50 Ball Diameter) Package Outline, 51-85195

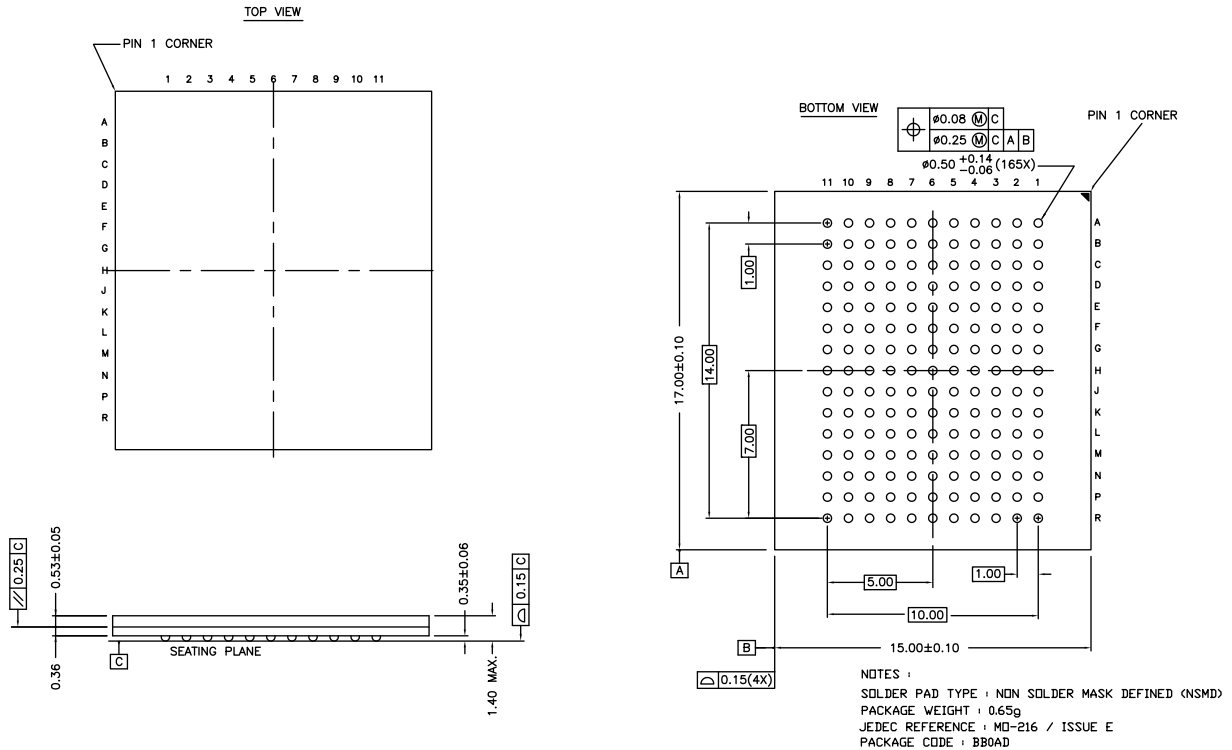

51-85195 *C

Acronyms

Acronym	Description
BWS	Byte Write Select
DDR	Double Data Rate
DLL	Delay Lock Loop
FBGA	Fine-Pitch Ball Grid Array
HSTL	High-Speed Transceiver Logic
I/O	input/output
JTAG	Joint Test Action Group
LSB	Least Significant Bit
LSBU	Logical Single-Bit Upsets
LMBU	Logical Multi-Bit Upsets
MSB	Most Significant Bit
PLL	Phase Locked Loop
QDR	Quad Data Rate
SEL	Single Event Latch Up
SRAM	Static Random Access Memory
TAP	Test Access Port
TCK	Test Clock
TDI	Test Data-In
TDO	Test Data-Out
TMS	Test Mode Select

Document Conventions

Units of Measure

Symbol	Unit of Measure
°C	degree Celsius
FIT/Dev	failure in time per device
FIT/Mb	failure in time per mega bit
MHz	megahertz
μA	microampere
μs	microsecond
mA	milliampere
mm	millimeter
ms	millisecond
ns	nanosecond
Ω	ohm
%	percent
pF	picofarad
V	volt
W	watt

Document History Page

Document Title: CY7C1623KV18, 144-Mbit DDR-II SIO SRAM Two-Word Burst Architecture Document Number: 001-44276				
Rev.	ECN No.	Submission Date	Orig. of Change	Description of Change
**	1961327	See ECN	VKN / PYRS	New data sheet.
*A	2555945	08/22/08	VKN / PYRS	Updated Identification Register Definitions (Changed Revision Number (31:29) from 001 to 000). Updated Power Up Sequence in DDR-II SRAM (Updated description and Figure 4). Updated Maximum Ratings (Changed Ambient Temperature with Power Applied from “-10 °C to +85 °C” to “-55 °C to +125 °C”). Updated Electrical Characteristics (Changed the maximum values of I _{DD} and I _{SB1} parameters). Updated Thermal Resistance (Included values for 165-ball FBGA package).
*B	3228953	04/15/2011	NJY	Changed status from Preliminary to Final. Updated Ordering Information (updated part numbers) and added Ordering Code Definitions . Updated Package Diagram . Added Acronyms and Units of Measure . Updated in new template.
*C	3243572	04/28/2011	NJY	Minor text edits across the document.
*D	3275033	06/06/2011	NJY	No technical updates.
*E	3428174	11/04/2011	NJY	Updated Package Diagram .

Document History Page (continued)

Document Title: CY7C1623KV18, 144-Mbit DDR-II SIO SRAM Two-Word Burst Architecture				
Document Number: 001-44276				
Rev.	ECN No.	Submission Date	Orig. of Change	Description of Change
*F	3577172	04/10/2012	AVIA / PRIT	<p>Updated Features (Removed CY7C1622KV18, CY7C1629KV18, and CY7C1624KV18 related information, removed non Pb-free packages).</p> <p>Updated Configuration (Removed CY7C1622KV18, CY7C1629KV18, and CY7C1624KV18 related information).</p> <p>Updated Functional Description (Removed CY7C1622KV18, CY7C1629KV18, and CY7C1624KV18 related information).</p> <p>Updated Selection Guide (Removed CY7C1622KV18, CY7C1629KV18, and CY7C1624KV18 related information, removed 300 MHz, 200 MHz and 167 MHz frequencies related information).</p> <p>Removed Logic Block Diagram – CY7C1622KV18.</p> <p>Removed Logic Block Diagram – CY7C1629KV18.</p> <p>Removed Logic Block Diagram – CY7C1624KV18.</p> <p>Updated Pin Configurations (Removed CY7C1622KV18, CY7C1629KV18, and CY7C1624KV18 related information).</p> <p>Updated Pin Definitions (Removed CY7C1622KV18, CY7C1629KV18, and CY7C1624KV18 related information).</p> <p>Updated Functional Overview (Removed CY7C1622KV18, CY7C1629KV18, and CY7C1624KV18 related information).</p> <p>Updated Truth Table (Removed CY7C1622KV18, CY7C1629KV18, and CY7C1624KV18 related information).</p> <p>Updated Write Cycle Descriptions (Removed CY7C1622KV18 related information).</p> <p>Removed Write Cycle Descriptions (Corresponding to CY7C1629KV18 and CY7C1624KV18).</p> <p>Updated IEEE 1149.1 Serial Boundary Scan (JTAG) (Removed CY7C1622KV18, CY7C1629KV18, and CY7C1624KV18 related information).</p> <p>Updated Identification Register Definitions (Removed CY7C1622KV18, CY7C1629KV18, and CY7C1624KV18 related information).</p> <p>Updated Operating Range (Removed Industrial Temperature Range).</p> <p>Updated Electrical Characteristics (Updated DC Electrical Characteristics (Removed CY7C1622KV18, CY7C1629KV18, and CY7C1624KV18 related information, removed 300 MHz, 200 MHz and 167 MHz frequencies related information)).</p> <p>Updated Switching Characteristics (Removed 300 MHz, 200 MHz and 167 MHz frequencies related information).</p> <p>Replaced all instances of IO with I/O across the document.</p>
*G	3947120	03/28/2013	PRIT	No technical updates. Completing sunset review.

Sales, Solutions, and Legal Information

Worldwide Sales and Design Support

Cypress maintains a worldwide network of offices, solution centers, manufacturer's representatives, and distributors. To find the office closest to you, visit us at cypress.com/sales.

Products

Automotive	cypress.com/go/automotive
Clocks & Buffers	cypress.com/go/clocks
Interface	cypress.com/go/interface
Lighting & Power Control	cypress.com/go/powerpsoc cypress.com/go/plc
Memory	cypress.com/go/memory
Optical & Image Sensing	cypress.com/go/image
PSoC	cypress.com/go/psoc
Touch Sensing	cypress.com/go/touch
USB Controllers	cypress.com/go/USB
Wireless/RF	cypress.com/go/wireless

PSoC Solutions

psoc.cypress.com/solutions
PSoC 1 | PSoC 3 | PSoC 5

© Cypress Semiconductor Corporation, 2008-2013. The information contained herein is subject to change without notice. Cypress Semiconductor Corporation assumes no responsibility for the use of any circuitry other than circuitry embodied in a Cypress product. Nor does it convey or imply any license under patent or other rights. Cypress products are not warranted nor intended to be used for medical, life support, life saving, critical control or safety applications, unless pursuant to an express written agreement with Cypress. Furthermore, Cypress does not authorize its products for use as critical components in life-support systems where a malfunction or failure may reasonably be expected to result in significant injury to the user. The inclusion of Cypress products in life-support systems application implies that the manufacturer assumes all risk of such use and in doing so indemnifies Cypress against all charges.

Any Source Code (software and/or firmware) is owned by Cypress Semiconductor Corporation (Cypress) and is protected by and subject to worldwide patent protection (United States and foreign), United States copyright laws and international treaty provisions. Cypress hereby grants to licensee a personal, non-exclusive, non-transferable license to copy, use, modify, create derivative works of, and compile the Cypress Source Code and derivative works for the sole purpose of creating custom software and or firmware in support of licensee product to be used only in conjunction with a Cypress integrated circuit as specified in the applicable agreement. Any reproduction, modification, translation, compilation, or representation of this Source Code except as specified above is prohibited without the express written permission of Cypress.

Disclaimer: CYPRESS MAKES NO WARRANTY OF ANY KIND, EXPRESS OR IMPLIED, WITH REGARD TO THIS MATERIAL, INCLUDING, BUT NOT LIMITED TO, THE IMPLIED WARRANTIES OF MERCHANTABILITY AND FITNESS FOR A PARTICULAR PURPOSE. Cypress reserves the right to make changes without further notice to the materials described herein. Cypress does not assume any liability arising out of the application or use of any product or circuit described herein. Cypress does not authorize its products for use as critical components in life-support systems where a malfunction or failure may reasonably be expected to result in significant injury to the user. The inclusion of Cypress' product in a life-support systems application implies that the manufacturer assumes all risk of such use and in doing so indemnifies Cypress against all charges.

Use may be limited by and subject to the applicable Cypress software license agreement.