

SDKC-89-39

REVISIONS

ISSUE	CHANGES
14	CN 37170 A REDRAWN PG 11/01/96
S	ER 15181 PSM 04/30/09

JJS101

SCALE 4:1

APPROX SURFACE AREA

USED ON

REF: RICHMOND PRODUCTS CO. Q-10
HARRIS CORP. J96-0005-001

CAP ASS'Y, BNC, M

DRAWN PG DATE 11/01/96

DESIGN LI DATE 11/04/96

APPR. DATE



Winchester Electronics
62 Barnes Industrial
Road North
Wallingford, CT 06492

A
SIZE

SDKC-89-39

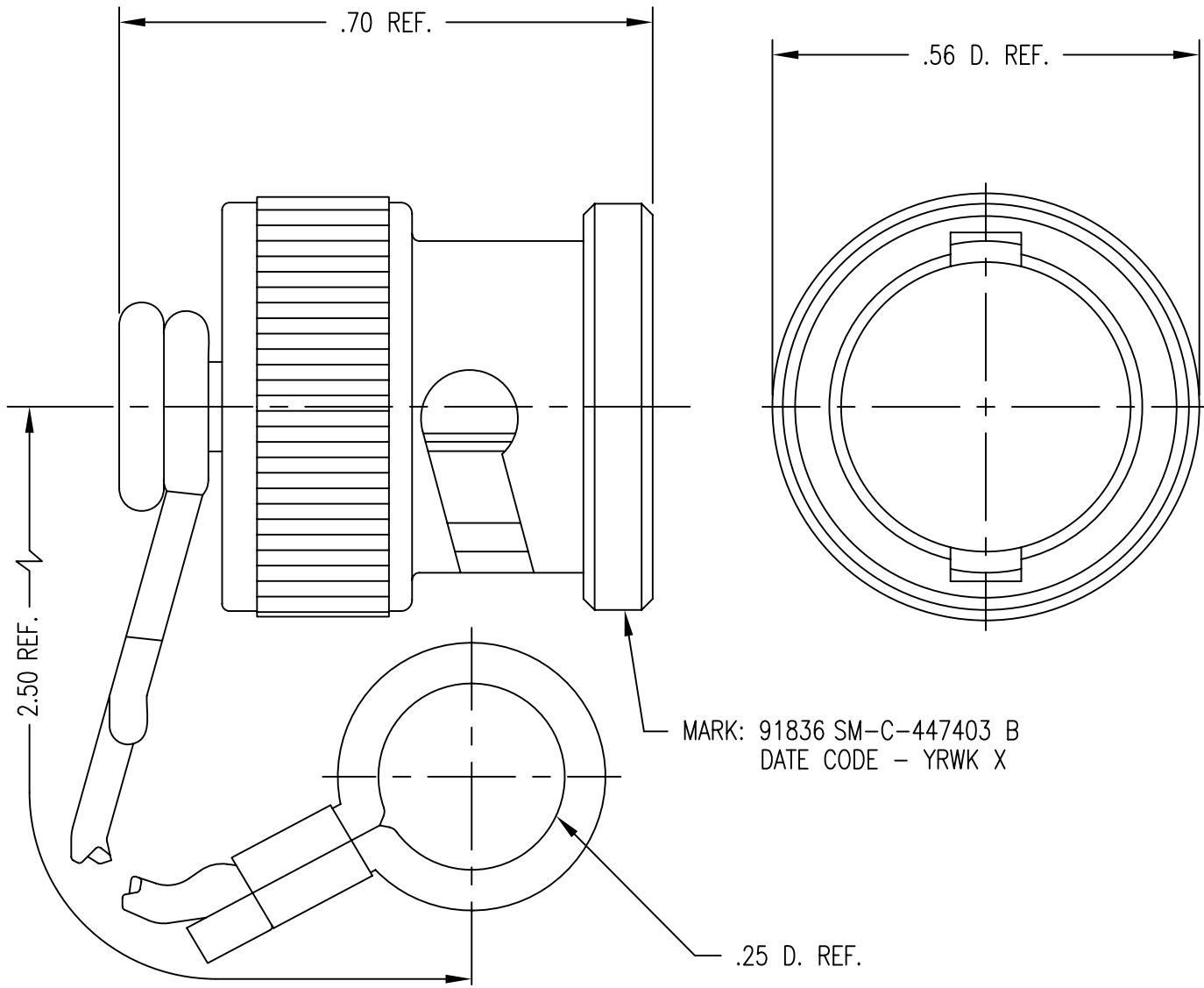

MARK: 91836 SM-C-447403 B
DATE CODE - YRWK X

NOTES:

1. MARK PACKAGE: KINGS KC-89-39
XX XX (DATE CODE)
91836 SM-C-447403 B

2. MATERIALS:
PAD: SILICONE RUBBER, ZZ-R-765, OLIVE GREEN.
CORD: CORELESS NYLON CORD PER MIL-C-7515.
CLIP: STAINLESS STEEL-BLACKNED
ALL OTHER METAL PARTS: BRASS, ASTM-B16, H02

3. FINISHES:
CAP & BAYONET SLEEVES:
OLIVE GREEN PAINT PER TT-E-529 OVER
SILVER PLATE, QQ-S-365.
ALL OTHER METAL PARTS:
KINGS TARNISH RESISTANT NICKEL FINISH (TR-5)