

MATERIAL SPECIFICATIONS:

Body & Housing: PA, UL-94V-0 rated, color black
 Contacts: Brass, Gold plated

MECHANICAL SPECIFICATIONS:

Wire gauge: 0.25mm² / 24AWG
 Durability: 500 mating cycles min.

ELECTRICAL SPECIFICATIONS:

Rated current / voltage:
 3 contact = 3A / 125V per contact
 4 contact = 2.5A / 125V per contact
 5 contact = 2A / 63V per contact
 8 contact = 1A / 63V per contact

Contact resistance: 3 mohms max.

Rated impulse voltage:

3A & 2.5A = 1500V
 2A & 1A = 800V

IEC/UL 61010-1 SPECIFICATIONS:

Material group: I, II
 Overload category: II
 Pollution degree: 2

ENVIRONMENTAL SPECIFICATIONS:

Degree of Protection: IP67
 Operating Temperature: -25°C ~ +85°C

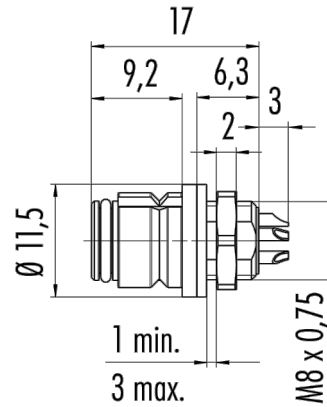

SOLDER TERMINALS

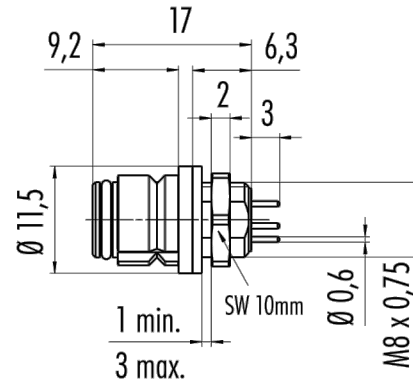

PCB PINS

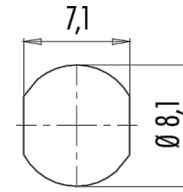

PANEL CUTOUT

ORDERING CODE:

PD-HEC3-FPC-_-_-_-
 X1 X2 X3

X1) Terminals:

Solder = S
 PCB Pin = P

X2) No. of Contacts:

3, 4, 5 or 8

X3) Housing Color:

Black = B
 Blue = BL
 Red = R
 Green = G

NOTES:

Rear Mount Adapter p/n PD-HEC3-RMA
 Front Mount Adapter p/n PD-HEC3-FMA

TOLERANCE
 UNLESS OTHERWISE SPECIFIED
 X ± 1
 X.X ± 0.4
 X.XX ± 0.13

Power Dynamics, Inc.

Phone: 973 560-0019 Whippany, New Jersey Fax: 973 560-0076

**PART: IP67 DUSTPROOF / WATERPROOF
 FEMALE SNAP LOCK PANEL CONNECTOR**

DRAWN BY	PB	DATE:	7/30/15
CHECK BY		DATE:	
APPR BY		DATE:	

PD-HE3-FPC-X-X-X		SHEET 1 of 1
PART #:		
SIZE: A	ALL DIMENSIONS FOR REFERENCE ONLY DIMENSIONS ARE IN MILLIMETERS	
SCALE: NTS		REV:

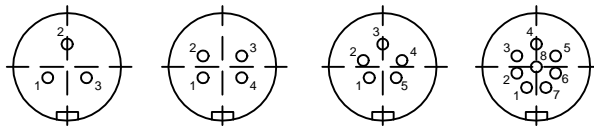

CONTACT ARRANGEMENT

REVISIONS	CHANGE	CHK	CHK	APPR
	REV	DATE		