

# NTC 规格书

Specification

客户名称

Customer name:

产品规格

Part No: NTC 10D-15

客户签名 <i>Customer Signature</i>	
日期 <i>Date</i>	

拟制 <i>Prepared</i>	审核 <i>Checked</i>	批准 <i>Approved</i>	日期 <i>Date</i>

## 1、产品特点 Feature of Power Thermistor

### 1.1 应用范围 Appliacion

- 转换电源, 开关电源, UPS 电源    ○Switching power-supply, switch power, ups power
- 镇流器及各类加热器                ○Electronic energy saving lamps electronic ballast and all kinds of electric heater
- 各类显像管, 显示器                ○All kinds of RT, display
- 电子节能灯, 其他照明灯具        ○Bulb and other lighting lamps

### 1.2 特点 Characteristic

- 体积小, 功率大, 抑制浪涌电流能力强    ○Small size, large power, strong capacity of suppression of inrush current
- 反应速度快                                    ○Fast response
- 材料常数 (B 值) 大, 残余电阻小        ○Big material constant (B value), small residual resistance
- 寿命长, 可靠性高                         ○Long life and high reliability
- 系列全, 应用范围宽                      ○Complete series, wide applications

## 2、产品代码 PART NUMBER

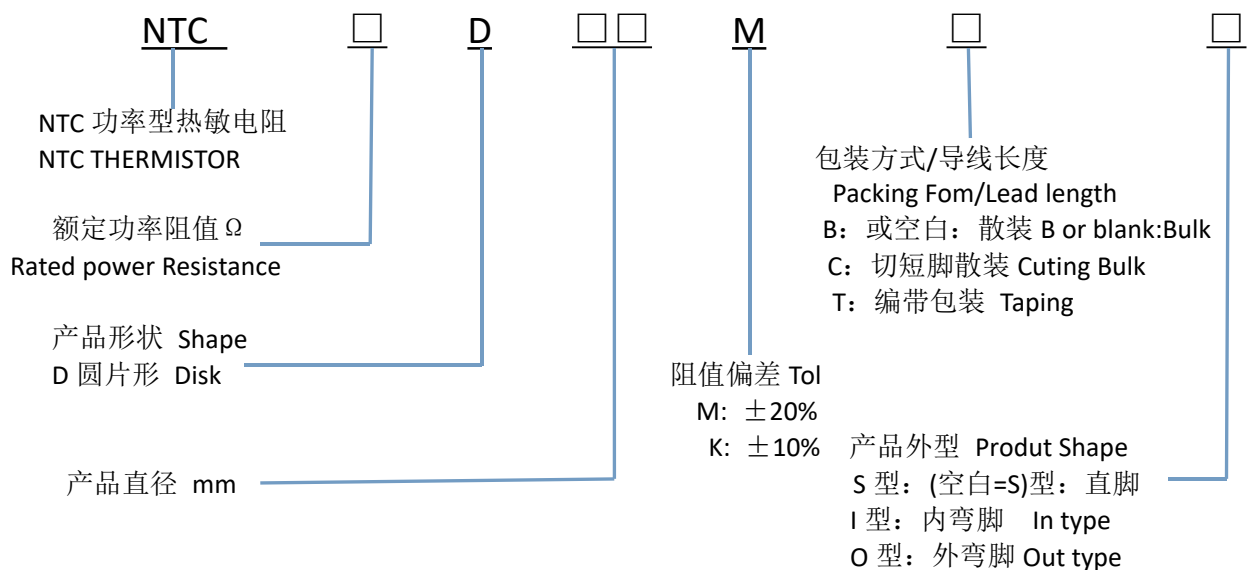

## 3、技术参数 technical parameters

型号 Part No	R <sub>25</sub> (Ω)	最大稳态电流 Max.steady State current (A)	残余电阻* Residual Resistance (Ω)	耗散系数* Dissipation factor (mw/°C)	热时间常数* Thermal time Constant (s)	工作温度 Operating Temperature (°C)
5D-5	5	1	0.35	6	20	-40+150
10D-5	10	0.7	0.77	6	20	
60D-5	60	0.5	1.88	6	18	
200D-5	200	0.1	18.70	6	18	
5D-7	5	2	0.28	10	30	
8D-7	8	1	0.54	9	28	
10D-7	10	1	0.62	9	27	
12D-7	12	1	0.82	9	27	
16D-7	16	0.7	1.00	9	27	
22D-7	22	0.6	1.11	9	27	
33D-7	33	0.5	1.49	10	28	
200D-7	200	0.2	11.65	11	28	
3D-9	3	4	0.12	11	35	
4D-9	4	3	0.19	11	35	
5D-9	5	3	0.21	11	34	
6D-9	6	2	0.32	11	34	
8D-9	8	2	0.40	11	32	
10D-9	10	2	0.46	11	32	
12D-9	12	1	0.66	11	32	

型号 Part No	R <sub>25</sub> (Ω)	最大稳态电流 Max.steady State current (A)	残余电阻* Residual Resistance (Ω)	耗散系数* Dissipation factor (mw/°C)	热时间常数* Thermal time Constant (s)	工作温度 Operating Temperature (°C)
16D-9	16	1	0.80	11	31	-40+175
20D-9	20	1	0.88	11	30	
22D-9	22	1	0.95	11	30	
33D-9	33	1	1.12	11	30	
50D-9	50	1	1.25	11	30	
80D-9	80	0.8	2.01	11	30	
120D-9	120	0.8	3.02	11	30	
200D-9	200	0.5	5.01	11	30	
2.5D-11	2.5	5	0.10	13	43	
3D-11	3	5	0.10	13	43	
4D-11	4	4	0.15	13	44	
5D-11	5	4	0.16	13	45	
6D-11	6	3	0.24	13	45	
8D-11	8	3	0.25	14	47	
10D-11	10	3	0.28	14	47	
12D-11	12	2	0.46	14	48	
16D-11	16	2	0.47	14	50	
20D-11	20	2	0.51	15	52	
22D-11	22	2	0.56	15	52	
30D-11	30	1.5	0.67	15	52	
50D-11	50	1.5	1.02	15	52	
60D-11	60	1.5	1.22	15	52	
80D-11	80	1.2	1.66	15	52	
1.3D-13	1.3	7	0.06	13	60	
2.5D-13	2.5	6	0.088	13	60	
3D-13	3	6	0.092	14	60	
4D-13	4	5	0.12	15	67	
5D-13	5	5	0.125	15	68	
6D-13	6	4	0.17	15	65	

型号 Part No	R <sub>25</sub> (Ω)	最大稳态电流 Max.steady State current (A)	残余电阻* Residual Resistance (Ω)	耗散系数* Dissipation factor (mw/°C)	热时间常数* Thermal time Constant (s)	工作温度 Operating Temperature (°C)
8D-13	8	4	0.194	15	65	-40+200
10D-13	10	4	0.206	15	65	
12D-13	12	3	0.316	16	65	
15D-13	15	3	0.335	16	65	
20D-13	20	3	0.372	16	65	
30D-13	30	2.5	0.517	16	65	
47D-13	47	2	0.81	17	65	
2.5D-15	2.5	8	0.071	18	76	
3D-15	3	7	0.075	18	76	
5D-15	5	6	0.112	20	76	
6D-15	6	5	0.155	20	80	
7D-15	7	5	0.173	20	80	
8D-15	8	5	0.178	20	80	
<b>10D-15</b>	<b>10</b>	<b>5</b>	<b>0.18</b>	<b>20</b>	<b>75</b>	
12D-15	12	4	0.25	20	75	
15D-15	15	4	0.268	21	85	
20D-15	20	4	0.288	17	86	
30D-15	30	3.5	0.438	18	75	
47D-15	47	3	0.68	21	86	
50D-15	50	3	0.72	21	86	
1.3D-20	1.3	9	0.037	24	113	
3D-20	3	8	0.055	24	113	
5D-20	5	7	0.087	23	112	
8D-20	8	6	0.142	25	115	
10D-20	10	6	0.162	24	113	
12D-20	12	5	0.195	24	114	
16D-20	16	5	0.212	25	113	

### 4.1、参数 (Common Parameters) : 引线图

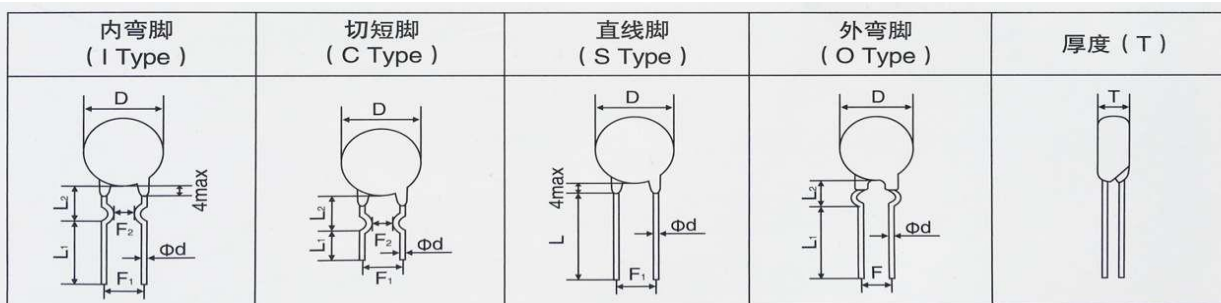

说明: 若非特别指出, 常用外形为内弯型长引线。

Note: if the particular shape, commonly used for bending type, namely the inner-bended forming for long lead

### 产品尺寸

尺寸 Dim (mm)	代号 Sym	Dmax	Tmax	Ød ±0.1	F1 ±1	F2 ±1.5	直引线 Straight Lead Wire		弯引线&直引线 Bend straight wirelead	
							Lmin	L1 ±0.5	L2 ±2	
型号 Part No										
NTC□D-5		7	5	0.55	5	3	15	3.5-20	7or4	
NTC□D-7		9	5	0.55	5	3	15	3.5-20	7or4	
NTC□D-9		11	5.5	0.75/0.55	7.5/5	5/3	15	3.5-20	7or4	
NTC□D-11		13	5.5	0.75	7.5/5	5/3	15	3.5-20	7or4	
NTC□D-13		15.5	6	0.75	7.5	5	15	3.5-20	7or4	
NTC□D-15		17.5	6	0.75	10/7.5	5	15	3.5-20	7or4	
NTC□D-20		22.5	7	1.0	10/7.5	/	15	/	/	

备注: □ 为额定零功率电阻值。

□ Rated zero-power resistance

#### (1) 引线形状 Lead the shape

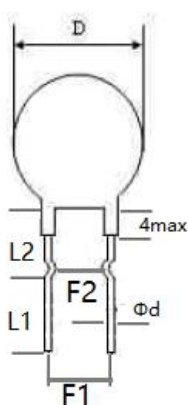

#### (2) 产品尺寸 Product size

型号	最大直径 Dmax	最大厚度 Tmax	引线直径 Ød ±0.1mm	间距 F1 ±1mm	间距 F2 ±1.5mm	引线长度 L1 ±0.5	引线长度 L2 ±2mm
10D-15	17.5mm	6mm	0.75mm	7.5mm	5.0mm	20mm	7or4

(3) 材料 (Materials)

- ①、封装材料 (Wrapper) : 酚醛树脂 (Modified phenolic resin)
- ②、引线 (Down-lead) : CP 线 (CP Wire)
- ③、颜色 (Coating color) : 黑色 (Black)

印字方式		
	NTC	负温度系数热敏电阻器 NTC thermistor
	10	额定零功率电阻值 10 Ω
	D	圆片型 Disk-Type
	15	直径 15±1 (mm)

4.2、主要技术参数 (Parameters of Technology) :

① 25℃时零功率电阻值 (Ω) ( Zero Power Resistance at 25℃) : 10±20%

② 热时间常数(S) (Thermal Time Constant): 75

③ 热耗散系数 (mW/℃) (Thermal Dissipation Constant ) : 20

④ 工作温度 (℃) (Operating Temperature) : -40~+200

⑤ 最大稳态电流(A) (Max Steady State Current) : 5

⑥ 最大允许使用容量值 (240Vac) : 470μF

Maximum allowable capacity value (240Vac) : 470μF

⑦ 绝缘电阻值 : >1000 MΩ, 将热敏电阻的引出端连接起来作为一个电极, 金属箔作为另一个电极, 在两电极间施加直流电压 100V±15V 测量两个电极间的绝缘电阻, 施加电压的时间为 1min, 绝缘电阻不小于 1000 MΩ;

Insulation resistance: 1000 MΩ ohm, the terminal of the thermistor connected as an electrode, metal foil as another electrode, 100V ± 15V DC voltage is applied between the two electrodes measure the insulation resistance between the two electrodes, the voltage applied to the time of 1min, the insulation resistance of not less than 1000 MΩ;

⑧ 耐电压 : 将热敏电阻的引出端连接起来作为一个电极, 金属箔作为另一个电极, 在两电极间施加一个频率为 40Hz-60Hz, 取规定绝缘电压 1.4 倍的 AC 电压 (AC500V) 为峰值电压, 持续时间为 60s±5s, 电压应近似于 100V / s 的速率逐步施加, 热敏电阻器

应无击穿或飞弧。

High voltage terminal: thermistor connected as an electrode, metal foil as another electrode in two electrode applied between a frequency of 40Hz-60Hz, AC voltage and insulation voltage of 1.4 times the provisions (AC500V) for the duration of the peak voltage, 60s + 5S, the rate of voltage should be similar to the 100V / s thermistor applied gradually, there should be no breakdown or arcing.

⑨ B 值 (K) (B Value) : 2950 ± 10%

用以下公式表示指数: Using the following formula

$$B = \left[ \frac{T_a \times T_b}{T_b - T_a} \right] \times \ln \left( \frac{R_a}{R_b} \right)$$

或者

$$B = 2.303 \times \left[ \frac{T_a \times T_b}{T_b - T_a} \right] \times \log \left( \frac{R_a}{R_b} \right)$$

公式中:

B-- 常数 (单位为 K) Constant (unit K)

R<sub>a</sub>-- 在温度 T<sub>a</sub> (单位为 K) 下测定的零功率电阻值 (单位为 Ω) ;

R<sub>b</sub>-- 在温度 T<sub>b</sub> (单位为 K) 下测定的零功率电阻值 (单位为 Ω) 。

T<sub>a</sub>=298.15K

T<sub>b</sub>=358.15K

B 值是材料系数或指热敏指数, B 值的大小由材料特性决定, B 值允许 ±5% 公差范围, 影响 B 值大小的因素属材料特性; B 值不同, 残余电阻大小不同, 持续工作时温升也不同; B 值越大, 残余电阻越小, 工作时温升越小。

B value is the material coefficient or thermal index, B value is decided by the size of the material properties, allowing the + 5% tolerance range of B value, B value influence the size of the material properties; the B values are different, the residual resistance of different sizes, continuous working temperature rise is also different; the bigger the B value, the residual resistance is small when the temperature rise is small.

## 5、热敏电阻选用原则 Principle of thermal resistor is chosen

### 5.1 热敏电阻的最大工作电流 > 回路的工作电流

Thermistor maximum operating current > loop operating current



## 5.2 热电阻的标称电阻值 $R \geq 1.414 * E / I_m$

Nominal resistance values of thermal resistance  $R \geq 1.414 * E / I_m$

E 为线路电压 E is the line voltage  $I_m$  为浪涌电流  $I_m$  a surge current 一般来讲对于开关电源 转换电源 不间断电源 逆变电源等  $I_m=100$  倍工作电流对于灯丝加热器等的电路  $I_m=30$  倍工作电流

In general, the switching power supply, switching power supplies, uninterruptible power supplies, power inverter and other times operating current  $I_m = 100$  For the filament heater circuit like  $I_m = 30$  times the operating current.

## 5.3 B 值越大，残余电阻越小，工作时温升越小。

B The larger the value, the smaller the residual resistance, the smaller the temperature rise during operation.

## 5.4 热时间常数和耗散系数两者为互为依赖的关系，并不是说某一个数值越大越好或越小越好，而是两者的乘积越大说明热敏电阻的热容量就越大，那么抗浪涌电流的能力就越强。

Thermal time constant and dissipation factor as both mutually dependent relationship, not to say that one or the greater the value, the better the smaller the better, but the product of the two greater the heat capacity of the thermistor greater, then resistance to surge current, the stronger

## 5.5 热敏电阻用于电源电路时主要是用来抑制开机时的大浪涌电流，大的浪涌电流是电容放电产生，所以电路中所要安装的滤波储能电容的选配也是很关键的一个条件，为确保热敏电阻器能够安全的起到保护电路的作用，所以要求电源设计厂家也应该充分考虑这一因素。

When the power supply circuit for the thermistor is mainly used to suppress large inrush current at power-on, a large inrush current is the capacitor discharge, the filter to be

installed in the tank circuit capacitance matching is a very critical condition to ensure that the thermistor circuit can play a role in security protection, so the powersupply design requirements for manufacturers should also take full account of this factor.

5.6 通过电路中的最大工作电压和最大启动电流等参数可以利用公式  $R=U/I$  计算出电阻值范围。

Through the circuit maximum operating voltage and maximum starting current and other parameters can use the formula  $R = U / I$  calculated the resistance value range.

5.7 以上这些选用原则可以锁定出 NTC 热敏电阻的对应型号，如果贵司有特殊设计需要可与我司技术部洽谈。

These principles may choose to lock the NTC thermistor corresponding model, if your company has special design needs with our technical department to discuss.

## 6、存储条件 **Storage condition**

### 6.1 存贮环境条件

温度 Temperature	-10°C ~ +40°C
湿度 Humidity	≤70%RH
期限 Term	≤6 months (先进先出 First-in/ First-out)
地点 Place	<p>1. 不要暴露在下列环境条件下，否则将导致性能衰退或参数漂移 <i>Do not exposing the components to the following conditions, otherwise, it may result in deterioration of characteristics</i></p> <p>2. 腐蚀性或易氧化气体 <i>Corrosive gas or deoxidizing gas</i></p> <p>3. 易燃易爆气体 <i>Flammable and explosive gases</i></p> <p>4. 油、水和化学溶液 <i>Oil, water and chemical liquid</i></p> <p>5. 太阳光下 <i>Under the sunlight</i></p>

6.2 请不要在下列条件下使用本元件，否则将可能导致性能衰退或产品损毁，甚至引起火灾。

**Do not apply the components under the following conditions, otherwise, it may result in deterioration of characteristics, destruction of components or in the worst case, to catching fire**

6.2.1 超过最大的工作电流 **Exceeding I<sub>max</sub>**

6.2.2 超过许可工作温度范围 **Exceeding rated temperature range**

6.2.3 散热不良，由于散热不良，本元件可能因部分过热而导致破坏

**Inferior thermal dissipation, Due to badly inferior thermal dissipation, some part of the components body will become overheated and then be damaged**

## 7、产品性能 **properties of products**

### 7.1 机械性能 **Mechanical Characteristics**

机械性能 <b>MECHANICAL CHARACTERISTICS</b>		
指标项目 Item	技术要求 Specification	测试条件/方法 Test Conditions & Methods
可焊性 Solder-ability	浸润部分上锡均匀，上锡面积≥95% The terminals shall be uniformly tinned, and its area≥95%	将引出端沾助焊剂后，浸入到温度为240-245℃、深度为15mm 的锡槽中锡面距NTC 本体下端6mm 处，持续2-3秒。（参见IEC68-2-20 /GB2423.28 试验Ta） Dipping the NTC terminals to a depth of 15mm in a soldering bath of 240-245℃ and to the place of 6mm far from NTC body for 2-3s (See IEC68-2-20 /GB2423.28 Ta)
耐焊接热 Resistance To Soldering Heat	无可见损伤 No visible mechanical damage. $\Delta R/R_N \leq 20\%$ ( $\Delta R =  R_N - R_N' $ )	根据IEC68-2-20 (GB2423 .28) 试验Tb 进行试验。 采用焊槽法，将引出端沾助焊剂后，浸入到温度为265±5℃、深度为15mm 的锡槽中，锡面距NTC 本体下端6mm 处，维持10±1 秒。在25±2℃条件下恢复4-5h 后，复测额定零功率电阻R <sub>N'</sub> 。 Dipping the NTC terminals to a depth of 15mm in a soldering bath of 265±5℃ and to the place for 6mm below from NTC body for 10±1s. After recovering 4-5h under 25±2℃. The rated zero power resistance value R <sub>N'</sub> shall be measured. (See IEC68-2-20 /GB2423.28 Tb)
引出端强度 Strength of lead terminal	无损坏 No break out $\Delta R/R_N \leq 20\%$ ( $\Delta R =  R_N - R_N' $ )	根据IEC68-2-21 (GB2423 .29) 试验U 进行试验。 试验Ua: 拉力10N，持续10 S； 试验Ub: 弯曲90°，拉力5N，持续10 S； 扭转180°，拉力5N，持续10 S。 在25±2℃条件下恢复4~5 h 后，复测额定零功率电阻R <sub>N'</sub> 。 Fasten the body and apply a force gradually to each lead until 10N and then keep for 10sec, Hold body and apply a force to each lead until 90° slowly at 5N in the direction of lead axis and then keep for 10sec, and do this in the opposite direction repeat for other terminal. After recovering 4~5h under 25±2℃, the rated zero power resistance value R <sub>N'</sub> shall be measured. (See IEC68-2-21/GB2423.29 Ua / Ub)

## 7.2 电气性能 Electrical Characteristics

电气性能 ELECTRICAL CHARACTERISTICS		
测试条件/方法 Test Conditions & Method		
指标项目 Item	技术要求 Specification	测试条件/方法 Test Conditions & Methods
额定零功率电阻 Rated Zero-Power Resistance $R_N (\Omega)$	$20 \pm 20\%$	环境温度 $T_A$ : $25^\circ\text{C} \pm 1^\circ\text{C}$ 测试电压: $1.5\text{V}_{\text{DC}}$ 在恒温 $T_A$ 条件下, 放置1~2 小时后测得阻值 $R_N$ 。 Ambient temp. Range: $25^\circ\text{C} \pm 1^\circ\text{C} (T_A)$ . Testing voltage: $1.5\text{V}_{\text{DC}}$ After placing for 1~2 hours under $T_A$ , the resistance value shall be measured
热耗散系数 $\delta$ (mW/°C) Thermal Dissipation Constant	$\geq 18$	在特定的环境温度下, 热耗散系数( $\delta$ )为热敏电阻电功率消耗( $\Delta P$ )与本体温度变化量( $\Delta T$ )的比值。 The thermal dissipation constant( $\delta$ ) could be calculated by the ratio of a change in power dissipation( $\Delta P$ ) of the thermistor to a change in temperature( $\Delta T$ ) of the thermistor at a specified ambient temperature
热时间常数 $\tau$ (s) Thermal Time Constant	$\leq 85$	热时间常数( $\tau$ )为在零功率条件下, 热敏电阻的温度下降到其最初温度与最终温度之差为63.2% 时所需要的时间 The time( $\tau$ ) shall be measured within which the temperature change of NTC thermistor is reached at 63.2% of the ambient temperature change under zero power condition
材料常数 Material Constant B	$2950 \pm 10\%$ $B = T_1 T_2 / (T_2 - T_1) \times \ln(R_1 / R_2)$	$R_1, R_2$ 分别为 $T_1, T_2$ 温度下的零功率电阻 $R_1, R_2$ is zero-power resistance at $T_1, T_2$ $T_1 = 298.15 \text{ K}(25^\circ\text{C})$ $T_2 = 323.15 \text{ K}(50^\circ\text{C})$
最大稳态电流 (A) Max. Steady State Current	无可见损伤 visible mechanical damage. $\Delta R_N / R_N \leq 20\%$ ( $\Delta R =  R_N - R_N' $ )	环境温度: $25^\circ\text{C} \pm 2^\circ\text{C}$ Ambient temp. Range. 测试电流: $4.0\text{A}$ Testing Current

## 7.3 可靠性试验 Reliability Test

可靠性试验（周期性检测项目） Reliability Test		
指标项目 Item	技术要求 Specification	测试条件/方法 Test Conditions & Methods
温度循环测试 Temp. Cycling Testing	无可见损伤 No visible mechanical damage. $\Delta R_N / R_N \leq 20\%$ $(\Delta R =  R_N - R_N' )$	在 $T_a = -40 \pm 3^\circ\text{C}$ 和 $T_b = 200 \pm 3^\circ\text{C}$ 的环境温度中各存放30分钟,循环5次.每次高低温循环都有在 $25 \pm 2^\circ\text{C}$ 的环境中过渡5分钟。样品进行温度循环测试后,取出放置室温 ( $25 \pm 2^\circ\text{C}$ ) 4~5 小时后测量零功率电阻 $R_N'$ 。 $T_a: -40 \pm 3^\circ\text{C} / 30\text{min} \rightarrow 25 \pm 2^\circ\text{C} / 5\text{min} \rightarrow T_b: 200 \pm 3^\circ\text{C} / 30\text{min} \rightarrow 25 \pm 2^\circ\text{C} / 5\text{min}$ Cycles: 5times After recovering 4~5 h under $25 \pm 2^\circ\text{C}$ , the rated zero power resistance value $R_N'$ shall be measured.
电循环测试 Electrical Cycling Testing	无可见损伤 No visible mechanical damage. $\Delta R_N / R_N \leq 20\%$ $(\Delta R =  R_N - R_N' )$	环境温度: $25^\circ\text{C} \pm 2^\circ\text{C}$ . 循环次数: 1,000 次 通/断: 1 分钟/ 5 分钟 测试电流:4.0A 样品置于室温 ( $25 \pm 2^\circ\text{C}$ ) 4~5 小时后,测量其零功率电阻 $R_N'$ 。 Ambient temp. Range: $25^\circ\text{C} \pm 2^\circ\text{C}$ . Cycles: 1,000times On / Off: 1m / 5m Test Current 4.0A After recovering 4~5h under $25 \pm 2^\circ\text{C}$ , the rated zero power resistance value $R_N'$ shall be measured.
持久性测试 LoadLife ( Endurance ) Testing	无可见损伤 No visible mechanical damage. $\Delta R_N / R_N \leq 20\%$ $(\Delta R =  R_N - R_N' )$	环境温度: $25^\circ\text{C} \pm 2^\circ\text{C}$ .样品通过最大工作电流 4.0A ,1,000±24 小时后,取出置于室温 ( $25 \pm 2^\circ\text{C}$ ) 4~5 小时后,测量其零功率电阻 $R_N'$ 。 Ambient temp. Range: $25^\circ\text{C} \pm 2^\circ\text{C}$ ; 4.0A/ 1,000 ±24h After recovering 4~5 h under $25 \pm 2^\circ\text{C}$ , the rated zero power resistance value $R_N'$ shall be measured.
耐湿性测试 Humidity Testing	无可见损伤 No visible mechanical damage. $\Delta R_N / R_N \leq 20\%$ $(\Delta R =  R_N - R_N' )$	在温度 $40 \pm 2^\circ\text{C}$ ,相对湿度 $93 \pm 3\%$ 的环境中放置 $1000 \pm 24$ 小时后,取出置于室温 ( $25 \pm 2^\circ\text{C}$ ) 4~5 小时后,测量其零功率电阻 $R_N'$ 。 Ambient temp. range : $40^\circ\text{C} \pm 2^\circ\text{C}$ R.H.: $93 \pm 3\%$ , Energized time: $1000 \pm 24$ h After recovering 4~5 h under $25 \pm 2^\circ\text{C}$ , the rated zero power resistance value $R_N'$ shall be measured

8、电压-电流关系曲线 **Graph of Voltage vs. Current**

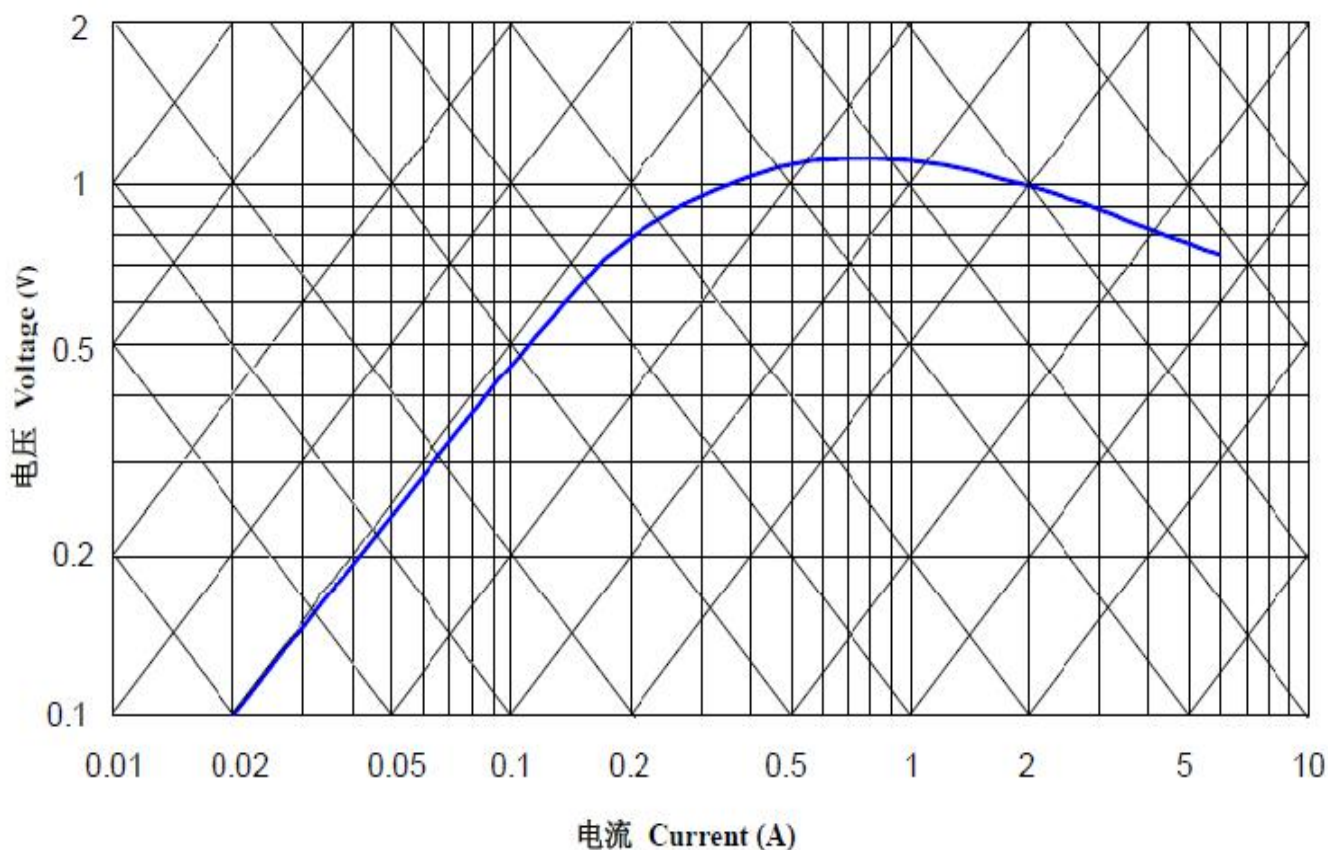

9、产品特性曲线 **Graph of Characteristics**

9.1 电阻-温度关系曲线 **Graph of Resistance vs. Temperature**

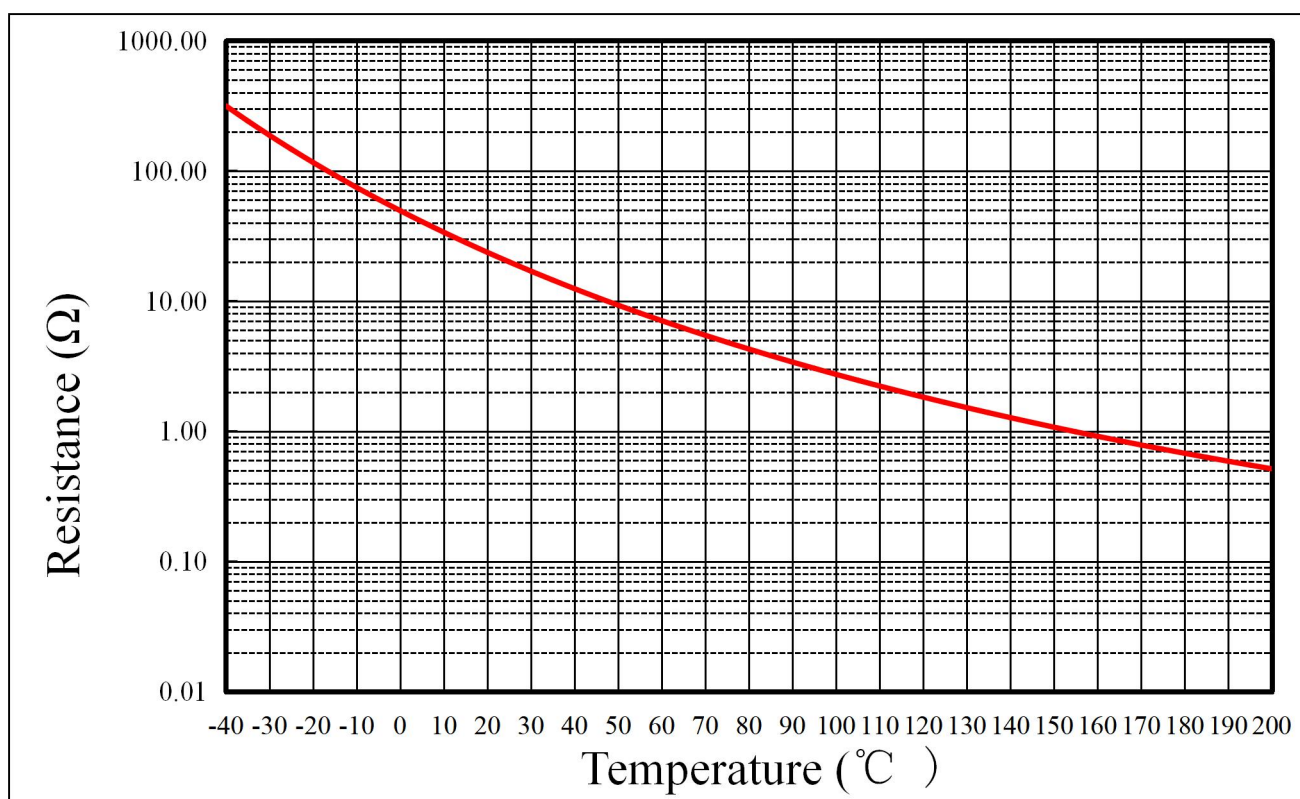

**9.1.1 R-T chart 阻温特性表**

Temp °C	Resistance Ω			Temp °C	Resistance Ω		
	max	center	min		max	center	min
-40.0	191.56	315.51	498.87	-19.0	74.76	110.91	157.96
-39.0	182.47	298.91	470.08	-18.0	71.76	105.98	150.25
-38.0	173.88	283.32	443.18	-17.0	68.90	101.30	142.97
-37.0	165.76	268.66	418.02	-16.0	66.18	96.86	136.10
-36.0	158.08	254.87	394.49	-15.0	63.59	92.65	129.60
-35.0	150.82	241.90	372.46	-14.0	61.11	88.66	123.47
-34.0	143.95	229.69	351.83	-13.0	58.75	84.86	117.67
-33.0	137.45	218.19	332.51	-12.0	56.50	81.25	112.18
-32.0	131.29	207.36	314.39	-11.0	54.35	77.83	106.98
-31.0	125.46	197.14	297.39	-10.0	52.30	74.57	102.07
-30.0	119.92	187.51	281.45	-9.0	50.34	71.47	97.41
-29.0	114.68	178.42	266.47	-8.0	48.47	68.52	93.00
-28.0	109.70	169.84	252.41	-7.0	46.68	65.72	88.82
-27.0	104.98	161.73	239.20	-6.0	44.97	63.05	84.86
-26.0	100.50	154.08	226.77	-5.0	43.33	60.50	81.10
-25.0	96.24	146.84	215.09	-4.0	41.77	58.08	77.54
-24.0	92.20	140.00	204.09	-3.0	40.27	55.77	74.15
-23.0	88.35	133.53	193.73	-2.0	38.83	53.57	70.94
-22.0	84.69	127.40	183.98	-1.0	37.46	51.47	67.89
-21.0	81.22	121.60	174.79	0.0	36.15	49.47	64.99
-20.0	77.91	116.11	166.13	1.0	34.89	47.56	62.23

9.1.2 R T chart 阻温特性表

Temp °C	Resistance Ω			Temp °C	Resistance Ω		
	max	center	min		max	center	min
2.0	33.68	45.73	59.61	23.0	16.99	21.38	25.83
3.0	32.53	43.99	57.12	24.0	16.49	20.68	24.90
4.0	31.42	42.33	54.75	25.0	16.00	20.00	24.00
5.0	30.35	40.74	52.49	26.0	15.43	19.35	23.30
6.0	29.33	39.22	50.34	27.0	14.88	18.72	22.62
7.0	28.35	37.77	48.30	28.0	14.36	18.12	21.96
8.0	27.41	36.38	46.35	29.0	13.85	17.54	21.33
9.0	26.51	35.05	44.49	30.0	13.37	16.99	20.72
10.0	25.64	33.78	42.72	31.0	12.91	16.45	20.13
11.0	24.81	32.56	41.03	32.0	12.46	15.94	19.57
12.0	24.01	31.40	39.42	33.0	12.04	15.44	19.02
13.0	23.24	30.29	37.88	34.0	11.63	14.97	18.49
14.0	22.50	29.22	36.42	35.0	11.24	14.51	17.98
15.0	21.79	28.19	35.01	36.0	10.86	14.06	17.48
16.0	21.11	27.21	33.68	37.0	10.50	13.64	17.01
17.0	20.45	26.27	32.40	38.0	10.15	13.23	16.54
18.0	19.82	25.37	31.18	39.0	9.82	12.83	16.10
19.0	19.21	24.51	30.01	40.0	9.50	12.45	15.67
20.0	18.62	23.68	28.90	41.0	9.19	12.08	15.25
21.0	18.06	22.88	27.83	42.0	8.90	11.73	14.85
22.0	17.52	22.12	26.81	43.0	8.61	11.39	14.46



**9.1.3 R-T chart 阻温特性表**

Temp °C	Resistance Ω			Temp °C	Resistance Ω		
	max	center	min		max	center	min
44.0	8.34	11.06	14.08	65.0	4.42	6.20	8.37
45.0	8.07	10.74	13.71	66.0	4.29	6.05	8.18
46.0	7.82	10.43	13.36	67.0	4.17	5.89	7.99
47.0	7.57	10.13	13.02	68.0	4.06	5.75	7.81
48.0	7.34	9.85	12.68	69.0	3.95	5.60	7.64
49.0	7.11	9.57	12.36	70.0	3.84	5.46	7.47
50.0	6.89	9.30	12.05	71.0	3.74	5.33	7.30
51.0	6.68	9.04	11.75	72.0	3.63	5.20	7.14
52.0	6.48	8.79	11.46	73.0	3.54	5.07	6.98
53.0	6.29	8.55	11.17	74.0	3.44	4.95	6.83
54.0	6.10	8.32	10.90	75.0	3.35	4.83	6.68
55.0	5.92	8.09	10.63	76.0	3.26	4.71	6.54
56.0	5.74	7.88	10.37	77.0	3.18	4.60	6.40
57.0	5.57	7.67	10.12	78.0	3.10	4.49	6.26
58.0	5.41	7.46	9.88	79.0	3.02	4.39	6.13
59.0	5.25	7.26	9.65	80.0	2.94	4.28	6.00
60.0	5.10	7.07	9.42	81.0	2.86	4.18	5.87
61.0	4.95	6.89	9.20	82.0	2.79	4.09	5.75
62.0	4.81	6.71	8.98	83.0	2.72	3.99	5.63
63.0	4.68	6.54	8.77	84.0	2.65	3.90	5.51
64.0	4.54	6.37	8.57	85.0	2.58	3.81	5.40

9.1.4 R-T chart 阻温特性表

Temp °C	Resistance Ω			Temp °C	Resistance Ω		
	max	center	min		max	center	min
86.0	2.52	3.73	5.29	108.0	1.50	2.32	3.45
87.0	2.46	3.64	5.18	109.0	1.46	2.27	3.39
88.0	2.40	3.56	5.08	110.0	1.43	2.23	3.33
89.0	2.34	3.48	4.97	111.0	1.40	2.18	3.27
90.0	2.28	3.40	4.88	112.0	1.37	2.14	3.21
91.0	2.23	3.33	4.78	113.0	1.34	2.10	3.15
92.0	2.17	3.26	4.68	114.0	1.31	2.06	3.10
93.0	2.12	3.18	4.59	115.0	1.28	2.02	3.04
94.0	2.07	3.12	4.50	116.0	1.26	1.98	2.99
95.0	2.02	3.05	4.41	117.0	1.23	1.94	2.94
96.0	1.97	2.98	4.33	118.0	1.20	1.90	2.89
97.0	1.93	2.92	4.25	119.0	1.18	1.87	2.84
98.0	1.88	2.86	4.16	120.0	1.15	1.83	2.79
99.0	1.84	2.80	4.09	121.0	1.13	1.80	2.74
100.0	1.80	2.74	4.01	122.0	1.11	1.76	2.70
101.0	1.75	2.68	3.93	123.0	1.08	1.73	2.65
102.0	1.71	2.62	3.86	124.0	1.06	1.70	2.61
103.0	1.67	2.57	3.79	125.0	1.04	1.67	2.56
104.0	1.64	2.52	3.72	126.0	1.02	1.64	2.52
105.0	1.60	2.47	3.65	127.0	1.00	1.61	2.48
106.0	1.56	2.42	3.58	128.0	0.98	1.58	2.44
107.0	1.53	2.37	3.52	129.0	0.96	1.55	2.40

**9.1.5 R-T chart 阻温特性表**

Temp°C	Resistance Ω			Temp°C	Resistance Ω		
	max	center	min		max	center	min
130.0	0.94	1.52	2.36	153.0	0.61	1.02	1.65
131.0	0.92	1.49	2.32	154.0	0.60	1.01	1.63
132.0	0.90	1.47	2.28	155.0	0.59	0.99	1.61
133.0	0.89	1.44	2.25	156.0	0.58	0.98	1.58
134.0	0.87	1.41	2.21	157.0	0.57	0.96	1.56
135.0	0.85	1.39	2.18	158.0	0.56	0.95	1.54
136.0	0.84	1.37	2.14	159.0	0.55	0.93	1.52
137.0	0.82	1.34	2.11	160.0	0.54	0.92	1.50
138.0	0.80	1.32	2.08	161.0	0.53	0.90	1.47
139.0	0.79	1.30	2.04	162.0	0.52	0.89	1.45
140.0	0.77	1.27	2.01	163.0	0.51	0.87	1.43
141.0	0.76	1.25	1.98	164.0	0.50	0.86	1.41
142.0	0.74	1.23	1.95	165.0	0.49	0.85	1.39
143.0	0.73	1.21	1.92	166.0	0.49	0.83	1.38
144.0	0.72	1.19	1.89	167.0	0.48	0.82	1.36
145.0	0.70	1.17	1.86	168.0	0.47	0.81	1.34
146.0	0.69	1.15	1.84	169.0	0.46	0.80	1.32
147.0	0.68	1.13	1.81	170.0	0.45	0.79	1.30
148.0	0.67	1.11	1.78	171.0	0.45	0.77	1.29
149.0	0.65	1.09	1.75	172.0	0.44	0.76	1.27
150.0	0.64	1.08	1.73	173.0	0.43	0.75	1.25
151.0	0.63	1.06	1.70	174.0	0.43	0.74	1.23
152.0	0.62	1.04	1.68	175.0	0.42	0.73	1.22

## 10、产品标志说明

### 中性标志 The neutral marks

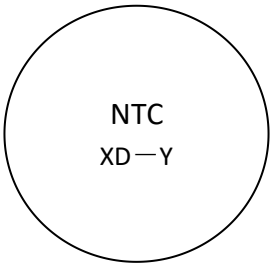
	NTC	负温度系数热敏电阻器 NTC thermistor
	X	额定零功率电阻值 Rated ZeroPower Resistance
	D	圆片型 Disk-Type
	Y	最大芯片直径 Max diameter of disk (mm)

以上所有类型标志统称圆片型，生产以中性标志为主，如有特殊要求请与我们的销售人员联系，产品规格与数据若有变更，恕不另行通知

All of the above types of marks round, mainly in the production of neutral markers, if you have special request, please contact our sales staff, for product specification and data are subject to change without notice

## 11、包装 Packing

### 11.1.1 散装式样 BULK STYLE

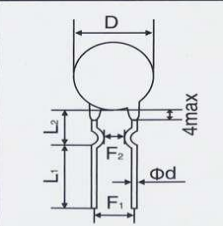
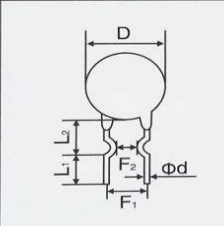
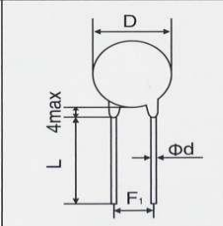
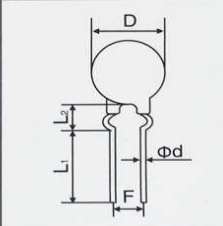
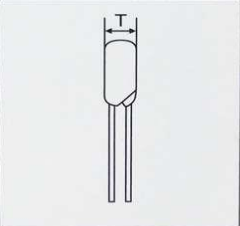
内弯脚 (I Type)	切短脚 (C Type)	直线脚 (S Type)	外弯脚 (O Type)	厚度 (T)
				
<p><b>说明:</b> 若非特别指出，常用外形为内弯型长引线。  <b>Note:</b> if the particular shape, commonly used for bending type, namely the inner-bended forming for long lead</p>				

11.1.2 散装包装式样 Bulk/Packing Style ①、常规产品包装 Normal product packaging

规格 Dimension	一袋 Bag	内盒 Inside the box	外箱 carton
NTC□D-5	1000 pcs	3000 pcs	18000 pcs
NTC□D-7	1000 pcs	3000 pcs	18000 pcs
NTC□D-9	500 pcs	2000 pcs	12000 pcs
NTC□D-11	500 pcs	1500 pcs	9000 pcs
NTC□D-13	250 pcs	1000 pcs	6000 pcs
NTC□D-15	250 pcs	1000 pcs	6000 pcs
NTC□D-20	100 pcs	400 pcs	2400 pcs

②、切脚产品包装 Cut the feet product packaging

规格 Dimension	一袋 Bag	内盒 Inside the box	外箱 carton
NTC□D-5	1000 pcs	8000 pcs	48000 pcs
NTC□D-7	1000 pcs	5000 pcs	30000 pcs
NTC□D-9	1000 pcs	4000 pcs	24000 pcs
NTC□D-11	1000 pcs	3000 pcs	18000 pcs
NTC□D-13	500 pcs	2000 pcs	12000 pcs
NTC□D-15	500 pcs	1000 pcs	6000 pcs

11.2 编带数量 Tape number

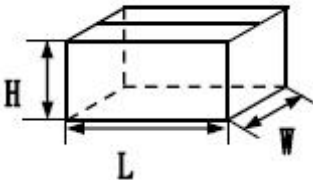
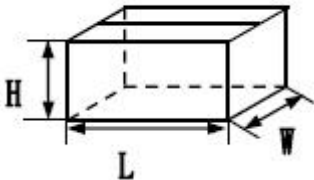
产品包装 Product ackaging	内盒 Inside the box		外箱 carton	
编带 Taping	 335*265*45 (L*W*H)		 540*360*295 (L*W*H)	
	产品数量 (只) product quantity(pieces)	1000	产品数量 (只) product quantity(pieces)	12000

### 11.3 编带包装式样 **Packing style**

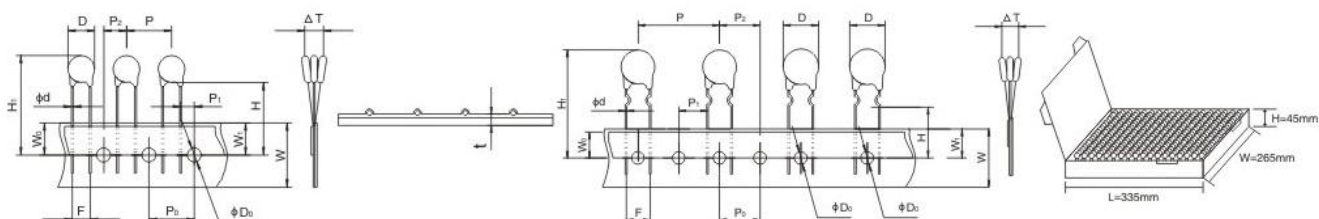

### 11.4 编带尺寸 **Tape size**

名称 Description	符号 Symbol	产品直径 Dimension					
		Ø5	Ø7	Ø9-Ø11	Ø13	Ø15	Ø20
编带间距 Taping pitch	P ±1	12.7	12.7	25.4	25.4	30	30
输送孔间距 Feed hole pitch	P0 ±1	12.7	12.7	12.7	12.7	15	15
对输送孔的偏 Feed hole off alignment	P1 ±0.7	3.85	3.85	8.95	8.95	11.25	10.0
	P2 ±1.3	12.7	12.7	12.7	12.7	15	15
底部高度 Bottom height	H ±1.0	20	20	21	24.5	23.5	21
顶部高度 Top height	H1 max	29.0	32.0	36.0	40	40	48.0
载带宽度 Carrier tape width	W ±1.0	18	18	18	18	18	18
胶带宽度 Adhesive tape width	W0 max	8.0	8.0	8.0	8.0	8.0	8.0
对输送孔的高度偏移 Feed hole height off alignment	W1 ±0.5	9.0	9.0	9.0	9.0	9.0	9.0
输送孔直径 Feed hole diameter	ØD0 ±0.3	4.0	4.0	4.0	4.0	4.0	4.0

本体直径 Body diameter	D max	7.5	9.0	13.5	18.0	18.0	23.0
引线直径 Wire lead diameter	Ød ±0.03	Ø0.55	Ø0.55	Ø0.75	Ø0.75	Ø0.97	Ø0.97
产品在胶带上偏差 Deviation across tape	ΔT max	2.0	2.0	2.0	2.0	2.0	2.0
编带总厚度 Overall tape thickness	t ±0.2	0.7	0.7	0.7	0.7	0.7	0.7
引线间距 Lead spacing	F ±1.0	5.0	5.0	7.5	7.5	10.0	10.0

## 12 NTC 热敏电阻注意事项 NTC thermistor to use matters needing attention

请遵循以下事项，否则可能会造成 NTC 热敏电阻损坏，使用设备损伤或引起误动作等后果

Please follow the following, or may result in damage to the NTC thermistor, the use of equipment damage or cause false action, etc.

①、请勿在使用温度范围以外使用，请勿施加超出使用温度范围上下限的急剧温度变化。

Please follow the following, or may result in damage to the NTC thermistor, the use of equipment damage or cause false action, etc.

②、请在额定功率条件下使用 NTC 热敏电阻。各规格最大额定功率为 Φ7—1.2W Φ9—1.9W Φ11—2.3W Φ13—3W Φ15—3.5W Φ20—4W

Please use the NTC thermistor under the rated power. The maximum rated power of each specification is Phi 7 Phi 9 - 1.2W - 1.9W 11 - 2.3W 13 - Phi Phi Phi Phi 20 3W 15 - 3.5W - 4W

③、在高湿高温环境下使用护套型 NTC 热敏电阻时应采取仅使护套封闭部分暴露于环境（水中 湿气）中，而护套开口部分不会直接接触到水及蒸汽的设计

In the high humidity and high temperature environment, the sheath type NTC thermal resistance should be used only to expose the sealing part of the sheath to the environment (moisture in water), and the opening part of the sheath will not be directly exposed to the design of water and steam.

④、配线时应确保导线端部（含连接器）不会深入水. 蒸汽. 电解质液等否则会造成接触不良。

Wiring should ensure that the end of the wire (including connectors) will not be deep water. Steam. Electrolyte solution, etc., will result in poor contact.

⑤、请勿在腐蚀性气体的环境（Cl<sub>2</sub>. NH<sub>3</sub>. SO<sub>x</sub>. NO<sub>x</sub>）以及会接触到电解质液. 盐水. 酸. 碱. 有机溶剂的场所中使用。

Please do not be exposed to the corrosive gas environment (. NH<sub>3</sub>. SO<sub>x</sub>. NO<sub>x</sub> Cl<sub>2</sub>) and will be exposed to the electrolyte solution.

⑥、请勿过度拉伸及弯曲导线，请勿施加过度的振动. 冲击及压力

Do not over stretch and bend the wire, please do not exert excessive vibration.

⑦、金属腐蚀可能会造成设备功能故障，故在选择材质时应确保金属护套型及螺钉紧固型 NTC 热敏电阻与安装的金属件之间不会产生接触的电位差。

Metal corrosion may cause equipment fault, so make sure not between metal metal support and screw fastening type NTC thermistor and installation of the contact potential difference in the choice of materials.

- ⑧、功率型 NTC 周围应避免安装发热和易燃元件，建议选用弯脚上部引线较高的产品，使 NTC 热敏电阻在线路板上高出其它元件，以免发热影响其它元件正常工作。

Around the power type NTC should be avoided to install heat and flammable components, recommended products with higher bending the upper lead, the NTC thermistor on the circuit board is higher than other elements, so as not to affect the normal work of other heating element.

- ⑨、NTC 热敏电阻是按不同的功能用途分别进行设计的,如有疑问可与我司联络。

NTC thermistor is designed according to different functions, such as the question can contact with me.