

Resistive touch screen controller LSI series for Automotive

4-wire Resistive Touch Screen Controller

BU21028FV-M

General Description

Unlike most resistive touch screen controllers, the BU21028FV-M 4-wire resistive touch-screen controller can generate data that enables dual touch detection. The Host processor can use this data to detect single and dual point coordinates.

Features

- AEC-Q100 (Note 1)
 - standard 4-wire resistive touch screens
 - Single and dual touch detection
 - I2C-like interface (for the host processor I/F)
 - 12-bit resolution
 - Single 2.7V to 3.6V power supply
 - Auto power down/on control
 - Built-in clock oscillator circuit
- (Note1: Grade 3)

Key Specifications

- Power supply voltage: 2.7V to 3.6V
- Temperature range: -40°C to +85°C
- Standby current: 1.0 μA(Max)
- Sleep current: 100 μA(Max)
- Operating current: 0.8 mA(Typ)
- Coordinate resolution: 12bit

Package(s)
SSOP-B20

W(Typ) x D(Typ) x H(Max)
6.50 mm x 6.40 mm x 1.15 mm



Applications

- Equipment with built-in user interface for 4-wire resistive touch screen
- Portable information equipment like smart phones, tablets, and PDAs
- PCs or peripheral equipment like laptops, touch screen monitors, and printers
- audioIn-vehicle terminals such as car navigation system, car audio system and display audio systems

Typical Application Circuit(s)

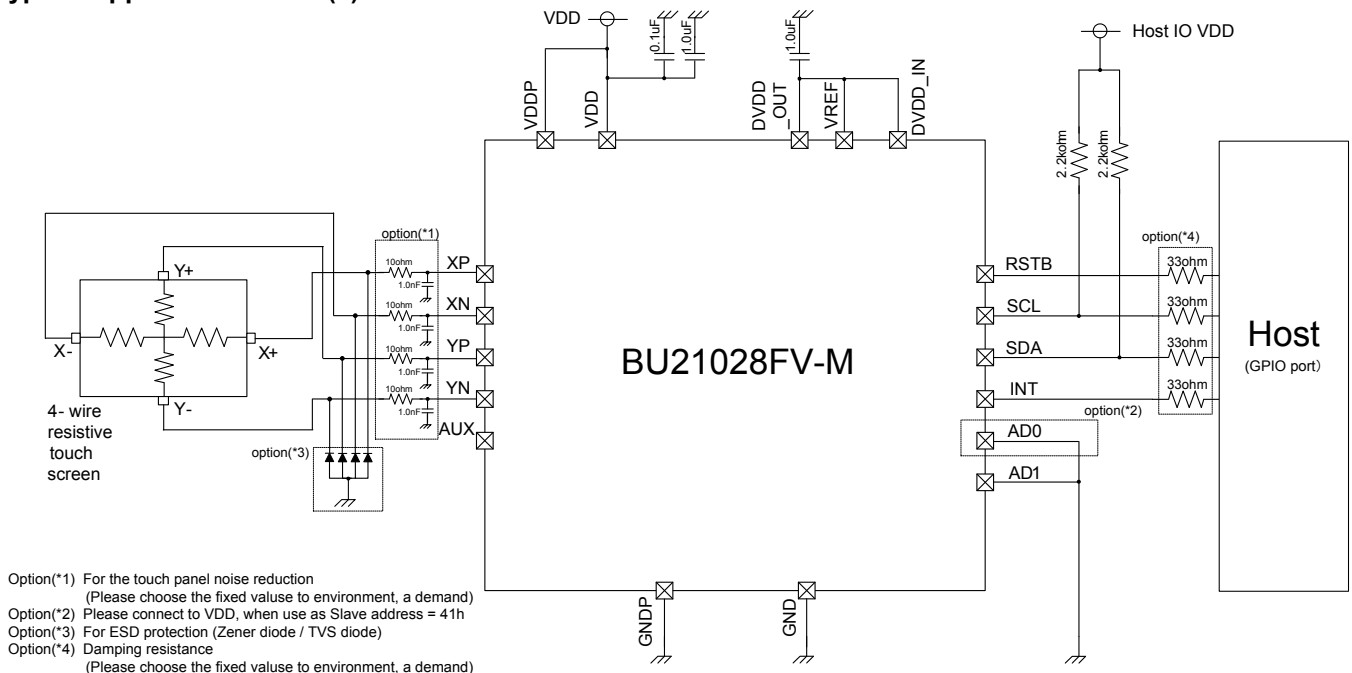

○Product structure : Silicon monolithic integrated circuit ○This product has no designed protection against radioactive rays

Contents

General Description	1
Features.....	1
Applications	1
Key Specifications.....	1
Package(s).....	1
Typical Application Circuit(s)	1
Pin Configuration(s)	3
Pin Description(s)	3
Equivalent Circuit.....	3
Block Diagram(s)	4
OVERVIEW	4
Absolute Maximum Ratings	5
Thermal Resistance ^(Note 1)	5
Recommended Operating Conditions	6
Electrical Characteristics.....	6
Host interface AC timing	7
Host Interface Specification	8
Power Supply and Reset Timing Specification.....	12
Specification of Touch Detection	13
Control Flow Chart.....	14
Coordinates Data Calculation	20
Register Description	23
Operational Notes.....	28
Ordering Information.....	30
Marking Diagrams.....	30
Physical Dimension, Tape and Reel Information.....	31
Revision History.....	32

Pin Configuration(s)

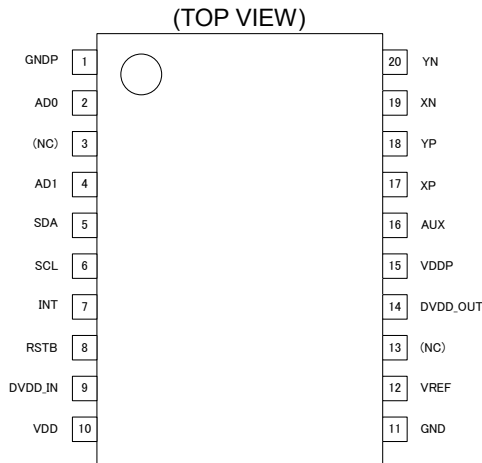

Pin Description(s)

Pin No	Pin Name	I/O	Description	Equivalent circuit
1	GNDP	-	Ground for touch screen drivers	-
2	AD0	I	Slave address input bit0	A
3	(NC)	-	- (Note4)	-
4	AD1	I	Test input (Note1)	A
5	SDA	I/O	Serial data (Note2)	C
6	SCL	I	Serial clock (Note2)	C
7	INT	O	Interrupt output. Pin polarity with active low.	B
8	RSTB	I	System reset	A
9	DVDD_IN	-	Regulator input for control logic. (Note3)	-
10	VDD	-	Power supply	-
11	GND	-	Ground	-
12	VREF	-	Regulator input for control logic. (Note3)	-
13	(NC)	-	- (Note4)	-
14	DVDD_OUT	-	Regulator output for control logic. (Note3)	-
15	VDDP	-	Power supply for touch screen drivers.	-
16	AUX	I	Auxiliary channel input	D
17	XP	I/O	XP channel input	D
18	YP	I/O	YP channel input	D
19	XN	I/O	XN channel input	D
20	YN	I/O	YN channel input	D

(Note1) Connect AD1 to GND.

(Note2) SCL and SDA need a pull-up resistor greater than 2.2kΩ.

(Note3) Bypass VREF, DVDD_IN, DVDD_OUT to GND with a 1.0uF capacitor and do not connect to the supply.

(Note4) Non-connect internal. Please connect to GND or OPEN.

Equivalent Circuit

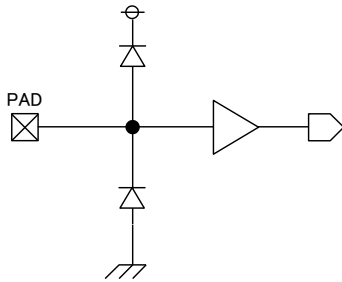

Figure A.

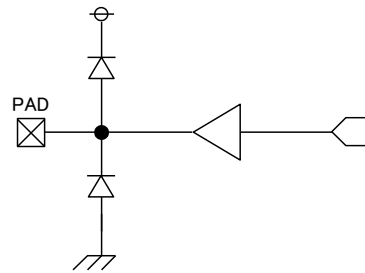

Figure B.

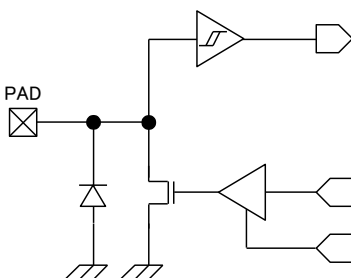

Figure C.

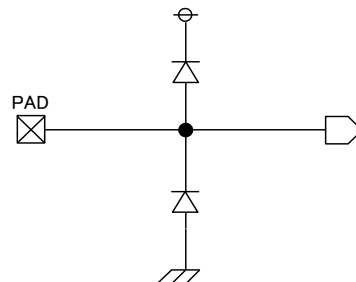
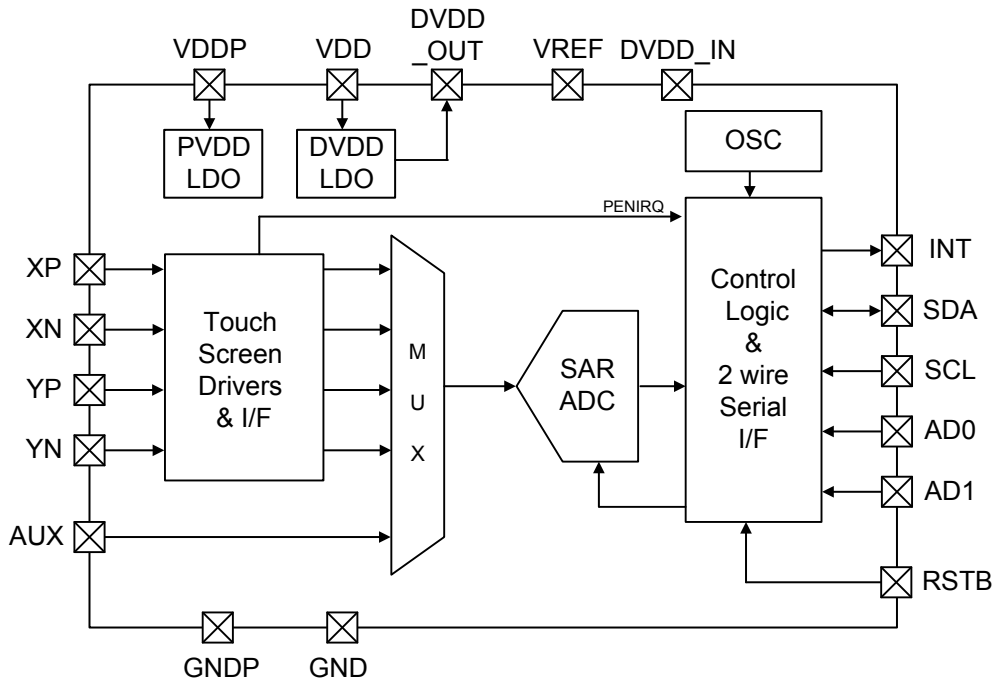

Figure D.

Block Diagram(s)



OVERVIEW

BU21028FV-M is a controller for 4-wire resistive touch screens. It has built-in 12-bit SAR A/D converter, clock oscillator, and LDO regulator for internal blocks and operates with 2.7 to 3.6V single power supply. Aside from being able to detect single point coordinates and touch pressure like existing 4-wire resistive touch screen controllers can, it can also detect dual coordinates by generating data based on the prearranged touch screen parameters.

- Host interface

Communication between BU21028FV-M controller and the host processor uses 2-wire serial interface. The BU21028FV-M, being the I2C slave device, is controlled by the host processor by writing to its registers. This way, the host processor sets whether the touch screen controller operates under command control mode or under automatic control mode. In automatic control mode, the host processor reads the touch data saved by the controller in its internal registers at any time.

- Preprocess

A/D conversion is continuously done for several times in one driving time. Data is median average processed; meaning data is sorted and calculation that takes the average from the center of the sorted data is performed.

- Interrupt control

The BU21028FV-M sends an interrupt signal to the host processor through INT terminal, an active-low pin, whenever it detects touch on the screen. In automatic control mode, this happens after the scan of the first touch is completed.

- 2-point detection function

The 2-point detection function of BU21028FV-M can be used by calibrating the circuit for 2-point detection based on the inherent panel perimeters (registers 0x3, 0x4). Since the characteristics of each touch panel differ significantly, it is necessary for the host processor to execute the calibration of parameters to match the 2-point detection circuit of BU21028FV-M with every touch panel.

- Auto power-down, power-on function(Power control)

After a conversion function has been completed, the BU21028FV-M automatically powers down in order to reduce current consumption. In automatic control mode, scanning restarts automatically from power down when the touch screen is operated.

Absolute Maximum Ratings

Parameter	Symbol	Rating	Unit	Conditions
Power supply voltage	V _{DD}	-0.3 to 4.5	V	
Power supply voltage for touch screen	V _{DDP}	-0.3 to 4.5	V	
Digital input voltage	V _{IN1}	-0.3 to V _{DD} +0.3	V	AD0,AD1,SDA, SCL and RSTB
AUX input voltage	V _{IN2}	GND-0.3 to 2.5	V	AUX
Voltage input to touch screen Interface	V _{IN3}	GND-0.3 to 2.5	V	XP,YP,XN and YN
Storage temperature range	T _{stg}	-50 to 125	°C	

Caution: Operating the IC over the absolute maximum ratings may damage the IC. The damage can either be a short circuit between pins or an open circuit between pins and the internal circuitry. Therefore, it is important to consider circuit protection measures, such as adding a fuse, in case the IC is operated over the absolute maximum ratings.

Thermal Resistance^(Note 1)

Parameter	Symbol	Thermal Resistance (Typ)		Unit
		1s ^(Note 3)	2s2p ^(Note 4)	
SSOP-B20				
Junction to Ambient	θ_{JA}	115.4	57.3	°C/W
Junction to Top Characterization Parameter ^(Note 2)	Ψ_{JT}	10	8	°C/W

(Note 1)Based on JESD51-2A(Still-Air)

(Note 2)The thermal characterization parameter to report the difference between junction temperature and the temperature at the top center of the outside surface of the component package.

(Note 3)Using a PCB board based on JESD51-3.

Layer Number of Measurement Board	Material	Board Size
Single	FR-4	114.3mm x 76.2mm x 1.57mm
Top		
Copper Pattern	Thickness	
Footprints and Traces	70 μ m	

(Note 4)Using a PCB board based on JESD51-7.

Layer Number of Measurement Board	Material	Board Size			
4 Layers	FR-4	114.3mm x 76.2mm x 1.6mm			
Top		2 Internal Layers		Bottom	
Copper Pattern	Thickness	Copper Pattern	Thickness	Copper Pattern	Thickness
Footprints and Traces	70 μ m	74.2mm x 74.2mm	35 μ m	74.2mm x 74.2mm	70 μ m

Recommended Operating Conditions

Parameter	Symbol	Rating			Unit	Conditions
		Min	Typ	Max		
Power supply voltage	VDD	2.7	3.0	3.6	V	
Power supply voltage for touch screen	VDDP	2.7	-	VDD	V	$VDD \geq VDDP$
Operating temperature	Tj	-40	25	85	°C	

Electrical Characteristics (Unless otherwise specified Tj=25°C, VDD=VDDP=3.00V, GND=0.00V)

Parameter	Symbol	Rating			Unit	Conditions
		Min	Typ	Max		
Low-level input voltage	VIL	GND-0.3	-	VDD*0.2	V	AD0,AD1,SDA,SCL and RSTB
High-level input voltage	VIH	VDD*0.8	-	VDD+0.3	V	AD0,AD1,SDA,SCL and RSTB
Low-level output voltage1	VOL1	-	-	GND+0.4	V	SDA(IL=5mA),INT(IL=3mA),
High-level output voltage1	VOH1	VDD-0.4	-	-	V	INT,IL=-3mA
Standby current	Ist	-	-	1.0	uA	RSTB=L
Sleep current	Islp	-	100	200	uA	RSTB=H
Active current	Iact	-	0.8	2.0	mA	No Load
Resolution	Ad	12			Bit	
Differential non-linearity error	DNL	-3	-	+3	LSB	
Integrate non-linearity error	INL	-5	-	+5	LSB	
Switch on-resistance	RON	0.5	5.0	20.0	Ω	XP,XN,YP and YN

Host interface AC timing

The slave address for 2-wire serial interface is selectable from “40h” or “41h” by “AD0” input.

AD0 = “L” : Slave Address = 40h

AD0 = “H” : Slave Address = 41h

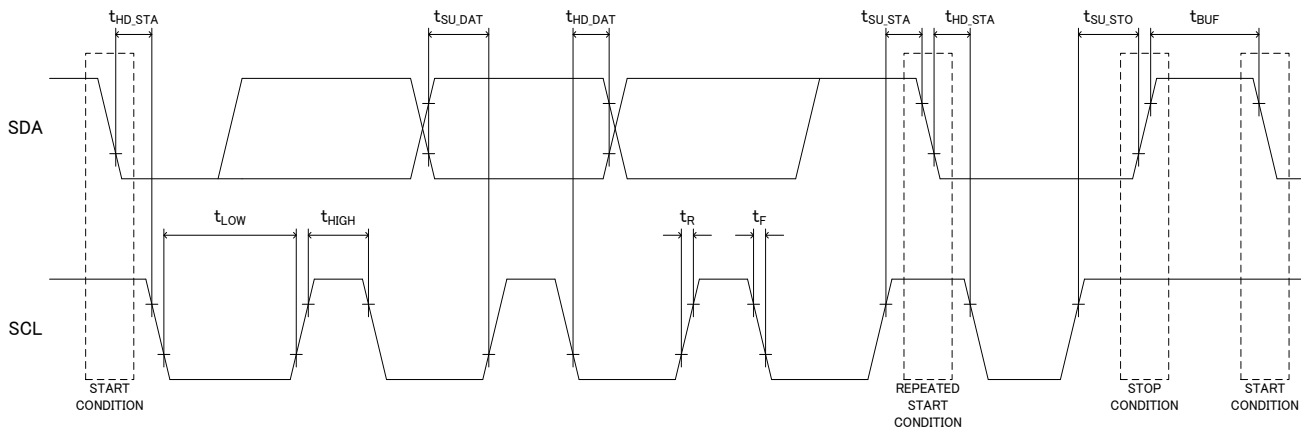

2-wire serial I/F AC timing characteristics ($T_j=25^\circ\text{C}$, $V_{DD}=V_{DDP}=3.00\text{V}$, $GND=0.00\text{V}$, unless otherwise noted)

PARAMETER	SYMBOL	RATING			UNIT	CONDITION
		MIN	TYP	MAX		
SCL clock frequency	f_{SCL}	0	-	400	kHz	
Hold time for (repeated) START condition	$t_{\text{HD_STA}}$	0.6	-	-	us	
Low period of SCL	t_{LOW}	1.3	-	-	us	
High period of SCL	t_{HIGH}	0.6	-	-	us	
Setup time for repeated START condition	$t_{\text{SU_STA}}$	0.6	-	-	us	
Data hold time	$t_{\text{HD_DAT}}$	0	-	0.9	us	
Data setup time	$t_{\text{SU_DAT}}$	0.1	-	-	us	
Rise time for both SCL and SDA	t_{R}	-	-	300	ns	
Fall time for both SCL and SDA	t_{F}	-	-	300	ns	
Setup time for STOP condition	$t_{\text{SU_STO}}$	0.6	-	-	us	
Bus free time between a STOP and START condition	t_{BUF}	1.3	-	-	us	

Host Interface Specification

The BU21028FV-M controller operates as an I2C slave device. At the start of the communication, it receives an address byte transmitted by the host processor and then sends back an acknowledgement byte. The host processor can transmit a command to execute conversion or to access registers only after receiving the acknowledgement for the address byte. Communication ends when BU21028FV-M receives a stop command.

•Address byte

On the address byte, the slave address for 2-wire interface is written on the upper 7 bits and the READ/WRITE bit is written on the last bit. The upper six bits of the slave address are fixed to "100000" while the last bit is determined by the "AD0" input.

Table 1. Serial Interface Slave Address Byte

MSB D7	D6	D5	D4	D3	D2	D1	LSB D0
1	0	0	0	0	0	A0	R/W

Bit D1: A0

Slave address bit0 (AD0)

Bit D0: R/W

1=read (reading data)

0=write (writing data)

•Command byte

The operation of BU21028FV-M is dictated by the command byte. The host processor sets CID (D7) to 1 for conversion function or to 0 for register access.

Table 2. Serial Interface Command Byte 1(CID=1)

MSB D7	D6	D5	D4	D3	D2	D1	LSB D0
1	CF				CMSK	PDM	STP

Bit D7: Command Byte ID

1= Command Byte 1(starts the conversion function determined by CF (Bit D6-D3))

Bits D6-D4: CF

Conversion function is selected as detailed below.

Table 3. BU21028FV-M Conversion Function List

CF	Description
0x0	Touch screen scan function: X, Y, Z1 and Z2 coordinates and converted.
0x1	NOP
0x2	Auxiliary input converted.
0x3	Reserved
0x4	Free scan function: Drivers status and input of A/D assignment by Host.
0x5	Calibration: Parameters which used dual touch detection calibrated.
0x6	NOP
0x7	NOP
0x8	X+, X- drivers status.
0x9	Y+, Y- drivers status.
0xA	Y+, X- drivers status.
0xB	NOP
0xC	Touch screen scan function: X coordinate converted.
0xD	Touch screen scan function: Y coordinate converted.
0xE	Touch screen scan function: Z1 and Z2 coordinates converted.
0xF	Reserved

CF= 0x0 (0000) : Automatic scan

This makes BU21028FV-M periodically and automatically scan the screen and convert data upon detecting touch. When the device cannot detect touch, it stops and stays in power down state until it detects the next pen-down. The order of scan process is Z1, Z2, X and Y.

CF= 0x1 (0001), 0x6 (0110), 0x7 (0111), 0xB (1011)

No operation. ("PDM" and "STP" is valid.)

CF = 0x2 (0010)

This converts the voltage impressed to AUX. After the conversion has been completed, the device is powered down according to the PDM setting.

CF= 0x4 (0100) : Free scan mode

In Free Scan Mode, the driver state (X+, X-, Y+, Y-) and conversion input (X+, X-, Y+, Y-, AUX) can be selected through register settings.

CF= 0x5 (0101) : Calibration

This calibrates the parameters for dual touch detection. To activate the dual touch function, setting of CF to 0101 and execution of the calibration command should be done after power-on.

CF= 0x8 (1000), 0x9 (1001), 0xA (1010): Drivers status control

This activates the analog circuit and panel driver corresponding to each command. BU21028FV-M remains in this state until it receives another SCAN instruction or until "STP" is set.

CF= 0xC (1100), 0xD (1101), 0xE (1110): Manual scan

This converts coordinates that correspond to each command. BU21028FV-M goes to power-down state after a complete conversion if "PDM" is set to "0". Otherwise, it stays at power-on state.

CF =0x3 (0011), 0xF (1111)

Reserved.

Bit D2 : CMSK

0=Executes convert function.

1=Reads the convert result

Bit D1 : PDM

Power Down Control

0= Powers down the device after converter function stops

1= Keeps power on after converter function stops

Bit D0 : STP

1= Aborts currently running conversion and changes the state to power-down (STP is automatically set to "0".)

Table 4. Serial interface Command Byte 0(CID=0)

MSB D7	D6	D5	D4	D3	D2	D1	LSB D0
0	ADDR[3:0]				PAGE	SWRST	STP

Bit D7: Command Byte ID

0=Reads/writes on data register addresses specified by ADDR (Bit D6-D3).

Bits D6-D3: ADDR

D2: PAGE

Register addresses that “ADDR” and “PAGE” can access are listed below.

Table 5. BU21028FV-M Register Map

PAGE	ADDR	INI	7	6	5	4	3	2	1	0
0	0x0	0x20	RSV0	RSV0	CALIB	INTRM	RSV0	RSV0	RSV0	RSV0
	0x1	0xA6	MAV	AVE			-	SMPL		
	0x2	0x04	INTVL_TIME				TIME_ST_ADC			
	0x3	0x10	EVR_X							
	0x4	0x10	EVR_Y							
	0x5	0x10	EVR_XY							
	0x6	0x00	RSV0							
	0x7	0x00	RSV0							
	0x8	0x00	-	-	-	-	RSV0			
	0x9	0x0F	-	-	-	PIMIR_X				
	0xA	0x0F	-	-	-	PIMIR_Y				
	0xB	0x72	RM8	STRETCH	PU90K	DUAL	PIDAC_OFS			
	0xC	0x00	-	RSV1	RSV0	RSV0	-	RSV1	RSV0	RSV0
	0xD	0x00	TEST	AUTO	PDM	-	BUSY	ACTIVE	CALIB DONE	TOUCH
	0xE	0x02	HW_IDH							
0xF	0x29	HW_IDL								
1	0x0	0x00	SW_YP_ POW	SW_YP_ GND	SW_YN_ POW	SW_YN_ GND	SW_XP_ POW	SW_XP_ GND	SW_XN_ POW	SW_XN_ GND
	0x1	0x00	RSV0	RSV0	RSV0	SW_AUX	SW_YPM	SW_YNM	SW_XPM	SW_XNM
	0x2-0x4	-	Reserved							
	0x5	0x03	RSV0	DPRM	RSV0	RSV0	RSV0	RSV0	RSV1	RSV1
	0x6	0x00	RSV0	RSV0	RSV0	RSV0	RSV0	RSV0	RSV0	EX_TIME_ST
	0x7-0xF	-	Reserved							

(*1) RSV0 must be set to 0.

(*2) RSV1 must be set to 1

Bit D1: SWRST

1= Initializes all registers, stops all operations, and changes state to power-down (SWRST is automatically set “0”).

Bit D0: STP

1= Aborts currently running conversion and changes the state to power-down (STP is automatically set to “0”).

•WRITE CYCLE

The host first sends an address byte to the BU21028FV-M controller. This address byte is composed of the 7-bit slave byte on the upper seven bits and the Read/Write bit on the LSB. If the controller receives a valid address byte, it issues an acknowledgement. The host processor can transmit a command only after receiving the acknowledgement for the address byte from the controller. The controller then sends back another acknowledgement, allowing the host to continually send write data or issue a STOP command.

Write : Convert function

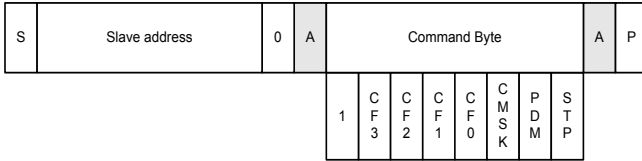

Write : Register write

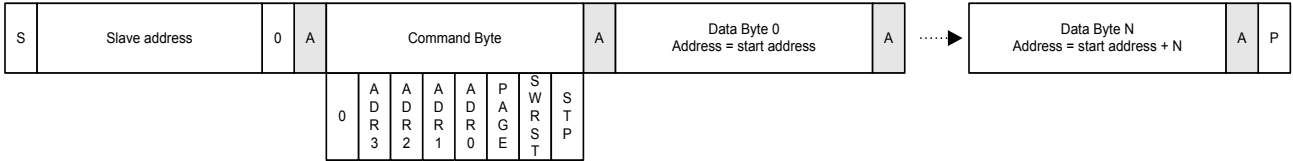

S : START condition P : STOP condition A : ACK N : NACK

Figure 1. Write Protocol

•READ CYCLE

The READ bit is the LSB of the address byte. When read mode is selected, BU21028FV-M sends back the data byte followed by an acknowledgement to the host. The data sent back is either the conversion result or the register value, depending on the last command byte received by BU21028FV-M. The host needs to resend the conversion command with setting "CMSK=1" if it has read the register value before reading the conversion result. BU21028FV-M sends the next data byte after it has received an acknowledgement from the host for the previous data byte. Upon receiving the last data byte, the host finishes read access by issuing a START (or STOP) commands followed by NACK (not acknowledged) command.

Read cycle

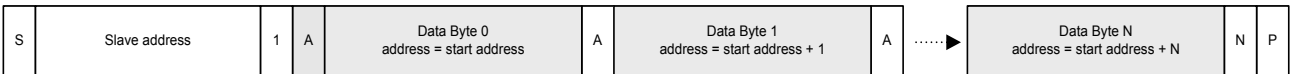

S : START condition P : STOP condition A : ACK N : NACK

Figure 2. Read Protocol

•SCL STRETCH

If the host reads the conversion result while conversion is ongoing, BU21028FV-M notifies it through the SCL_STRETCH function. (*1) SCL_STRECH is released when conversion function is finished.

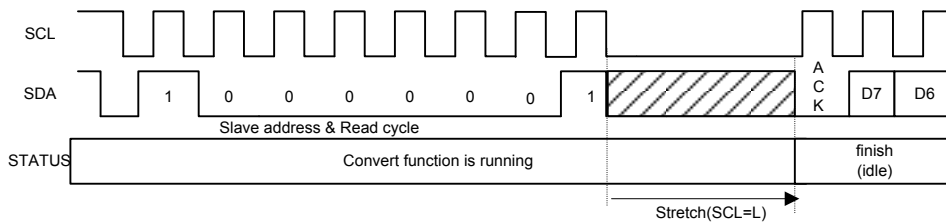

Figure 3. SCL Stretch Timing

Power Supply and Reset Timing Specification

A power supply sequence and timing AC characters of BU21028FV-M are below.
 BU21028FV-M becomes the reset state at RSTB terminal "L" input and the idle state at RSTB terminal "H" input.

In BU21028FV-M, the communication with the host processor becomes active after internal reset release.
 After RSTB= "H" input, please start control of BU21028FV-M after (min: 1.0ms) in waiting time of the internal reset release.

When RSTB terminal becomes the L input, and BU21028FV-M becomes the reset state,
 the data of all registers and the touch data become initial value.
 After having had a reset state, the initialization of the register and power-on sequence is necessary again.

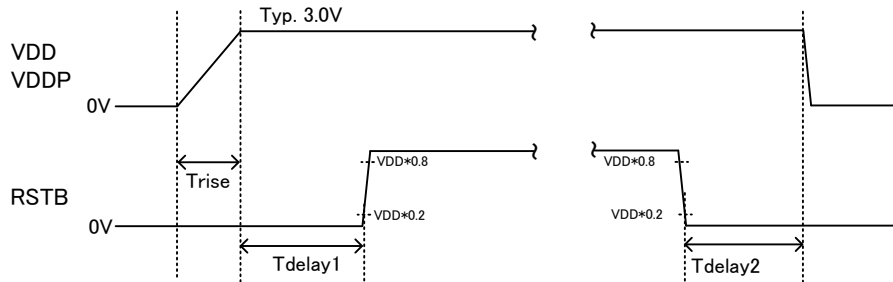

Power-on-reset AC Timing Characteristics (Tj=25°C, VDD=VDDP=3.00V, GND=0.00V, unless otherwise noted)

Parameter	Symbol	Rating			Unit	Condition
		MIN	TYP	MAX		
VDD rise time	Trise	1	-	10	ms	
RSTB rise delay time	Tdelay1	1	-	-	ms	
RSTB fall delay time	Tdelay2	0	-	-	ms	

Specification of Touch Detection

BU21028FV-M executes its touch detection function by outputting an interrupt signal at pin INT once it is able to detect touch. The circuit diagram of the touch detection function is shown on the following figure.

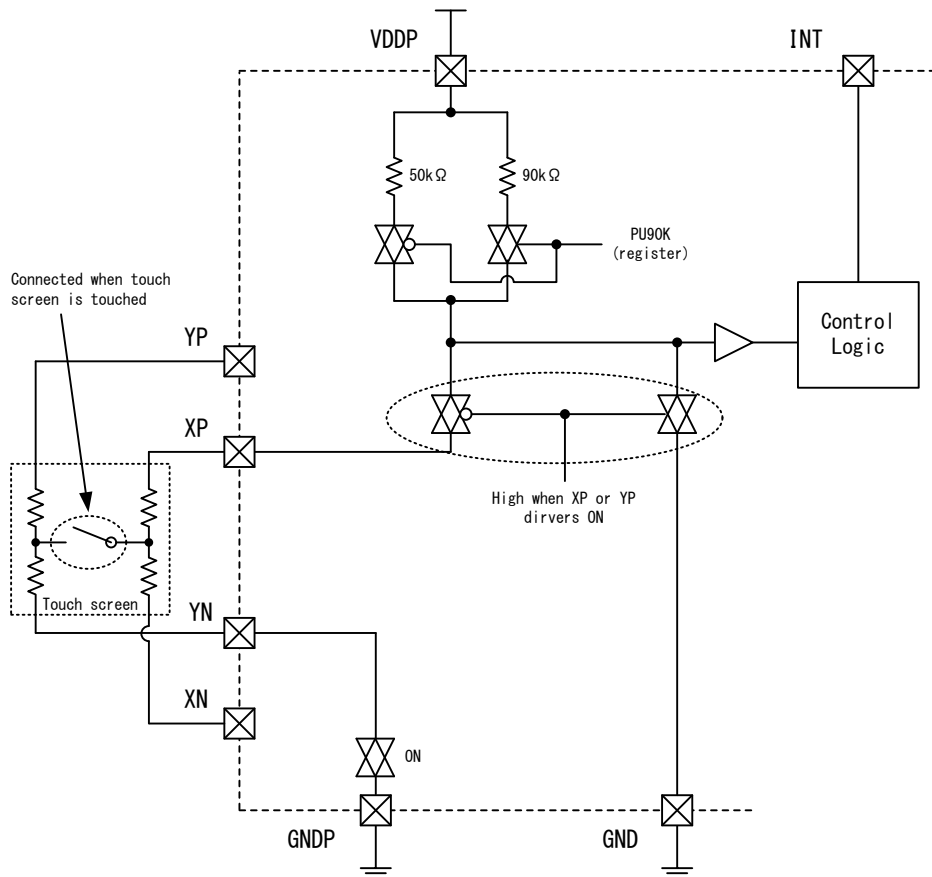

Figure 4. Touch detection circuit

When the touch panel is connected to the panel interface terminals (XP, XN, YP, YN), pin XP is connected to VDDP through an internal pull-up resistor inside the IC and pin YN is connected to GNDP. During a no-touch state, BU21028FV-M will be on standby. During this time, INT outputs "H" through an internal pull-up resistor. Since pins XP and YN are connected to the touch screen through contact resistance, the resistance ratio of the internal pull-up resistance and the touch screen resistance is able to detect the voltage drop at pin XP whenever the screen is touched. This results to an "L" output at INT. When touch is detected and pins XP and YP is put to drive state by each scanning operation, the internal pull-up resistance is disconnected from pin XP and the output of pin INT is held at "L".

Control Flow Chart

BU21028FV-M has two operation modes, the command mode, wherein the device operates under the control of the host processor, and auto mode, wherein the device operates by automatic control. In order to use two-point detection, it is necessary to calibrate the circuit for this function by setting the correct state of registers for panel perimeters (register Addr.0x3, 0x4). Calibration is performed by transmitting the command CF=0101 from the host processor. Take note that each register should be initialized after power on. Moreover, for two-point detection, the interrupt signal from the IC should be enabled after performing parameter calibration.

Power-on Sequence flow chart

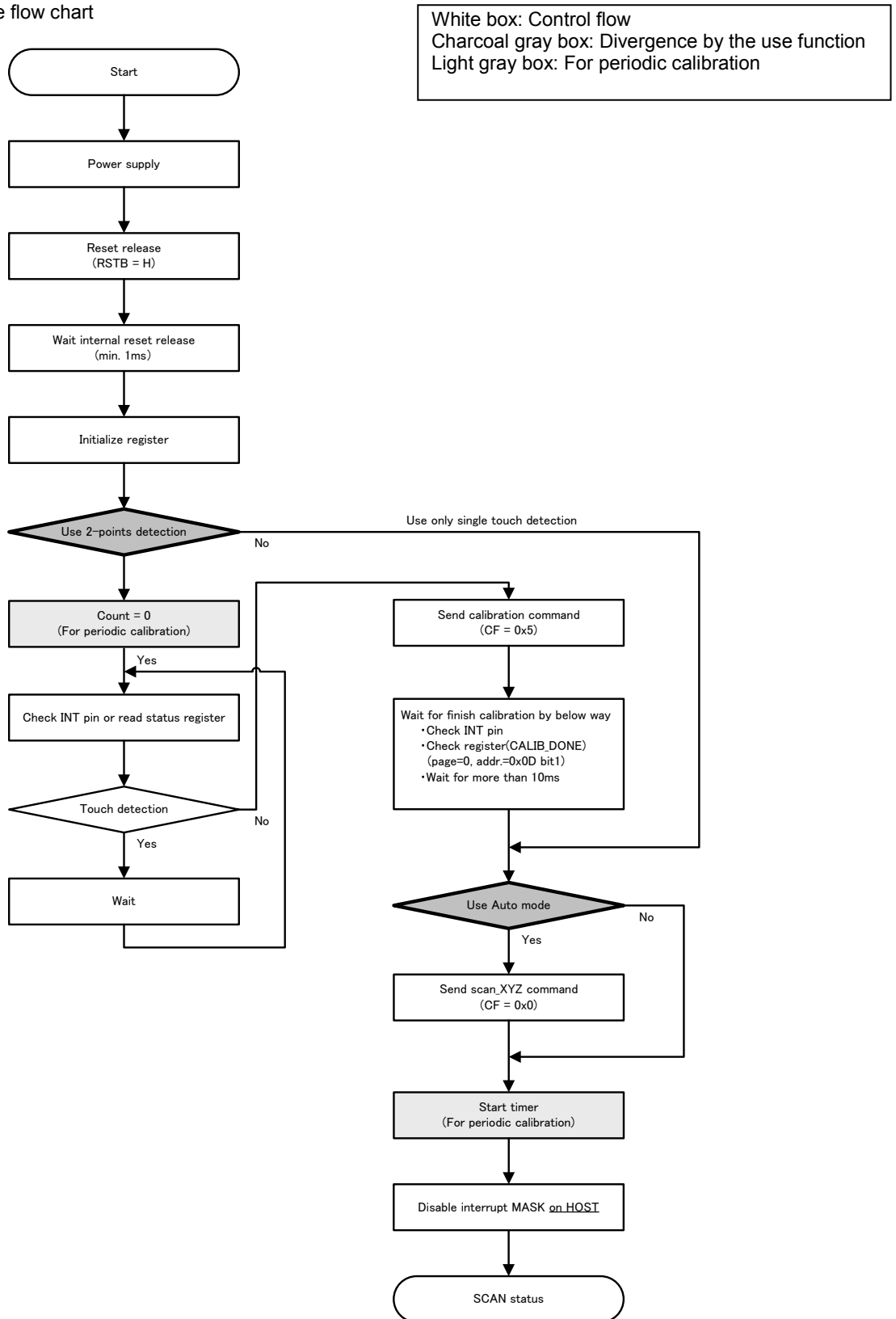

Command Mode

In Command Mode, BU21028FV-M operates totally under the control of the host processor. In order to take touch data, the host processor needs to control BU21028FV-M when there is touch pressure. Since it is necessary for the host processor to issue a command in order to get data, the processing of a host interface in between the presence of touch pressure becomes more active compared with the auto system.

Sensing sequence (Command mode) flow chart

White box: Control flow
 Charcoal gray box: Divergence by the use function
 Light gray box: For periodic calibration

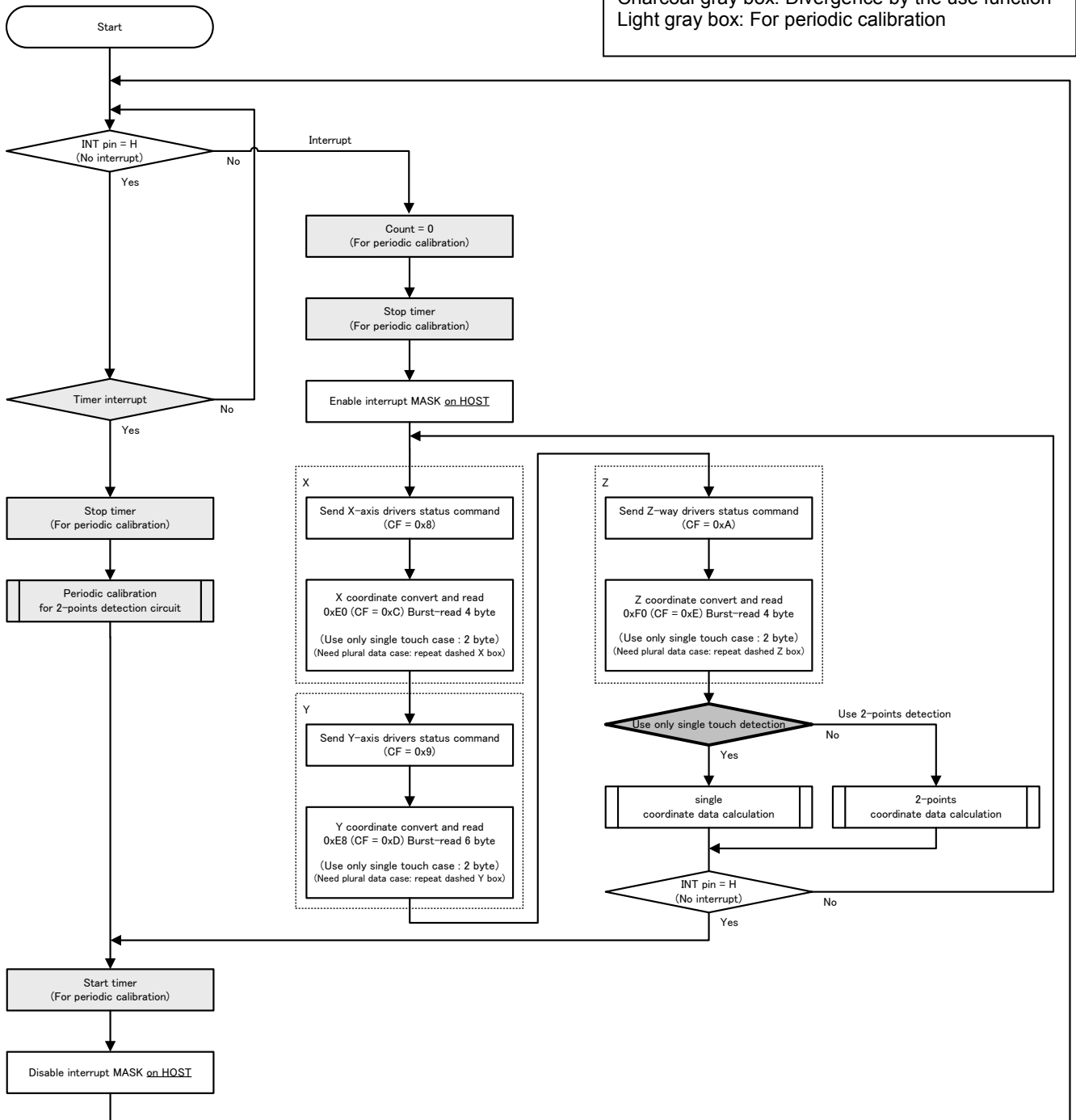

CF=0x5 (0101) Calibration timing chart

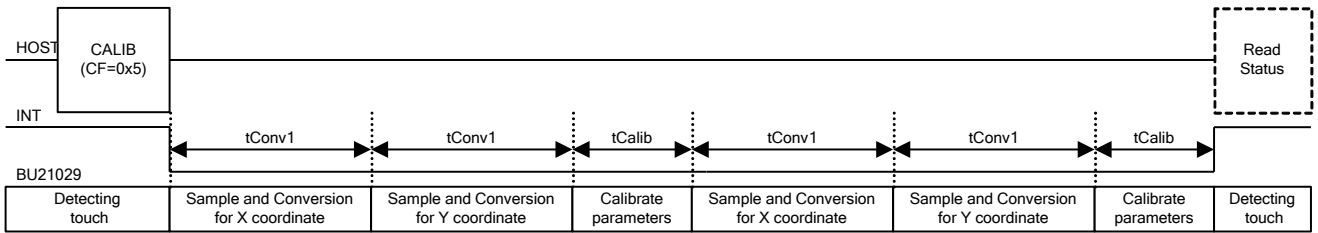

Figure 5. Calibration Flow

$t_{PON} = 710\mu s$
 $t_{DLY1} = 1.5\mu s$
 $t_{ADC} = 18\mu s$
 $t_{DLY2} = 1.0\mu s$
 $t_{TIME_ST_ADC} = \text{register (addr.0x2)}$
 $t_{SMPL} = \text{register (addr.0x1)}$
 $t_{Conv1} = t_{PON} + t_{DLY1} + (t_{TIME_ST_ADC} + (t_{ADC} * t_{SMPL}) * 2 + t_{DLY2})$
 $t_{Calib} = 1 \text{ internal clock}$

(*1) Even if the part with dashed lines is not performed, read status does not influence the operation.
 (*2) Except the first one, $t_{PON}(s)$ is always zero.

Sensing timing chart (command mode)

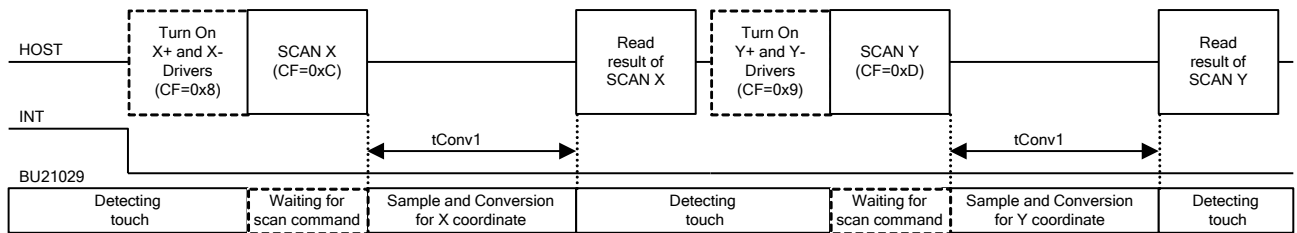

Figure 6. Touch Screen Scan Flow 1 (X and Y scan)

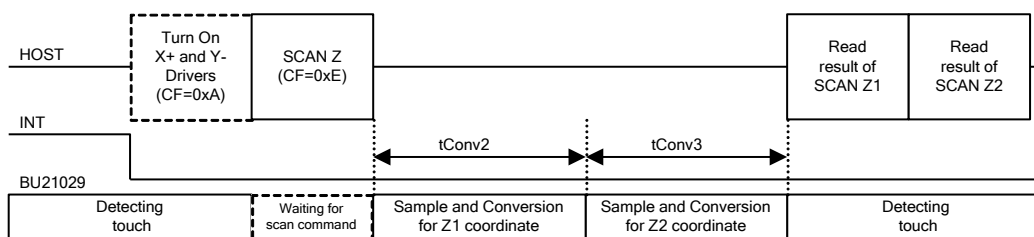

Figure 7. Touch screen scan flow 2 (Z1 and Z2 scan)

$t_{PON} = 710\mu s$
 $t_{DLY1} = 1.5\mu s$
 $t_{ADC} = 18\mu s$
 $t_{DLY2} = 1.0\mu s$
 $t_{TIME_ST_ADC} = \text{register (addr.0x2)}$
 $t_{SMPL} = \text{register (addr.0x1)}$
 $t_{Conv1} = t_{PON} + t_{DLY1} + (t_{TIME_ST_ADC} + (t_{ADC} * t_{SMPL}) * 2 + t_{DLY2})$
 $t_{Conv2} = t_{PON} + t_{DLY1} + t_{TIME_ST_ADC} + (t_{ADC} * t_{SMPL}) + t_{DLY2}$
 $t_{Conv3} = t_{DLY1} + (t_{ADC} * t_{SMPL}) + t_{DLY2}$

(*1) Time is calculated with the oscillating frequency of the internal OSC at 8MHz.
 (*2) In case PDM=1, $t_{PON}(s)$ is set to zero except for the first one.
 (*3) The dashed part is required only when apply time set for a panel is more than $t_{TIME_ST_ADC}$.

Auto Mode

In Auto Mode, BU21028FV-M automatically takes all detected touch and pressure data. An interrupt signal for the 1st data taken is transmitted after detection of touch pressure has been completed. Since BU21028FV-M automatically takes data whenever touch pressure is detected, the host processor does not need to control the touch screen. Auto Mode of operation starts when SCAN-XYZ (CF=0000) is received from the host processor. The INT pin is not concerned with any touch state. It is set to "H" until the 1st touch data from the start of operation is acquired.

Sensing sequence flow chart (Auto mode)

White box: Control flow
 Charcoal gray box: Divergence by the use function
 Light gray box: For periodic calibration

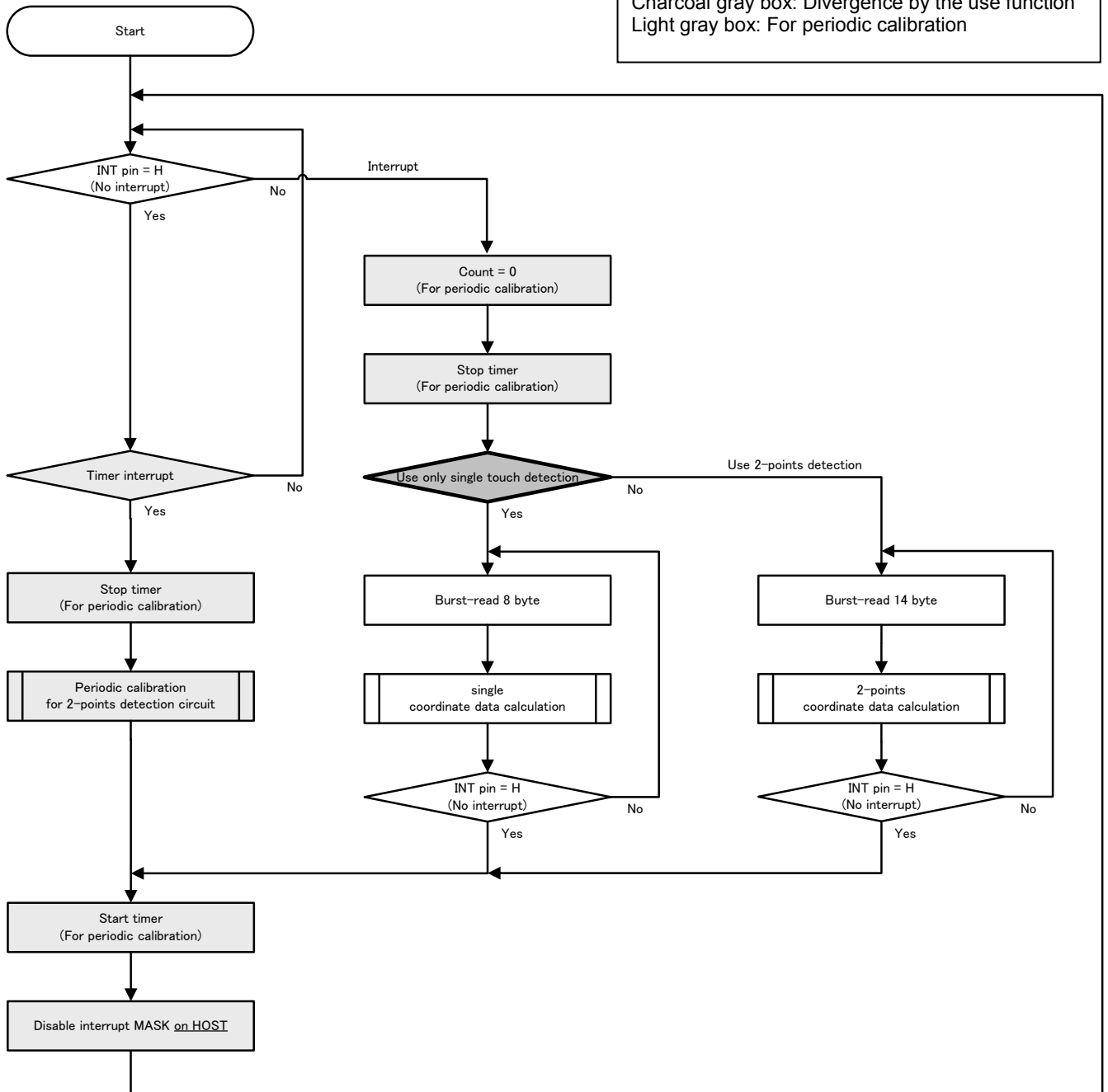

Sensing timing chart (Auto mode)

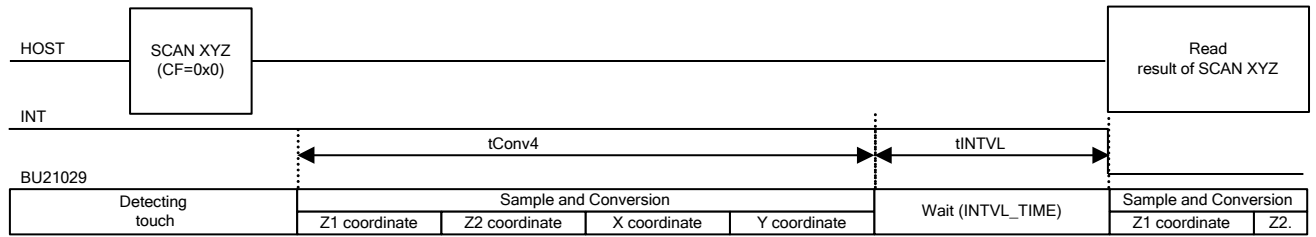

Figure 8. Touch screen scan flow 3 (XYZ scan)

- tPON = 710us
- tDLY1 = 1.5us
- tADC = 18us
- tDLY2 = 1.0us
- tTIME_ST_ADC = register (addr.0x2)
- tINTVL = register (addr.0x2)
- tSMPL = register (addr.0x1)

- tConv4 = tPON + tDLY1 + (tTIME_ST_ADC + (tADC * tSMPL) * 2 + tDLY2) * 3

(*1) Time is calculated with the oscillating frequency of the internal OSC is 8MHz.
 (*2) In the case of PDM=1, every tPON(s) is zero except for the first one.
 (*3) The order of taking each touch data, etc. cannot be changed.

Calibration sequence flow chart

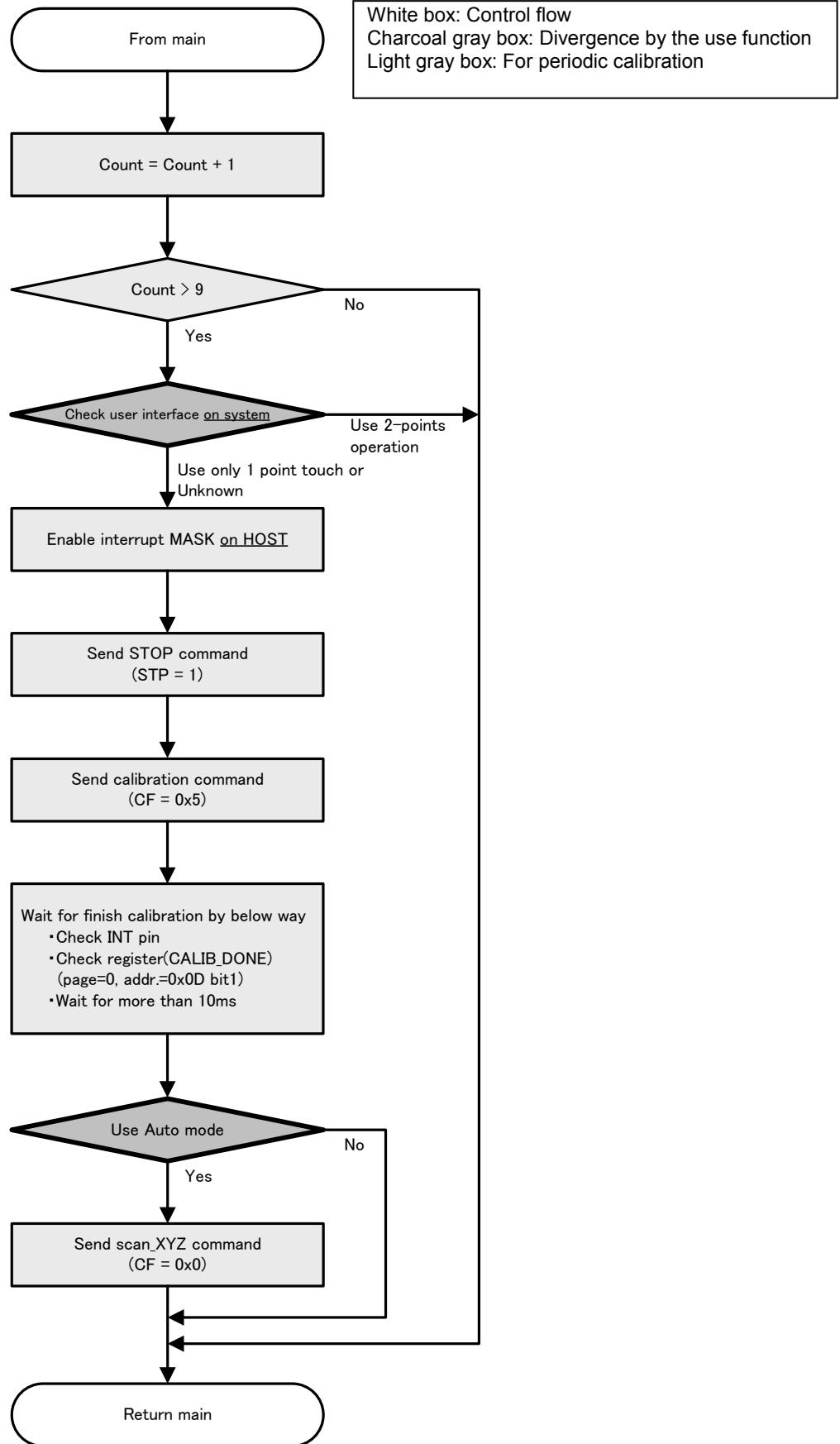

(Note) It is not essential about the “Check user interface”. Please carry it out as needed.

(Note) Please adjust the threshold of Count (“Count > 9” above flowchart) depending on a period of periodic calibration.

Coordinates Data Calculation

The touch position for dual touch is converted to coordinates by the host processor by processing the data which the BU21028FV-M outputs. The data outputted changes with the commands received from the host processor as shown in Table1. The host processor should take data from the BU21028FV-M by burst read via I2C. When reception stops and resumes before all data is taken, data is again outputted from Byte0.

When using only single point detection, it may be the end of reception once each coordinate is taken.

Table 9. The Output Data List of Each Command

0	X	Y	Z1	
1	coordinate	coordinate	coordinate	X coordinate
2	X 2 points paramter	Y 2 points paramter	Z2 coordinate	Y coordinate
4	Dummy	Ghost parameter	Dummy	Z1 coordinate
6	-	-	-	Z2 coordinate
7	-	-	-	
8	-	-	-	
9	-	-	-	X 2 points paramter
10	-	-	-	Y 2 points paramter
11	-	-	-	
12	-	-	-	Ghost parameter
13	-	-	-	
14	-	-	-	Dummy
15	-	-	-	

Table 10. The Output Data Format List

DATA	ByteH								ByteL							
	Bit07	Bit06	Bit05	Bit04	Bit03	Bit02	Bit01	Bit00	Bit07	Bit06	Bit05	Bit04	Bit03	Bit02	Bit01	Bit00
X coordinate	X[11]	X[10]	X[9]	X[8]	X[7]	X[6]	X[5]	X[4]	X[3]	X[2]	X[1]	X[0]	0	0	0	0
Y coordinate	Y[11]	Y[10]	Y[9]	Y[8]	Y[7]	Y[6]	Y[5]	Y[4]	Y[3]	Y[2]	Y[1]	Y[0]	0	0	0	0
Z1 coordinate	Z1[11]	Z1[10]	Z1[9]	Z1[8]	Z1[7]	Z1[6]	Z1[5]	Z1[4]	Z1[3]	Z1[2]	Z1[1]	Z1[0]	0	0	0	0
Z2 coordinate	Z2[11]	Z2[10]	Z2[9]	Z2[8]	Z2[7]	Z2[6]	Z2[5]	Z2[4]	Z2[3]	Z2[2]	Z2[1]	Z2[0]	0	0	0	0
X 2 points parameter	PX[9]	PX[8]	PX[7]	PX[6]	PX[5]	PX[4]	PX[3]	PX[2]	PX[1]	PX[0]	0	0	0	0	0	SPX
Y 2 points parameter	PY[9]	PY[8]	PY[7]	PY[6]	PY[5]	PY[4]	PY[3]	PY[2]	PY[1]	PY[0]	0	0	0	0	0	SPY
Ghost parameter	GH[11]	GH[10]	GH[9]	GH[8]	GH[7]	GH[6]	GH[5]	GH[4]	GH[3]	GH[2]	GH[1]	GH[0]	0	0	0	SGH

(*1)The ByteH is the even number Byte. The ByteL is the odd number Byte. It means that X coordinates are ByteH=Byte0 and ByteL=Byte1 when it is taken with a command method.

X coordinate: Touched coordinate of X. It becomes gravity center coordinate of 2 points at dual touch.

$$X = \text{ByteH} * 16 + \text{ByteL} / 16$$

Y coordinate: Touched coordinate of Y. It becomes gravity center coordinate of 2 points at dual touch.

$$Y = \text{ByteH} * 16 + \text{ByteL} / 16$$

Z1 coordinate: Touched coordinate of Z1. It's used in calculating touch pressure.

$$Z1 = \text{ByteH} * 16 + \text{ByteL} / 16$$

Z2 coordinate: Touched coordinate of Z2. It's used in calculating touch pressure.

$$Z2 = \text{ByteH} * 16 + \text{ByteL} / 16$$

X 2-point touch parameter: It is used for 2-point touch detection. It serves as pointer of the lock up table used for x-axis 2-point distance calculation. PX may be set to 0 when SPX is 1 because the x-axis 2-point distance becomes 0.

$$PX = \text{ByteH} * 4 + \text{ByteL} / 64 \text{ (In the case of SPX=0)}$$

$$PX = 0 \text{ (In the case of SPX=1.)}$$

Y 2-point touch parameter: It is used for 2-point touch detection. It serves as pointer of the lock up table used for y-axis 2-point distance calculation. PY may be set to 0 when SPY is 1 because the y-axis 2-point distance becomes 0.

$$PY = \text{ByteH} * 4 + \text{ByteL} / 64 \text{ (In the case of SPY=0)}$$

$$PY = 0 \text{ (In the case of SPY=1)}$$

Ghost parameter: It is a value for judging a touch position (the direction of inclination) at dual touch.

$$GH = \text{ByteH} * 16 + \text{ByteL} / 16 \text{ (In the case of SGH=0)}$$

$$GH = (\text{ByteH} * 16 + \text{ByteL} / 16) - 4096 \text{ (In the case of SGH=1)}$$

Coordinates data calculation flow chart (Using only 1-point case)

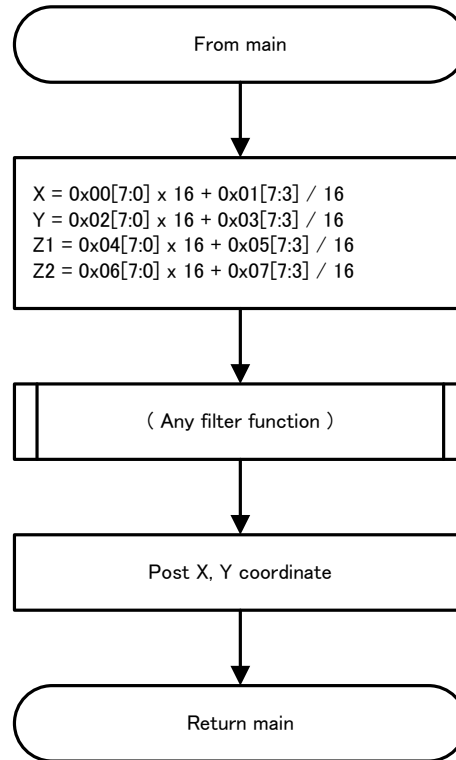

Coordinates data calculation flow chart (Using 2-points case)

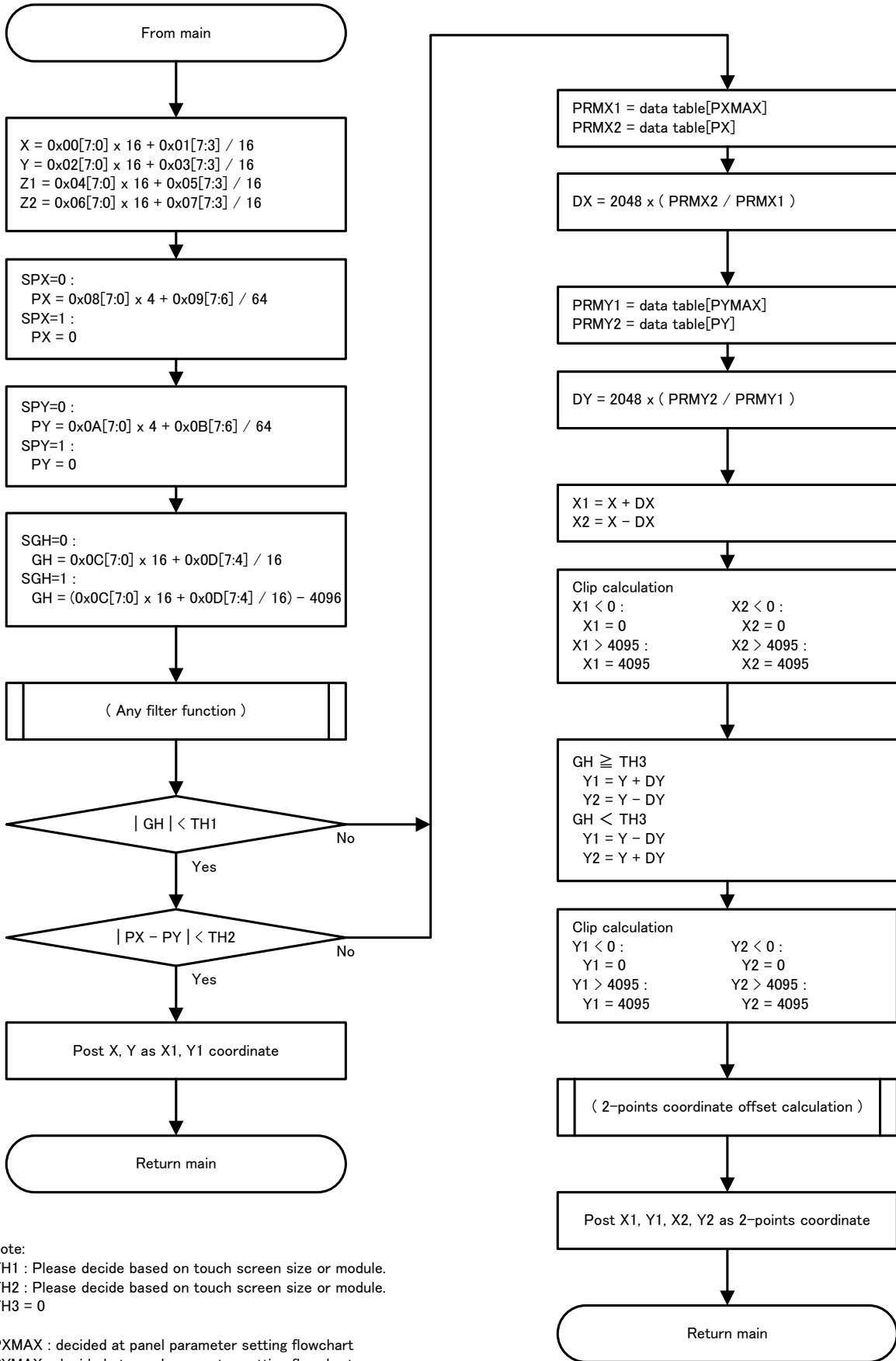

*Note:
 TH1 : Please decide based on touch screen size or module.
 TH2 : Please decide based on touch screen size or module.
 TH3 = 0

PXMAX : decided at panel parameter setting flowchart
 PYMAX : decided at panel parameter setting flowchart

(Note) Please refer application note regarding detail of panel parameter setting flowchart, data table TH1, TH2.

Register Description

Table 12. CFR0 Register (PAGE=0, ADDR=0x0, Reset value=0x20)

D7	D6	D5	D4	D3	D2	D1	D0
RSV0	RSV0	CALIB	INTRM	RSV0	RSV0	RSV0	RSV0

Bits D7-D6, D3-D0: RSV0

Reserved. Set these bits to 0.

Bit D5 : CALIB

Internal parameter setting-1 for calibration of dual touch detection

0= Not to use calibration result

1= Use calibration result

Bit D4 : INTRM

Setting of INT state in case BU21028FV-M is active after conversion by "PDM" setting

0= depend on "pen-down"

1= always output "0"

Table 13. CFR1 Register (PAGE=0, ADDR=0x1, Reset value=0xA6)

D7	D6	D5	D4	D3	D2	D1	D0
MAV	AVE[2:0]			-	SMPL[2:0]		

Bit D7: MAV

Median Average Filter

0= Off

1= On

Bits D6-D4: AVE

AVE+1= The number of average samples setting for MAV. If AVE is greater than SMPL, AVE takes the value of SMPL.

Bits D2-D0: SMPL

SMPL+1= The number of conversion samples setting for MAV.

Ex. In the case of CFR1 = 0xA6 (the number of average samples is 3 and the number of conversion samples is 7)

Conversion result { 1676, 1688, 1656, 1677, 1659, 1702, 4095 }

Sorted result { 1656, 1659, 1676, 1677, 1688, 1702, 4095 }

Chose 3 center data { ~~1656, 2-79~~, 1676, 1677, 1688, ~~1702, 4095~~ }

Average above 3 data = (1676 + 1677 + 1688) / 3 =1680 (vs averaged all six data = 2022)

Table 14. CFR2 Register (PAGE=0, ADDR=0x2, Reset value=0x04)

D7	D6	D5	D4	D3	D2	D1	D0
INTVL_TIME[3:0]				TIME_ST_ADC[3:0]			

Bits D7-D4: INTVL_TIME

This sets the waiting time between completion of conversion and start of next conversion.
(Only usable setting at conversion function=0x0.)

If used, set value as four or more.

Table 15. INTVL_TIME setting

value	time
0x0~0x3	Reserved
0x4	0.256ms
0x5	1.024ms
0x6	2.048ms
0x7	4.096ms
0x8	5.120ms
0x9	8.912ms
0xA	10.240ms
0xB	15.360ms
0xC~0xF	20.480ms

※Times shown above are calculated with oscillating frequency of internal OSC at 8MHz.

Bit D3-D0 : TIME_ST_ADC

This sets the waiting time between application of voltage to panel and start of A/D conversion.

Table 16. TIME_ST_ADC Setting

value	time	
	EX_TIME_ST=0	EX_TIME_ST=1
0x0	10us	0.5ms
0x1	20us	0.6ms
0x2	30us	0.7ms
0x3	40us	0.8ms
0x4	50us	0.9ms
0x5	60us	1.0ms
0x6	70us	1.5ms
0x7	80us	2.5ms
0x8	90us	3.0ms
0x9	100us	4.0ms
0xA	200us	5.0ms
0xB	250us	6.0ms
0xC	300us	7.0ms
0xD	350us	8.0ms
0xE	400us	9.0ms
0xF	450us	10.0ms

※Times shown above are calculated with oscillating frequency of internal OSC at 8MHz.

Table 17. EVR Register (PAGE=0, ADDR=0x3 to 0x5, Reset value=0x10)

D7	D6	D5	D4	D3	D2	D1	D0
EVR_*[7:0]							

Bits D7-D0: EVR_*

This is gain setting 1 for dual touch detection. When using 2-point detection function, it is necessary to set this before conversion. It corresponds to X, Y and XY (Z). It is not necessary to change EVR_XY from initial value.

Table 18. PIMIR Register (PAGE=0, ADDR=0x9 to 0xA, Reset value=0x0F)

D7	D6	D5	D4	D3	D2	D1	D0
-	-	-	PIMIR_*[4:0]				

Bits D4-D0: PIMIR_*

This is gain setting 2 for dual touch detection. It is not necessary to change this from the initial value. It corresponds to X and Y.

Table 19. CFR3 Register (PAGE=0, ADDR=0xB, Reset value=0x72)

D7	D6	D5	D4	D3	D2	D1	D0
RM8	STRETCH	PU90K	DUAL	PIDAC_OFS[3:0]			

Bit D7: RM8

Coordinate resolution setting

0= 12bit

1= 8bit

Bit D6: STRETCH

SCL_STRETCH function setting

0= off

1= on

Bit D5 : PU90K

Internal pull-up resistance for touch detection setting

0= about 50kΩ

1= about 90kΩ

Bit D4: DUAL

Dual touch detection function setting

0= Off

1= On

Bits D3-D0: PIDAC_OFS

Dual touch detection circuit adjustment setting. It is not necessary to change this from initial value.

Table 20. LDO Register (PAGE=0, ADDR=0xC, Reset value=0x00)

D7	D6	D5	D4	D3	D2	D1	D0
-	RSV1	RSV0	RSV0	-	RSV1	RSV0	RSV0

Bit D6 : RSV1

Bit D5-D4 : RSV0

Bit D2 : RSV1

Bit D1-D0 : RSV0

Please set 44h at initialize register in the power on sequence flow chart.

Table 22. STATUS Register (PAGE=0, ADDR=0xD, Reset value=0x00, Read only)

D7	D6	D5	D4	D3	D2	D1	D0
TEST	AUTO	PDM	-	BUSY	ACTIVE	CALIB DONE	TOUCH

Bit D7: TEST

This bit will become "1" during TEST mode.

Bit D6: AUTO

This bit will become "1" at conversion function 0.

Bit D5: PDM

PDM setting value of command byte1

Bit D3: BUSY

This bit will become "1" during conversion of 1st coordinate data.

Bit D2: ACTIVE

This bit will become "1" when internal analog circuit is active.

Bit D1: CALIB_DONE

This bit will become "1" in case that dual touch detection parameter adjustment is finished by command (CF=0x5).

This bit will be clear when "1" is written on this bit.

Bit D0: TOUCH

This bit will become "1" when pen-down is internally detected.

Table 23. HW_ID1 Register (PAGE=0, ADDR=0xE, Reset value=0x02, Read only)

D7	D6	D5	D4	D3	D2	D1	D0
HW_IDH							

Bits D7-D0: HW_IDH

High 8bit of IC's ID

Table 24. HW_ID2 Register (PAGE=0, ADDR=0xF, Reset value=0x29, Read only)

D7	D6	D5	D4	D3	D2	D1	D0
HW_IDL							

Bits D7-D0: HW_IDL

Low 8-bit of IC's ID

Table 25. FREE_SW1 Register (PAGE=1, ADDR=0x0, Reset value=0x00)

D7	D6	D5	D4	D3	D2	D1	D0
SW_YP_ POW	SW_YP_ GND	SW_YN_ POW	SW_YN_ GND	SW_XP_ POW	SW_XP_ GND	SW_XN_ POW	SW_XN_ GND

Bits D7-D0: SW_**_POW(GND)

Driver setting at conversion function 4(Free scan)

Drive to "+" by set POW and "-" by set GND, Must not set "+" and "-" to one terminal at the same time.

** = the corresponding terminal name

Table 26. FREE_SW2 Register (PAGE=1, ADDR=0x1, Reset value=0x00)

D7	D6	D5	D4	D3	D2	D1	D0
RSV0	RSV0	RSV0	SW_AUX	SW_YPM	SW_YNM	SW_XPM	SW_XNM

Bits D7 – D5: RSV0

Reserved. They must be set "0".

Bit D4: SW_AUX

Bit D3-D0: SW_**M

A/D input setting at conversion function 4(Free scan)

** = the corresponding terminal name

Table 27. SPCFG (PAGE=1, ADDR=0x5, Reset value=0x03)

D7	D6	D5	D4	D3	D2	D1	D0
RSV0	DPRM	RSV0	RSV0	RSV0	RSV0	RSV1	RSV1

Bits D7, D5-D2 : RSV0 , Bits D1-D0 : RSV1

RSV0 must be set to 0 and RSV1 must be set to 0

Bit D6: DPRM

2-point touch parameter through mode 0=Off (Normal) 1=On (Through for test).

Operational Notes

1. Reverse Connection of Power Supply

Connecting the power supply in reverse polarity can damage the IC. Take precautions against reverse polarity when connecting the power supply, such as mounting an external diode between the power supply and the IC's power supply pins.

2. Power Supply Lines

Design the PCB layout pattern to provide low impedance supply lines. Furthermore, connect a capacitor to ground at all power supply pins. Consider the effect of temperature and aging on the capacitance value when using electrolytic capacitors.

3. Ground Voltage

Ensure that no pins are at a voltage below that of the ground pin at any time, even during transient condition.

4. Ground Wiring Pattern

When using both small-signal and large-current ground traces, the two ground traces should be routed separately but connected to a single ground at the reference point of the application board to avoid fluctuations in the small-signal ground caused by large currents. Also ensure that the ground traces of external components do not cause variations on the ground voltage. The ground lines must be as short and thick as possible to reduce line impedance.

5. Thermal Consideration

Should by any chance the maximum junction temperature rating be exceeded the rise in temperature of the chip may result in deterioration of the properties of the chip. In case of exceeding this absolute maximum rating, increase the board size and copper area to prevent exceeding the maximum junction temperature rating.

6. Recommended Operating Conditions

These conditions represent a range within which the expected characteristics of the IC can be approximately obtained. The electrical characteristics are guaranteed under the conditions of each parameter.

7. Inrush Current

When power is first supplied to the IC, it is possible that the internal logic may be unstable and inrush current may flow instantaneously due to the internal powering sequence and delays, especially if the IC has more than one power supply. Therefore, give special consideration to power coupling capacitance, power wiring, width of ground wiring, and routing of connections.

8. Operation Under Strong Electromagnetic Field

Operating the IC in the presence of a strong electromagnetic field may cause the IC to malfunction.

9. Testing on Application Boards

When testing the IC on an application board, connecting a capacitor directly to a low-impedance output pin may subject the IC to stress. Always discharge capacitors completely after each process or step. The IC's power supply should always be turned off completely before connecting or removing it from the test setup during the inspection process. To prevent damage from static discharge, ground the IC during assembly and use similar precautions during transport and storage.

Operational Notes – continued**10. Inter-pin Short and Mounting Errors**

Ensure that the direction and position are correct when mounting the IC on the PCB. Incorrect mounting may result in damaging the IC. Avoid nearby pins being shorted to each other especially to ground, power supply and output pin. Inter-pin shorts could be due to many reasons such as metal particles, water droplets (in very humid environment) and unintentional solder bridge deposited in between pins during assembly to name a few.

11. Unused Input Pins

Input pins of an IC are often connected to the gate of a MOS transistor. The gate has extremely high impedance and extremely low capacitance. If left unconnected, the electric field from the outside can easily charge it. The small charge acquired in this way is enough to produce a significant effect on the conduction through the transistor and cause unexpected operation of the IC. So unless otherwise specified, unused input pins should be connected to the power supply or ground line.

12. Regarding the Input Pin of the IC

In the construction of this IC, P-N junctions are inevitably formed creating parasitic diodes or transistors. The operation of these parasitic elements can result in mutual interference among circuits, operational faults, or physical damage. Therefore, conditions which cause these parasitic elements to operate, such as applying a voltage to an input pin lower than the ground voltage should be avoided. Furthermore, do not apply a voltage to the input pins when no power supply voltage is applied to the IC. Even if the power supply voltage is applied, make sure that the input pins have voltages within the values specified in the electrical characteristics of this IC.

13. Ceramic Capacitor

When using a ceramic capacitor, determine the dielectric constant considering the change of capacitance with temperature and the decrease in nominal capacitance due to DC bias and others.

Ordering Information

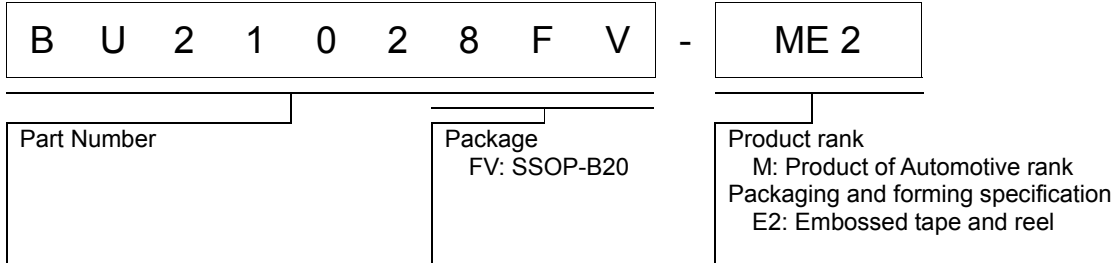

Marking Diagrams

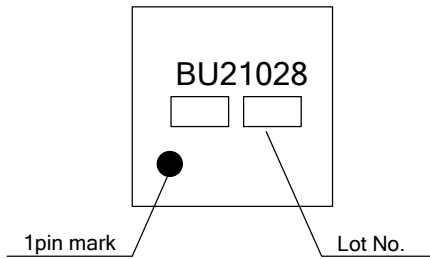

Physical Dimension, Tape and Reel Information

Package Name	SSOP-B20
--------------	----------

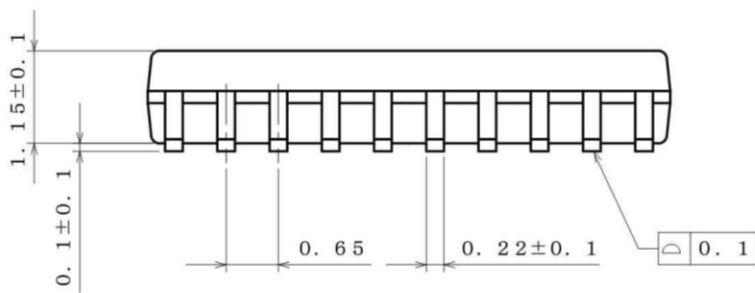
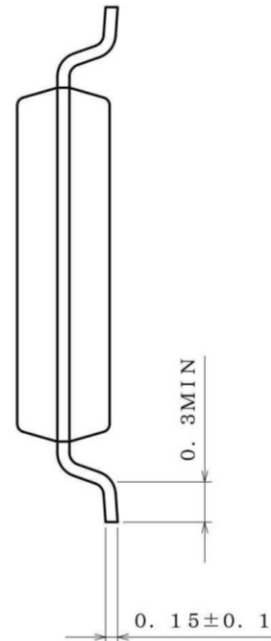
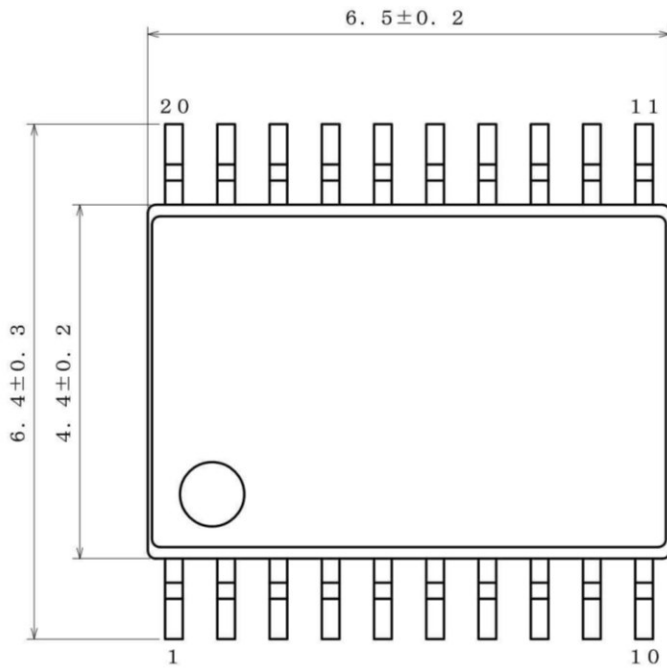

(UNIT : mm)
 PKG : SSOP-B20
 Drawing No. ; EX154-5001

<Tape and Reel information>

Tape	Embossed carrier tape
Quantity	2500pcs
Direction of feed	E2 (The direction is the 1pin of product is at the upper left when you hold reel on the left hand and you pull out the tape on the right hand)

Reel 1pin Direction of feed

*Order quantity needs to be multiple of the minimum quantity.

Revision History

Date	Revision	Changes
13.Jan.2016	001	New Release
27.May.2016	002	<p>Fix miss description.</p> <p>P5. Absolute Maximum Ratings (Ta=25°C) -> Absolute Maximum Ratings</p> <p>P5. Thermal Resistance 2 Internal Layers Copper Pattern : 74.2mm² (Square) -> 74.2mm x 74.2mm Bottom Copper Pattern : 74.2mm² (Square) -> 74.2mm x 74.2mm In table : TO252-J5/TO252-3 -> SSOP-B20</p> <p>P6. (old) Operating temperature Symbol Topr (new) Operating temperature Symbol Tj</p> <p>P6. (old) Unless otherwise specified Ta=25°C, VDD=VDDP=3.00V, GND=0.00V (new) Unless otherwise specified Tj=25°C, VDD=VDDP=3.00V, GND=0.00V</p> <p>P7. (old) Ta=25°C, VDD=VDDP=3.00V, GND=0.00V, unless otherwise noted (new) Tj=25°C, VDD=VDDP=3.00V, GND=0.00V, unless otherwise noted</p> <p>P10.RegisterMap PAGE=0, ADDR=0Ch (old)[6:4]=PVDDLDO_OUT, [2:0]=DVDDLDO_OUT (new)[6:4]=RSV1, [2:0]= RSV1</p> <p>P12. (old) Ta=25°C, VDD=VDDP=3.00V, GND=0.00V, unless otherwise noted (new) Tj=25°C, VDD=VDDP=3.00V, GND=0.00V, unless otherwise noted</p> <p>P25.Register Description PAGE=0, ADDR=0Ch Change to RSV1. Changed comment of setting(below). (old) [6:4]=PVDDLDO_OUT, [2:0]=DVDDLDO_OUT Please set same value to PVDDLDO_OUT and DVDDLDO_OUT. (new) [6]=RSV1, [5:4]=RSV0, [2]= RSV1, [1:0]= RSV0 Please set 44h at initialize register in the power on sequence flow chart.</p>

Notice

Precaution on using ROHM Products

1. If you intend to use our Products in devices requiring extremely high reliability (such as medical equipment ^(Note 1), aircraft/spacecraft, nuclear power controllers, etc.) and whose malfunction or failure may cause loss of human life, bodily injury or serious damage to property ("Specific Applications"), please consult with the ROHM sales representative in advance. Unless otherwise agreed in writing by ROHM in advance, ROHM shall not be in any way responsible or liable for any damages, expenses or losses incurred by you or third parties arising from the use of any ROHM's Products for Specific Applications.

(Note1) Medical Equipment Classification of the Specific Applications

JAPAN	USA	EU	CHINA
CLASS III	CLASS III	CLASS II b	CLASS III
CLASS IV		CLASS III	

2. ROHM designs and manufactures its Products subject to strict quality control system. However, semiconductor products can fail or malfunction at a certain rate. Please be sure to implement, at your own responsibilities, adequate safety measures including but not limited to fail-safe design against the physical injury, damage to any property, which a failure or malfunction of our Products may cause. The following are examples of safety measures:
 - [a] Installation of protection circuits or other protective devices to improve system safety
 - [b] Installation of redundant circuits to reduce the impact of single or multiple circuit failure
3. Our Products are not designed under any special or extraordinary environments or conditions, as exemplified below. Accordingly, ROHM shall not be in any way responsible or liable for any damages, expenses or losses arising from the use of any ROHM's Products under any special or extraordinary environments or conditions. If you intend to use our Products under any special or extraordinary environments or conditions (as exemplified below), your independent verification and confirmation of product performance, reliability, etc. prior to use, must be necessary:
 - [a] Use of our Products in any types of liquid, including water, oils, chemicals, and organic solvents
 - [b] Use of our Products outdoors or in places where the Products are exposed to direct sunlight or dust
 - [c] Use of our Products in places where the Products are exposed to sea wind or corrosive gases, including Cl₂, H₂S, NH₃, SO₂, and NO₂
 - [d] Use of our Products in places where the Products are exposed to static electricity or electromagnetic waves
 - [e] Use of our Products in proximity to heat-producing components, plastic cords, or other flammable items
 - [f] Sealing or coating our Products with resin or other coating materials
 - [g] Use of our Products without cleaning residue of flux (even if you use no-clean type fluxes, cleaning residue of flux is recommended); or Washing our Products by using water or water-soluble cleaning agents for cleaning residue after soldering
 - [h] Use of the Products in places subject to dew condensation
4. The Products are not subject to radiation-proof design.
5. Please verify and confirm characteristics of the final or mounted products in using the Products.
6. In particular, if a transient load (a large amount of load applied in a short period of time, such as pulse. is applied, confirmation of performance characteristics after on-board mounting is strongly recommended. Avoid applying power exceeding normal rated power; exceeding the power rating under steady-state loading condition may negatively affect product performance and reliability.
7. De-rate Power Dissipation depending on ambient temperature. When used in sealed area, confirm that it is the use in the range that does not exceed the maximum junction temperature.
8. Confirm that operation temperature is within the specified range described in the product specification.
9. ROHM shall not be in any way responsible or liable for failure induced under deviant condition from what is defined in this document.

Precaution for Mounting / Circuit board design

1. When a highly active halogenous (chlorine, bromine, etc.) flux is used, the residue of flux may negatively affect product performance and reliability.
2. In principle, the reflow soldering method must be used on a surface-mount products, the flow soldering method must be used on a through hole mount products. If the flow soldering method is preferred on a surface-mount products, please consult with the ROHM representative in advance.

For details, please refer to ROHM Mounting specification

Precautions Regarding Application Examples and External Circuits

1. If change is made to the constant of an external circuit, please allow a sufficient margin considering variations of the characteristics of the Products and external components, including transient characteristics, as well as static characteristics.
2. You agree that application notes, reference designs, and associated data and information contained in this document are presented only as guidance for Products use. Therefore, in case you use such information, you are solely responsible for it and you must exercise your own independent verification and judgment in the use of such information contained in this document. ROHM shall not be in any way responsible or liable for any damages, expenses or losses incurred by you or third parties arising from the use of such information.

Precaution for Electrostatic

This Product is electrostatic sensitive product, which may be damaged due to electrostatic discharge. Please take proper caution in your manufacturing process and storage so that voltage exceeding the Products maximum rating will not be applied to Products. Please take special care under dry condition (e.g. Grounding of human body / equipment / solder iron, isolation from charged objects, setting of Ionizer, friction prevention and temperature / humidity control).

Precaution for Storage / Transportation

1. Product performance and soldered connections may deteriorate if the Products are stored in the places where:
 - [a] the Products are exposed to sea winds or corrosive gases, including Cl₂, H₂S, NH₃, SO₂, and NO₂
 - [b] the temperature or humidity exceeds those recommended by ROHM
 - [c] the Products are exposed to direct sunshine or condensation
 - [d] the Products are exposed to high Electrostatic
2. Even under ROHM recommended storage condition, solderability of products out of recommended storage time period may be degraded. It is strongly recommended to confirm solderability before using Products of which storage time is exceeding the recommended storage time period.
3. Store / transport cartons in the correct direction, which is indicated on a carton with a symbol. Otherwise bent leads may occur due to excessive stress applied when dropping of a carton.
4. Use Products within the specified time after opening a humidity barrier bag. Baking is required before using Products of which storage time is exceeding the recommended storage time period.

Precaution for Product Label

A two-dimensional barcode printed on ROHM Products label is for ROHM's internal use only.

Precaution for Disposition

When disposing Products please dispose them properly using an authorized industry waste company.

Precaution for Foreign Exchange and Foreign Trade act

Since concerned goods might be fallen under listed items of export control prescribed by Foreign exchange and Foreign trade act, please consult with ROHM in case of export.

Precaution Regarding Intellectual Property Rights

1. All information and data including but not limited to application example contained in this document is for reference only. ROHM does not warrant that foregoing information or data will not infringe any intellectual property rights or any other rights of any third party regarding such information or data.
2. ROHM shall not have any obligations where the claims, actions or demands arising from the combination of the Products with other articles such as components, circuits, systems or external equipment (including software).
3. No license, expressly or implied, is granted hereby under any intellectual property rights or other rights of ROHM or any third parties with respect to the Products or the information contained in this document. Provided, however, that ROHM will not assert its intellectual property rights or other rights against you or your customers to the extent necessary to manufacture or sell products containing the Products, subject to the terms and conditions herein.

Other Precaution

1. This document may not be reprinted or reproduced, in whole or in part, without prior written consent of ROHM.
2. The Products may not be disassembled, converted, modified, reproduced or otherwise changed without prior written consent of ROHM.
3. In no event shall you use in any way whatsoever the Products and the related technical information contained in the Products or this document for any military purposes, including but not limited to, the development of mass-destruction weapons.
4. The proper names of companies or products described in this document are trademarks or registered trademarks of ROHM, its affiliated companies or third parties.

General Precaution

1. Before you use our Products, you are requested to carefully read this document and fully understand its contents. ROHM shall not be in any way responsible or liable for failure, malfunction or accident arising from the use of any ROHM's Products against warning, caution or note contained in this document.
2. All information contained in this document is current as of the issuing date and subject to change without any prior notice. Before purchasing or using ROHM's Products, please confirm the latest information with a ROHM sales representative.
3. The information contained in this document is provided on an "as is" basis and ROHM does not warrant that all information contained in this document is accurate and/or error-free. ROHM shall not be in any way responsible or liable for any damages, expenses or losses incurred by you or third parties resulting from inaccuracy or errors of or concerning such information.



BU21028FV-M - Web Page

Part Number	BU21028FV-M
Package	SSOP-B20
Unit Quantity	2500
Minimum Package Quantity	2500
Packing Type	Taping
Constitution Materials List	inquiry
RoHS	Yes