

TaNCap[®] IEEE 1284 Integrated Filter Network

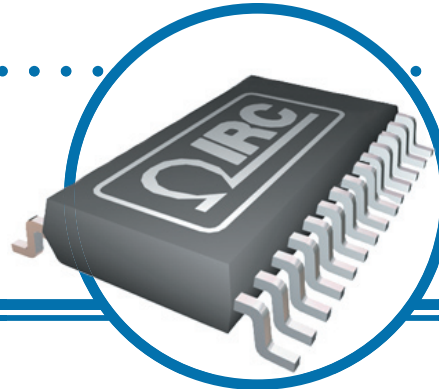

QRC1284x2[™] Series

- Single chip parallel port solution
- Built-in ESD protection into 17 lines
- Proven TaNCap[®] thin film technology
- Highly Integrated - replaces 43 discretes
- RoHS compliant and Sn/Pb terminations available



The IRC TaNCap[®] QRC1284x2 is a single package solution designed for the IEEE1284 enhanced parallel port interface and other digital interface applications. This highly integrated TaNCap[®] thin film technology network offers four different functions in a single 28-pin QSOP package. R1 is a pull-up resistor for, R2 is a series termination resistor and C is a low pass filter capacitor. ESD protection is provided for each termination line.

The 28-pin QSOP package offers a high level of integration in a single surface mount device. 43 discrete passive components are replaced by one IEEE1284x2 filter network.

The TaNCap[®] series of resistor-capacitor networks are manufactured using IRC's military and space proven tantalum nitride thin film technology. For high reliability combined with superior performance, use IEEE1284 filter networks for your most demanding designs.

Electrical Data

	Tolerance (%)	TCR (ppm/°C)	Operating Temperature Range (°C)	Max. Power Dissipation (watts)	Operating Voltage
Resistors	±10	±100	-40 to +85	0.1 per resistor	±6 Volts
Capacitors	±20	N/A	-40 to +85	N/A	

Schematic Data

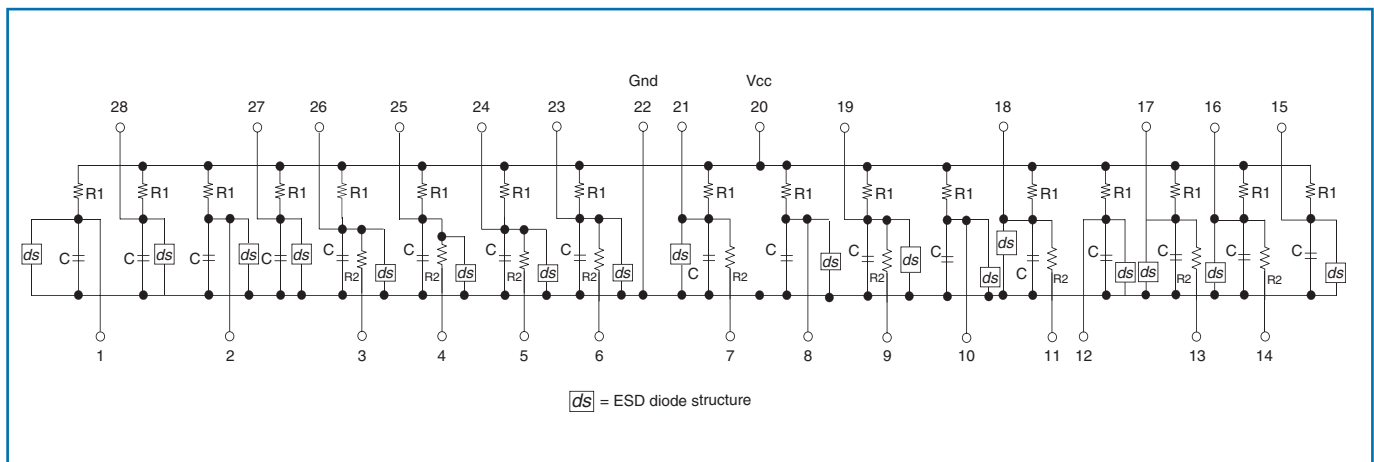

General Note

IRC reserves the right to make changes in product specification without notice or liability. All information is subject to IRC's own data and is considered accurate at time of going to print.



TaNCap[®] IEEE 1284 Integrated Filter Network



Pin-Out Chart

Signal	Source	Termination Resistor R2	Filter Capacitor	Pull-Up Resistor R1	1284x2 Pin	ESD* Protection	1284x2 Pin	ESD* Protection	Circuit Diagram
Data 1	Bi-Directional	X	X	X	25	8KV	4	8KV	1
Data 2	Bi-Directional	X	X	X	24	8KV	5	8KV	1
Data 3	Bi-Directional	X	X	X	23	8KV	6	8KV	1
Data 4	Bi-Directional	X	X	X	21	8KV	7	8KV	1
Data 5	Bi-Directional	X	X	X	19	8KV	9	8KV	1
Data 6	Bi-Directional	X	X	X	18	8KV	11	8KV	1
Data 7	Bi-Directional	X	X	X	17	8KV	13	8KV	1
Data 8	Bi-Directional	X	X	X	16	8KV	14	8KV	1
nAck	Peripheral		X	X	15	8KV			2
Busy	Peripheral		X	X	12	8KV			2
PError	Peripheral		X	X	10	8KV			2
Select	Peripheral		X	X	8	8KV			2
nFault	Peripheral		X	X	27	8KV			2
nInit	Host		X	X	1	8KV			2
nSelectIn	Host		X	X	2	8KV			2
nStrobe	Host	X	X	X	26	8KV	3	8KV	1
nAutoFd	Host		X	X	28	8KV			2

* Human body model per MIL-STD-883 Method 3015.

Circuit Diagrams

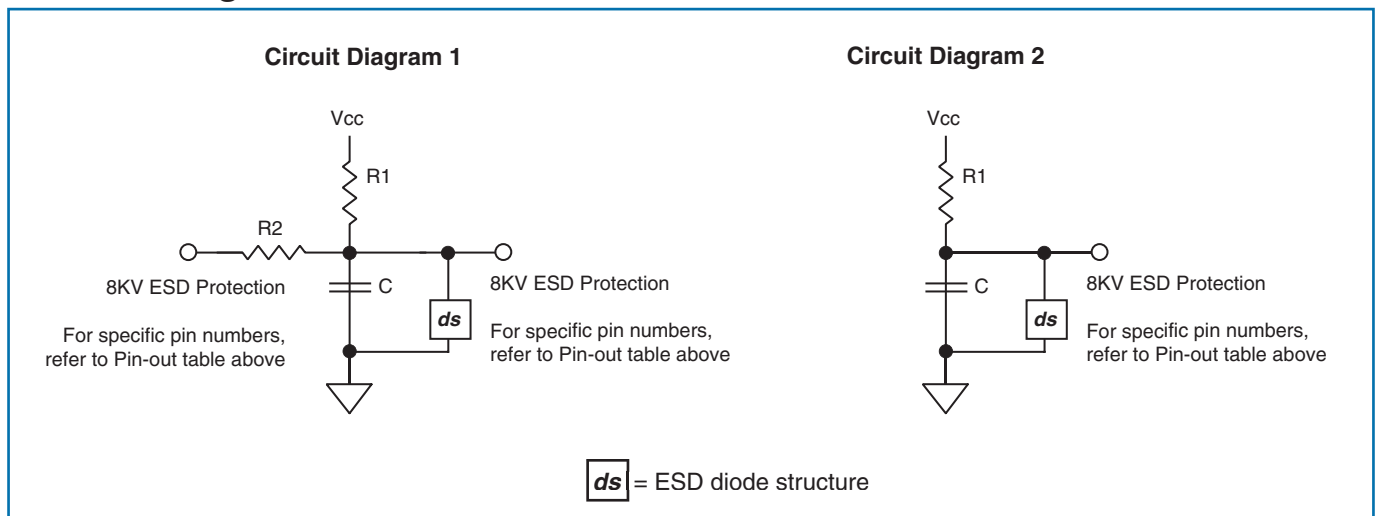

TaNCap[®] IEEE 1284 Integrated Filter Network



Physical Data

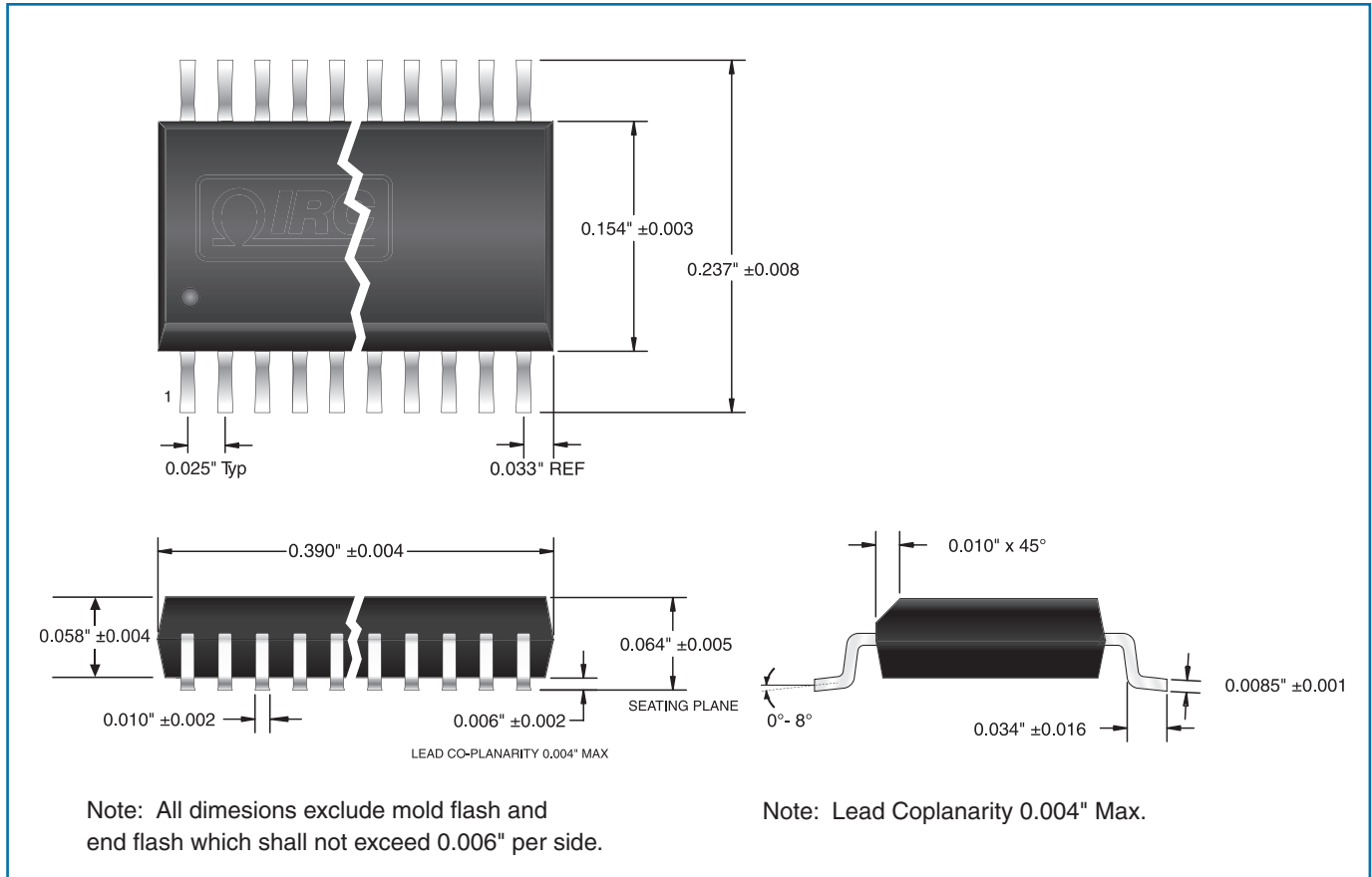

RC Code Table

Code	R1	R2	C
1	2.2KΩ	33Ω	220pF
2	4.7KΩ	33Ω	180pF

Ordering Data

Sample Part No. GUS - QRC1284x2 - 1 - K M

Family

Model
 QRC1284x2 = IEEE1284 Filter with standard Sn/Pb terminations
 QRC1284x2LF = IEEE1284 Filter with 100% matte tin, Pb-free terminations

Resistor-Capacitor Code
 (See RC Code table for available values)

Resistor Tolerance
 K = ±10%

Capacitor Tolerance
 M = ±20%

Packaging Available
 Tubes, Tape & Reel