



HER501 THRU HER508

Ultra Fast Rectifiers

FEATURES

- Plastic package has Underwriters Laboratory Flammability Classification 94V-O utilizing Flame Retardant Epoxy Molding Compound.
- Void-free Plastic in a DO-201AD package.
- 5.0 ampere operation at $T_A=50^{\circ}\text{C}$ With no thermal runaway.
- Ultra Fast switching for high efficiency.
- Exceeds environmental standards of MIL-S-19500/228

MECHANICAL DATA

Case: Molded plastic, DO-201AD

Terminals: Axial leads, solderable per MIL-STD-202, method 208 guaranteed

Polarity: Band denotes cathode

Mounting position: Any

Weight: 0.04ounce, 1.1gram

DO-201AD(DO-27)

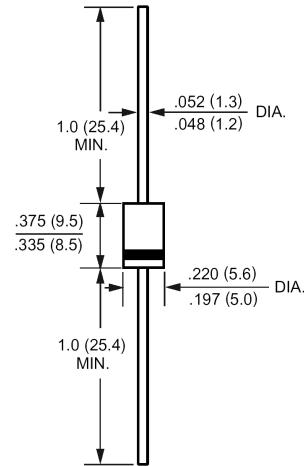

Dimensions in inches and (millimeters)

Maximum Ratings and Electrical Characteristics

Ratings at 25°C ambient temperature unless otherwise specified.

Single phase, half wave, 60Hz, resistive or inductive load.

For capacitive load, derate current by 20%.

	Symbols	HER501	HER502	HER503	HER504	HER505	HER506	HER507	HER508	Units
Maximum Recurrent Peak Reverse Voltage	V_{RRM}	50	100	200	300	400	600	800	1000	Volts
Maximum RMS Voltage	V_{RMS}	35	70	140	210	280	420	560	700	Volts
Maximum DC Blocking Voltage	V_{DC}	50	100	200	300	400	600	800	1000	Volts
Maximum Average Forward Rectified Current .375"(9.5mm) Lead Length at $T_A=50^{\circ}\text{C}$	$I_{(AV)}$	5.0								Amp
Peak Forward Surge Current, 8.3ms single half-sine-wave superimposed on rated load (JEDEC method)	I_{FSM}	150								Amp
Maximum Forward Voltage at 5.0A and $T_A=25^{\circ}\text{C}$	V_F	1.0		1.3		1.7				Volts
Maximum Reverse Current at $T_J=25^{\circ}\text{C}$ at Rated DC Blocking Voltage $T_J=100^{\circ}\text{C}$	I_R	10.0 750								μAmp
Typical Junction Capacitance (Note 1)	C_J	70				50				pF
Maximum Reverse Recovery Time (Note 2)	T_{RR}	50				75				nS
Typical Thermal Resistance (Note 3)	$R_{\theta JA}$	20								$^{\circ}\text{C/W}$
Operating and Storage Temperature Range	T_J, T_{stg}	-55 to +150								$^{\circ}\text{C}$

NOTES:

1- Measured at 1 MHz and applied reverse voltage of 4.0 VDC.

2- Reverse Recovery Test Conditions: $I_F=5\text{A}$, $I_R=1\text{A}$, $I_{RR}=0.25\text{A}$.

3- Thermal Resistance from Junction to Ambient at 0.375"(9.5mm) lead length P.C.B. Mounted.





HER501 THRU HER508

Ultra Fast Rectifiers

RATINGS AND CHARACTERISTIC CURVES

FIG. 1 - TEST CIRCUIT DIAGRAM AND REVERSE RECOVERY TIME CHARACTERISTIC

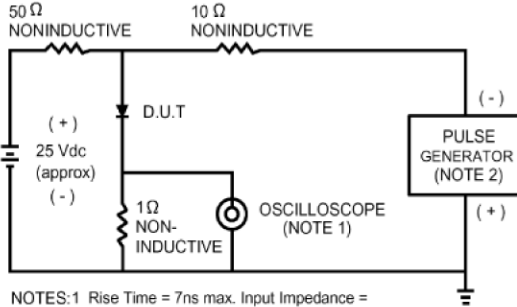

NOTES: 1 Rise Time = 7ns max. Input Impedance = 1 megohm. 22pF.
2. Rise Time = 10ns max. Source Impedance = 50 ohms.

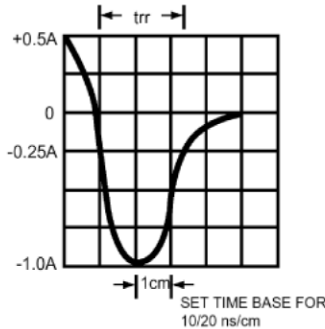

FIG. 2 - TYPICAL FORWARD CURRENT DERATING CURVE

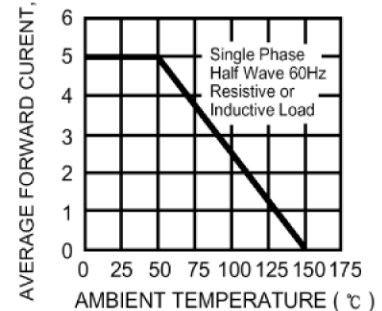

FIG. 3 - TYPICAL REVERSE CHARACTERISTICS

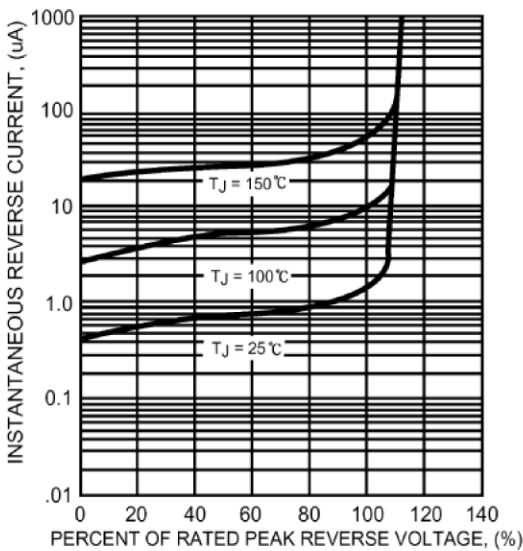

FIG. 4 - TYPICAL INSTANTANEOUS FORWARD CHARACTERISTICS

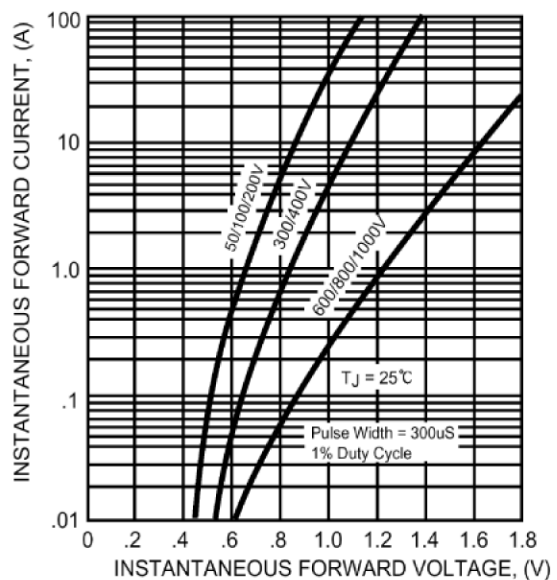

FIG. 5 - TYPICAL INSTANTANEOUS FORWARD CHARACTERISTICS

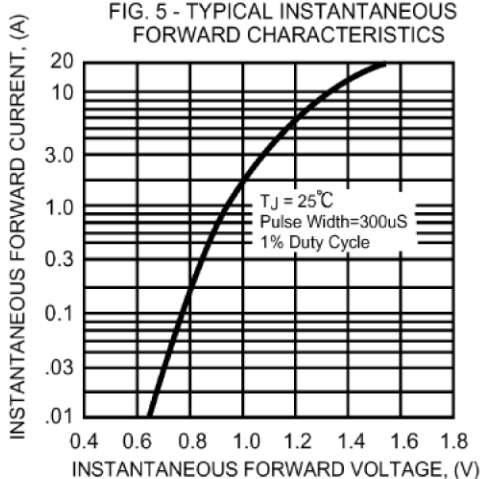

FIG. 6 - TYPICAL JUNCTION CAPACITANCE

