

144S...-PCB Series

Signal conditioned precision pressure transducers

FEATURES

- 70 mbar to 10 bar, 1 to 150 psi, absolute, gage or differential pressure
- Barometric pressure ranges
- 0...5 V output
- Internal supply regulation
- Precision temperature compensated and calibrated

SERVICE

Non-corrosive, non-ionic working fluids, such as dry air and dry gases.

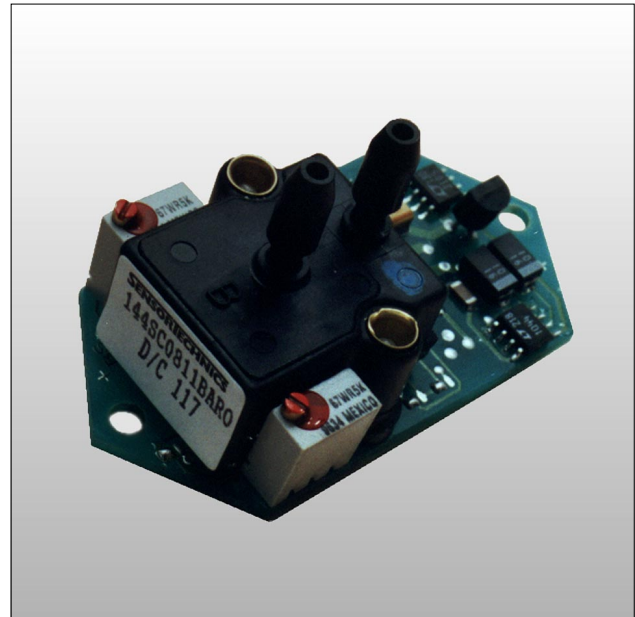

SPECIFICATIONS

Maximum ratings

Supply voltage	7.5...24 V
Maximum load current	
source	20 mA
sink	10 mA
Temperature limits	
Storage	-55 to 100°C
Operating	-40 to 85°C
Compensated	
144SC...BARO	-10 to 60°C
all others	0 to 70 °C
Lead temperature (10 sec soldering)	300°C
Humidity limits	
pressure inlets only	0 - 100 %RH
Proof pressure ¹	
144SM...	1.4 bar
144SB010...	16 bar
144SC...BARO	2 bar
144SU01..., 144SU05...	20 psi
144SU150...	250 psi
all others	2x rated pressure

ELECTRICAL CONNECTION

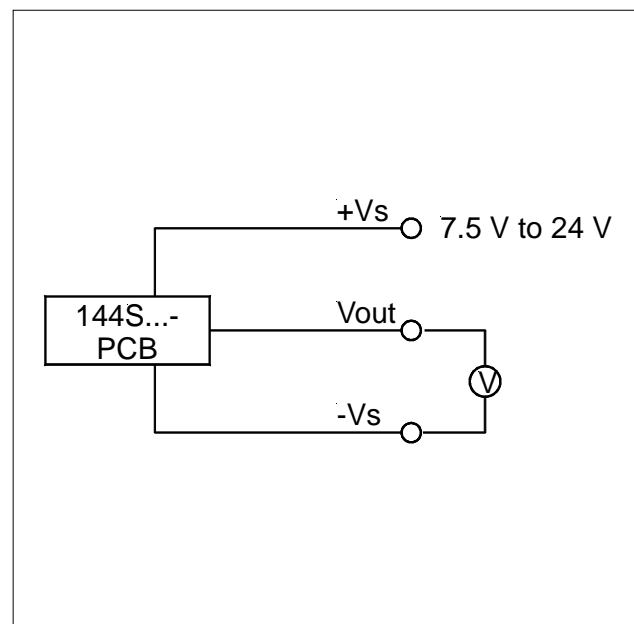

144S...-PCB Series

Signal conditioned precision pressure transducers

PERFORMANCE CHARACTERISTICS

STANDARD DEVICES

(unless otherwise noted $V_s = 8\text{ V}$, $R_L > 100\text{ k}\Omega$, $t_{amb} = 25^\circ\text{C}$)

Characteristics			Min.	Typ.	Max.	Unit
Operating pressure	differential devices ²	144SM070D-PCB	0		70	mbar
		144SM350D-PCB	0		350	
		144SB001D-PCB	0		1	bar
		144SB002D-PCB	0		2	
		144SB005D-PCB	0		5	
		144SB010D-PCB	0		10	
	absolute devices ³	144SB001A-PCB	0		1	
		144SB002A-PCB	0		2	
		144SB005A-PCB	0		5	
	differential devices ²	144SU01D-PCB	0		1	psi
		144SU05D-PCB	0		5	
		144SU15D-PCB	0		15	
		144SU30D-PCB	0		30	
		144SU100D-PCB	0		100	
absolute devices ³		144SU15A-PCB	0		15	
	144SU30A-PCB	0		30		
	144SU100A-PCB	0		100		
Zero pressure offset			-0.05	0	0.05	V
Full scale span ⁴			4.9	5.0	5.1	
Full scale output			4.9	5.0	5.1	
Non-linearity and hysteresis (BSL) ⁵				0.1	0.5	%FSO
Thermal effects (0 to 70°C) ⁶	Offset	144SM070...,144SU01...		0.6	3.0	
		144SM350...,144SU05... all others		0.2 0.15	1.0 0.6	
	Span			0.2	1.0	
Long term stability ⁷				0.1		
Response time (10 to 90 %)				1		ms
Power consumption (no load)				70		mW
Power supply rejection	Offset			0.05		%FSO/V
	Span			0.03		

144S...-PCB Series

Signal conditioned precision pressure transducers

PERFORMANCE CHARACTERISTICS

BAROMETRIC DEVICES⁸

(unless otherwise noted $V_s = 8\text{ V}$, $R_L > 100\text{ k}\Omega$, $t_{amb} = 25^\circ\text{C}$)

Characteristics		Min.	Typ.	Max.	Unit
Operating pressure ranges ³	144SC0811BARO	800		1100	mbar
	144SC1216BARO	12		16	psia
Offset calibration at lowest specified pressure		-0.05	0	0.05	V
Full scale output		4.95	5.0	5.05	
Non-linearity and hysteresis ⁵			0.05	0.1	%FSO
Long term stability ⁷			0.1		
Thermal effects (-10 to 60°C) ⁹			0.05	0.3	%FSO/10°C
Response time (10 to 90 %)			1		ms
Power consumption (no load)			70		mW
Power supply rejection	Offset		0.05		%FSOV
	Span		0.03		

Specification notes:

1. Proof pressure is the maximum pressure which may be applied without causing damage to the sensing element.
2. The output signal of all 144S...D-PCB devices is proportional to the pressure applied to port B, relative to port A, e.g. the output signal increases when vacuum is applied to port A relative to port B.
3. The output signal of all 144S...A-PCB and 144SC...BARO devices is proportional to the pressure applied to port A.
4. Full scale span is the algebraic difference between the positive full scale output and the zero pressure offset.
5. Non-linearity refers to the **Best Straight Line** fit measured for offset pressure, full scale pressure and 1/2 full scale pressure.
6. Thermal effects tested and guaranteed from 0 to 70°C relative to 25°C. All specifications shown are relative to 25°C.
7. Change in output after one year or 1 million pressure cycles.
8. These devices are factory calibrated at sea level. When used at other altitudes the output signal differs from the reading expected when comparing to the pressure given from your local weather station. The weather station always reports the pressure compared to sea level. On that the output signal of the transducer will change 65mV/0.052 psi per 100 feet e.g. 19.7mV/1.18 mbar per 10 m change in altitude. The output signal can be adjusted to sea level reading by turning the offset trimmer.
9. Thermal effects refer to the combined effects of offset and sensitivity shifts, this is true from -10 to 60°C relative to 25°C.

144S...-PCB Series

Signal conditioned precision pressure transducers

OUTLINE DRAWING

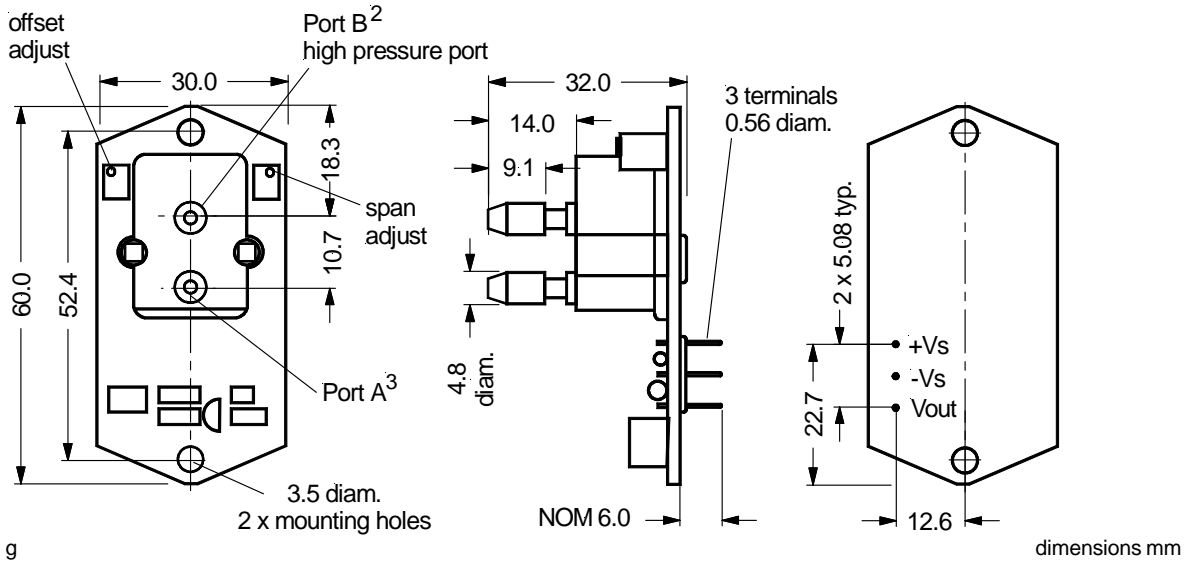

ORDERING INFORMATION

Operating Pressure	Part Number	
Differential/gage devices	0...70 mbar	144SM070D-PCB
	0...350 mbar	144SM350D-PCB
	0...1 bar	144SB001D-PCB
	0...2 bar	144SB002D-PCB
	0...5 bar	144SB005D-PCB
	0...10 bar	144SB010D-PCB
Absolute devices	0...1 bar	144SB001A-PCB
	0...2 bar	144SB002A-PCB
	0...5 bar	144SB005A-PCB
Differential/gage devices	0...1 psi	144SU01D-PCB
	0...5 psi	144SU05D-PCB
	0...15 psi	144SU15D-PCB
	0...30 psi	144SU30D-PCB
	0...100 psi	144SU100D-PCB
	0...150 psi	144SU150D-PCB
Absolute devices	0...15 psi	144SU15A-PCB
	0...30 psi	144SU30A-PCB
	0...100 psi	144SU100A-PCB
Barometric devices	12...16 psia	144SC1216BARO
	800...1100 mbar	144SC0811BARO

Other pressure ranges and calibrations are available on request. Please contact First Sensor.

First Sensor reserves the right to make changes to any products herein. First Sensor does not assume any liability arising out of the application or use of any product or circuit described herein, neither does it convey any license under its patent rights nor the rights of others.