

### General Description

The ICS85314I-11 is a low skew, high performance 1-to-5 Differential-to-2.5V, 3.3V LVPECL fanout buffer. The ICS85314I-11 has two selectable differential clock inputs. The CLK0, nCLK0 and CLK1, nCLK1 pairs can accept most standard differential input levels. The clock enable is internally synchronized to eliminate runt clock pulses on the outputs during asynchronous assertion/deassertion of the clock enable pin.

Guaranteed output and part-to-part skew characteristics make the ICS85314I-11 ideal for those applications demanding well defined performance and repeatability.

### Features

- Five differential 2.5V/3.3V LVPECL outputs
- Selectable differential CLKx, nCLKx inputs
- CLK0, nCLK0 and CLK1, nCLK1 pairs can accept the following differential input levels: LVPECL, LVDS, LVHSTL, HCSL, SSTL
- Maximum output frequency: 700MHz
- Translates any single-ended input signal to 3.3V LVPECL levels with resistor bias on nCLK input
- Output skew: 30ps (maximum)
- Propagation delay: 1.8ns (maximum)
- LVPECL mode operating voltage supply range: V<sub>CC</sub> = 2.375V to 3.8V, V<sub>EE</sub> = 0V
- -40°C to 85°C ambient operating temperature
- Lead-free (RoHS 6) packaging

### Block Diagram

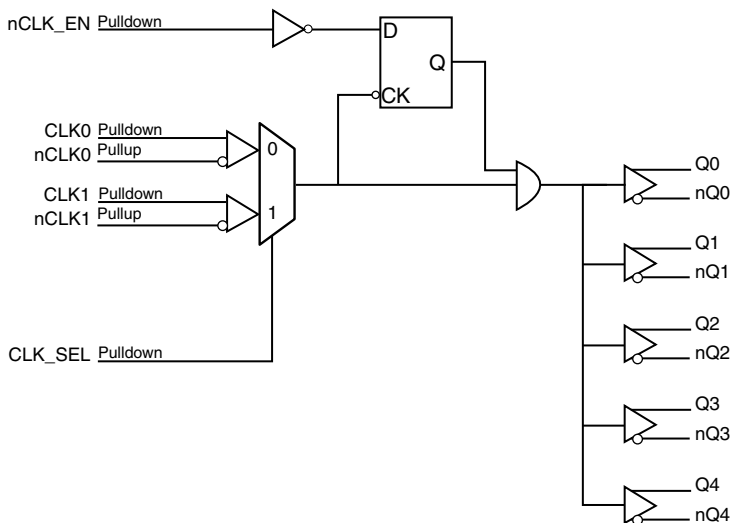

### Pin Assignment

Q0	1	20	Vcc
nQ0	2	19	nCLK_EN
Q1	3	18	Vcc
nQ1	4	17	nCLK1
Q2	5	16	CLK1
nQ2	6	15	RESERVED
Q3	7	14	nCLK0
nQ3	8	13	CLK0
Q4	9	12	CLK_SEL
nQ4	10	11	VEE

#### ICS85314I-11

#### 20-Lead TSSOP

6.5mm x 4.4mm x 0.92mm package body

G Package

Top View

#### ICS85314I-11

#### 20-Lead SOIC

7.5mm x 12.8mm x 2.3mm package body

M Package

Top View

**Table 1. Pin Descriptions**

Number	Name	Type		Description
1, 2	Q0, nQ0	Output		Differential output pair. LVPECL interface levels.
3, 4	Q1, nQ1	Output		Differential output pair. LVPECL interface levels.
5, 6	Q2, nQ2	Output		Differential output pair. LVPECL interface levels.
7, 8	Q3, nQ3	Output		Differential output pair. LVPECL interface levels.
9, 10	Q4, nQ4	Output		Differential output pair. LVPECL interface levels.
11	V <sub>EE</sub>	Power		Negative supply pin.
12	CLK_SEL	Input	Pulldown	Clock select input. When HIGH, selects CLK1, nCLK1 inputs. When LOW, selects CLK0, nCLK0 inputs. LVTTTL / LVCMOS interface levels.
13	CLK0	Input	Pulldown	Non-inverting differential clock input.
14	nCLK0	Input	Pullup	Inverting differential clock input.
15	RESERVED	Reserve		Reserved pin.
16	CLK1	Input	Pulldown	Non-inverting differential clock input.
17	nCLK1	Input	Pullup	Inverting differential clock input.
18, 20	V <sub>CC</sub>	Power		Positive supply pins.
19	nCLK_EN	Input	Pulldown	Synchronizing clock enable. When LOW, clock outputs follow clock input. When HIGH, Q outputs are forced low, nQ outputs are forced high. LVTTTL / LVCMOS interface levels.

NOTE: *Pullup* and *Pulldown* refer to internal input resistors. See Table 2, *Pin Characteristics*, for typical values.

**Table 2. Pin Characteristics**

Symbol	Parameter	Test Conditions	Minimum	Typical	Maximum	Units
C <sub>IN</sub>	Input Capacitance			4		pF
R <sub>PULLUP</sub>	Input Pullup Resistor			51		kΩ
R <sub>PULLDOWN</sub>	Input Pulldown Resistor			51		kΩ

## Function Tables

**Table 3A. Control Input Function Table**

Inputs			Outputs	
nCLK_EN	CLK_SEL	Selected Source	Q[0:4]	nQ[0:4]
0	0	CLK0, nCLK0	Enabled	Enabled
0	1	CLK1, nCLK1	Enabled	Enabled
1	0	CLK0, nCLK0	Disabled; LOW	Disabled; HIGH
1	1	CLK1, nCLK1	Disabled; LOW	Disabled; HIGH

After nCLK\_EN switches, the clock outputs are disabled or enabled following a falling input clock edge as shown in *Figure 1*. In the active mode, the state of the outputs are a function of the CLK0, nCLK0 and CLK1, nCLK1 inputs as described in *Table 3B*.

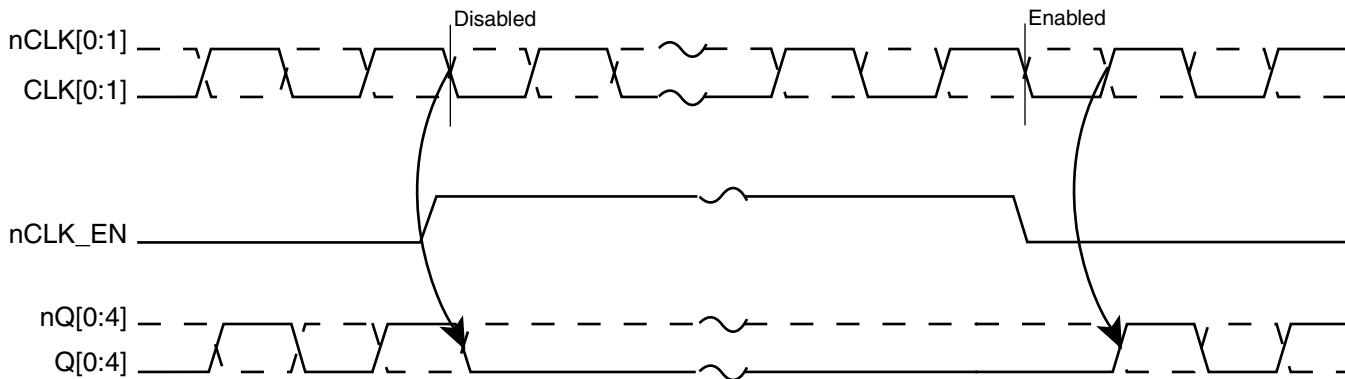

**Figure 1. nCLK\_EN Timing Diagram**

**Table 3B. Clock Input Function Table**

Inputs		Outputs		Input to Output Mode	Polarity
CLK0 or CLK1	nCLK0 or nCLK1	Q[0:4]	nQ[0:4]		
0	1	LOW	HIGH	Differential-to-Differential	Non-Inverting
1	0	HIGH	LOW	Differential-to-Differential	Non-Inverting

## Absolute Maximum Ratings

NOTE: Stresses beyond those listed under *Absolute Maximum Ratings* may cause permanent damage to the device. These ratings are stress specifications only. Functional operation of product at these conditions or any conditions beyond those listed in the *DC Characteristics* or *AC Characteristics* is not implied. Exposure to absolute maximum rating conditions for extended periods may affect product reliability.

Item	Rating
Supply Voltage, $V_{CC}$	4.6V
Inputs, $V_I$	-0.5V to $V_{CC} + 0.5V$
Outputs, $I_O$ Continuous Current Surge Current	50mA 100mA
Package Thermal Impedance, $\theta_{JA}$ 20 Lead SOIC 20 Lead TSSOP	46.2°C/W (0 lfpm) 73.2°C/W (0 lfpm)
Storage Temperature, $T_{STG}$	-65°C to 150°C

## DC Electrical Characteristics

**Table 4A. Power Supply DC Characteristics,  $V_{CC} = 2.375V$  to  $3.8V$ ;  $V_{EE} = 0V$ ,  $T_A = -40^\circ C$  to  $85^\circ C$**

Symbol	Parameter	Test Conditions	Minimum	Typical	Maximum	Units
$V_{CC}$	Positive Supply Voltage		2.375	3.3	3.8	V
$I_{EE}$	Power Supply Current				80	mA

**Table 4B. LVCMOS/LVTTL DC Characteristics,  $V_{CC} = 2.375V$  to  $3.8V$ ;  $V_{EE} = 0V$ ,  $T_A = -40^\circ C$  to  $85^\circ C$**

Symbol	Parameter	Test Conditions	Minimum	Typical	Maximum	Units
$V_{IH}$	Input High Voltage		2		$V_{CC} + 0.3$	V
$V_{IL}$	Input Low Voltage		-0.3		0.8	V
$I_{IH}$	Input High Current	nCLK_EN, CLK_SEL $V_{CC} = V_{IN} = 3.8V$			150	$\mu A$
$I_{IL}$	Input Low Current	nCLK_EN, CLK_SEL $V_{CC} = 3.8V, V_{IN} = 0V$	-5			$\mu A$

**Table 4C. Differential DC Characteristics,  $V_{CC} = 2.375V$  to  $3.8V$ ;  $V_{EE} = 0V$ ,  $T_A = -40^\circ C$  to  $85^\circ C$**

Symbol	Parameter	Test Conditions	Minimum	Typical	Maximum	Units
$I_{IH}$	Input High Current	CLK0, CLK1	$V_{CC} = V_{IN} = 3.8V$		150	$\mu A$
		nCLK0, nCLK1	$V_{CC} = V_{IN} = 3.8V$		5	$\mu A$
$I_{IL}$	Input Low Current	CLK0, CLK1	$V_{CC} = 3.8V, V_{IN} = 0V$	-5		$\mu A$
		nCLK0, nCLK1	$V_{CC} = 3.8V, V_{IN} = 0V$	-150		$\mu A$
$V_{PP}$	Peak-to-Peak Voltage; NOTE 1		0.15		1.3	V
$V_{CMR}$	Common Mode Range; NOTE 1, 2		0.5		$V_{CC} - 0.85$	V

NOTE 1:  $V_{IL}$  should not be less than -0.3V

NOTE 2: Common mode voltage is defined as  $V_{IH}$ .

**Table 4D. LVPECL DC Characteristics,  $V_{CC} = 2.375V$  to  $3.8V$ ;  $V_{EE} = 0V$ ,  $T_A = -40^{\circ}C$  to  $85^{\circ}C$** 

Symbol	Parameter	Test Conditions	Minimum	Typical	Maximum	Units
$V_{OH}$	Output High Voltage; NOTE 1		$V_{CC} - 1.4$		$V_{CC} - 0.9$	V
$V_{OL}$	Output Low Voltage; NOTE 1		$V_{CC} - 2.0$		$V_{CC} - 1.7$	V
$V_{SWING}$	Peak-to-Peak Output Voltage Swing		0.6		1.0	V

NOTE 1: Outputs termination with  $50\Omega$  to  $V_{CC} - 2V$ .

## AC Electrical Characteristics

**Table 5. AC Characteristics,  $V_{CC} = 2.375V$  to  $3.8V$ ;  $V_{EE} = 0V$ ,  $T_A = -40^{\circ}C$  to  $85^{\circ}C$** 

Symbol	Parameter	Test Conditions	Minimum	Typical	Maximum	Units
$f_{OUT}$	Output Frequency				700	MHz
$t_{PLH}$	Propagation Delay, Low to High; NOTE 1	$f \leq 700MHz$	1.0	1.4	1.8	ns
$t_{sk(o)}$	Output Skew; NOTE 2, 3				30	ps
$f_{jit}$	Buffer Additive Phase Jitter, RMS	156.25MHz, Integration Range: 12kHz - 20MHz		0.170	0.200	ps
		644.53125MHz, Integration Range: 12kHz - 20MHz		0.060	0.200	ps
$t_{sk(pp)}$	Part-to-Part Skew; NOTE 3, 4				350	ps
$t_S$	Setup Time	nCLK_EN to CLK	50			ps
$t_H$	Hold Time	nCLK_EN to CLK	50			ps
$t_R / t_F$	Output Rise/Fall Time	20% to 80%	200		700	ps
odc	Output Duty Cycle Skew	$f \leq 700MHz$	45		55	%

NOTE: All parameters measured at  $f_{OUT}$  unless otherwise noted.

NOTE: The cycle-to-cycle jitter on the input will equal the jitter on the output. The part does not add jitter.

NOTE: Electrical parameters are guaranteed over the specified ambient operating temperature range, which is established when the device is mounted in a test socket with maintained transverse airflow greater than 500 lfm. The device will meet specifications after thermal equilibrium has been reached under these conditions.

NOTE 1: Measured from the differential input crossing point to the differential output crossing point.

NOTE 2: Defined as skew between outputs at the same supply voltage and with equal load conditions.

NOTE 3: This parameter is defined in accordance with JEDEC Standard 65.

NOTE 4: Defined as skew between outputs on different devices operating at the same supply voltage, same temperature, same frequency and with equal load conditions. Using the same type of inputs on each device, the outputs are measured at the differential cross points.

## 156.25MHz Additive Phase Jitter

The spectral purity in a band at a specific offset from the fundamental compared to the power of the fundamental is called the ***dBc Phase Noise***. This value is normally expressed using a Phase noise plot and is most often the specified plot in many applications. Phase noise is defined as the ratio of the noise power present in a 1Hz band at a specified offset from the fundamental frequency to the power value of the fundamental. This ratio is expressed in decibels (dBm) or a ratio

of the power in the 1Hz band to the power in the fundamental. When the required offset is specified, the phase noise is called a ***dBc*** value, which simply means dBm at a specified offset from the fundamental. By investigating jitter in the frequency domain, we get a better understanding of its effects on the desired application over the entire time record of the signal. It is mathematically possible to calculate an expected bit error rate given a phase noise plot.

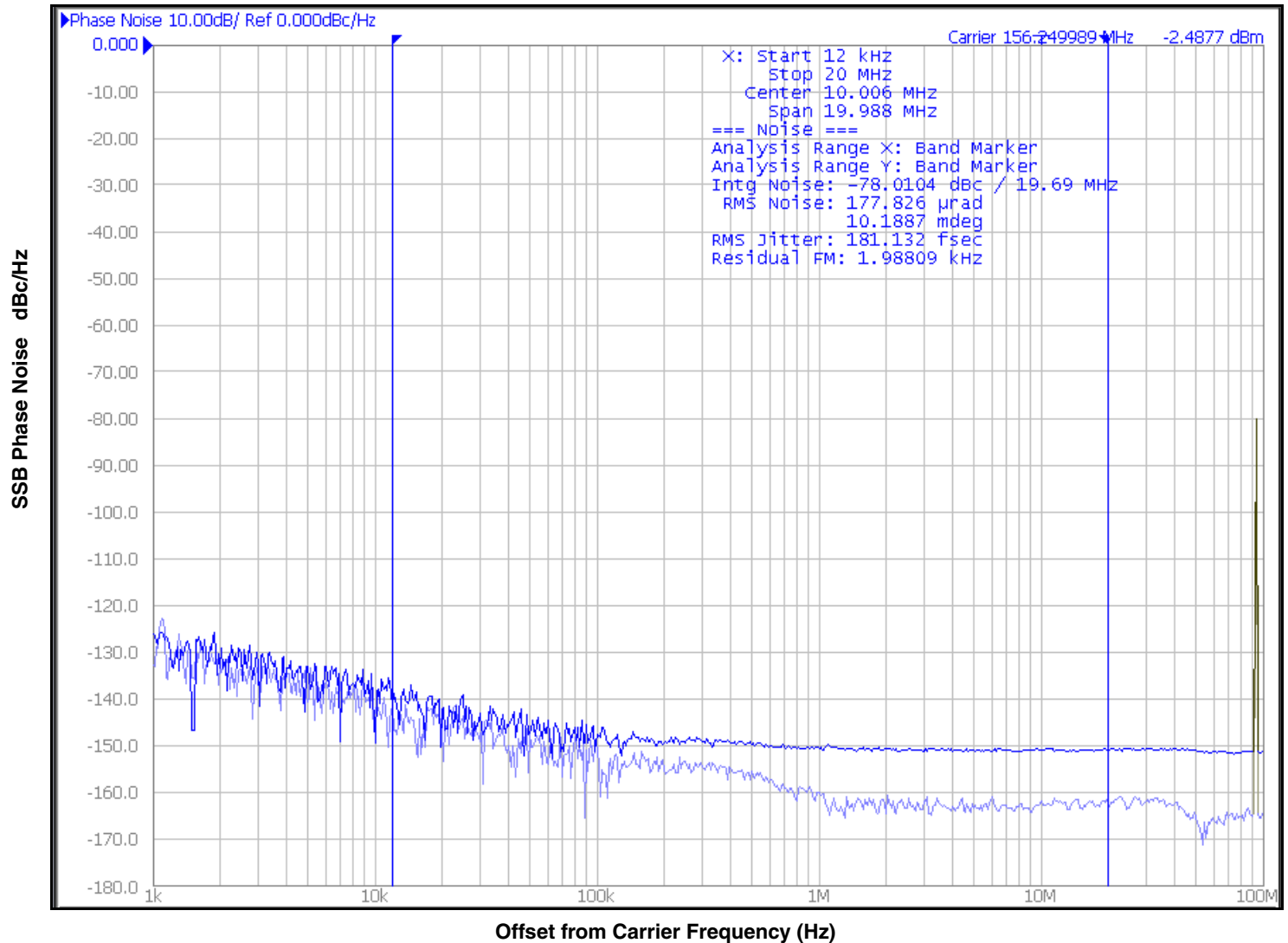

As with most timing specifications, phase noise measurements have issues relating to the limitations of the measurement equipment. The noise floor of the equipment can be higher or lower than the noise floor of the device. Additive phase noise is dependent on both the noise floor of the input source and measurement equipment.

Measured using a Rohde & Schwarz SMA100 as the input source.

## 644.53125MHz Additive Phase Jitter

The spectral purity in a band at a specific offset from the fundamental compared to the power of the fundamental is called the **dBc Phase Noise**. This value is normally expressed using a Phase noise plot and is most often the specified plot in many applications. Phase noise is defined as the ratio of the noise power present in a 1Hz band at a specified offset from the fundamental frequency to the power value of the fundamental. This ratio is expressed in decibels (dBm) or a ratio

of the power in the 1Hz band to the power in the fundamental. When the required offset is specified, the phase noise is called a **dBc** value, which simply means dBm at a specified offset from the fundamental. By investigating jitter in the frequency domain, we get a better understanding of its effects on the desired application over the entire time record of the signal. It is mathematically possible to calculate an expected bit error rate given a phase noise plot.

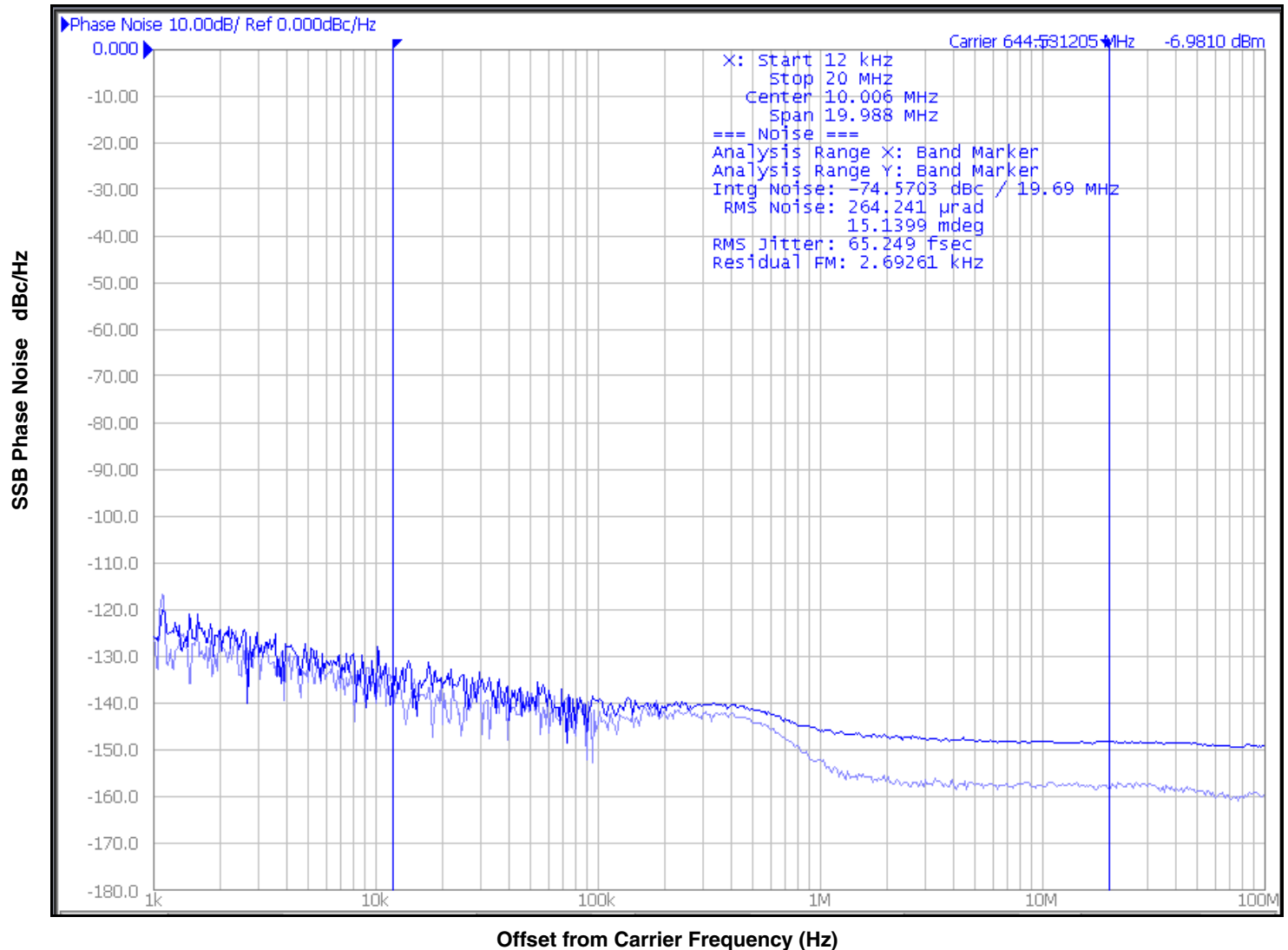

As with most timing specifications, phase noise measurements have issues relating to the limitations of the measurement equipment. The noise floor of the equipment can be higher or lower than the noise

floor of the device. Additive phase noise is dependent on both the noise floor of the input source and measurement equipment.

Measured using a Rohde & Schwarz SMA100 as the input source.

## Parameter Measurement Information

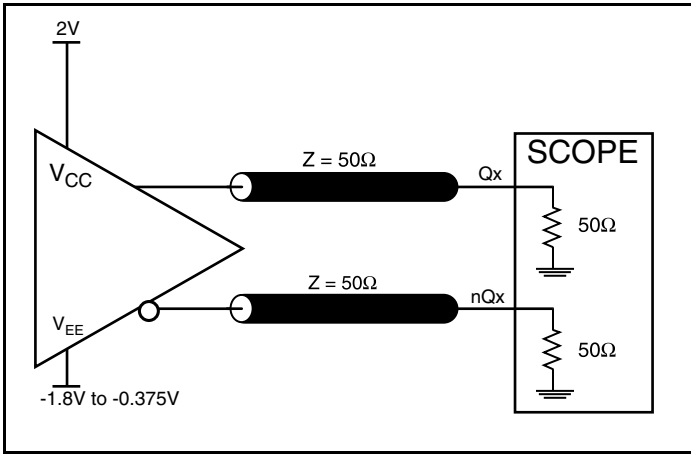

LVPECL Output Load Test Circuit

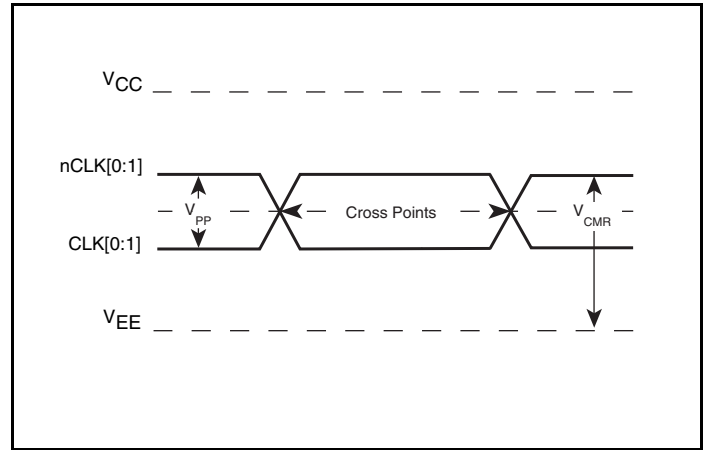

Differential Input Level

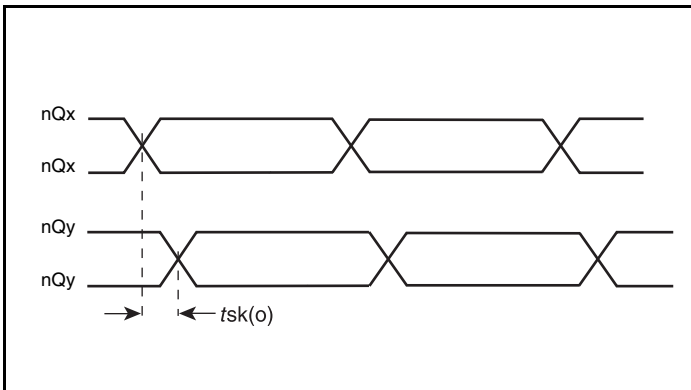

Output Skew

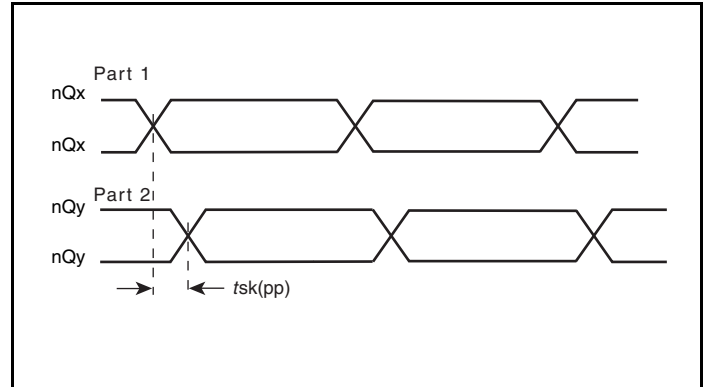

Part-to-Part Skew

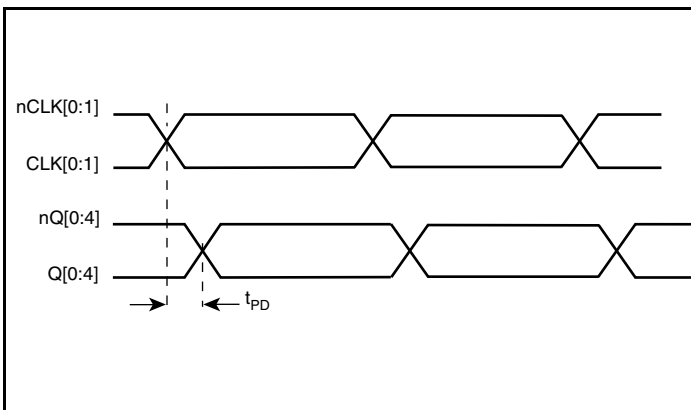

Propagation Delay

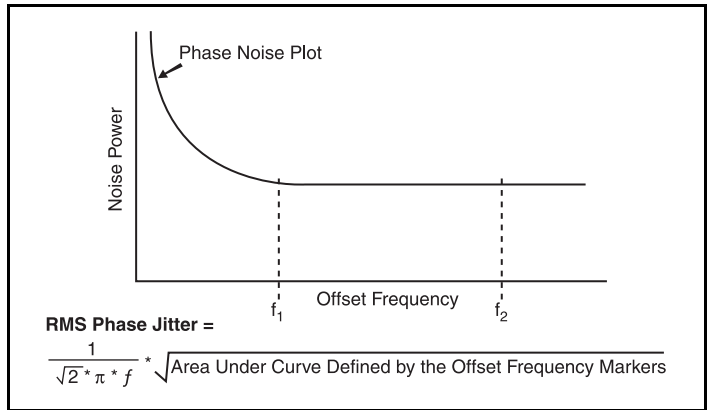

RMS Phase Jitter



## Parameter Measurement Information, continued

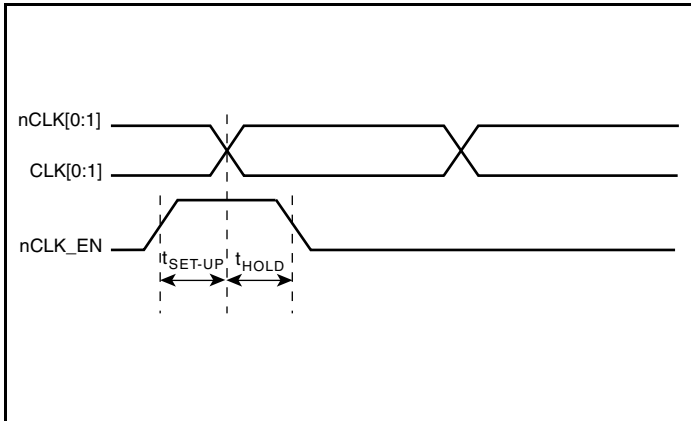

**Setup & Hold Time**

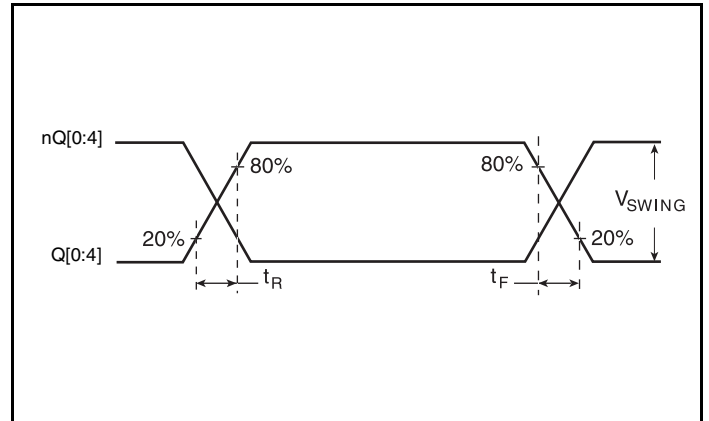

**Output Rise/Fall Time**

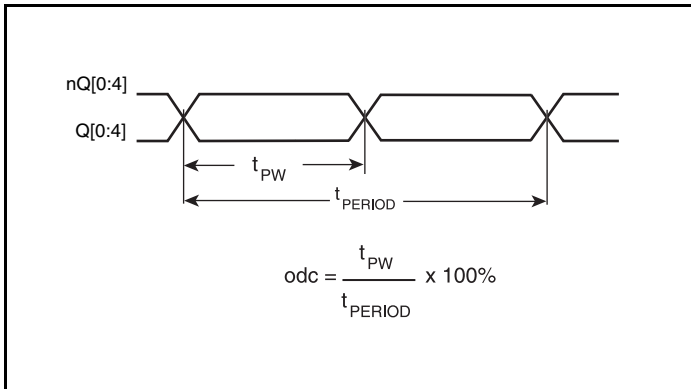

**Output Duty Cycle**

## Application Information

### Wiring the Differential Input to Accept Single-Ended Levels

Figure 2 shows how a differential input can be wired to accept single ended levels. The reference voltage  $V_1 = V_{CC}/2$  is generated by the bias resistors R1 and R2. The bypass capacitor (C1) is used to help filter noise on the DC bias. This bias circuit should be located as close to the input pin as possible. The ratio of R1 and R2 might need to be adjusted to position the  $V_1$  in the center of the input voltage swing. For example, if the input clock swing is 2.5V and  $V_{CC} = 3.3V$ , R1 and R2 value should be adjusted to set  $V_1$  at 1.25V. The values below are for when both the single ended swing and  $V_{CC}$  are at the same voltage. This configuration requires that the sum of the output impedance of the driver ( $R_o$ ) and the series resistance ( $R_s$ ) equals the transmission line impedance. In addition, matched termination at the input will attenuate the signal in half. This can be done in one of two ways. First, R3 and R4 in parallel should equal the transmission line

impedance. For most 50Ω applications, R3 and R4 can be 100Ω. The values of the resistors can be increased to reduce the loading for slower and weaker LVCMOS driver. When using single-ended signaling, the noise rejection benefits of differential signaling are reduced. Even though the differential input can handle full rail LVCMOS signaling, it is recommended that the amplitude be reduced. The datasheet specifies a lower differential amplitude, however this only applies to differential signals. For single-ended applications, the swing can be larger, however  $V_{IL}$  cannot be less than -0.3V and  $V_{IH}$  cannot be more than  $V_{CC} + 0.3V$ . Though some of the recommended components might not be used, the pads should be placed in the layout. They can be utilized for debugging purposes. The datasheet specifications are characterized and guaranteed by using a differential signal.

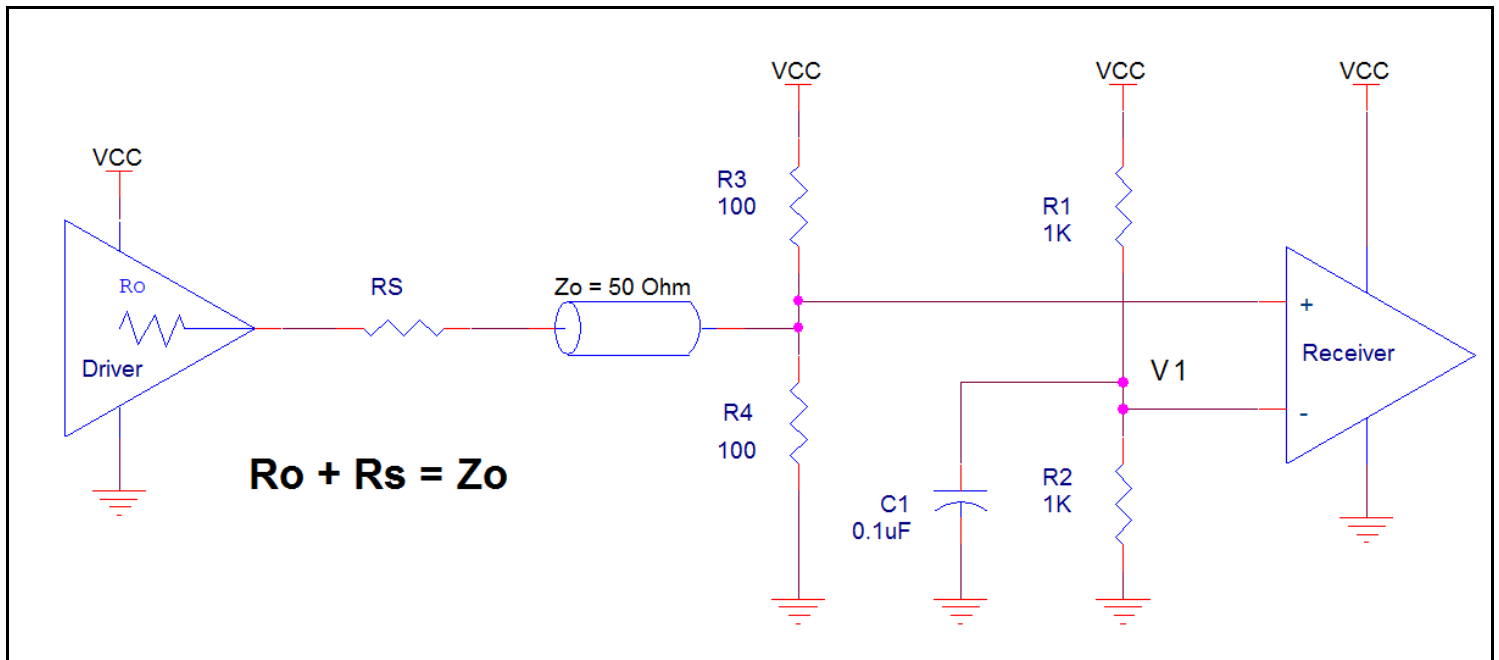

Figure 2. Recommended Schematic for Wiring a Differential Input to Accept Single-ended Levels

### Recommendations for Unused Input and Output Pins

#### Inputs:

##### CLK/nCLK Inputs

For applications not requiring the use of the differential input, both CLK and nCLK can be left floating. Though not required, but for additional protection, a 1kΩ resistor can be tied from CLK to ground.

##### Control Pins

All control pins have internal pull-down resistors; additional resistance is not required but can be added for additional protection. A 1kΩ resistor can be used.

#### Outputs:

##### LVPECL Outputs

All unused LVPECL outputs can be left floating. We recommend that there is no trace attached. Both sides of the differential output pair should either be left floating or terminated.

### 3.3V Differential Clock Input Interface

The CLK /nCLK accepts LVDS, LVPECL, LVHSTL, SSTL, HCSSL and other differential signals. Both  $V_{SWING}$  and  $V_{OH}$  must meet the  $V_{PP}$  and  $V_{CMR}$  input requirements. Figures 3A to 3F show interface examples for the CLK/nCLK input driven by the most common driver types. The input interfaces suggested here are examples

only. Please consult with the vendor of the driver component to confirm the driver termination requirements. For example in *Figure 3A*, the input termination applies for IDT LVHSTL drivers. If you are using an LVHSTL driver from another vendor, use their termination recommendation.

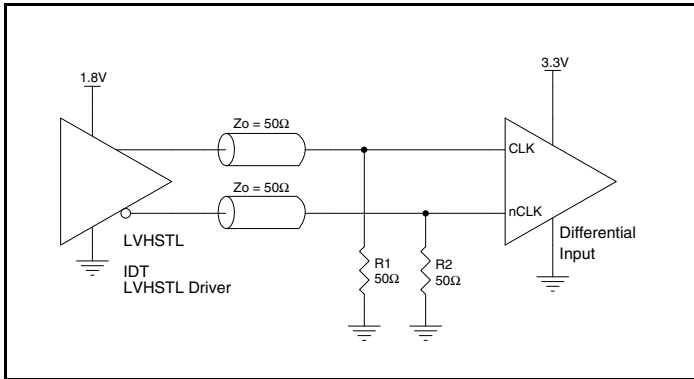

**Figure 3A. CLK/nCLK Input Driven by an IDT LVHSTL Driver**

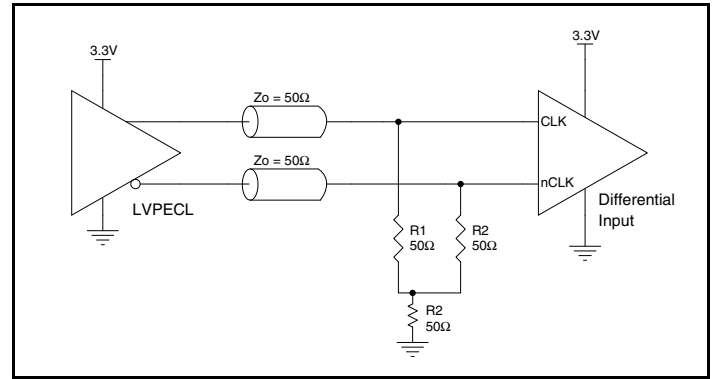

**Figure 3B. CLK/nCLK Input Driven by a 3.3V LVPECL Driver**

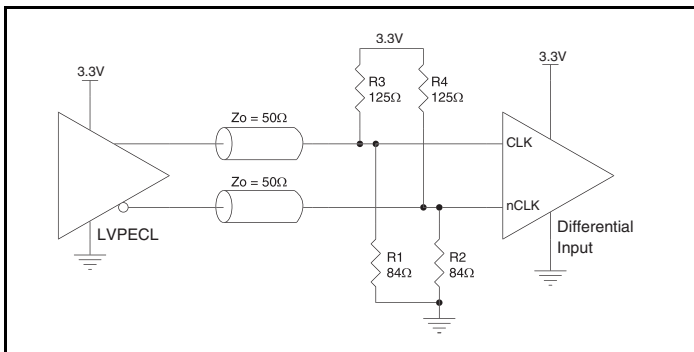

**Figure 3C. CLK/nCLK Input Driven by a 3.3V LVPECL Driver**

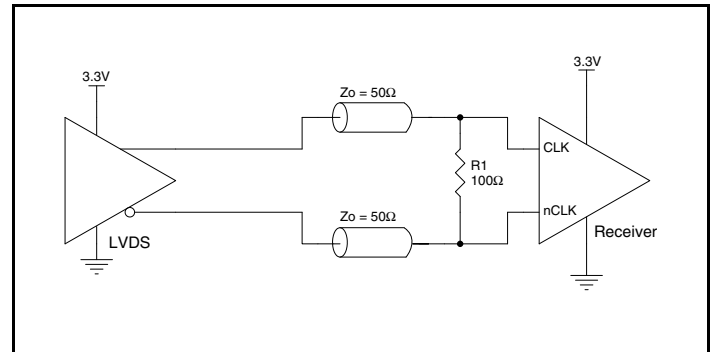

**Figure 3D. CLK/nCLK Input Driven by a 3.3V LVDS Driver**

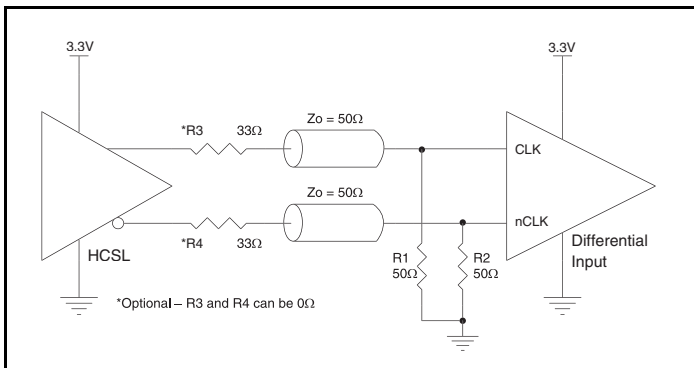

**Figure 3E. CLK/nCLK Input Driven by a 3.3V HCSSL Driver**

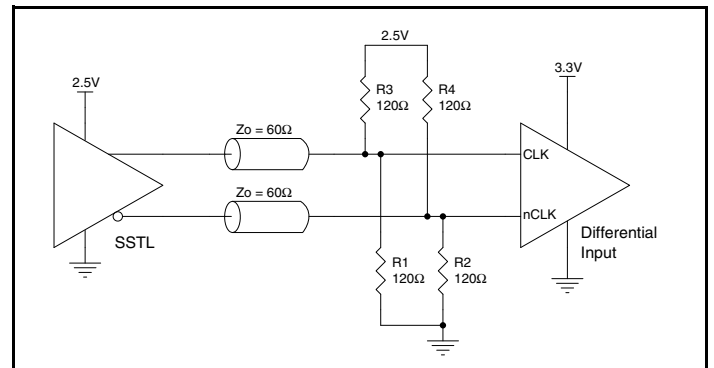
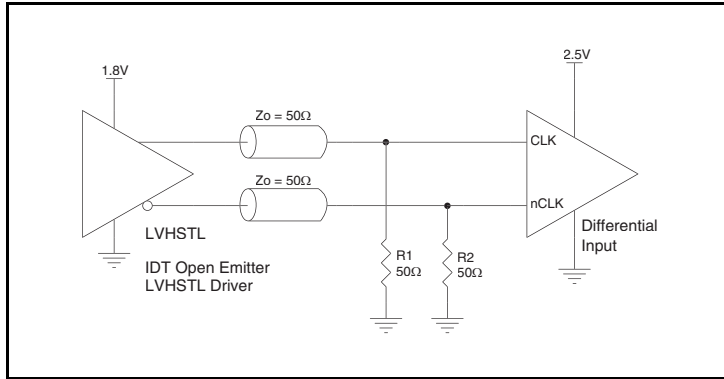

**Figure 3F. CLK/nCLK Input Driven by a 2.5V SSTL Driver**

## 2.5V Differential Clock Input Interface

The CLK/nCLK accepts LVDS, LVPECL, LVHSTL, SSTL, HCSL and other differential signals. Both  $V_{SWING}$  and  $V_{OH}$  must meet the  $V_{PP}$  and  $V_{CMR}$  input requirements. Figures 3A to 3F show interface examples for the CLK/nCLK input driven by the most common driver types. The input interfaces suggested here are examples only. Please consult

with the vendor of the driver component to confirm the driver termination requirements. For example in *Figure 3A*, the input termination applies for IDT LVHSTL drivers. If you are using an LVHSTL driver from another vendor, use their termination recommendation.



**Figure 3A.** CLK/nCLK Input Driven by an IDT LVHSTL Driver

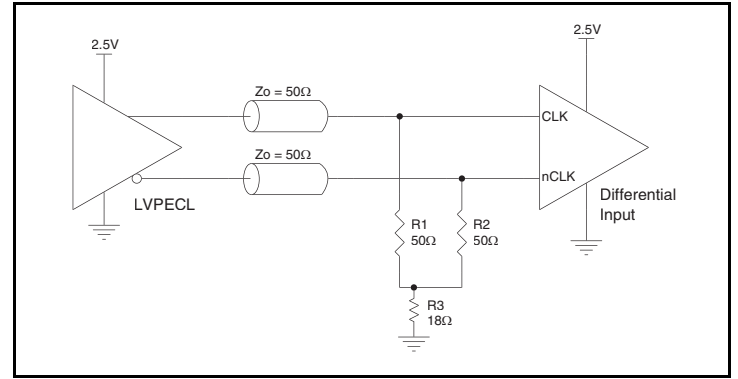

**Figure 3B.** CLK/nCLK Input Driven by a 2.5V LVPECL Driver

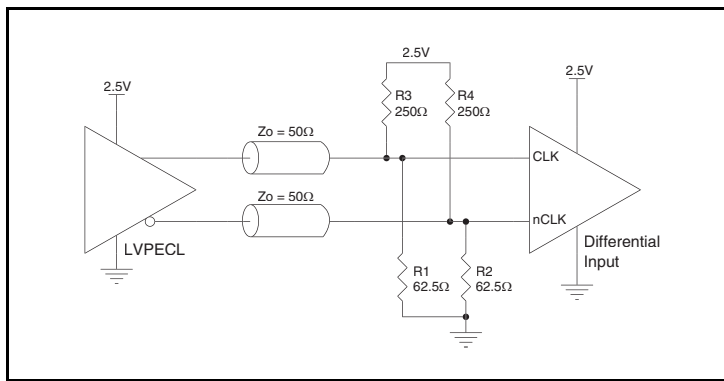

**Figure 3C.** CLK/nCLK Input Driven by a 2.5V LVPECL Driver

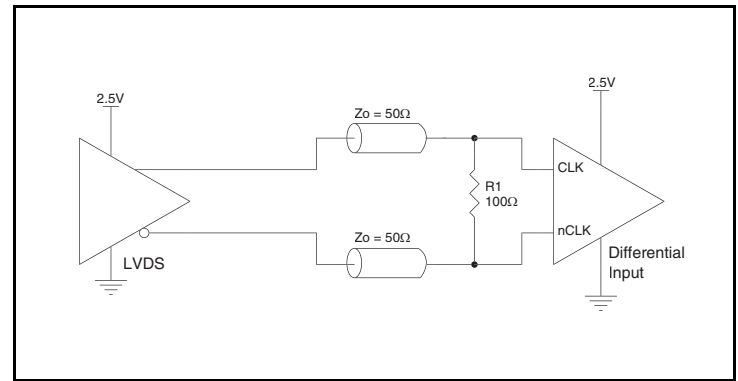

**Figure 3D.** CLK/nCLK Input Driven by a 2.5V LVDS Driver

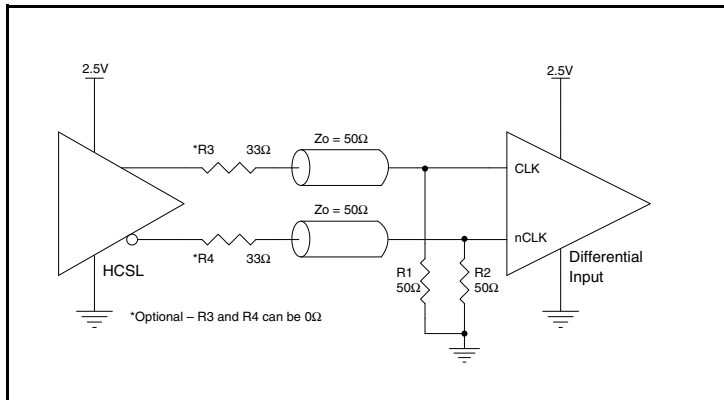

**Figure 3E.** CLK/nCLK Input Driven by a 2.5V HCSL Driver

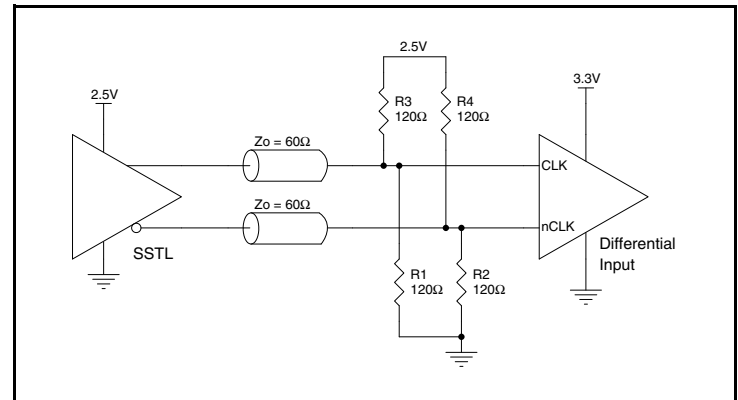

**Figure 3F.** CLK/nCLK Input Driven by a 2.5V SSTL Driver

## Termination for 3.3V LVPECL Outputs

The clock layout topology shown below is a typical termination for LVPECL outputs. The two different layouts mentioned are recommended only as guidelines.

The differential outputs are low impedance follower outputs that generate ECL/LVPECL compatible outputs. Therefore, terminating resistors (DC current path to ground) or current sources must be used for functionality. These outputs are designed to drive 50Ω

transmission lines. Matched impedance techniques should be used to maximize operating frequency and minimize signal distortion.

*Figures 5A and 5B* show two different layouts which are recommended only as guidelines. Other suitable clock layouts may exist and it would be recommended that the board designers simulate to guarantee compatibility across all printed circuit and clock component process variations.

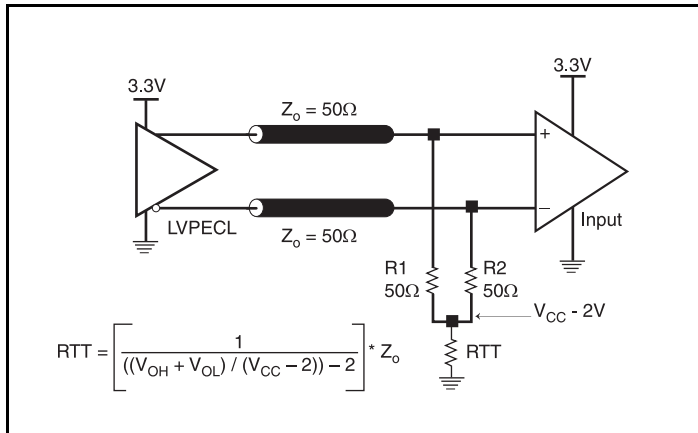

Figure 5A. 3.3V LVPECL Output Termination

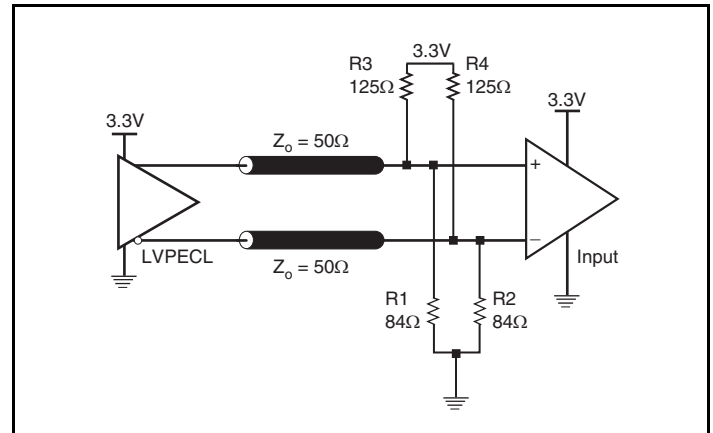

Figure 5B. 3.3V LVPECL Output Termination

## Termination for 2.5V LVPECL Outputs

Figure 6A and Figure 6B show examples of termination for 2.5V LVPECL driver. These terminations are equivalent to terminating  $50\Omega$  to  $V_{CC} - 2V$ . For  $V_{CC} = 2.5V$ , the  $V_{CC} - 2V$  is very close to ground

level. The R3 in Figure 6B can be eliminated and the termination is shown in Figure 6C.

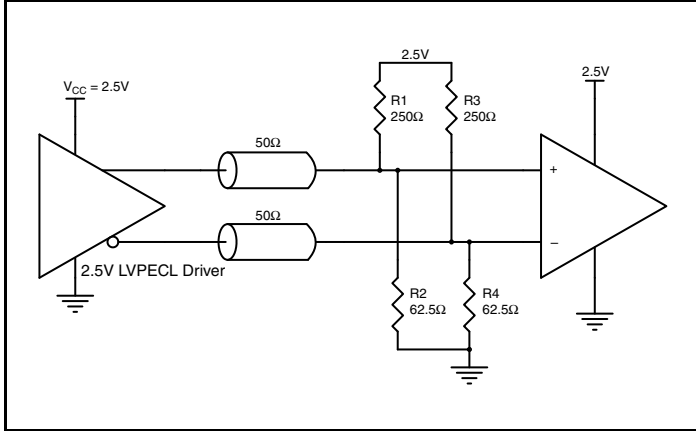

Figure 6A. 2.5V LVPECL Driver Termination Example

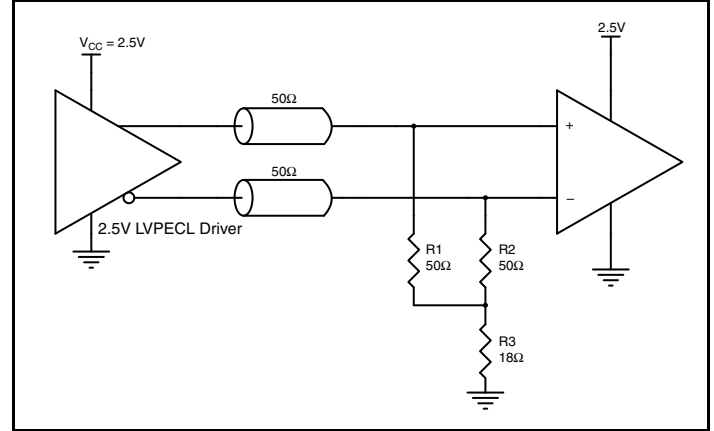

Figure 6B. 2.5V LVPECL Driver Termination Example

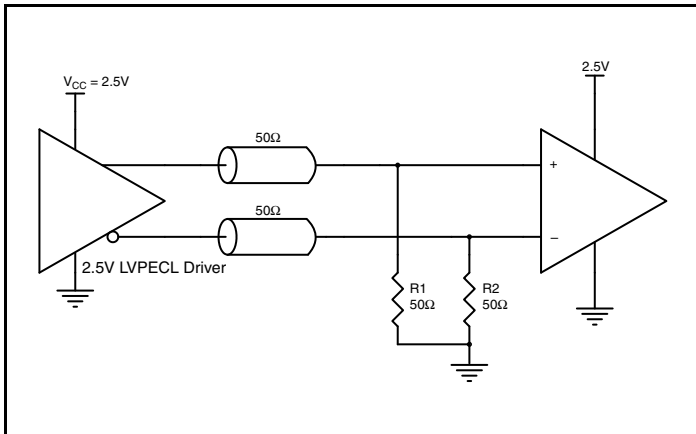

Figure 6C. 2.5V LVPECL Driver Termination Example

## Power Considerations

This section provides information on power dissipation and junction temperature for the ICS85314I-11. Equations and example calculations are also provided.

### 1. Power Dissipation.

The total power dissipation for the ICS85314I-11 is the sum of the core power plus the power dissipated due to loading. The following is the power dissipation for  $V_{CC} = 3.8V$ , which gives worst case results.

NOTE: Please refer to Section 3 for details on calculating power dissipated due to loading.

- Power (core)<sub>MAX</sub> =  $V_{CC\_MAX} * I_{EE\_MAX} = 3.8V * 80mA = 304mW$
- Power (outputs)<sub>MAX</sub> = **30mW/Loaded Output pair**  
If all outputs are loaded, the total power is  $5 * 30mW = 150mW$

**Total Power**<sub>MAX</sub> (3.6V, with all outputs switching) =  $304mW + 150mW = 454mW$

### 2. Junction Temperature.

Junction temperature,  $T_j$ , is the temperature at the junction of the bond wire and bond pad and it directly affects the reliability of the device. The maximum recommended junction temperature is 125°C. Limiting the internal transistor junction temperature,  $T_j$ , to 125°C ensures that the bond wire and bond pad temperature remains below 125°C.

The equation for  $T_j$  is as follows:  $T_j = \theta_{JA} * Pd_{total} + T_A$

$T_j$  = Junction Temperature

$\theta_{JA}$  = Junction-to-Ambient Thermal Resistance

$Pd_{total}$  = Total Device Power Dissipation (example calculation is in section 1 above)

$T_A$  = Ambient Temperature

In order to calculate junction temperature, the appropriate junction-to-ambient thermal resistance  $\theta_{JA}$  must be used. Assuming a moderate air flow or 200 linear feet per minute and a multi-layer board, the appropriate value is 66.6°C/W per Table 6B below.

Therefore,  $T_j$  for an ambient temperature of 85°C with all outputs switching is:

$$85^\circ C + 0.454W * 66.6^\circ C/W = 115^\circ C. \text{ This is well below the limit of } 125^\circ C.$$

This calculation is only an example.  $T_j$  will obviously vary depending on the number of loaded outputs, supply voltage, air flow and the type of board (multi-layer).

**Table 6A. Thermal Resistance  $\theta_{JA}$  for 20 Lead SOIC, Forced Convection**

Linear Feet per Minute	$\theta_{JA}$ by Velocity		
	0	200	500
Single-Layer PCB, JEDEC Standard Test Boards	83.2°C/W	65.7°C/W	57.5°C/W
Multi-Layer PCB, JEDEC Standard Test Boards	46.2°C/W	39.7°C/W	36.8°C/W

NOTE: Most modern PCB design use multi-layered boards. The data in the second row pertains to most designs.

**Table 6B. Thermal Resistance  $\theta_{JA}$  for 20 Lead TSSOP, Forced Convection**

Linear Feet per Minute	$\theta_{JA}$ by Velocity		
	0	200	500
Single-Layer PCB, JEDEC Standard Test Boards	114.5°C/W	98.0°C/W	88.0°C/W
Multi-Layer PCB, JEDEC Standard Test Boards	73.2°C/W	66.6°C/W	63.5°C/W

NOTE: Most modern PCB design use multi-layered boards. The data in the second row pertains to most designs.

### 3. Calculations and Equations.

The purpose of this section is to calculate the power dissipation for the LVPECL output pairs.

LVPECL output driver circuit and termination are shown in *Figure 7*.

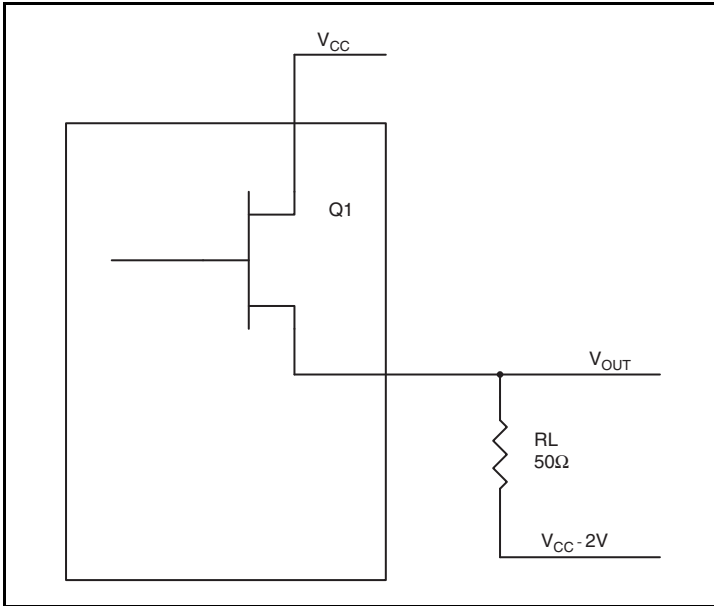

**Figure 7. LVPECL Driver Circuit and Termination**

To calculate power dissipation due to loading, use the following equations which assume a 50Ω load, and a termination voltage of  $V_{CC} - 2V$ .

- For logic high,  $V_{OUT} = V_{OH\_MAX} = V_{CC\_MAX} - 0.9V$   
( $V_{CC\_MAX} - V_{OH\_MAX}$ ) = **0.9V**
- For logic low,  $V_{OUT} = V_{OL\_MAX} = V_{CC\_MAX} - 1.7V$   
( $V_{CC\_MAX} - V_{OL\_MAX}$ ) = **1.7V**

$Pd\_H$  is power dissipation when the output drives high.

$Pd\_L$  is the power dissipation when the output drives low.

$$Pd\_H = [(V_{OH\_MAX} - (V_{CC\_MAX} - 2V))/R_L] * (V_{CC\_MAX} - V_{OH\_MAX}) = [(2V - (V_{CC\_MAX} - V_{OH\_MAX}))/R_L] * (V_{CC\_MAX} - V_{OH\_MAX}) = [(2V - 0.9V)/50\Omega] * 0.9V = \mathbf{19.8mW}$$

$$Pd\_L = [(V_{OL\_MAX} - (V_{CC\_MAX} - 2V))/R_L] * (V_{CC\_MAX} - V_{OL\_MAX}) = [(2V - (V_{CC\_MAX} - V_{OL\_MAX}))/R_L] * (V_{CC\_MAX} - V_{OL\_MAX}) = [(2V - 1.7V)/50\Omega] * 1.7V = \mathbf{10.2mW}$$

Total Power Dissipation per output pair =  $Pd\_H + Pd\_L = \mathbf{30mW}$



## Reliability Information

**Table 7A.  $\theta_{JA}$  vs. Air Flow Table for a 20 Lead SOIC, Forced Convection**

$\theta_{JA}$ by Velocity			
Linear Feet per Minute	0	200	500
Single-Layer PCB, JEDEC Standard Test Boards	83.2°C/W	65.7°C/W	57.5°C/W
Multi-Layer PCB, JEDEC Standard Test Boards	46.2°C/W	39.7°C/W	36.8°C/W

NOTE: Most modern PCB design use multi-layered boards. The data in the second row pertains to most designs.

**Table 7B.  $\theta_{JA}$  vs. Air Flow Table for a 20 Lead TSSOP, Forced Convection**

$\theta_{JA}$ by Velocity			
Linear Feet per Minute	0	200	500
Single-Layer PCB, JEDEC Standard Test Boards	114.5°C/W	98.0°C/W	88.0°C/W
Multi-Layer PCB, JEDEC Standard Test Boards	73.2°C/W	66.6°C/W	63.5°C/W

NOTE: Most modern PCB design use multi-layered boards. The data in the second row pertains to most designs.

## Transistor Count

The transistor count for ICS85314I-11 is: 674

## Package Outlines and Package Dimensions

Package Outline - G Suffix for 20 Lead TSSOP

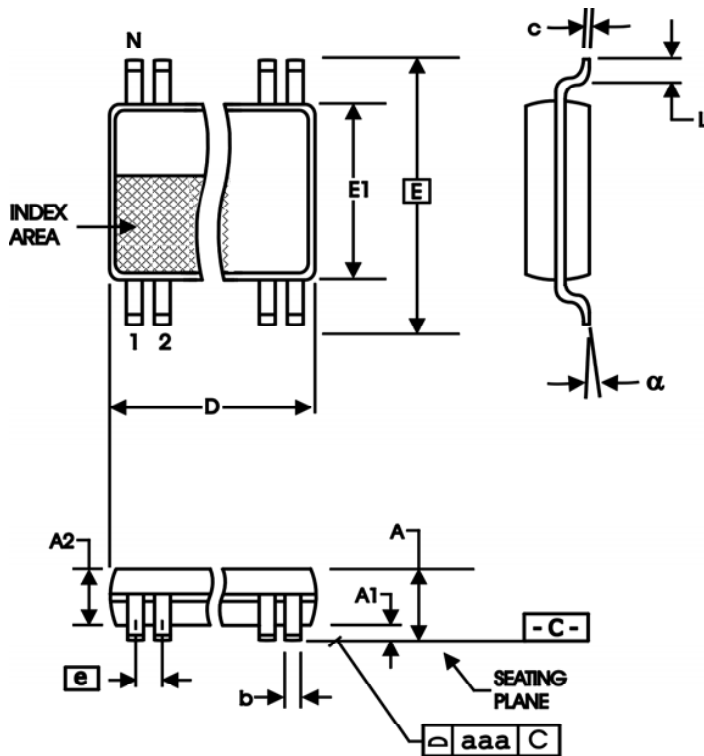

Package Outline - M Suffix for 20 Lead SOIC

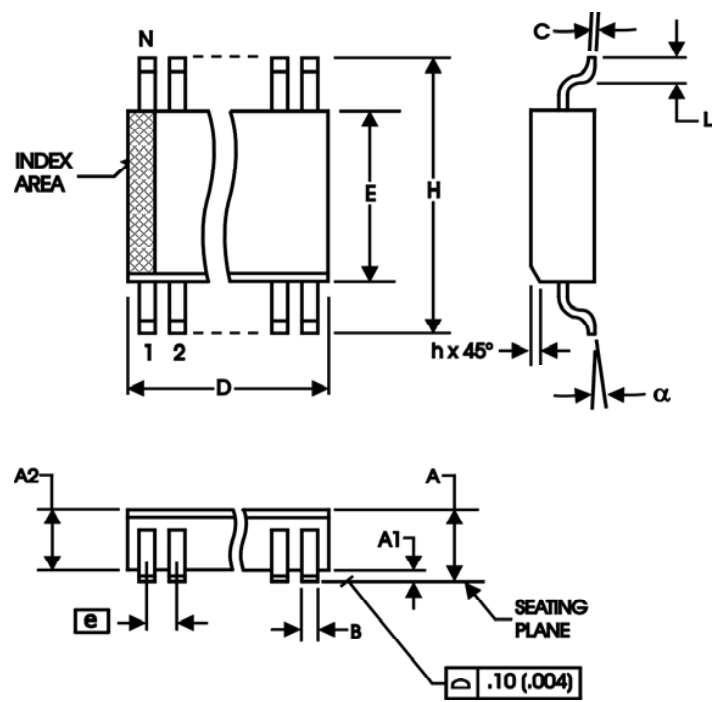

Table 8A. Package Dimensions

All Dimensions in Millimeters		
Symbol	Minimum	Maximum
N	20	
A		1.20
A1	0.05	0.15
A2	0.80	1.05
b	0.19	0.30
c	0.09	0.20
D	6.40	6.60
E	6.40 Basic	
E1	4.30	4.50
e	0.65 Basic	
L	0.45	0.75
$\alpha$	0°	8°
aaa		0.10

Reference Document: JEDEC Publication 95, MO-153

Table 8B. Package Dimensions for 20 Lead SOIC

300 Millimeters All Dimensions in Millimeters		
Symbol	Minimum	Maximum
N	20	
A		2.65
A1	0.10	
A2	2.05	2.55
B	0.33	0.51
C	0.18	0.32
D	12.60	13.00
E	7.40	7.60
e	1.27 Basic	
H	10.00	10.65
h	0.25	0.75
L	0.40	1.27
$\alpha$	0°	7°

Reference Document: JEDEC Publication 95, MS-013, MS-119

## Ordering Information

**Table 9. Ordering Information**

Part/Order Number	Marking	Package	Shipping Packaging	Temperature
85314AGI-11LF	ICS5314AI11L	"Lead-Free" 20 Lead TSSOP	Tube	-40°C to 85°C
85314AGI-11LFT	ICS5314AI11L	"Lead-Free" 20 Lead TSSOP	Tape & Reel	-40°C to 85°C
85314AMI-11LF	ICS85314AMI-11LF	"Lead-Free" 20 Lead SOIC	Tube	-40°C to 85°C
85314AMI-11LFT	ICS85314AMI-11LF	"Lead-Free" 20 Lead SOIC	Tape & Reel	-40°C to 85°C

## Revision History Sheet

Rev	Table	Page	Description of Change	Date
A	T1	2	Pin Description Table - Pin 14 & 17, nCLKx, deleted partial description and added Pullup in the "Type" column.	6/11/03
	T2	2	Pin Characteristics Table - C <sub>IN</sub> changed 4pF max. to 4pF typical.	
		4	AMR - corrected Output rating.	
		7	Added Wiring the Differential Input to Accept Single Ended Levels section.	
		8	Added Differential Clock Input Interface section.	
B	T5	1	Added Phase Noise bullet in Features section.	8/11/04
		5	AC Characteristics Table - added RMS Phase Jitter.	
		6	Added Phase Jitter Plot.	
		8	Updated Termination for 3.3V LVPECL Output diagrams.	
		9	Added Termination for 2.5V LVPECL Output section.	
B	T1	1	Features section - added Lead-Free bullet.	3/22/05
	T9	2	Pin Description Table - corrected CLK_SEL description.	
		16	Ordering Information Table - added ""Lead-Free"" part number for TSSOP package.	
C	T5	1	Features section - changed Part-to-Part Skew from 250ps max. to 350ps max.	5/24/05
		5	AC Characteristics table - changed Part-to-Part Skew from 250ps max. to 350ps max.	
D	T4D	5	LVPECL DC Characteristics Table - changed V <sub>OH</sub> max from V <sub>CC</sub> - 1.0V to V <sub>CC</sub> - 0.9V.	9/23/05
		8	Application Information Section - added Recommendations for Unused Input and Output Pins.	
E	T4C	4	Differential DC Characteristics Table - corrected typo in I <sub>IH</sub> row, nCLKx to 5uA from 150uA.	4/16/10
	T5	5	Added thermal note to AC Characteristics Table.	
	T9	9	Updated "Wiring the Differential Input to Accept Single-ended Levels" section.	
		17	Ordering Information Table - added LF marking for SOIC package. Converted datasheet format.	
E	T9	17	Ordering Information Table - corrected package in the Package Column.	5/4/10
F	T5	1	Features Section - updated packaging bullet. Deleted RMS Phase Noise bullet	9/16/13
		5	AC Characteristics Table - removed RMS Phase Noise specification, and added Buffer Additive Phase Jitter specifications.	
	6-7	Removed RMS Phase Noise Plot, and replaced with Additive Phase Jitter plots.		
	8	Parameter Measurement Information - corrected Phase Noise diagram.		
	10	Updated <i>Wiring the Differential Inputs to Accept Single-ended Levels</i> application note.		
	12	Added <i>2.5V Differential Clock Input Interface</i> application note.		
T9	19	Ordering Information Table - deleted leaded parts, deleted tape and reel count.		

## We've Got Your Timing Solution



6024 Silver Creek Valley Road  
San Jose, California 95138

### Sales

800-345-7015 (inside USA)  
+408-284-8200 (outside USA)  
Fax: 408-284-2775  
[www.IDT.com/go/contactIDT](http://www.IDT.com/go/contactIDT)

### Technical Support Sales

[netcom@idt.com](mailto:netcom@idt.com)  
+480-763-2056

DISCLAIMER Integrated Device Technology, Inc. (IDT) and its subsidiaries reserve the right to modify the products and/or specifications described herein at any time and at IDT's sole discretion. All information in this document, including descriptions of product features and performance, is subject to change without notice. Performance specifications and the operating parameters of the described products are determined in the independent state and are not guaranteed to perform the same way when installed in customer products. The information contained herein is provided without representation or warranty of any kind, whether express or implied, including, but not limited to, the suitability of IDT's products for any particular purpose, an implied warranty of merchantability, or non-infringement of the intellectual property rights of others. This document is presented only as a guide and does not convey any license under intellectual property rights of IDT or any third parties.

IDT's products are not intended for use in applications involving extreme environmental conditions or in life support systems or similar devices where the failure or malfunction of an IDT product can be reasonably expected to significantly affect the health or safety of users. Anyone using an IDT product in such a manner does so at their own risk, absent an express, written agreement by IDT.

Integrated Device Technology, IDT and the IDT logo are registered trademarks of IDT. Other trademarks and service marks used herein, including protected names, logos and designs, are the property of IDT or their respective third party owners.

Copyright 2013. All rights reserved.