

Rack-mounted DCS Signal Conditioners 18-RACK

STANDARD RACK

Functions & Features

- Standard 19" rack for 18-RACK signal conditioners
- Line power supplied via the rear rack bus
- Dual-redundant power supply or two independent power sources selectable with AC power supply
- Direct interface to various DCS with the rack connector

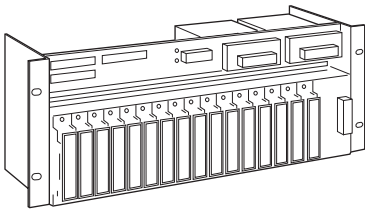

MODEL: 18BXE-[1]-[2][3]

ORDERING INFORMATION

- Code number: 18BXE-[1]-[2][3]

Specify a code from below for each [1] through [3].

(e.g. 18BXE-Y0-K2/M)

[1] CONNECTOR

0: None

U1: Fujitsu FCN type I/O connector

Y0: Yokogawa DCS connector

N1: Nippon Shokubai DCS connector

K1: Azbil DCS AI connector

K2: Azbil DCS AO connector

K3: Azbil DCS AI connector (ELCO connector)

K4: Azbil DCS AO connector (ELCO connector)

E1: Toshiba DCS SAMP1 card use

E2: Toshiba DCS SAOP1 card use

E3: Toshiba DCS SAIN1 card use

(Panasonic AXM220001 used)

(DISCONTINUED; replace with code "E3A".)

E3A: Toshiba DCS SAIN1 card supported

(Omron XG4A-2031 used)

M-System guarantees the connecting section.

[2] POWER SUPPLY UNIT

AC Power

K: 85 - 132 V AC; single power source

(Operational voltage range 85 - 132 V, 47 - 63 Hz)

K2: 85 - 132 V AC; dual-redundant power supply

(Operational voltage range 85 - 132 V, 47 - 63 Hz)

KK: 85 - 132 V AC; two independent power sources
(Operational voltage range 85 - 132 V, 47 - 63 Hz)

L: 170 - 264 V AC; single power source

(Operational voltage range 170 - 264 V, 47 - 63 Hz)

L2: 170 - 264 V AC; dual-redundant power supply

(Operational voltage range 170 - 264 V, 47 - 63 Hz)

DC Power

R: 24 V DC; no power supply unit

(Operational voltage range 24 V \pm 10 %, ripple 10 %p-p max.)

AC/DC Power

KR: 85 - 132 V AC / 24 V DC; two independent power sources

(85 - 132 V, 47 - 63 Hz or 24V \pm 10 %, ripple 10 %p-p max.)

(Redundant or independent power sources are

recommended for long time use without interruption.)

[3] OPTIONS

Mounting Bracket

blank: Rack mounting, standard

/M: Center mounting

/W: Surface mounting

RELATED PRODUCTS

- Blank filler plate (model: P-181)
- Connector terminal block (model: CNT)
- Special cable with 40-pin connector (model: FCN)

GENERAL SPECIFICATIONS

Construction: Metal plates assembly

Coating: Colored Zn-Cr

Capacity: 16 positions

Connection

Power input: M4 screw terminals (torque 0.8 N·m)

Power alarm output: M4 screw terminals (torque 0.8 N·m)

Screw terminal: Nickel-plated brass

Power alarm output: N.C. contact turns off at power failure or failure of power units. Supplied only with dual-redundant power supply or two independent power sources

Power RUN LED: Light turns on in normal conditions

(supplied only with dual-redundant power supply or two independent power sources)

OUTPUT SPECIFICATIONS

■ Alarm Output

Rated load: 250 V AC @ 3 A (cos ϕ = 1)

30 V DC @ 3 A (resistive load)

Maximum switching voltage: 250 V AC, 30 V DC

Maximum switching power: 750 VA, 90 W

Minimum load: 5 V DC @ 10 mA

Mechanical life: $\geq 5 \times 10^7$ cycles

INSTALLATION

Power consumption

- AC: 130 VA min.
- DC: 2.5 A min.

Operating temperature: -5 to +55°C (23 to 131°F) 0 to 50°C (32 to 122°F) for AC power

Operating humidity: 30 to 90 %RH (non-condensing)

Mounting: JIS or EIA standard rack or surface

Weight

Single power supply w/o power units:

- 3.5 kg (7.7 lb) with DC power type
- 4.0 kg (8.8 lb) with AC power type

Dual-redundant or two independent power sources:

- 4.0 kg (8.8 lb) with AC/DC power type
- 4.5 kg (9.9 lb) with AC/AC power type

PERFORMANCE

Insulation resistance: $\geq 100 \text{ M}\Omega$ with 500 V DC
(I/O connector to power to FG)

Dielectric strength: 500 V AC @ 1 minute
(I/O connector to power)

1500 V AC @ 1 minute (power to FG)

500 V AC @ 1 minute (1000 V for 24 V DC)

(I/O connector to FG)

MOUNTING REQUIREMENTS

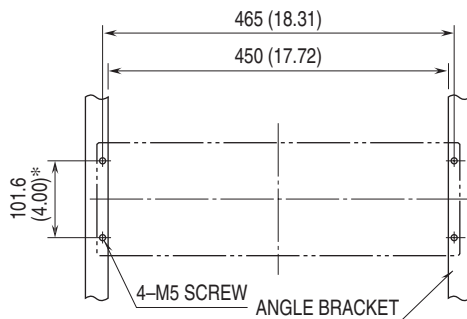

Observe an appropriate wiring space over and below.
*100 (3.94) for JIS standard

CONNECTION DIAGRAM

■ Single Power Source, Dual-redundant Power Supply

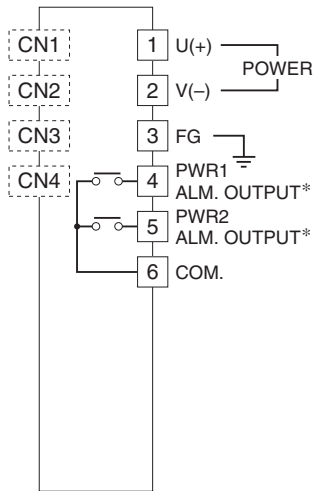

■ Two Independent Power Sources, DC/AC Power Supply

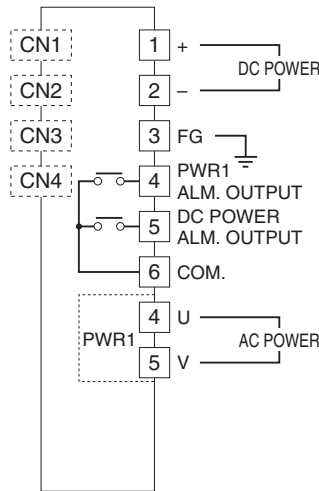

■ Two Independent Power Sources, AC/AC Power Supply

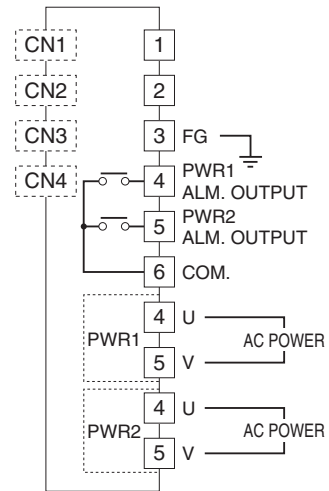

*Alarm output not provided for single power supply.

- Note 1: CN1 through CN4 are not available without connector.
- Note 2: CN2 is available with Yokogawa, Yamatake and Toshiba for DCS type.
- Note 3: CN3 is available with Yokogawa and Toshiba for DCS type.
- Note 4: CN4 is available with Toshiba for DCS type.

DIMENSIONS unit: mm (inch)

■ RACK (standard)

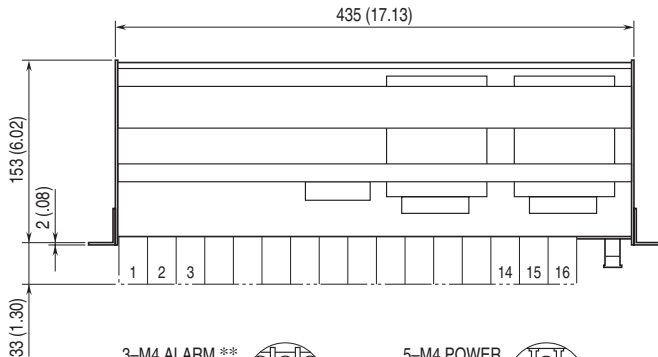

■ SURFACE (option /W)

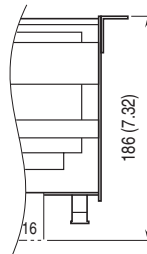

■ CENTER (option /M)

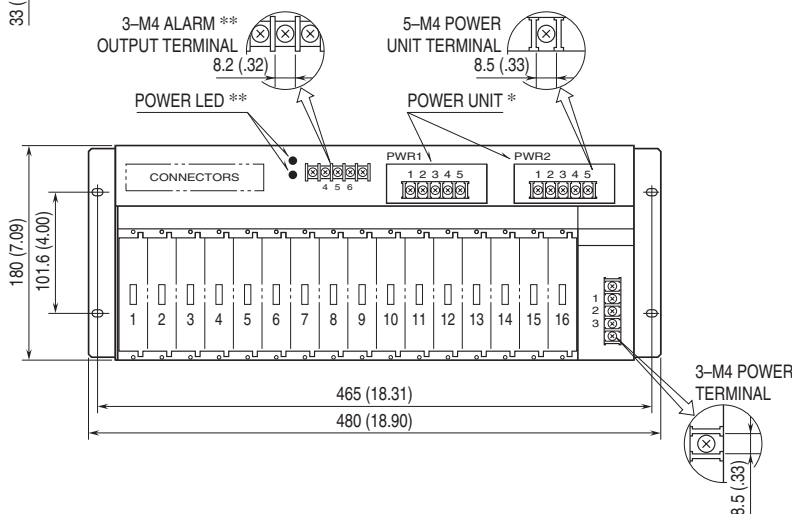
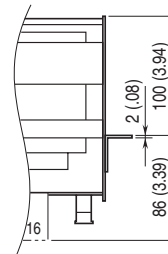

* PWR1 only for AC single power supply.

** Alarm output provided only for dual-redundant power supply or two independent power sources.

I/O CONNECTOR PIN ASSIGNMENT

•Fujitsu FCN type I/O connector

Connector pin assignment

CN1: FCN-364P040-AU

The input or output 1 is connected to the connector.

PIN NO.	ASSIGNMENT	PIN NO.	ASSIGNMENT
A 1	ch. 1 +	B 1	ch. 1 -
A 2	ch. 2 +	B 2	ch. 2 -
A 3	ch. 3 +	B 3	ch. 3 -
A 4	ch. 4 +	B 4	ch. 4 -
A 5	ch. 5 +	B 5	ch. 5 -
A 6	ch. 6 +	B 6	ch. 6 -
A 7	ch. 7 +	B 7	ch. 7 -
A 8	ch. 8 +	B 8	ch. 8 -
A 9	ch. 9 +	B 9	ch. 9 -
A10	ch.10 +	B10	ch.10 -
A11	ch.11 +	B11	ch.11 -
A12	ch.12 +	B12	ch.12 -
A13	ch.13 +	B13	ch.13 -
A14	ch.14 +	B14	ch.14 -
A15	ch.15 +	B15	ch.15 -
A16	ch.16 +	B16	ch.16 -

A17 - A20, B17 - B20: Unused

•Yokogawa DCS connector

Location

I/O connector: PS-40PE-D4T1-PN1

CN1: MAC2 / PAC card use*

CN2: MAC2 / PAC card use* for redundancy

CN3: VM □ / PM1 card use**

The input or output 1 is connected to the connector.

18-RACK LOCATION NO.															
1	2	3	4	5	6	7	8	9	10	11	12	13	14	15	16
VM1/PM1/VM4 CARD INPUT or OUTPUT CN3															
VM2 CARD INPUT NO. CN3								VM2 CARD OUTPUT NO. CN3							
1	1	2	2	3	3	4	4	5	5	6	6	7	7	8	8
i	o	i	o	i	o	i	o	i	o	i	o	i	o	i	o
MAC2/PAC CARD I/O (i = input, o = output) CN1, CN2															

*MAC2 card (uses KS1 cable)

I/O card used for control I/O. Composed of 8 inputs and 8 outputs. Input and output are paired. (Replace with pulse inputs for PAC card.)

**VM□ / PM1 card (uses KS2 cable)

VM1: analog input 16 points

VM2: analog input 8 points / analog output 8 points

VM4: analog output 16 points

PM1: pulse input 16 points

• Nippon Shokubai DCS connector

Location

CN1: HIF3F-34PA-2.54DSA

The input or output 1 is connected to the connector.

18-RACK LOCATION NO.															
1	2	3	4	5	6	7	8	9	10	11	12	13	14	15	16
NIPPON SHOKUBAI DCS LOCATION NO.															

Connector Pin Assignment

PIN NO.	ASSIGNMENT	PIN NO.	ASSIGNMENT
1	No Connection	19	ch. 8 -
2	No Connection	20	ch. 8 +
3	ch.16 -	21	ch. 7 -
4	ch.16 +	22	ch. 7 +
5	ch.15 -	23	ch. 6 -
6	ch.15 +	24	ch. 6 +
7	ch.14 -	25	ch. 5 -
8	ch.14 +	26	ch. 5 +
9	ch.13 -	27	ch. 4 -
10	ch.13 +	28	ch. 4 +
11	ch.12 -	29	ch. 3 -
12	ch.12 +	30	ch. 3 +
13	ch.11 -	31	ch. 2 -
14	ch.11 +	32	ch. 2 +
15	ch.10 -	33	ch. 1 -
16	ch.10 +	34	ch. 1 +
17	ch. 9 -		
18	ch. 9 +		

•Azbil DCS AI connector

I/O cable: J-RSL / J-RSK

J-RRL / J-RRK

Location

Input connector: 57GE-40500-751

CN1, CN2: J-HAM50 / J-HMM00 module use

The output 1 is connected to the connector. The CN1 and CN2 are connected in parallel.

18-RACK LOCATION NO.															
1	2	3	4	5	6	7	8	9	10	11	12	13	14	15	16
AZBIL DCS AI CONNECTOR															

•Azbil DCS AO connector

I/O cable: J-RSL / J-RSK
J-RRL / J-RRK

Location

Output connector: 57GE-40500-751

CN1, CN2: J-AOM10 module use

The input is connected to the connector. The CN1 and CN2 are connected in parallel.

Install the Extender Module (model: 18BW) to unused channels in order to close the circuit.

18-RACK LOCATION NO.															
1	2	3	4	5	6	7	8	9	10	11	12	13	14	15	16
1	2	3	4	5	6	7	8	9	10	11	12	13	14	15	16
AZBIL DCS AO CONNECTOR															

•Azbil DCS AI connector

I/O cable: J-SSL / J-SSK
J-SRL / J-SRK

Location

Input connector: 00-8016-056-296-707V

CN1, CN2: J-HAM50 / J-HMM00 module use

The output 1 is connected to the connector. The CN1 and CN2 are connected in parallel.

18-RACK LOCATION NO.															
1	2	3	4	5	6	7	8	9	10	11	12	13	14	15	16
1	2	3	4	5	6	7	8	9	10	11	12	13	14	15	16
AZBIL DCS AI CONNECTOR															

•Azbil DCS AO connector

I/O cable: J-SSL / J-SSK
J-SRL / J-SRK

Location

Output connector: 00-8016-056-296-707V

CN1, CN2: J-AOM10 module use

The input is connected to the connector. The CN1 and CN2 are connected in parallel.

Install the Extender Module (model: 18BW) to unused channels in order to close the circuit.

18-RACK LOCATION NO.															
1	2	3	4	5	6	7	8	9	10	11	12	13	14	15	16
1	2	3	4	5	6	7	8	9	10	11	12	13	14	15	16
AZBIL DCS AO CONNECTOR															

•Toshiba DCS SAMP1 card use

Location

Output connector: HIF3CA-40PA-2.54DSA (11)

CN1, CN2: SAMP1

CN3, CN4: SAMP1 for redundancy

The output 1 is connected to the connector.

18-RACK LOCATION NO.															
1	2	3	4	5	6	7	8	9	10	11	12	13	14	15	16
1	2	3	4	5	6	7	8	1	2	3	4	5	6	7	8
CN1, CN3								CN2, CN4							
SAMP1 INPUT POINT NO.															

•Toshiba DCS SAOP1 card use

Location

Input connector: HIF3CA-40PA-2.54DSA (11)

CN1, CN2: SAOP1

CN3, CN4: SAOP1 for redundancy

The input is connected to the connector.

18-RACK LOCATION NO.															
1	2	3	4	5	6	7	8	9	10	11	12	13	14	15	16
1	2	3	4	5	6	7	8	1	2	3	4	5	6	7	8
CN1, CN3								CN2, CN4							
SAOP1 OUTPUT POINT NO.															

•Toshiba DCS SAIN1 card use

Location

Input connector: Omron XG4A-2031

CN1 : SAIN1 (ch.1 – ch.8)

CN2 : SAIN1 (ch.1 – ch.8) for redundancy

CN3 : SAIN1 (ch.9 – ch.16)

CN4 : SAIN1 (ch.9 – ch.16) for redundancy

The output 1 is connected to the connector.

18-RACK LOCATION NO.															
1	2	3	4	5	6	7	8	9	10	11	12	13	14	15	16
1	2	3	4	5	6	7	8	1	2	3	4	5	6	7	8
CN1, CN2								CN3, CN4							
SAIN1 INPUT POINT NO.															

Toshiba DCS SAMP1 uses Panasonic AXM220001. As connector is discontinued, Omron XG4A-2031 is used as an alternative. (Replace cable side.)



Specifications are subject to change without notice.