



SUPER FAST GLASS PASSIVATED RECTIFIER

SF161C THRU SF166C

VOLTAGE RANGE

50 to 400 Volts

CURRENT

16.0 Ampere

FEATURES

- Super fast switching speed
- Glass passivated chip junction
- Low power loss, high efficiency
- Low leakage
- High surge capacity
- High temperature soldering guaranteed
250°C/10 second, 0.16" (4.06mm) lead length
- Also available with common Anode, add an "A" suffix,
i.e. SF161CA, add as a doubler, add a "D" suffix,
i.e. SF161CD
- Also available in an isolated package, SFF161C
- Also available in the single chip version, SF81

MECHANICAL DATA

- Case: Transfer molded plastic
- Epoxy: UL94V-0 rate flame retardant
- Lead: Solderable per MIL-STD-202E method 208C
- Polarity: as marked
- Mounting position: Any, 5 in-lbs Torque Max
- Weight: 0.08ounce, 2.24 gram

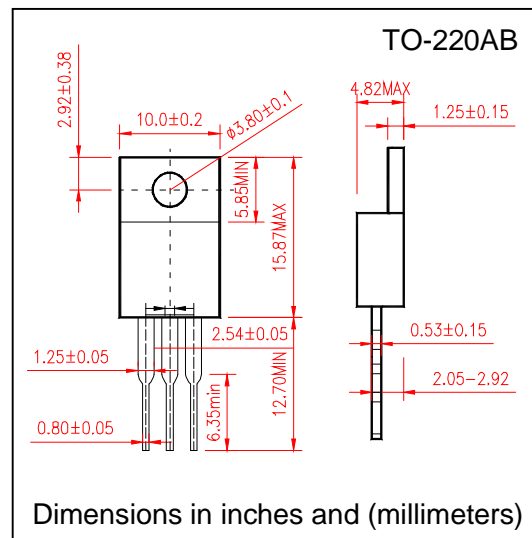

MAXIMUM RATINGS AND ELECTRICAL CHARACTERISTICS

- Ratings at 25°C ambient temperature unless otherwise specified
- Single Phase, half wave, 60Hz, resistive or inductive load
- For capacitive load derate current by 20%

| | SYMBOLS | SF161C | SF162C | SF163C | SF164C | SF165C | SF166C | UNIT |
|--|-----------------|---------------------------|--------|--------|--------|--------|--------|---------------------------|
| Maximum Repetitive Peak Reverse Voltage | V_{RRM} | 50 | 100 | 150 | 200 | 300 | 400 | Volts |
| Maximum RMS Voltage | V_{RMS} | 35 | 70 | 105 | 140 | 210 | 280 | Volts |
| Maximum DC Blocking Voltage | V_{DC} | 50 | 100 | 150 | 200 | 300 | 400 | Volts |
| Maximum Average Forward Rectified Current At $T_c=100^\circ\text{C}$ | $I_{(AV)}$ | 16.0 | | | | | | Amps |
| Peak Forward Surge Current 8.3ms single half sine wave superimposed on rated load (JEDEC method) | I_{FSM} | 125 | | | | | | Amps |
| Maximum Instantaneous Forward Voltage per at 8.0A | V_F | 0.975 | | | | 1.4 | | Volts |
| Maximum DC Reverse Current at rated DC Blocking Voltage at | I_R | $T_A = 25^\circ\text{C}$ | | | | | | μA |
| | | $T_A = 125^\circ\text{C}$ | | | | | | |
| Maximum Reverse Recovery Time Test conditions $I_F=0.5\text{A}$, $I_R=1.0\text{A}$, $I_{RR}=0.25\text{A}$ | t_{rr} | 35 | | | | 50 | | nS |
| Typical Junction Capacitance (Measured at 1.0MHz and applied reverse voltage of 4.0V) | C_j | 40 | | | | | | pF |
| Typical Thermal Resistance (Note 1) | $R_{\theta JC}$ | 2.5 | | | | | | $^\circ\text{C}/\text{W}$ |
| Operating Junction Temperature | T_j | (-55 to +150) | | | | | | $^\circ\text{C}$ |
| Storage Temperature Range | T_{STG} | (-55 to +150) | | | | | | $^\circ\text{C}$ |

Notes:

1. Unit mounted on heatsink



SUPER FAST GLASS PASSIVATED RECTIFIER

SF161C THRU SF166C

VOLTAGE RANGE 50 to 400 Volts
CURRENT 16.0 Ampere

RATING AND CHARACTERISTIC CURVES SF161C THRU SF166C

FIG.1-TYPICAL FORWARD CURRENT DERATING CURVE

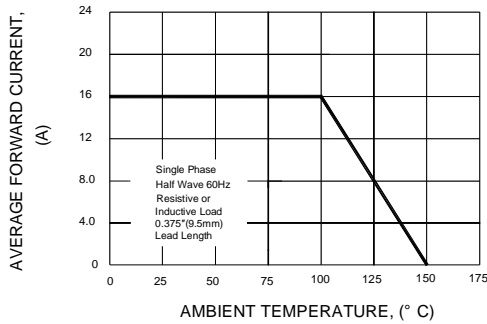

FIG.2-MAXIMUM NON-REPETITIVE PEAK FORWARD SURGE CURRENT

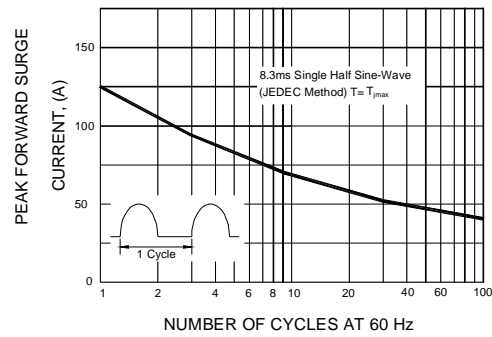

FIG.3-TYPICAL INSTANTANEOUS FORWARD CHARACTERISTICS PER LEG

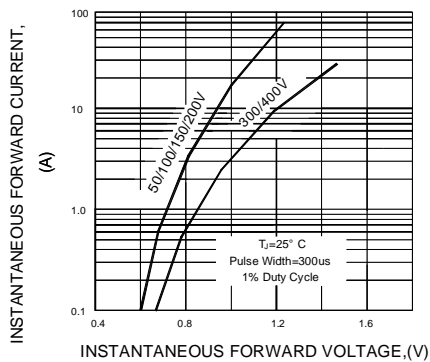

FIG.4-TYPICAL REVERSE CHARACTERISTICS PER LEG

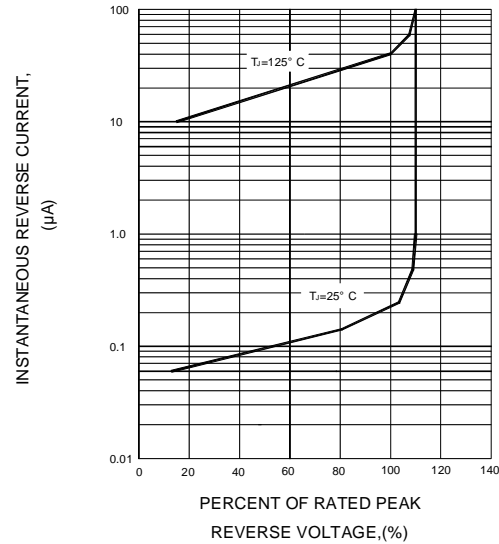

FIG.5-TYPICAL JUNCTION CAPACITANCE PER LEG

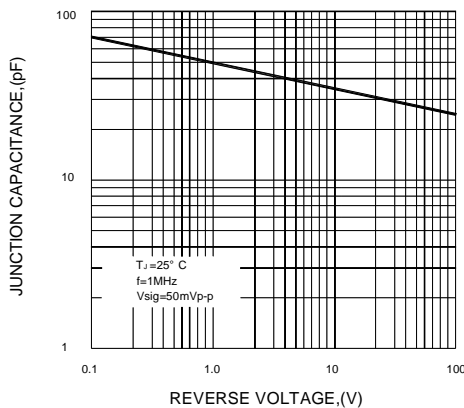
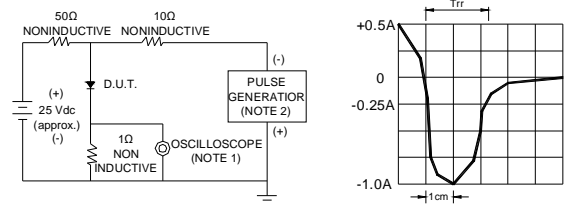

FIG.6-TEST CIRCUIT DIAGRAM AND REVERSE RECOVERY TIME CHARACTERISTIC



NOTES : 1.Rise Time=7ns max. Input Impedance= 1 magohm. 22pF
2.Rise time=10ns max. Source Impedance= 50 ohms

SET TIME BASE FOR 50/100ns/cm