

PWM SWITCHER & LINEAR CONTROLLER IC

FEATURES

- LDO Controller allows the use of a low cost pass transistor for the I/O supply
- 8 pin SOIC combines switching and linear controller
- Internal Pre-regulator Eliminates Cross talk between Switching & Linear regulators
- Automatic shut down of the linear regulator when connected to the Vcc2 Det pin
- On board MOSFET driver
- Fastest transient response of any controller method. (0 to 100% Duty Cycle in 100 nS)
- 1% internal voltage reference
- Internal Under Voltage Lockout protects MOSFET during start-up

APPLICATIONS

- Dual supply low voltage processor applications, such as: P55C™, CYRIX M2™, POWER PC™ and AMD K6™
- Simple 5V to 3.3V switcher for Pentium with AGP or Pentium II™ applications

DESCRIPTION

The US3033 IC combines a switching controller and a linear regulator controller all in a compact 8 pin surface mount package, providing a total solution for dual supply processor applications such as an Intel P55C™, AMD K6™, as well as Cyrix 6X86L™ and the M2™ processors. Typically in these applications a dual supply regulator converts 5V to 3.3V for I/O supply and a jumper programmable supply of 1.25V to 3.5V for CORE supply. The linear regulator controller portion in the US3033 is a programmable controller allowing flexibility for the I/O regulator and has a minimum of 50mA drive current capability designed to provide ample current for an external pass transistor. The IC uses an internal regulator generated from the 12V supply to power the controller as well as the 12V supply to drive the power MOSFET, allowing a low cost N channel MOSFET switch to be used. The IC also includes an error comparator for fast transient response, a precise voltage reference for setting the output voltage as well as a direct drive of the MOSFET for the minimum part count.

TYPICAL APPLICATION

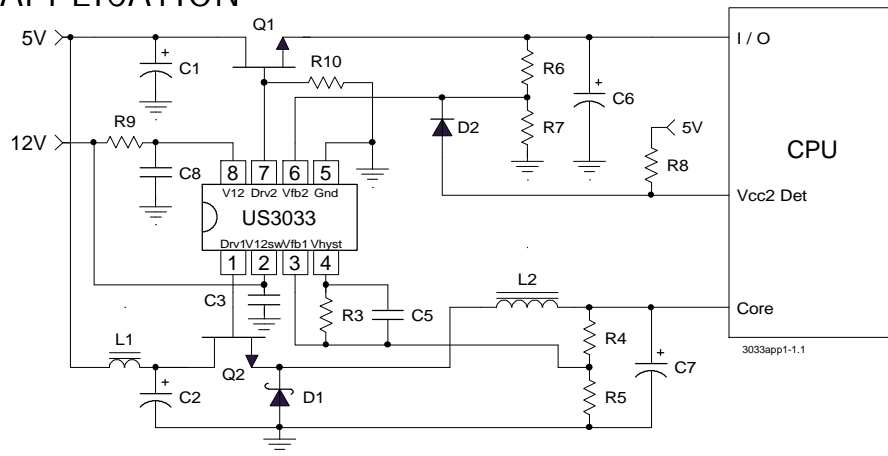

Typical application of US3033 in a flexible mother board designed for Intel P55™, P54™ AMD K5, K6™ as well as Cyrix M1™ and M2™ applications.

Notes: P54C, P55C, Pentium II are trade marks of Intel Corp. K5 & K6 are trade marks of AMD corp. Cyrix 6X86L, M1, M2 are trade marks of Cyrix Corp. Power PC is trade mark of IBM Corp.

PACKAGE ORDER INFORMATION

TA (°C)	8 PIN PLASTIC SOIC (S)
0 TO 70	US3033CS

US3033

ABSOLUTE MAXIMUM RATINGS

V_{12}, V_{12SW} Supply Voltages	20V
F.B Pin Voltages.....	-0.3V to 5V
Storage Temperature Range	-65 TO 150°C
Operating Junction Temperature	0 TO 150°C

PACKAGE INFORMATION

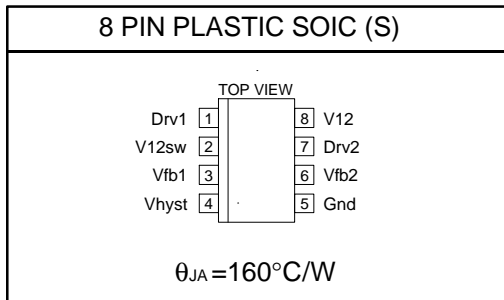

ELECTRICAL SPECIFICATIONS

Unless otherwise specified the following specification applies over $V_{12} = V_{12SW} = 12\text{V}$, and $T_A = 0$ to 70°C . Low duty cycle pulse testing are used which keeps junction and case temperatures equal to the ambient temperature.

Linear Controller Section

PARAMETER	SYM	TEST CONDITION	MIN	TYP	MAX	UNITS
F.B Voltage Initial Accuracy	V_{FB2}	$T_J = 25^{\circ}\text{C}$, $\text{Drv2} = V_{FB2}$, $C_L = 100\mu\text{F}$	1.237	1.250	1.262	V
F.B Voltage Total Variation		$\text{Drv2} = V_{FB2}$, $C_L = 100\mu\text{F}$	1.225	1.250	1.275	V
F.B Voltage Line Regulation		$10 < V_{12} < 14\text{V}$, $\text{Drv2} = V_{FB2}$, $C_L = 100\mu\text{F}$		0.2		%
F.B Input Bias Current	I_{FB2}	$V_{FB2} = 1.25\text{V}$	-1		+1	μA
Maximum Drive Current	I_{DRVMAX}	$V_{FB2} = 1\text{V}$, $V_{FB1} = 1.5\text{V}$		50		mA
V_{12} Supply Current	I_{12}	$V_{FB2} = 1\text{V}$, $V_{FB1} = 1.5\text{V}$, $I_{DRV2} = 0$		5		mA

Switching Controller Section

PARAMETER	SYM	TEST CONDITION	MIN	TYP	MAX	UNITS
F.B Voltage Initial Accuracy	V_{FB1}	$T_J = 25^{\circ}\text{C}$	1.237	1.250	1.262	V
F.B Voltage Total Variation			1.225	1.250	1.275	V
F.B Voltage Line Regulation				0.2		%
F.B Input Bias Current	I_{FB1}	$V_{FB1} = 1.25\text{V}$	-1		+1	μA
Min On Time		V_{FB1} is sq wave with 300 ns on time and 2 μs off time		800		nS
Min Off Time		V_{FB1} is sq wave with 300 ns off time and 2 μs on time		800		nS
Vhyst pin output-HI		$I_{SOURCE} = 500\mu\text{A}$, $V_{FB1} = 1.5\text{V}$	11			V
Vhyst pin output-LO		$I_{SINK} = 500\mu\text{A}$, $V_{FB1} = 1\text{V}$			1	V
Supply Current	I_{12SW}	$V_{FB1} = 1\text{V}$, $V_{FB2} = 1.5\text{V}$		10		mA
Maximum Duty Cycle	D_{MAX}	$V_{FB1} = 1\text{V}$			100	%
Minimum Duty Cycle	D_{MIN}	$V_{FB1} = 1.5\text{V}$	0			%
Gate Drive Rise/Fall Time	V_{GATE}	Load=IRL3303		70		nS

PIN DESCRIPTIONS

PIN #	PIN SYMBOL	PIN DESCRIPTION
3	V _{FB1}	A resistor divider from this pin to the output of the switching regulator and ground sets the Core supply voltage.
6	V _{FB2}	The feedback pin of the linear regulator. A resistor divider from this pin to the output of the linear regulator and ground sets the I/O supply voltage.
7	Drv2	The drive pin of the linear regulator. This pin controls the base of a transistor or the gate of a MOSFET acting as the series pass element for the linear regulator.
5	Gnd	This pin is connected to the IC substrate and must be connected to the lowest potential in the system.
1	Drv1	The PWM output of the switching controller. This pin is a totem pole drive that is connected to the gate of the power MOSFET. A resistor may be placed from this pin to the gate in order to reduce switching noise.
4	V _{HYST}	A resistor and a 10pF capacitor is connected from this pin to the V _{FB1} pin to set the output ripple voltage for the switching regulator.
2	V _{12SW}	This pin supplies the voltage to the PWM drive and hysteresis circuitry and it is connected to the 12V supply. A 1 uF, high frequency capacitor must be connected from this pin to ground to provide the peak current for charging and discharging of the MOSFET.
8	V ₁₂	This pin provides the biasing for the chip and drive for the linear regulator controller. It is connected to 12V supply. A 10 ohm resistor in series from this pin to the 12V supply and a 1uF, high frequency capacitor connected from this pin to Gnd is required to filter the switching noise of the switching regulator.

BLOCK DIAGRAM

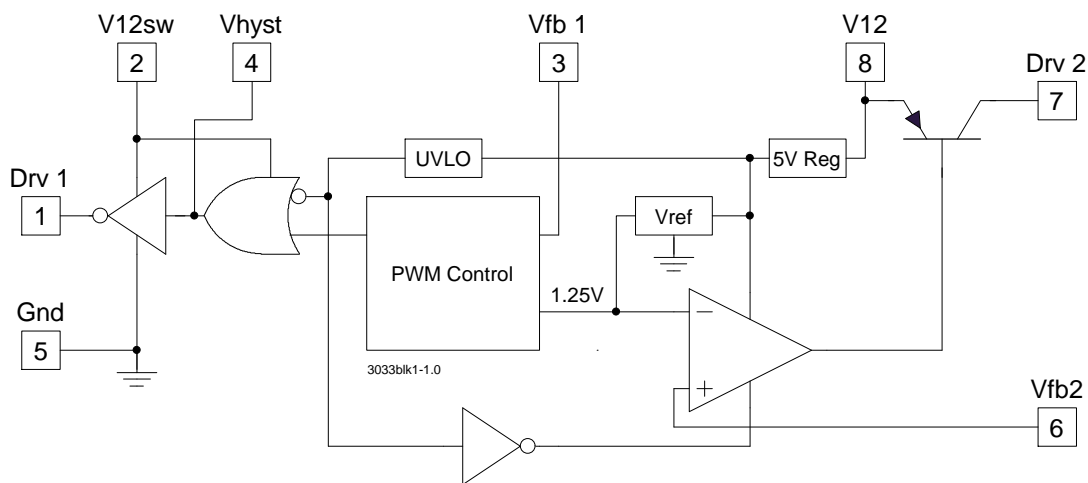

Figure 1 - Simplified block diagram of the US3033

US3033

TYPICAL APPLICATION

Pentium Dual Supply Application

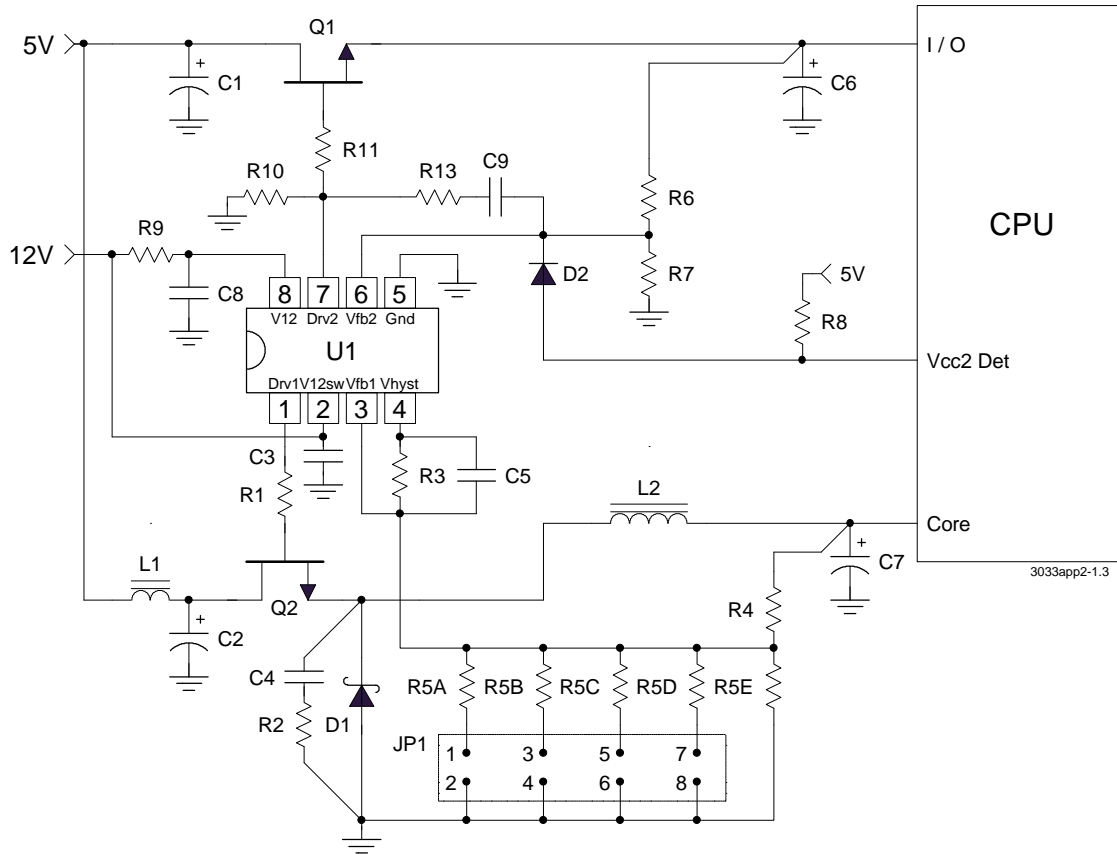

Figure 2- Typical application of US3033 in a flexible motherboard with the 4 bit VID output voltage selection. This circuit uses a single jumper that programs the output voltage in 16 steps with 0.1V steps from 2V to 3.5V, designed for Intel P55™, P54™, AMD K5 & K6™ as well as Cyrix M1™ and M2™ applications. The Vcc2Det pin automatically shuts down the I/O regulator when a single plane processor is dropped in the socket.

JP1	JP1	JP1	JP1	Output Voltage
1-2	3-4	5-6	7-8	
0	0	0	0	3.5
0	0	0	1	3.4
0	0	1	0	3.3
0	0	1	1	3.2
0	1	0	0	3.1
0	1	0	1	3.0
0	1	1	0	2.9
0	1	1	1	2.8
1	0	0	0	2.7
1	0	0	1	2.6
1	0	1	0	2.5
1	0	1	1	2.4
1	1	0	0	2.3
1	1	0	1	2.2
1	1	1	0	2.1
1	1	1	1	2.0

0 = Jumper block is installed.
1 = Jumper block is not installed.

Pentium Dual Supply Application Parts List

Ref Desig	Description	Qty	Part #	Manufacturer
U1	LDO/Switcher IC	1	US3033CS (8 pin SOIC)	Unisem
Q1	MOSFET	1	MTP3055 (TO220)	Motorola
Q2	MOSFET	1	IRL3303 (TO220) IRL3103S (TO263) (note 1)	International Rectifier
D2	Diode, GP	1	1N4148	
D1	Schottky Diode	1	MBR1045CT (TO220) MBRB1545CT (TO263) (note1)	Motorola
L2	Inductor	1	Core:T50-18,L=4 uH Turns: 10T, 18 AWG	Micro Metal (core)
L1	Inductor	1	L=2 uH	
R1	Resistor	1	22 ohm,5%, SMT 1206 size	
R2	Resistor	1	10 ohm, 5%, SMT 1206 size	
R3	Resistor	1	324 kohm,1%, SMT 0805 size	
R4A *	Resistor	1	806 ohm,1%, SMT 0805 size	
R4B *	Resistor	1	90.9 kohm,1%, SMT 0805 size	
R5A	Resistor	1	1.24 kohm,1%, SMT 0805 size	
R5B	Resistor	1	2.49 kohm,1%, SMT 0805 size	
R5C	Resistor	1	4.99 kohm,1%, SMT 0805 size	
R5D	Resistor	1	10 kohm,1%, SMT 0805 size	
R5E	Resistor	1	1.30 kohm,1%, SMT 0805 size	
R6	Resistor	1	2k ohm,1%, SMT 0805 size	
R7	Resistor	1	1.21k ohm,1%, SMT 0805 size	
R8	Resistor	1	1 kohm,5%, SMT 0805 size	
R9	Resistor	1	10 ohm,5%, SMT 0805 size	
R10	Resistor	1	1k ohm,5%, SMT 0805 size	
R11	Resistor	1	2.4k ohm,5%, SMT 0805 size	
R13	Resistor	1	7.5k ohm,5%, SMT 0805 size	
C1	Capacitor	1	6MV1500GX, 1500uF,6.3V, Elect	
C2	Capacitor	1	6MV1500GX, 1500uF,6.3V, Elect	Sanyo
C3	Capacitor	1	1 uF,Ceramic, SMT 0805 size	
C4	Capacitor	1	470 pF,Ceramic, SMT 0805 size	Sanyo
C5	Capacitor	1	10 pF,Ceramic, SMT 0805 size	Sanyo
C6	Capacitor	1	6MV1500GX, 1500uF,6.3V, Elect	Sanyo
C7	Capacitor	4	6MV1500GX, 1500uF,6.3V, Elect	Sanyo
C8	Capacitor	1	1 uF,Ceramic, SMT 0805 size	
C9	Capacitor	1	470pF ,Ceramic, SMT 0805 size	
HS1	Heat Sink	1	For MOSFET , 577002	Aavid
HS2	Heat Sink	1	For Schottky Diode , 577002	Aavid
HS3	Heat Sink	1	For Q1 , 507222 (I/O curren<5A) 576602 (I/O current< 3.5A)	Aavid

* R4 is a parallel combination of R4A and R4B.

Note 1: For the applications where it is desirable to eliminate the heat sink, the IRL3103S for Q2 and MBR1545CT for D2 in TO263 packages with minimum of 1" square copper pad can be used.

US3033

TYPICAL APPLICATION

**5V to 3.3V for Pentium Application with AGP or Pentium II Application without ATX power supply
Dual mode Operation between Switching or Linear mode.**

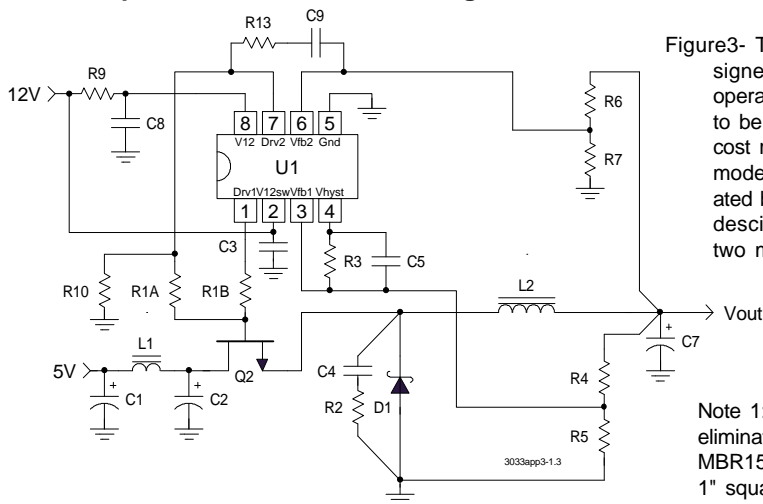

Figure3- This unique application of US3033 allows the designer to switch between Linear or Switching mode of operation using a single IC. This circuit has the flexibility to be used for low current operation in Linear mode for cost reasons and yet be able to operate in the Switching mode if the load current increases and the heat generated by the Linear operation will be an issue. Table below describes the components that will be effected for the two modes of operation.

Note 1: For the applications where it is desirable to eliminate the heat sink, the IRL3103S for Q2 and MBR1545CT for D2 in TO263 packages with minimum of 1" square copper pad can be used.

Mode of Operation	L1	L2	D1	C4	C5	R1A	R1B	R2	R3	R4	R5	R6	R7
Switching	V	V	V	V	V	O	V	V	V	V	V	V	O
Linear	S	S	O	O	O	V	O	O	O	V	O	V	V

V = See parts list for value S = Short O = Open

Ref Desig	Description	Qty	Part #	Manufacturer
U1	LDO/Switcher IC	1	US3033CS (8 pin SOIC)	Unisem
Q2	MOSFET	1	IRL3303 (TO220) IRL3103S (TO263) (note 1)	International Rectifier
D1	Schottky Diode	1	MBR1045CT (TO220) MBRB1545CT (TO263) (note1)	Motorola
L2	Inductor	1	Core:T50-18,L=4 uH Turns: 10T, 18 AWG	Micro Metal (core)
L1	Inductor	1	L=2 uH	
R1A	Resistor	1	2.4k ohm,5%, SMT 1206 size	
R1B	Resistor	1	22 ohm,5%, SMT 1206 size	
R2	Resistor	1	10 ohm, 5%, SMT 1206 size	
R3	Resistor	1	249 kohm,1%, SMT 0805 size	
R4	Resistor	1	1 kohm,1%, SMT 0805 size	
R5	Resistor	1	576 ohm,1%, SMT 0805 size	
R6	Resistor	1	180 ohm,1%, SMT 0805 size	
R7	Resistor	1	100 ohm,1%, SMT 0805 size	
R9	Resistor	1	10 ohm, 5%, SMT 1206 size	
R10	Resistor	1	1k ohm, 5%, SMT 1206 size	
R13	Resistor	1	7.5k ohm, 5%, SMT 1206 size	
C1,2	Capacitor	2	6MV1500GX, 1500uF,6.3V, Elect	Sanyo
C3	Capacitor	1	1 uF,Ceramic, SMT 0805 size	
C4	Capacitor	1	470 pF,Ceramic, SMT 0805 size	Sanyo
C5	Capacitor	1	10 pF,Ceramic, SMT 0805 size	Sanyo
C7	Capacitor	1	6MV1500GX, 1500uF,6.3V, Elect	Sanyo
C8	Capacitor	1	1 uF,Ceramic, SMT 0805 size	
C9	Capacitor	1	470pF,Ceramic, SMT 0805 size	
HS1	Heat Sink	1	For MOSFET in Switching mode , 577002 For MOSFET in Linear mode : 507222 (3.3V current<5A), 576602 (3.3V current< 3.5A)	Aavid
HS2	Heat Sink	1	For Schottky Diode , 577002	Aavid

TYPICAL APPLICATION

5V to 3.3V for Pentium Application with AGP or Pentium II Application without ATX power supply
Switching mode Operation.

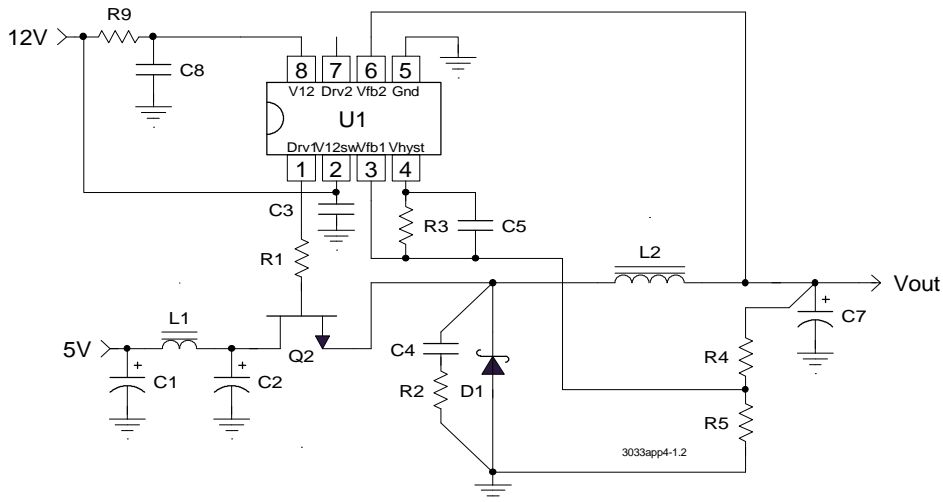

Figure4- The circuit in figure 4 is the application of the US3033 in a switching mode only. This circuit can be used to generate a low cost 5V to 3.3V for either Pentium application with AGP socket or in Pentium II applications where it is desirable to generate an accurate on board 3.3V supply.

Ref Desig	Description	Qty	Part #	Manufacturer
U1	LDO/Switcher IC	1	US3033CS (8 pin SOIC)	Unisem
Q2	MOSFET	1	IRL3303 (TO220) IRL3103S (TO263) (note 1)	International Rectifier
D1	Schottky Diode	1	MBR1045CT (TO220) MBRB1545CT (TO263) (note1)	Motorola
L2	Inductor	1	Core:T50-18,L=4 uH Turns: 10T, 18 AWG	Micro Metal (core)
L1	Inductor	1	L=2 uH	
R1	Resistor	1	22 ohm,5%, SMT 1206 size	
R9	Resistor	1	10 ohm,5%, SMT 0805 size	
R2	Resistor	1	10 ohm, 5%, SMT 1206 size	
R3	Resistor	1	249 kohm,1%, SMT 0805 size	
R4	Resistor	1	1 kohm,1%, SMT 0805 size	
R5	Resistor	1	576 ohm,1%, SMT 0805 size	
C1,2	Capacitor	2	6MV1500GX, 1500uF,6.3V, Elect	Sanyo
C3	Capacitor	1	1 uF,Ceramic, SMT 0805 size	
C4	Capacitor	1	470 pF,Ceramic, SMT 0805 size	Sanyo
C5	Capacitor	1	10 pF,Ceramic, SMT 0805 size	Sanyo
C7	Capacitor	1	6MV1500GX, 1500uF,6.3V, Elect	Sanyo
C8	Capacitor	1	1 uF,Ceramic, SMT 0805 size	
HS1	Heat Sink	1	For MOSFET , 577002	Aavid
HS2	Heat Sink	1	For Schottky Diode , 577002	Aavid

Note 1: For the applications where it is desirable to eliminate the heat sink, the IRL3103S for Q2 and MBR1545CT for D2 in TO263 packages with minimum of 1" square copper pad can be used.

APPLICATION INFORMATION

Introduction

The US3033 device is an application specific product designed to provide an on board dual supply for the new generation of microprocessors requiring separate Core and I/O supplies. One of the processors fitting this requirement is the new Intel P55C™ multimedia microprocessor. Intel specifies a Core voltage of 2.8V nominal ($\pm 100\text{mV}$ max) with maximum Core supply current of 6A while the I/O supply is set for 3.3V with a maximum I/O current of 0.65A. However in most applications the I/O regulator also provides the voltage for other IC functions such as the chip set, Cache,....etc. Typically a low cost solution such as a Low Dropout Linear Regulator (LDO) is selected to provide the I/O supply with the maximum designed current of 3A, keeping the power dissipation and the heat sink to a reasonable size. The Core supply regulator however if also selected to be a linear regulator, will be dissipating a maximum of 12.6W ($(5\text{V}-2.8\text{V})\times 5.7\text{A}$) of power, which requires a substantial amount of heat sinking and perhaps forced air cooling in order to keep it operational. Some manufacturers suggest using two regulators to current share and therefore distribute the power dissipation equally between the regulators. The problem is that, in order to equally current share you need to sense both currents and force the slave regulator to match the master regulator. This can be done, but at the cost of the circuit complexity and much higher system cost and the total power dissipation is still the same. In fact, if the task is to design a flexible motherboard to accommodate the Cyrix 6X86L or their future MMX processors as well, then the power dissipation could easily reach 20W or more. At this power dissipation level the choice for a switching regulator approach becomes evident. However the main reason that designers have always shied away from the switching regulators is their higher price tag and more complex circuit design that is associated with this kind of technique.

The US3033 device is designed to take advantage of the high efficiency of the switching regulator technique for the Core supply while maintaining the low cost LDO regulator for the I/O supply by offering both control functions in a single 8 pin surface mount package. In fact as the typical application circuit shows, one can design a complete flexible motherboard using the US3033 and a few external components yielding a very low component count switching regulator and with an addition of a low cost pass transis-

tor for the I/O supply provide a complete dual supply power solution.

LDO Section

The output voltage of the LDO regulator is externally programmable via 2 external resistors from 1.25V to 5V. The internal voltage reference of the The LDO regulator is set to 1.25V and the output of the regulator can be programmed using the following formula:

$$V_{out} = (1 + R1/R2) \times V_{ref}$$

Where $V_{ref} = 1.25\text{V}$ Typical

R1=Resistor connected from V_{out} to the Vfb2 pin of US3033

R2=Resistor connected from Vfb2 pin to GND.

The US3033 requires the use of an output capacitor as part of the frequency compensation in order to be stable. Typical designs for the microprocessor applications use standard electrolytic capacitors with typical ESR in the range of 50 to 100 m Ω and an output capacitance of 500 to 1000 μF . Fortunately as the capacitance increases, the ESR decreases resulting in a fixed RC time constant. The US3033 takes advantage of this phenomena in making the overall regulator loop stable. For most applications a minimum of 100 μF aluminum electrolytic capacitor such as Sanyo, MVGX series, Panasonic FA series or Nichicon PL series insures both stability and good transient response.

An external filtering is suggested as shown in the application circuit that reduces the switching ripple that might show in the output of the LDO regulator.

Switching Controller Operation

The operation of the switching controller is as follows: after the power is applied, the output drive, "Drv1" goes to 100% duty cycle and the the current in the inductor charges the output capacitor causing the output voltage to increase. When output reaches a pre-programmed set point the feedback pin "Fb1" exceeds 1.25V causing the output drive to switch low and the "Vhyst" pin to switch high which jumps the feedback pin higher than 1.25V resulting in a fixed output ripple which is given by the following equation:

$$\Delta V_o = (R_t/R_h) \times 11$$

Where:

R_t=Top resistor of the output divider, resistor connected from V_{out} to the Vfb1 pin of US3033

R_h=Bottom resistor of the divider, resistor connected from Vfb1 pin to Vhyst pin.

For example, if R_t=1k and R_h=422k, then the output ripple is:

$$\Delta V_o = (1/422) \times 11 = 26\text{mV}$$

The advantage of fixed output ripple is that when the output voltage changes from 2V to 3.5V, the ripple voltage remains the same which is important in meeting the Intel maximum tolerance specification.

Switcher Output Voltage Setting

The output voltage of the switcher can be set using the following equations.

Assuming, $V_o=3.38V$ and the selected output ripple is $\approx 1.3\%$ (44mV) of the output voltage, a set of equations are derived that selects the resistor divider and the hysteresis resistor.

Assuming, $R_t=1k\Omega$, 1%

$$R_h=(11 \cdot R_t)/\Delta V_o$$

Where:

R_t =Top resistor of the resistor divider

R_h =Hysteresis resistor connected between pins 3 and 4 of the US3033

ΔV_o =Selected output ripple (typically 1% to 2% of output voltage)

Assuming, $\Delta V_o=44mV$

$$R_h=(11 \cdot 1000)/0.044=250 k\Omega$$

Select $R_h=249 k\Omega$, 1%

The bottom resistor of the divider is then calculated using the following equations:

$$R_b=R_t/X$$

Where:

R_b =Bottom resistor of the divider

$$X=[(V_o + (\Delta V_o/2))/V_{ref}] - 1$$

$V_{ref}=1.25 V$ typ.

$$X=[(3.38 + (0.044/2))/1.25] - 1 = 1.72$$

$$R_b=1000/1.72=580 \Omega$$

Select $R_b=576 \Omega$, 1%

Frequency Calculation

The US3033 frequency of operation is calculated using the following formula:

$$F_s=[(V_o \cdot (1-D) \cdot ESR)]/(L \cdot \Delta V_o) \text{ (MHz)}$$

Where:

V_o =Output voltage (V)

D =Duty cycle

ESR =Output capacitor ESR (V)

L =Output inductance (uH)

ΔV_o =Output ripple voltage (V)

For our example:

$$D \approx (V_o + V_f)/V_{in}$$

Where, V_f =Forward voltage drop of the Schotky diode

$$D=(3.38 + 0.5)/5=0.78$$

The $ESR=18m\Omega$ for 2 of the Sanyo 1500uF, 6MV1500GX caps. If $L=3.5uH$ then, F_s is calculated as follows:

$$F_s=[(3.38 \cdot (1-0.78) \cdot 0.018)]/(3.5 \cdot 0.044) = 0.087 \text{ Mhz} \\ = 87 \text{ kHz}$$