

14-BITS, 65 MSPS ADC WITH DDR LVDS/CMOS OUTPUTS

Check for Samples: [ADS6142-HT](#)

FEATURES

- **Maximum Sample Rate: 65 MSPS**
- **14-Bit Resolution with No Missing Codes**
- **3.5 dB Coarse Gain and up to 6 dB Programmable Fine Gain for SNR/SFDR Trade-Off**
- **Parallel CMOS and Double Data Rate (DDR) LVDS Output Options**
- **Supports Sine, LVCMOS, LVPECL, LVDS Clock Inputs, and Clock Amplitude Down to 400 mV_{PP}**
- **Clock Duty Cycle Stabilizer**
- **Internal Reference with Support for External Reference**
- **No External Decoupling Required for References**
- **Programmable Output Clock Position and Drive Strength to Ease Data Capture**
- **3.3-V Analog and 1.8-V to 3.3-V Digital Supply**

- **802.16d/e**
- **Test and Measurement Instrumentation**
- **High Definition Video**
- **Medical Imaging**
- **Radar Systems**

SUPPORTS EXTREME TEMPERATURE APPLICATIONS

- **Controlled Baseline**
- **One Assembly/Test Site**
- **One Fabrication Site**
- **Available in Extreme (–40°C/210°C) Temperature Range⁽¹⁾**
- **Extended Product Life Cycle**
- **Extended Product-Change Notification**
- **Product Traceability**
- **Texas Instruments high temperature products utilize highly optimized silicon (die) solutions with design and process enhancements to maximize performance over extended temperatures. All devices are characterized and qualified for 1000 hours of continuous operating life at maximum rated temperature.**

APPLICATIONS

- **Down-Hole Drilling**
- **High Temperature Environment**
- **Wireless Communications Infrastructure**
- **Software Defined Radio**
- **Power Amplifier Linearization**

(1) Custom temperature ranges available

DESCRIPTION

The ADS6142 is a high performance and low power consumption 14-bit A/D converter with a sampling frequency of 65 MSPS. An internal high bandwidth sample and hold and a low jitter clock buffer help to achieve high SNR and high SFDR even at high input frequencies.

The ADS6142 features coarse and fine gain options to improve SFDR performance at lower full-scale analog input ranges.

The digital data outputs are either parallel CMOS or DDR (Double Data Rate) LVDS. Several features exist to ease data capture such as — controls for output clock position and output buffer drive strength, LVDS current, and internal termination programmability.

The output interface type, gain, and other functions are programmed using a 3-wire serial interface. Alternatively, some functions are configured using dedicated parallel pins so the device powers up to the desired state.

The ADS6142 includes internal references while eliminating traditional reference pins and associated external decoupling. External reference mode is also supported.

The ADS6142 is specified over the extreme temperature range (–40°C to 210°C).



Please be aware that an important notice concerning availability, standard warranty, and use in critical applications of Texas Instruments semiconductor products and disclaimers thereto appears at the end of this data sheet.

ADS6142-HT

SLWS234 – DECEMBER 2011

www.ti.com



This integrated circuit can be damaged by ESD. Texas Instruments recommends that all integrated circuits be handled with appropriate precautions. Failure to observe proper handling and installation procedures can cause damage.

ESD damage can range from subtle performance degradation to complete device failure. Precision integrated circuits may be more susceptible to damage because very small parametric changes could cause the device not to meet its published specifications.

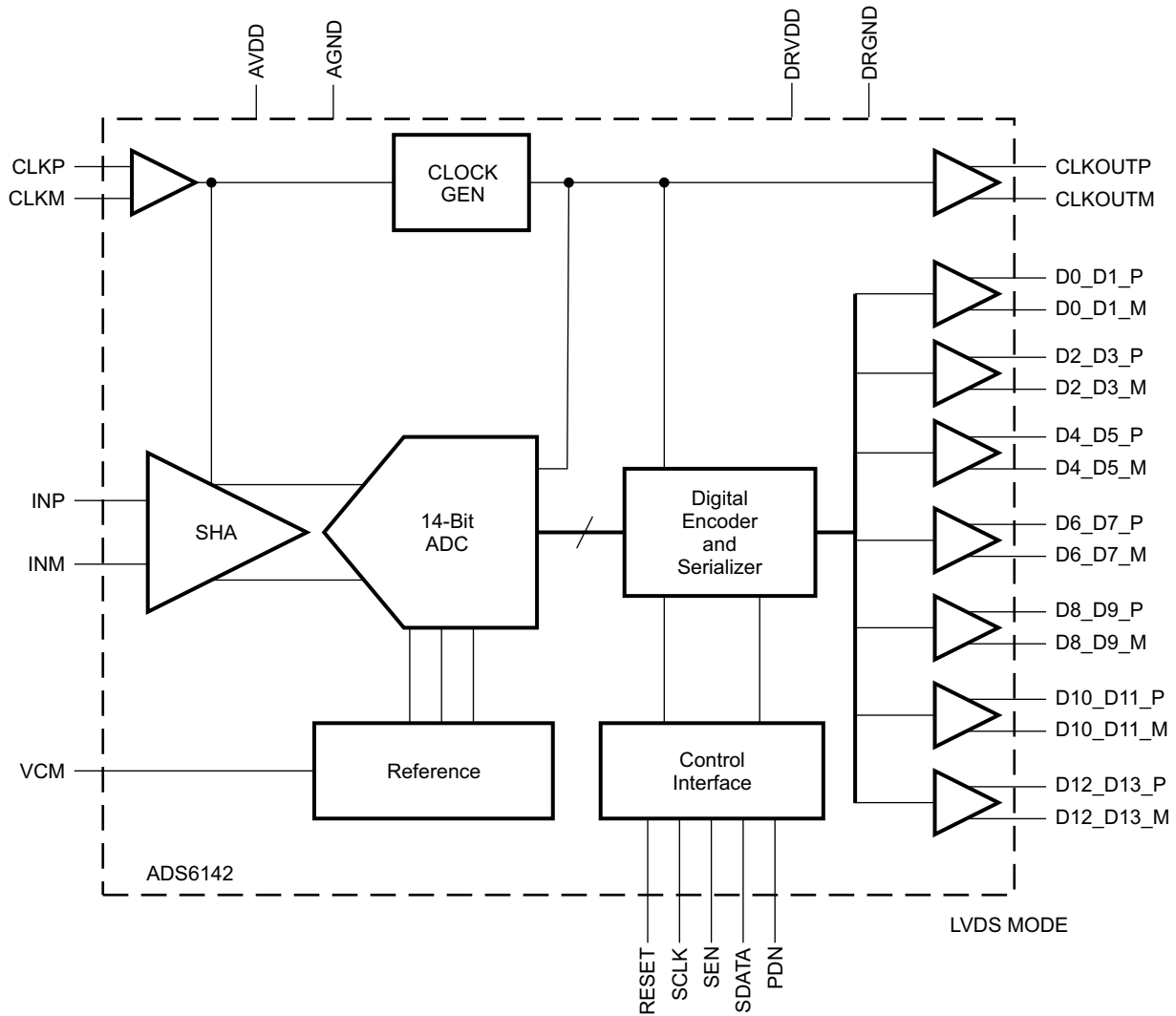

Table 1. ORDERING INFORMATION⁽¹⁾

TA	PACKAGE ⁽²⁾	ORDERABLE PART NUMBER	TOP-SIDE MARKING
-40°C to 210°C	KGD (bare die)	ADS6142SKGD1	NA

(1) For the most current package and ordering information, see the Package Option Addendum at the end of this document, or see the TI Web site at www.ti.com.

(2) Package drawings, standard packing quantities, thermal data, symbolization, and PCB design guidelines are available at www.ti.com/sc/package.

BARE DIE INFORMATION

DIE SIZE	DIE PAD SIZE	DIE PAD COORDINATES	DIE THICKNESS	BACKSIDE FINISH	BACKSIDE POTENTIAL	BOND PAD METALLIZATION COMPOSITION	BOND PAD THICKNESS
2715 x 2460 μm 96.85 x 106.89 mils	70 x 70 μm	See Table 2	11 mils	Silicon with backgrind	DRVSS	Ti/AI-Cu/TiN	1100 nm

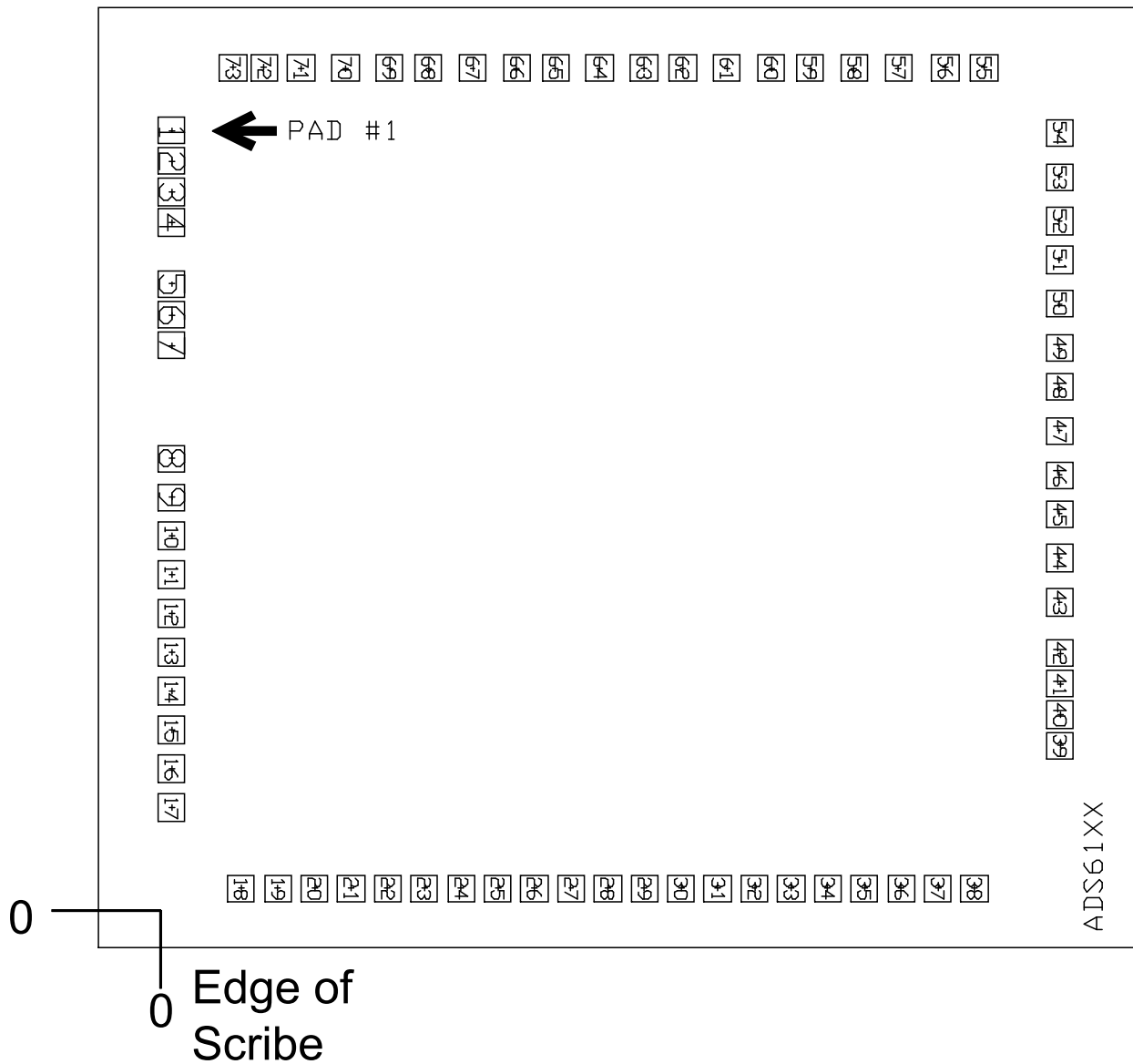

Table 2. BOND PAD COORDINATES

DESCRIPTION	PAD NUMBER	X MIN	Y MIN	X MAX	Y MAX
DRVDD	1	80.92	2065	150.92	2135
N/C	2	80.92	1984.5	150.92	2054.5
N/C	3	80.92	1904	150.92	1974
RESET	4	80.92	1823.5	150.92	1893.5
SCLK	5	80.92	1662.5	150.92	1732.5
SDATA	6	80.92	1582	150.92	1652
SEN	7	80.92	1501.5	150.92	1571.5
N/C	8	80.92	1206.1	150.92	1276.1
N/C	9	80.92	1104.6	150.92	1174.6
AGND	10	80.92	1003.1	150.92	1073.1
AGND	11	80.92	901.6	150.92	971.6
AGND	12	80.92	800.1	150.92	870.1
CLKP	13	80.92	698.6	150.92	768.6
CLKP	14	80.92	597.1	150.92	667.1
CLKM	15	80.92	495.6	150.92	565.6
CLKM	16	80.92	394.1	150.92	464.1
N/C	17	80.92	292.6	150.92	362.6
N/C	18	262.5	80.92	332.5	150.92
AGND	19	358.365	80.92	428.365	150.92
AGND	20	454.23	80.92	524.23	150.92
N/C	21	550.095	80.92	620.095	150.92
INP	22	645.96	80.92	715.96	150.92
INP	23	741.825	80.92	811.825	150.92
INM	24	837.69	80.92	907.69	150.92
INM	25	933.555	80.92	1003.555	150.92
N/C	26	1029.42	80.92	1099.42	150.92
AGND	27	1125.285	80.92	1195.285	150.92
AGND	28	1221.15	80.92	1291.15	150.92
N/C	29	1317.015	80.92	1387.015	150.92
AVDD	30	1412.88	80.92	1482.88	150.92
AVDD	31	1508.745	80.92	1578.745	150.92
VCM	32	1604.61	80.92	1674.61	150.92
VCM	33	1700.475	80.92	1770.475	150.92
N/C	34	1796.34	80.92	1866.34	150.92
N/C	35	1892.205	80.92	1962.205	150.92
N/C	36	1988.07	80.92	2058.07	150.92
AVDD	37	2083.935	80.92	2153.935	150.92
PDN	38	2179.8	80.92	2249.8	150.92
N/C	39	2404.08	455	2474.08	525
N/C	40	2404.08	535.5	2474.08	605.5
N/C	41	2404.08	616	2474.08	686
N/C	42	2404.08	696.5	2474.08	766.5
D0	43	2402.925	829.71	2472.925	899.71
N/C	44	2402.925	945.28	2472.925	1015.28
D1	45	2402.925	1060.85	2472.925	1130.85
D2	46	2402.925	1162.21	2472.925	1232.21
SUBST	47	2402.925	1277.78	2472.925	1347.78

Table 2. BOND PAD COORDINATES (continued)

DESCRIPTION	PAD NUMBER	X MIN	Y MIN	X MAX	Y MAX
D3	48	2402.925	1393.35	2472.925	1463.35
D4	49	2402.925	1494.71	2472.925	1564.71
SUBST	50	2402.925	1610.28	2472.925	1680.28
D5	51	2402.925	1725.85	2472.925	1795.85
D6	52	2402.925	1827.21	2472.925	1897.21
N/C	53	2402.925	1942.78	2472.925	2012.78
D7	54	2402.925	2058.35	2472.925	2128.35
SUBST	55	2205	2229.08	2275	2299.08
SUBST	56	2103.5	2229.08	2173.5	2299.08
OVR	57	1980.79	2227.925	2050.79	2297.925
SUBST	58	1865.22	2227.925	1935.22	2297.925
CLKOUT	59	1749.65	2227.925	1819.65	2297.925
N/C	60	1648.29	2227.925	1718.29	2297.925
SUBST	61	1532.72	2227.925	1602.72	2297.925
N/C	62	1417.15	2227.925	1487.15	2297.925
D8	63	1315.79	2227.925	1385.79	2297.925
SUBST	64	1200.22	2227.925	1270.22	2297.925
D9	65	1084.65	2227.925	1154.65	2297.925
D10	66	983.29	2227.925	1053.29	2297.925
SUBST	67	867.72	2227.925	937.72	2297.925
D11	68	752.15	2227.925	822.15	2297.925
D12	69	650.79	2227.925	720.79	2297.925
SUBST	70	535.22	2227.925	605.22	2297.925
D13	71	419.65	2227.925	489.65	2297.925
SUBST	72	322	2229.08	392	2299.08
DRVDD	73	241.5	2229.08	311.5	2299.08
Substrate should be connected to DRVSS					

ADS6142-HT

SLWS234 – DECEMBER 2011

www.ti.com

ABSOLUTE MAXIMUM RATINGS⁽¹⁾

		VALUE	UNIT
V _I	Supply voltage range, AVDD	-0.3 to 3.9	V
	Supply voltage range, DRVDD	-0.3 to 3.9	V
	Voltage between AGND and DRGND	-0.3 to 0.3	V
	Voltage between AVDD to DRVDD	-0.3 to 3.3	V
	Voltage applied to VCM pin (in external reference mode)	-0.3 to 2	V
	Voltage applied to analog input pins, INP and INM	-0.3 to minimum (3.6, AVDD + 0.3)	V
	Voltage applied to analog input pins, CLKP and CLKM	-0.3 to (AVDD + 0.3)	V
T _J	Operating junction temperature range	-40 to 210	°C
T _{stg}	Storage temperature range	-65 to 210	°C

- (1) Stresses beyond those listed under *absolute maximum ratings* may cause permanent damage to the device. These are stress ratings only, and functional operation of the device at these or any other conditions beyond those indicated under *recommended operating conditions* is not implied. Exposure to absolute-maximum-rated conditions for extended periods may affect device reliability.

RECOMMENDED OPERATING CONDITIONS

over operating free-air temperature range (unless otherwise noted)

		$T_J = -40^{\circ}\text{C to } 125^{\circ}\text{C}$			$T_J = 210^{\circ}\text{C}$			UNIT	
		MIN	NOM	MAX	MIN	NOM	MAX		
SUPPLIES									
AVDD	Analog supply voltage	3	3.3	3.6	3	3.3	3.6	V	
DRVDD	Output buffer supply voltage	CMOS Interface	1.65	1.8 to 3.3	3.6	1.65	1.8 to 3.3	3.6	V
		LVDS Interface	3	3.3	3.6	3	3.3	3.6	V
ANALOG INPUTS									
	Differential input voltage range	2			2			V_{pp}	
V_{IC}	Input common-mode voltage	1.5 ± 0.1			1.5 ± 0.1			V	
	Voltage applied on VCM in external reference mode	1.45	1.5	1.55	1.45	1.5	1.55	V	
CLOCK INPUT									
	Input clock sample rate, F_S	1		65	1		65	MSPS	
Input clock amplitude differential ($V_{CLKP} - V_{CLKM}$)	Sine wave, ac-coupled	0.4	1.5		0.4	1.5		V_{pp}	
	LVPECL, ac-coupled		± 0.8			± 0.8			
	LVDS, ac-coupled		± 0.35			± 0.35			
	LVC MOS, ac-coupled		3.3			3.3			
	Input Clock duty cycle	35%	50%	65%	35%	50%	65%		
DIGITAL OUTPUTS									
Output buffer drive strength ⁽¹⁾	For $C_{LOAD} \leq 5$ pF and $DRVDD \geq 2.2$ V	DEFAULT strength			DEFAULT strength				
	For $C_{LOAD} > 5$ pF and $DRVDD \geq 2.2$ V	MAXIMUM strength			MAXIMUM strength				
	For $DRVDD < 2.2$ V	MAXIMUM strength			MAXIMUM strength				
C_{LOAD}	Maximum external load capacitance from each output pin to DRGND	CMOS Interface, maximum buffer strength	10		10		pF		
		LVDS Interface, without internal termination	5		5				
		LVDS Interface, with internal termination	10		10				
R_{LOAD}	Differential load resistance (external) between the LVDS output pairs	100			100			Ω	
T_J	Operating junction temperature range	-40		125			210	$^{\circ}\text{C}$	

(1) See [Output Buffer Strength Programmability](#) in the application section.

ADS6142-HT

SLWS234 – DECEMBER 2011

www.ti.com

ELECTRICAL CHARACTERISTICS

Typical values are at 25°C, AVDD = DRVDD = 3.3 V, maximum rated sampling frequency, 50% clock duty cycle, –1 dBFS differential analog input, internal reference mode, applies to CMOS and LVDS interfaces, unless otherwise noted.

PARAMETER	T _J = -40°C to 125°C			T _J = 210°C			UNIT
	MIN	TYP	MAX	MIN	TYP	MAX	
RESOLUTION		14			14		Bits
ANALOG INPUT							
Differential input voltage range		2			2		V _{PP}
Differential input resistance (dc), see Figure 37		> 1			> 1		MΩ
Differential input capacitance, see Figure 38		7			7		pF
Analog input bandwidth		450			300		MHz
Analog input common-mode current (per input pin of each ADC)		92			95		μA
REFERENCE VOLTAGES							
VREFB Internal reference bottom voltage		1			1		V
VREFT Internal reference top voltage		2			2		V
ΔV _{REF} Internal reference error (VREFT–VREFB)	-30	±5	30	-55	±5	55	mV
V _{CM} Common-mode output voltage		1.5			1.5		V
V _{CM} Output current capability		4			4		mA
DC ACCURACY							
No missing codes	Specified			Specified			
E _O Offset error	-11	±2	11	-13	±10	13	mV
Offset error temperature coefficient		0.04			0.06		mV/°C
There are two sources of gain error – internal reference inaccuracy and channel gain error							
E _{GREF} Gain error due to internal reference inaccuracy alone, (ΔV _{REF} / 2) %	-1	0.6	1	-1	0.65	1	% FS
E _{GCHAN} Gain error of channel alone ⁽¹⁾		±0.3			±0.3		% FS
Channel gain error temperature coefficient		0.005					Δ%/°C
DNL Differential nonlinearity	-0.95	0.5	2	-0.99	±0.5	2.5	LSB
INL Integral nonlinearity	-10	±2	10	-18	±6	18	LSB
POWER SUPPLY							
I _{AVDD} Analog supply current		0.75			0.76		mA
I _{DRVDD} Digital supply current, CMOS interface, DRVDD = 1.8 V, No load capacitance, F _{in} = 2 MHz ⁽²⁾		4			4		mA
I _{DRVDD} Digital supply current, LVDS interface, DRVDD = 3.3 V, with 100-Ω external termination		21			48		mA
Total power, CMOS, DRVDD = 3.3 V ⁽³⁾		418	450		422	500	mW
Global power down		30	60		30	70	mW

(1) Specified by design and characterization; not tested in production.

(2) In CMOS mode, the DRVDD current scales with the sampling frequency and the load capacitance on the output pins (see Figure 30).

(3) The maximum DRVDD current depends on the actual load capacitance on the digital output lines. Note that the maximum recommended load capacitance is 10 pF.

ELECTRICAL CHARACTERISTICS

Typical values are at 25°C, AVDD = DRVDD = 3.3 V, maximum rated sampling frequency, 50% clock duty cycle, –1 dBFS differential analog input, internal reference mode, applies to CMOS and LVDS interfaces, unless otherwise noted.

PARAMETER	TEST CONDITIONS	T _J = -40°C to 125°C			T _J = 210°C			UNIT	
		MIN	TYP	MAX	MIN	TYP	MAX		
DYNAMIC AC CHARACTERISTICS									
SNR Signal-to-noise ratio, CMOS	F _{in} = 10 MHz			74.7				dBFS	
	F _{in} = 50 MHz			74.4					
	F _{in} = 70 MHz			61.5	74.4	57.5	74		
	F _{in} = 170 MHz	0 dB Gain			72.7				
		3.5 dB Coarse gain			71.8				
	F _{in} = 230 MHz	0 dB Gain			71.7	65.5			
3.5 dB Coarse gain				70.9	63				
SNR Signal-to-noise ratio, LVDS	F _{in} = 10 MHz			75				dBFS	
	F _{in} = 50 MHz			74.6					
	F _{in} = 70 MHz			68	74.6	62	75		
	F _{in} = 170 MHz	0 dB Gain			72.9				
		3.5 dB Coarse gain			72.1				
	F _{in} = 230 MHz	0 dB Gain			72	60			
3.5 dB Coarse gain				71.2					
RMS output noise	Inputs tied to common-mode		1.05					LSB	
SINAD Signal-to-noise and distortion ratio CMOS	F _{in} = 10 MHz			74.6				dBFS	
	F _{in} = 50 MHz			74.1					
	F _{in} = 70 MHz			60.5	74.0	56.5	74		
	F _{in} = 170 MHz	0 dB Gain			72.2				
		3.5 dB Coarse gain			71.5				
	F _{in} = 230 MHz	0 dB Gain			70.6	56			
3.5 dB Coarse gain				70.4	57				
SINAD Signal-to-noise and distortion ratio LVDS	F _{in} = 10 MHz			74.9				dBFS	
	F _{in} = 50 MHz			74.4					
	F _{in} = 70 MHz			67	74.4	64	74		
	F _{in} = 170 MHz	0 dB Gain			72.4				
		3.5 dB Coarse gain			71.9				
	F _{in} = 230 MHz	0 dB Gain			70.5	56			
3.5 dB Coarse gain				70.5					
ENOB Effective number of bits	F _{in} = 50 MHz							Bits	
	F _{in} = 70 MHz			10.5	12	9.4	12		
SFDR Spurious free dynamic range	F _{in} = 10 MHz			95				dBc	
	F _{in} = 50 MHz			89					
	F _{in} = 70 MHz			70	78	66	77		
	F _{in} = 170 MHz	0 dB Gain			82				
		3.5 dB Coarse gain			84				
	F _{in} = 230 MHz	0 dB Gain			79				58
3.5 dB Coarse gain				82			60		
THD Total harmonic distortion	F _{in} = 10 MHz			93				dBc	
	F _{in} = 50 MHz			88					
	F _{in} = 70 MHz			72	85	66	75		
	F _{in} = 170 MHz	0 dB Gain			80				
		3.5 dB Coarse gain			82				
	F _{in} = 230 MHz	0 dB Gain			76				56
3.5 dB Coarse gain				78.5			59		

ADS6142-HT

SLWS234 – DECEMBER 2011

www.ti.com

ELECTRICAL CHARACTERISTICS (continued)

Typical values are at 25°C, AVDD = DRVDD = 3.3 V, maximum rated sampling frequency, 50% clock duty cycle, –1 dBFS differential analog input, internal reference mode, applies to CMOS and LVDS interfaces, unless otherwise noted.

PARAMETER	TEST CONDITIONS	T _J = -40°C to 125°C			T _J = 210°C			UNIT	
		MIN	TYP	MAX	MIN	TYP	MAX		
HD2 Second harmonic distortion	F _{in} = 10 MHz		98					dBc	
	F _{in} = 50 MHz		96						
	F _{in} = 70 MHz		73	93	66	76			
	F _{in} = 170 MHz	0 dB Gain		86					
		3.5 dB Coarse gain		87					
	F _{in} = 230 MHz	0 dB Gain		79			58		
3.5 dB Coarse gain			81			60			
HD3 Third harmonic distortion	F _{in} = 10 MHz		95					dBc	
	F _{in} = 50 MHz		89						
	F _{in} = 70 MHz		75	86	70	84			
	F _{in} = 170 MHz	0 dB Gain		82					
		3.5 dB Coarse gain		84					
	F _{in} = 230 MHz	0 dB Gain		79			75		
3.5 dB Coarse gain			82			74			
Worst spur (other than HD2, HD3)	F _{in} = 10 MHz		97					dBc	
	F _{in} = 50 MHz		96						
	F _{in} = 70 MHz		95						
	F _{in} = 170 MHz		91						
	F _{in} = 230 MHz		90						
IMD 2-Tone intermodulation distortion	F1 = 185 MHz, F2 = 190 MHz, Each tone at -7 dBFS		91			90		dBFS	
Input overload recovery	Recovery to within 3% (of final value) for 6-dB overload with sine wave input		1			1		clock cycles	
PSRR AC Power supply rejection ratio	For 100 mVpp signal on AVDD supply		49			48		dBc	

DIGITAL CHARACTERISTICS

The dc specifications refer to the condition where the digital outputs are not switching, but are permanently at a valid logic level 0 or 1, AVDD = 3.3 V

PARAMETER	TEST CONDITIONS	T _J = -40°C to 125°C			T _J = 210°C			UNIT
		MIN	TYP	MAX	MIN	TYP	MAX	
DIGITAL INPUTS								
PDN, SCLK, SDATA, and SEN ⁽¹⁾								
High-level input voltage		2.4			2.4			V
Low-level input voltage					0.8			V
High-level input current		33			33			μA
Low-level input current		-33			-33			μA
Input capacitance		4			4			pF
DIGITAL OUTPUTS								
CMOS INTERFACE, DRVDD = 1.8 to 3.3 V								
High-level output voltage		DRVDD			DRVDD			V
Low-level output voltage		0			0			V
Output capacitance	Output capacitance inside the device, from each output to ground	2			2			pF
DIGITAL OUTPUTS								
LVDS INTERFACE, DRVDD = 3.3 V, I_O = 3.5 mA, R_L = 100 Ω ⁽²⁾								
High-level output voltage		1375			1375			mV
Low-level output voltage		1025			1025			mV
V _{od}	Output differential voltage	225	350		225	350		mV
V _{os}	Output offset voltage, single-ended	Common-mode voltage of OUTP, OUTM			1200			mV
Output capacitance	Output capacitance inside the device, from either output to ground	2			2			pF

- (1) SCLK and SEN function as digital input pins when they are used for serial interface programming. When used as parallel control pins, analog voltage needs to be applied as per [Table 3](#) & [Table 4](#)
- (2) I_O Refers to the LVDS buffer current setting, R_L is the differential load resistance between the LVDS output pair.

ADS6142-HT

SLWS234 – DECEMBER 2011

www.ti.com

TIMING CHARACTERISTICS – LVDS AND CMOS MODES⁽¹⁾

Typical values are at 25°C, min and max values are across the full temperature range $T_{MIN} = -40^{\circ}C$ to $T_{MAX} = 125^{\circ}C$ or $210^{\circ}C$ as indicated, AVDD = DRVDD = 3.3 V, maximum rated sampling frequency, sine wave input clock, 1.5 V_{PP} clock amplitude, C_L = 5 pF⁽²⁾, I_O = 3.5 mA, R_L = 100 Ω⁽³⁾, no internal termination, unless otherwise noted.

For timings at lower sampling frequencies, see section [Output Timings](#) in the APPLICATION INFORMATION of this data sheet.

PARAMETER	TEST CONDITIONS	T _J = -40°C to 125°C			T _J = 210°C			UNIT
		MIN	TYP	MAX	MIN	TYP	MAX	
t _a	Aperture delay		1.5					ns
t _j	Aperture jitter		150					fs rms
Wake-up time (to valid data)	From global power down		15					μs
	From standby		15					μs
	From output buffer disable	CMOS	100					ns
		LVDS	200					ns
Latency			9					clock cycles
DDR LVDS MODE⁽⁴⁾, DRVDD = 3.3 V								
t _{su}	Data setup time ⁽⁵⁾	Data valid ⁽⁶⁾ to zero-cross of CLKOUTP	5.8		5.6			ns
t _h	Data hold time ⁽⁵⁾	Zero-cross of CLKOUTP to data becoming invalid ⁽⁶⁾	1.3		1.5			ns
t _{PDI}	Clock propagation delay	Input clock rising edge zero-cross to output clock rising edge zero-cross	6.2		7.2			ns
	LVDS bit clock duty cycle	Duty cycle of differential clock, (CLKOUTP-CLKOUTM), 10 ≤ F _s ≤ 125 MSPS	46%		46%			
t _r t _f	Data rise time, Data fall time	Rise time measured from -50 mV to 50 mV, Fall time measured from 50 mV to -50 mV, 1 ≤ F _s ≤ 125 MSPS	112		116			ps
t _{CLKRISE} t _{CLKFALL}	Output clock rise time, Output clock fall time	Rise time measured from -50 mV to 50 mV, Fall time measured from 50 mV to -50 mV, 1 ≤ F _s ≤ 125 MSPS	112		116			ps
PARALLEL CMOS MODE, DRVDD = 2.5 V to 3.3 V, default output buffer drive strength⁽⁷⁾								
t _{su}	Data setup time ⁽⁵⁾	Data valid ⁽⁸⁾ to 50% of CLKOUT rising edge	8		9			ns
t _h	Data hold time ⁽⁵⁾	50% of CLKOUT rising edge to data becoming invalid ⁽⁸⁾	6.5		6.8			ns
t _{PDI}	Clock propagation delay	Input clock rising edge zero-cross to 50% of CLKOUT rising edge	7.3		8.3			ns
	Output clock duty cycle	Duty cycle of output clock (CLKOUT), 10 ≤ F _s ≤ 125 MSPS	42%		42%			
t _r t _f	Data rise time, Data fall time	Rise time measured from 20% to 80% of DRVDD, Fall time measured from 80% to 20% of DRVDD, 1 ≤ F _s ≤ 125 MSPS	1.9		2.1			ns
t _{CLKRISE} t _{CLKFALL}	Output clock rise time, Output clock fall time	Rise time measured from 20% to 80% of DRVDD, Fall time measured from 80% to 20% of DRVDD, 1 ≤ F _s ≤ 125 MSPS	1.9		2.1			ns

- (1) Timing parameters are specified by design and not tested in production.
- (2) C_L is the Effective external single-ended load capacitance between each output pin and ground.
- (3) I_O Refers to the LVDS buffer current setting; R_L is the differential load resistance between the LVDS output pair.
- (4) Measurements are done with a transmission line of 100 Ω characteristic impedance between the device and the load.
- (5) Setup and hold time specifications take into account the effect of jitter on the output data and clock.
- (6) Data valid refers to a logic high of +100 mV and logic low of -100 mV.
- (7) For DRVDD < 2.2 V, it is recommended to use an external clock for data capture and NOT the device output clock signal (CLKOUT). See [Parallel CMOS interface](#) in the application section.
- (8) Data valid refers to a logic high of 2 V (1.7 V) and logic low of 0.8 V (0.7 V) for DRVDD = 3.3 V (2.5 V).

ADD6142-HT Operating Life Derating Chart

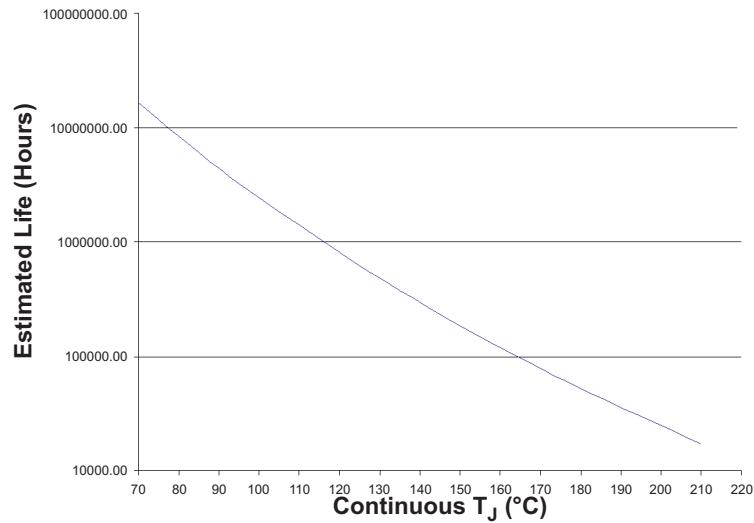

- (1) See data sheet for absolute maximum and minimum recommended operating conditions.
- (2) Silicon operating life design goal is 10 years at 105°C junction temperature (does not include package interconnect life).
- (3) The predicted operating lifetime vs. junction temperature is based on reliability modeling using electromigration as the dominant failure mechanism affecting device wearout for the specific device process and design characteristics.

Figure 1. ADS6142-HT Operating Life Derating Chart

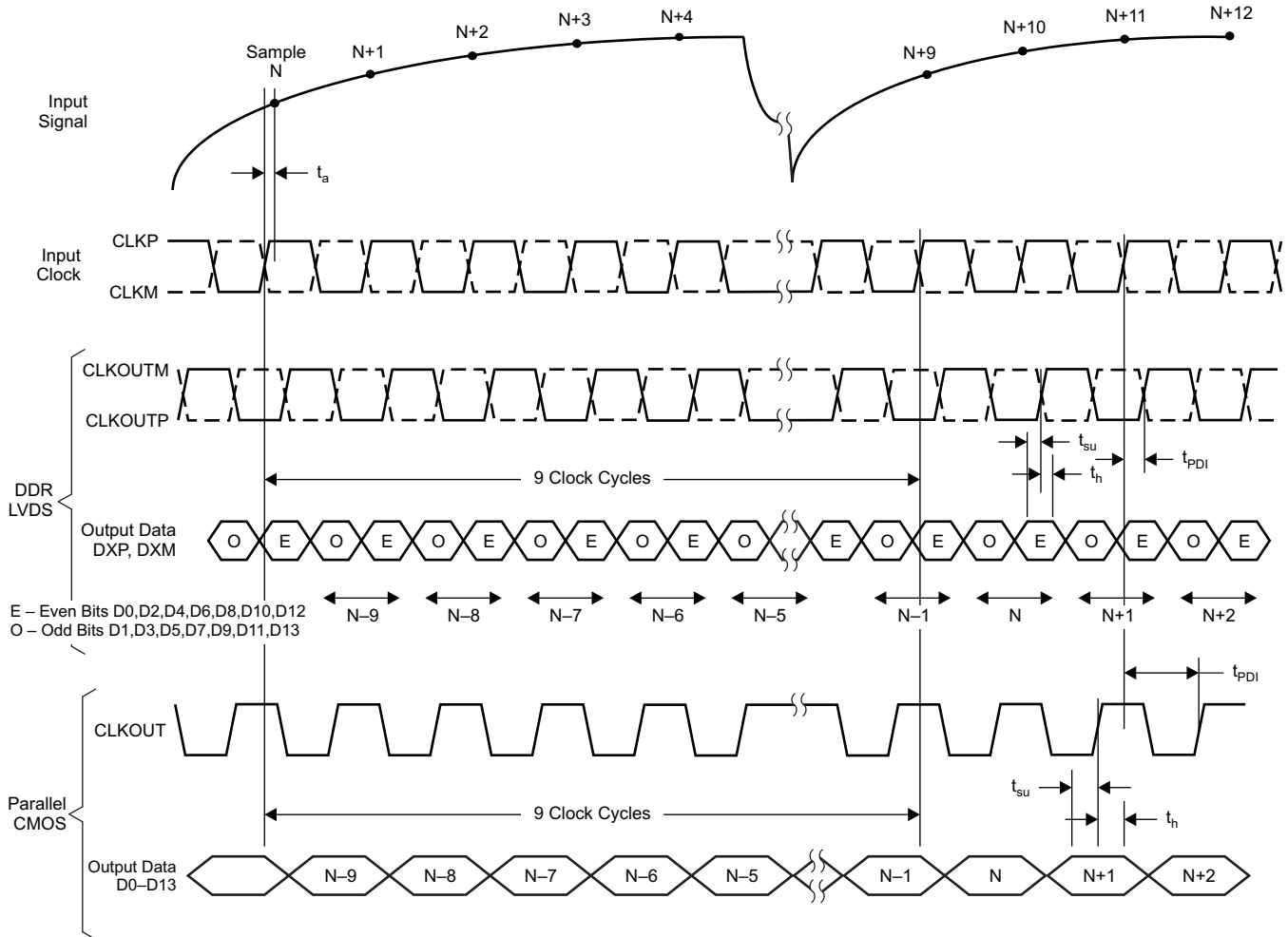
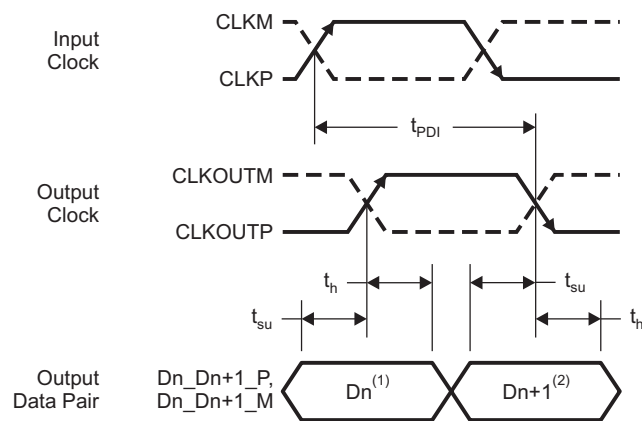

Figure 2. Latency



⁽¹⁾ D_n – Bits D0, D2, D4, D6, D8, D10, D12

⁽²⁾ D_{n+1} – Bits D1, D3, D5, D7, D9, D11, D13

Figure 3. LVDS Mode Timing

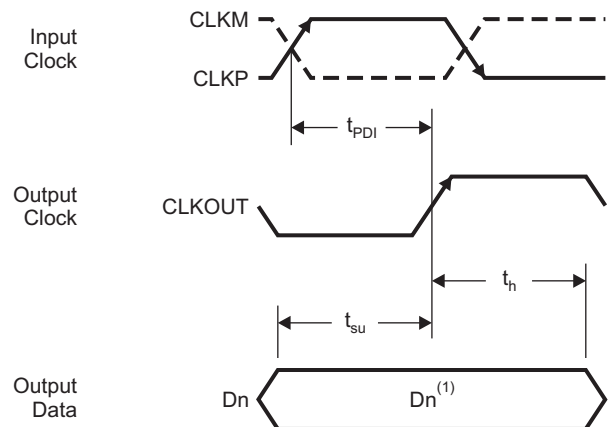

⁽¹⁾ D_n – Bits D0-D13

Figure 4. CMOS Mode Timing

DEVICE PROGRAMMING MODES

The ADS6142 has several features that can be easily configured using either parallel interface control or serial interface programming.

USING SERIAL INTERFACE PROGRAMMING ONLY

To program using the serial interface, the internal registers must first be reset to their default values, and the RESET pin must be kept **low**. In this mode, SEN, SDATA, and SCLK function as serial interface pins and are used to access the internal registers of the ADC. The registers are reset either by applying a pulse on the RESET pin or by a **high** setting on the <RST> bit (D4 in register 0x00). The [Serial Interface](#) section describes register programming and register reset in more detail.

USING PARALLEL INTERFACE CONTROL ONLY

To control the device using the parallel interface, keep RESET tied **high** (AVDD). Now SEN, SCLK, SDATA, and PDN function as parallel interface control pins. These pins can be used to directly control certain modes of the ADC by connecting them to the correct voltage levels (as described in [Table 3](#) to [Table 5](#)). There is no need to apply a reset pulse.

Frequently used functions are controlled in this mode — standby, selection between LVDS/CMOS output format, internal/external reference, and 2s complement/straight binary output format.

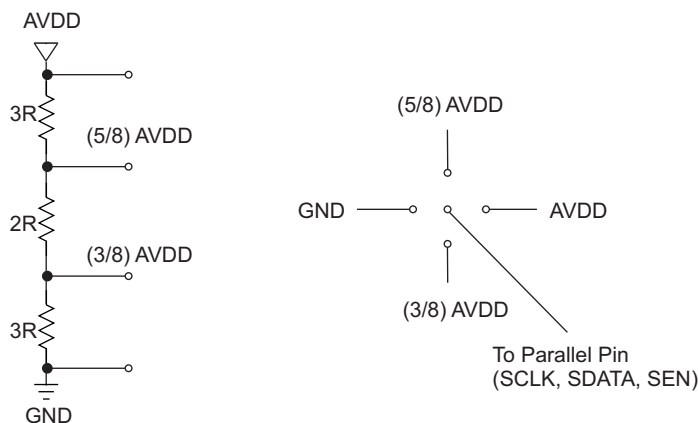

Figure 5. Simple Scheme to Configure Parallel Pins

DESCRIPTION OF PARALLEL PINS

Table 3. SCLK (Analog Control Pin)

SCLK	DESCRIPTION
0	Internal reference and 0 dB gain (full-scale = 2 V _{PP})
(3/8) AVDD	External reference and 0 dB gain (full-scale = 2 V _{PP})
(5/8) AVDD	External reference and 3.5 dB coarse gain (full-scale = 1.34 V _{PP})
AVDD	Internal reference and 3.5 dB coarse gain (full-scale = 1.34 V _{PP})

Table 4. SEN (Analog Control Pin)

SEN	DESCRIPTION
0	2s Complement format and DDR LVDS interface
(3/8) AVDD	Straight binary format and DDR LVDS interface
(5/8) AVDD	Straight binary and parallel CMOS interface
AVDD	2s Complement format and parallel CMOS interface

Table 5. SDATA, PDN (Digital Control Pins)

SDATA	PDN	DESCRIPTION
Low	Low	Normal operation
Low	High (AVDD)	Standby - only the ADC is powered down
High (AVDD)	Low	Output buffers are powered down, fast wake-up time
High (AVDD)	High (AVDD)	Global power down. ADC, internal reference, and output buffers are powered down, slow wake-up time

SERIAL INTERFACE

The ADC has a set of internal registers, which can be accessed through the serial interface formed by pins SEN (Serial interface Enable), SCLK (Serial Interface Clock), SDATA (Serial Interface Data) and RESET. After device power-up, the internal registers must be reset to their default values by applying a high-going pulse on RESET (of width greater than 10 ns).

Serial shift of bits into the device is enabled when SEN is low. Serial data SDATA is latched at every falling edge of SCLK when SEN is active (low). The serial data is loaded into the register at every 16th SCLK falling edge when SEN is low. If the word length exceeds a multiple of 16 bits, the excess bits are ignored. Data is loaded in multiples of 16-bit words within a single active SEN pulse.

The first 5 bits form the register address and the remaining 11 bits form the register data.

The interface can work with a SCLK frequency from 20 MHz down to very low speeds (a few hertz) and also with a non-50% SCLK duty cycle.

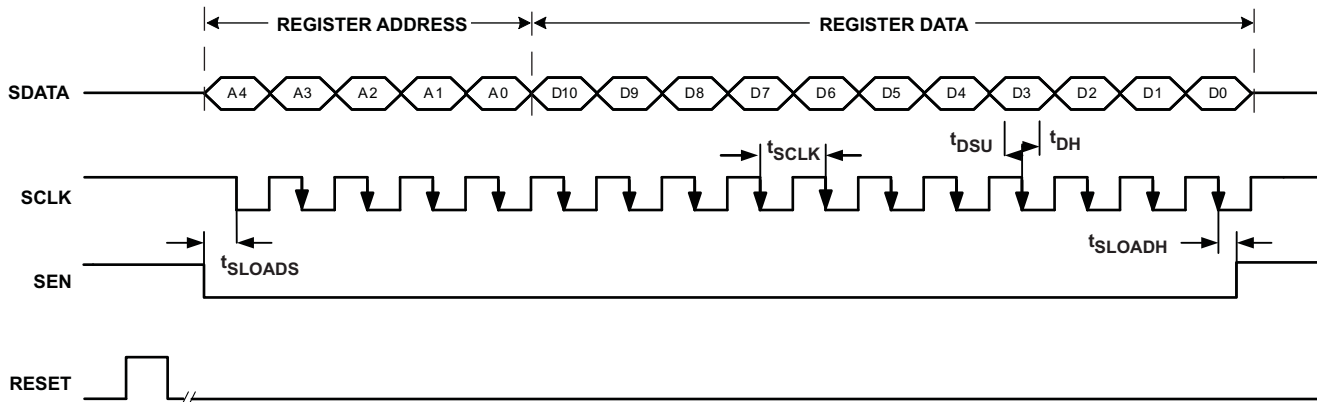

Figure 6. Serial Interface Timing Diagram

REGISTER INITIALIZATION

After power-up, the internal registers *must* be reset to their default values. This is done in one of two ways:

1. Either through a hardware reset by applying a high-going pulse on the RESET pin (width greater than 10 ns) as shown in [Figure 6](#).

OR

2. By applying a software reset. Using the serial interface, set the <RST> bit (D4 in register 0x00) to **high**. This initializes the internal registers to their default values and then self-resets the <RST> bit to **low**. In this case the RESET pin is kept **low**.

SERIAL INTERFACE TIMING

Typical values at 25°C, min and max values across the full temperature range $T_{MIN} = -40^{\circ}C$ to $T_{MAX} = 210^{\circ}C$, AVDD = DRVDD = 3.3 V (unless otherwise noted)

		MIN	TYP	MAX	UNIT
f_{SCLK}	SCLK Frequency = $1/t_{SCLK}$	> DC		20	MHz
t_{SLOADS}	SEN to SCLK Setup time	25			ns
t_{SLOADH}	SCLK to SEN Hold time	25			ns
t_{DSU}	SDATA Setup time	25			ns
t_{DH}	SDATA Hold time	25			ns

RESET TIMING

Typical values at 25°C, min and max values across the full temperature range $T_{MIN} = -40^{\circ}C$ to $T_{MAX} = 85^{\circ}C$, AVDD = DRVDD = 3.3 V (unless otherwise noted)

PARAMETER	TEST CONDITIONS	MIN	TYP	MAX	UNIT
t_1	Power-on delay	5			ms
t_2	Reset pulse width	10			ns
t_3	Register write delay	25			ns
t_{PO}	Power-up time		6.5		ms

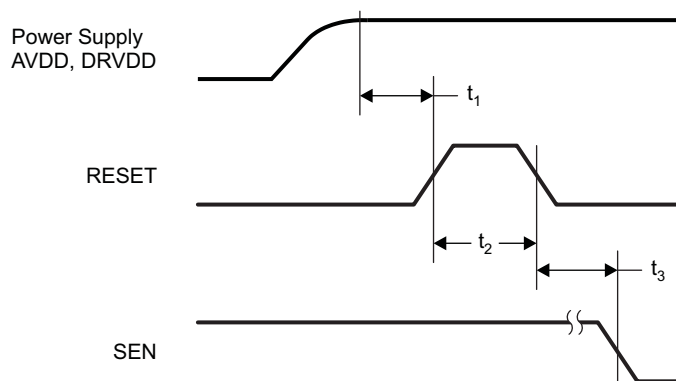

NOTE: A high-going pulse on the RESET pin is required in serial interface mode in the case of initialization through a hardware reset. For parallel interface operation, RESET has to be tied permanently HIGH.

Figure 7. Reset Timing Diagram

ADS6142-HT

SLWS234 – DECEMBER 2011

www.ti.com

SERIAL REGISTER MAP

Table 6 gives a summary of all the modes that can be programmed through the serial interface.

Table 6. Summary of Functions Supported by Serial Interface^{(1) (2)}

REGISTER ADDRESS IN HEX	REGISTER FUNCTIONS											
	A4 - A0	D10	D9	D8	D7	D6	D5	D4	D3	D2	D1	D0
00	<PDN OBUF> Output buffers powered down	<COARSE GAIN> Coarse gain	<LVDS CMOS> LVDS or CMOS Output interface	0	0	<REF> Internal or external Reference	<RST> Software reset	0	<PDN CLKOUT> Output clock buffer powered down	0	<STBY> ADC Power down	
04	<DATAOUT POSN> Output data position control	<CLKOUT EDGE> Output clock edge control	<CLKOUT POSN> Output clock position control	0	0	0	0	0	0	0	0	
09	Bit-wise or Byte-wise control	0	0	0	0	0	0	0	0	0	0	
0A	<DATA FORMAT> 2s Complement or straight binary	0	0	<TEST PATTERNS>			0	0	0	0	0	
0B	<CUSTOM LOW> Custom pattern lower 9 bits									0	0	
0C	<FINE GAIN> Fine gain 0 to 6dB				0	0	0	<CUSTOM HIGH> Custom pattern upper 5 bits				
0E	0	LVDS Termination LVDS Internal termination control for output data and clock						<LVDS CURRENT> LVDS Current control		<CURRENT DOUBLE> LVDS current double		
0F	0	0	0	<DRIVE STRENGTH> CMOS output buffer drive strength control				0	0	0	0	

(1) The unused bits in each register (shown by blank cells in above table) must be programmed as '0'.

(2) Multiple functions in a register can be programmed in a single write operation.

DESCRIPTION OF SERIAL REGISTERS

Each register function is explained in detail.

Table 7.

A4–A0 (hex)	D10	D9	D8	D7	D6	D5	D4	D3	D2	D1	D0
00	<PDN OBUF> Output buffers powered down	<COARSE GAIN> Coarse gain	<LVDS CMOS> LVDS or CMOS Output interface	0	0	<REF> Internal or external reference	<RST> Software reset	0	<PDN CLKOUT> Output clock buffer powered down	0	<STBY> ADC Power down

D0 <STBY> [Power down modes](#)

- 0 Normal operation
- 1 Device enters standby mode where only ADC is powered down.

D2 <PDN CLKOUT> [Power down modes](#)

- 0 Output clock is active (on CLKOUT pin)
- 1 Output clock buffer is powered down and becomes three-stated. Data outputs are unaffected.

D4 <RST>

- 1 Software reset applied - resets all internal registers and the bit self-clears to 0.

D5 <REF> [Reference selection](#)

- 0 Internal reference enabled
- 1 External reference enabled

D8 <LVDS CMOS> [Output Interface selection](#)

- 0 Parallel CMOS interface
- 1 DDR LVDS Interface

D9 <COARSE GAIN> [Gain programming](#)

- 0 0 dB Coarse gain
- 1 3.5 dB Coarse gain

D10 <PDN OBUF> [Power down modes](#)

- 0 Output data and clock buffers enabled
- 1 Output data and clock buffers disabled

Table 8.

A4–A0 (hex)	D10	D9	D8	D7	D6	D5	D4	D3	D2	D1	D0
04	<DATAOUT POSN> Output data position control	<CLKOUT EDGE> Output Clock edge control	<CLKOUT POSN> Output clock position control	0	0	0	0	0	0	0	0

D8 <CLKOUT POSN> [Output clock position control](#)

- 0 Default output clock position after reset. The setup/hold timings for this clock position are specified in the timing specifications table.
- 1 Output clock shifted (delayed) by 400 ps

D9 <CLKOUT EDGE>

- 0 Use rising edge to capture data
- 1 Use falling edge to capture data

D10 <DATAOUT_POSN>

- 0 Default position (after reset)
- 1 Data transition delayed by half clock cycle with respect to default position

Table 9.

A4–A0 (hex)	D10	D9	D8	D7	D6	D5	D4	D3	D2	D1	D0
09	Bit-wise or Byte-wise control	0	0	0	0	0	0	0	0	0	0

D10 Bit-wise or byte-wise selection (DDR LVDS mode only)

- 0 Bit-wise sequence - Even data bits (D0, D2, D4,..D12) are output at the rising edge of CLKOUTP and odd data bits (D1, D3, D5,..D13) at the falling edge of CLKOUTP
- 1 Byte-wise sequence - Lower 7 data bits (D0-D7) are output at the rising edge of CLKOUTP and upper 7 data bits (D8-D13) at the falling edge of CLKOUTP

Table 10.

A4-A0 (hex)	D10	D9	D8	D7	D6	D5	D4	D3	D2	D1	D0
0A	<DF> 2s Complement or straight binary	0	0	<TEST PATTERNS>			0	0	0	0	0

D7-D5 Test patterns

000	Normal operation - <D13:D0> = ADC output
001	All zeros - <D13:D0> = 0x0000
010	All ones - <D13:D0> = 0x3FFF
011	Toggle pattern - <D13:D0> toggles between 0x2AAA and 0x1555
100	Digital ramp - <D13:D0> increments from 0x0000 to 0x3FFF by one code every cycle
101	Custom pattern - <D13:D0> = contents of CUSTOM PATTERN registers
110	Unused
111	Unused

D10 <DATA FORMAT>

0	2s Complement
1	Straight binary

Table 11.

A4-A0 (hex)	D10	D9	D8	D7	D6	D5	D4	D3	D2	D1	D0
0B	<CUSTOM LOW> Lower 9 bits of custom pattern									0	0

Table 12.

A4-A0 (hex)	D10	D9	D8	D7	D6	D5	D4	D3	D2	D1	D0
0C	<FINE GAIN> Fine gain 0 to 6dB			0	0	0	<CUSTOM HIGH> Upper 5 bits of custom pattern				

Reg 0B <CUSTOM LOW> - Specifies lower 9 bits of custom pattern
D10-D2

Reg 0C <CUSTOM HIGH> - Specifies upper 5 bits of custom pattern
D4-D0

D10-D8 <FINE GAIN> [Gain programming](#)

000	0 dB Gain
001	1 dB Gain
010	2 dB Gain
011	3 dB Gain
100	4 dB Gain
101	5 dB Gain
110	6 dB Gain
111	Unused

Table 13.

A4-A0 (hex)	D10	D9	D8	D7	D6	D5	D4	D3	D2	D1	D0
0E	0	<LVDS TERMINATION> LVDS Internal termination control for output data and clock						<LVDS CURRENT> LVDS Current control		<CURRENT DOUBLE> LVDS Current double	

D1-D0 <CURRENT DOUBLE> [LVDS current programming](#)
D0 LVDS Data buffer current control

- 0 Default current, set by <LVDS_CURR>
- 1 2x LVDS Current set by <LVDS_CURR>

D1 LVDS Clock buffer current control

- 0 Default current, set by <LVDS_CURR>
- 1 2x LVDS Current set by <LVDS_CURR>

D3-D2 <LVDS CURRENT> [LVDS current programming](#)

- 00 3.5 mA
- 01 2.5 mA
- 10 4.5 mA
- 11 1.75 mA

D9-D4 [LVDS internal termination](#)
D9-D7 <DATA TERM> Internal termination for LVDS output data bits

- 000 No internal termination
- 001 300 Ω
- 010 185 Ω
- 011 115 Ω
- 100 150 Ω
- 101 100 Ω
- 110 80 Ω
- 111 65 Ω

D6-D4 <CLKOUT TERM> Internal termination for LVDS output clock

- 000 No internal termination
- 001 300 Ω
- 010 185 Ω
- 011 115 Ω
- 100 150 Ω
- 101 100 Ω
- 110 80 Ω
- 111 65 Ω

Table 14.

A4–A0 (hex)	D10	D9	D8	D7	D6	D5	D4	D3	D2	D1	D0
0F	0	0	0	<DRIVE STRENGTH> CMOS Output buffer drive strength control				0	0	0	0

D7-D4 <DRIVE STRENGTH> [Output buffer drive strength controls](#)

0101	WEAKER than default drive
0000	DEFAULT drive strength
1111	STRONGER than default drive strength (recommended for load capacitances > 5 pF)
1010	MAXIMUM drive strength (recommended for load capacitances > 5 pF)
Other combinations	Do not use

TYPICAL CHARACTERISTICS

All plots are at 25°C, AVDD = DRVDD = 3.3 V, maximum rated sampling frequency, sine wave input clock, 1.5 V_{PP} differential clock amplitude, 50% clock duty cycle, -1 dBFS differential analog input, internal reference mode, 0 dB gain, CMOS output interface (unless otherwise noted)

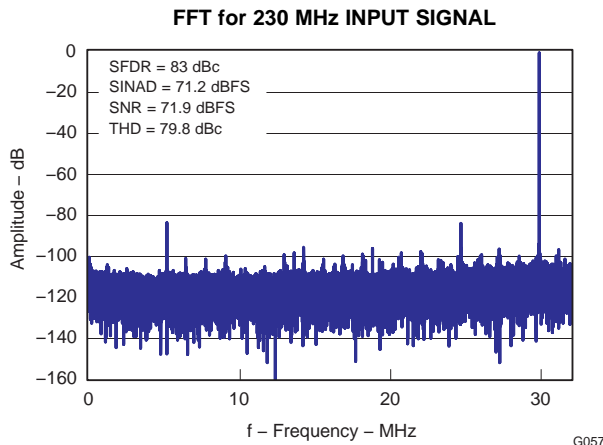

Figure 8.

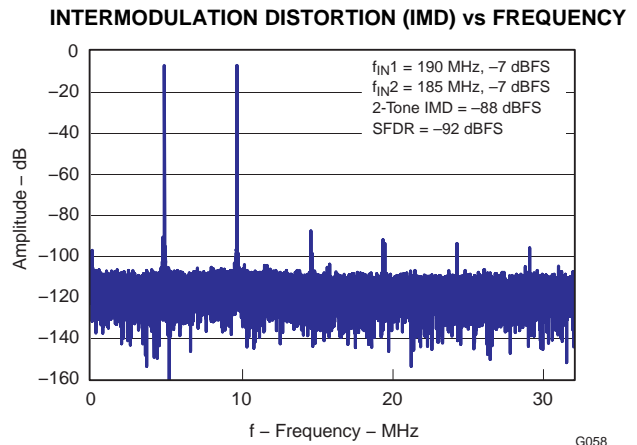

Figure 9.

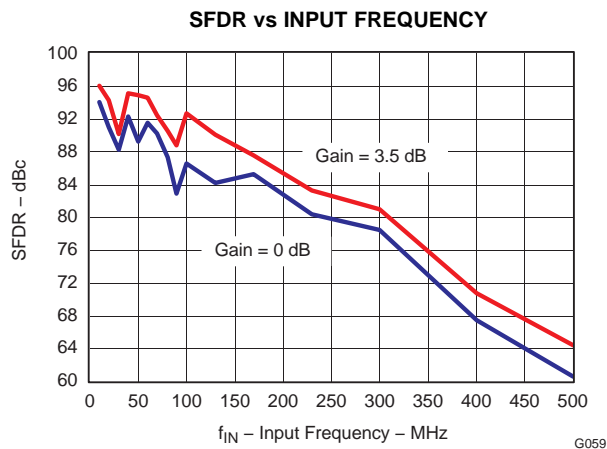

Figure 10.

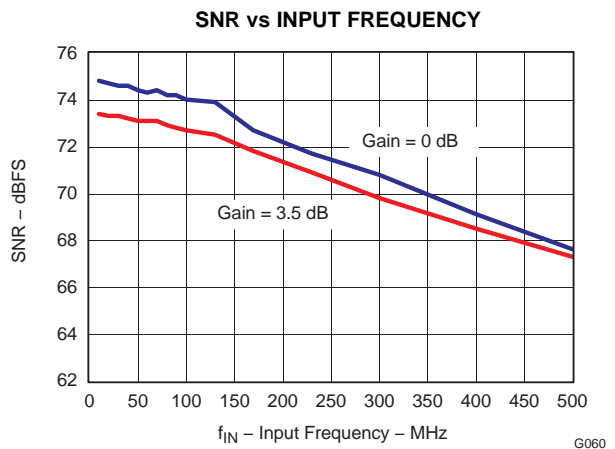

Figure 11.

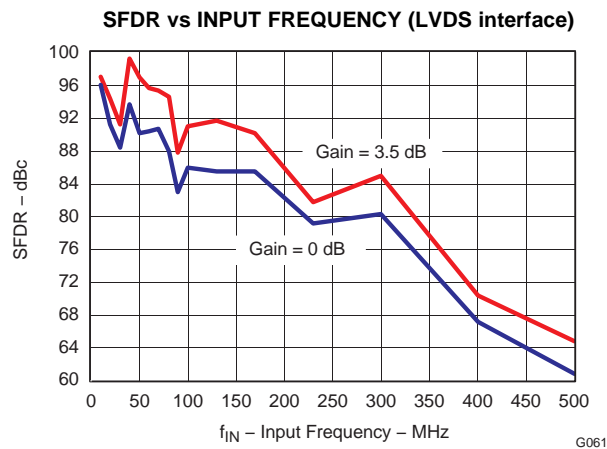

Figure 12.

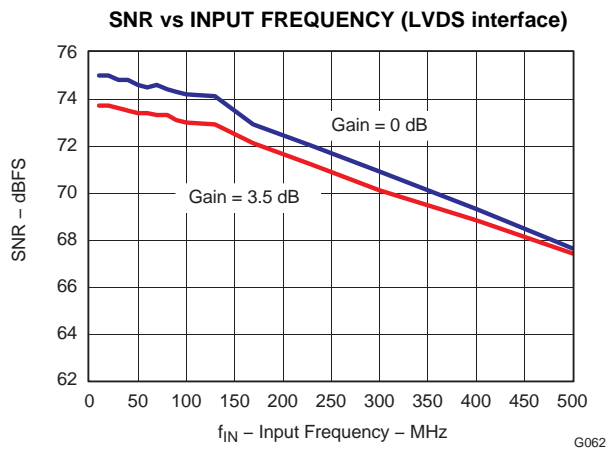

Figure 13.

TYPICAL CHARACTERISTICS (continued)

All plots are at 25°C, AVDD = DRVDD = 3.3 V, maximum rated sampling frequency, sine wave input clock, 1.5 V_{PP} differential clock amplitude, 50% clock duty cycle, -1 dBFS differential analog input, internal reference mode, 0 dB gain, CMOS output interface (unless otherwise noted)

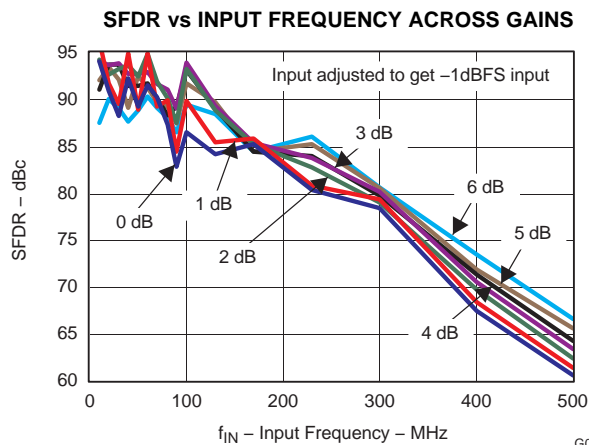

Figure 14.

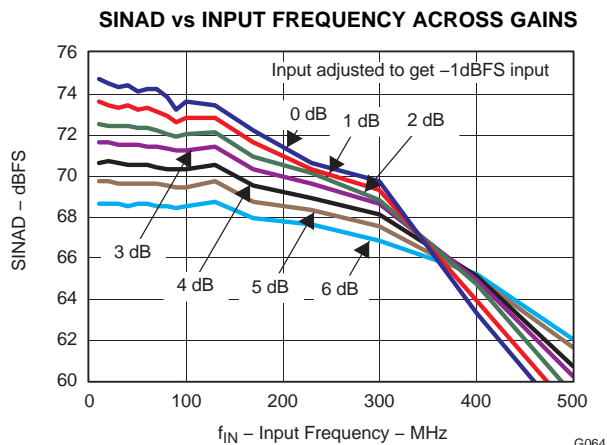

Figure 15.

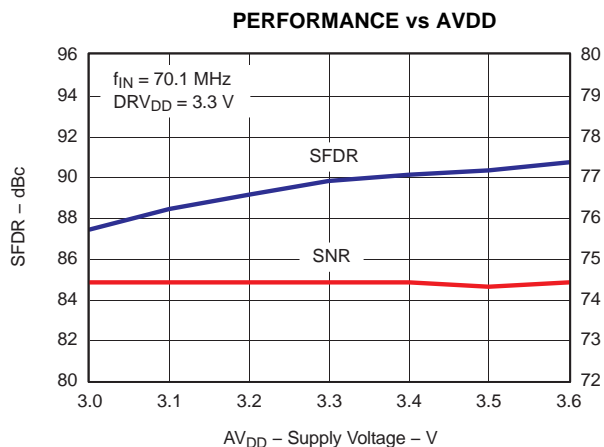

Figure 16.

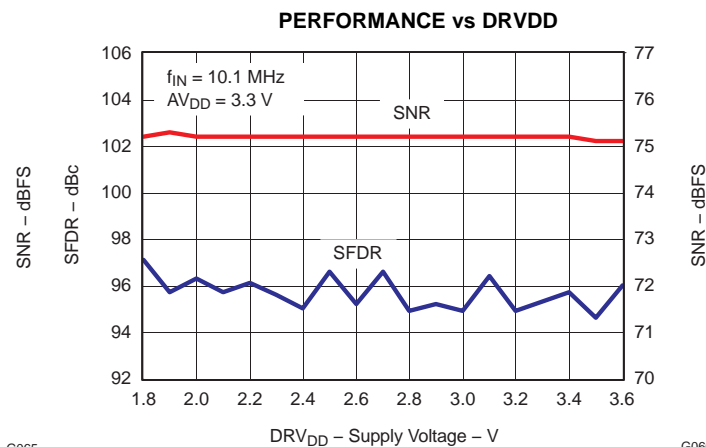

Figure 17.

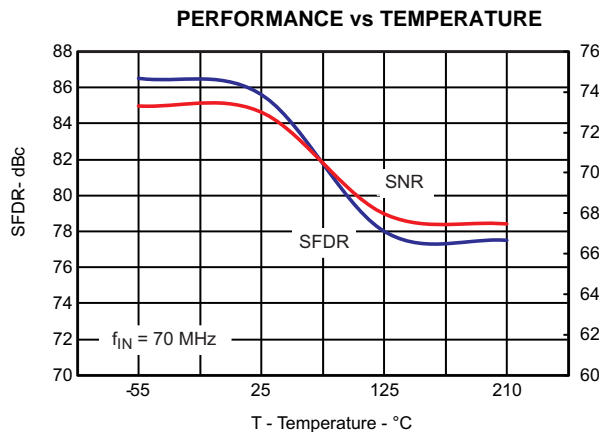

Figure 18.

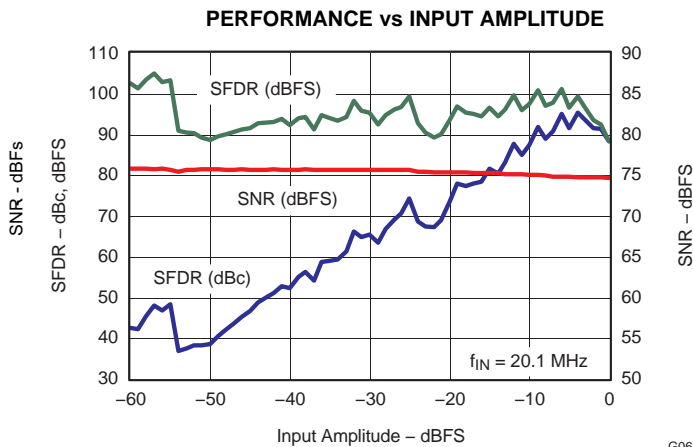

Figure 19.

TYPICAL CHARACTERISTICS (continued)

All plots are at 25°C, AVDD = DRVDD = 3.3 V, maximum rated sampling frequency, sine wave input clock, 1.5 V_{PP} differential clock amplitude, 50% clock duty cycle, -1 dBFS differential analog input, internal reference mode, 0 dB gain, CMOS output interface (unless otherwise noted)

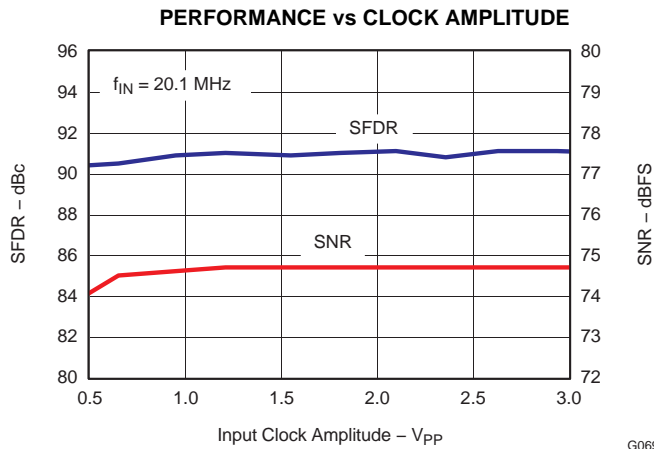

Figure 20.

G069

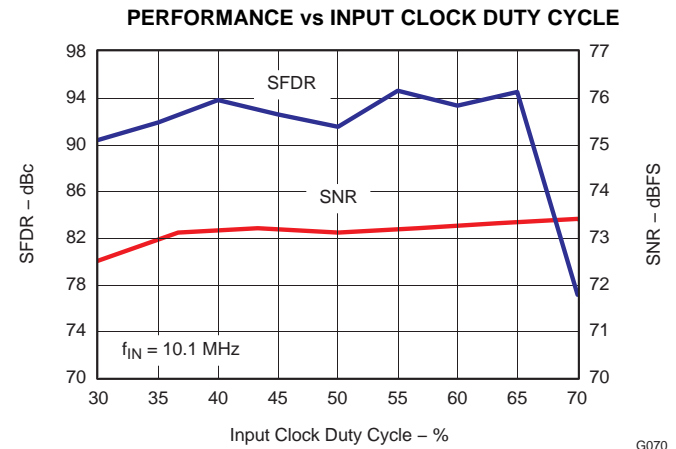

Figure 21.

G070

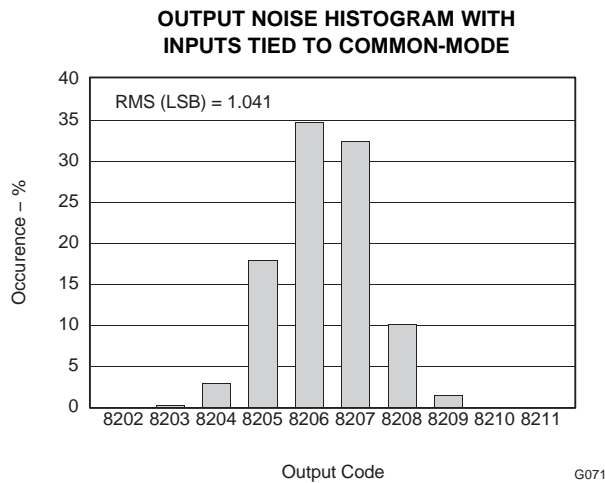

Figure 22.

G071

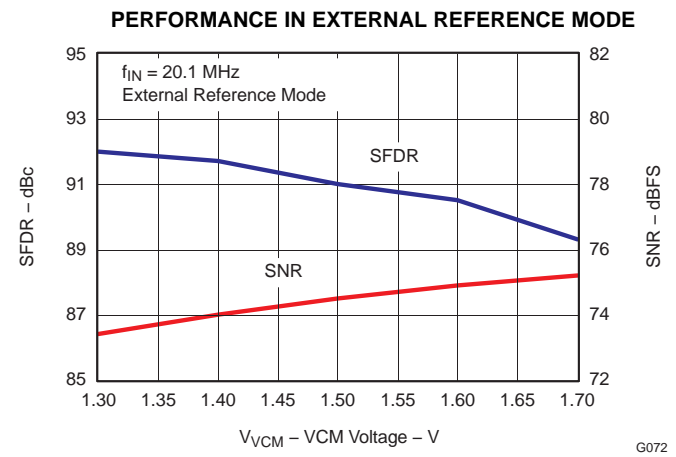

Figure 23.

G072

TYPICAL CHARACTERISTICS - LOW SAMPLING FREQUENCIES

All plots are at 25°C, AVDD = DRVDD = 3.3 V, sine wave input clock, 1.5 V_{PP} differential clock amplitude, 50% clock duty cycle, -1 dBFS differential analog input, internal reference mode, 0 dB gain, CMOS output interface (unless otherwise noted)

F_S = 40 MSPS

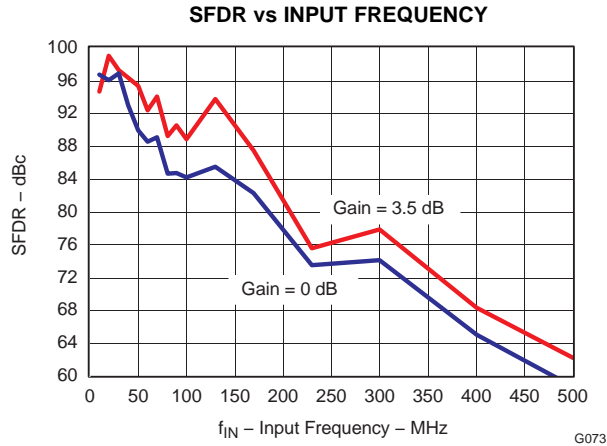

Figure 24.

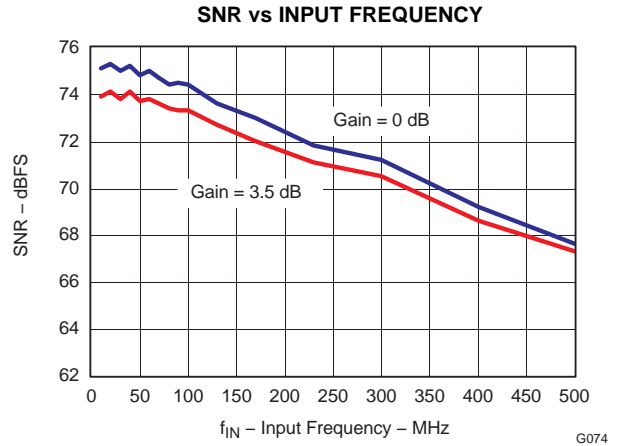

Figure 25.

F_S = 25 MSPS

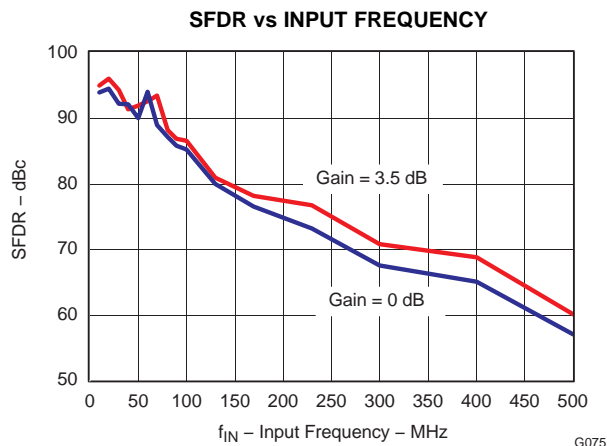

Figure 26.

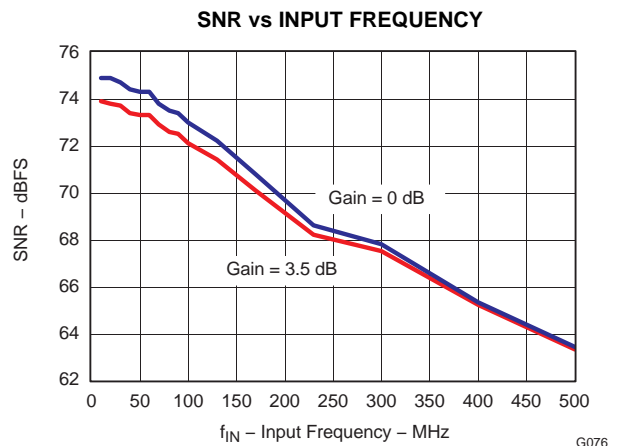

Figure 27.

COMMON PLOTS

All plots are at 25°C, AVDD = DRVDD = 3.3 V, sine wave input clock, 1.5 V_{PP} differential clock amplitude, 50% clock duty cycle, -1 dBFS differential analog input, internal reference mode, 0 dB gain, CMOS output interface (unless otherwise noted)

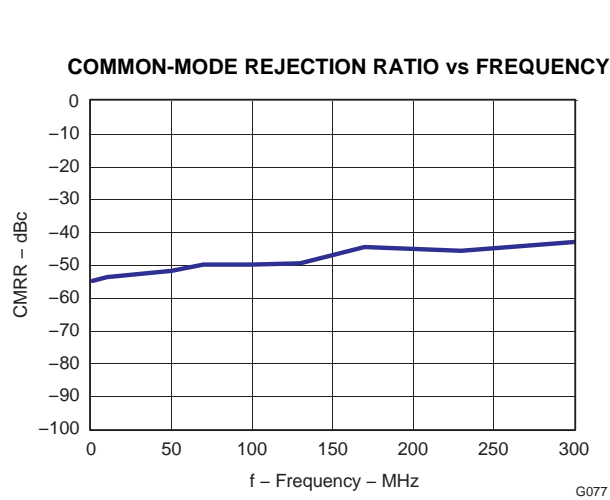

Figure 28.

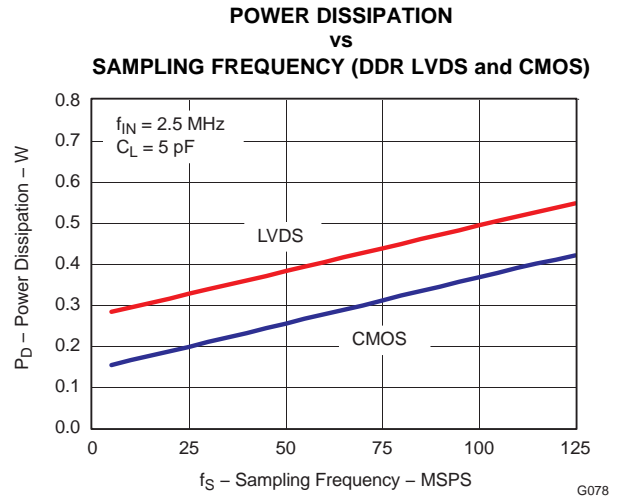

Figure 29.

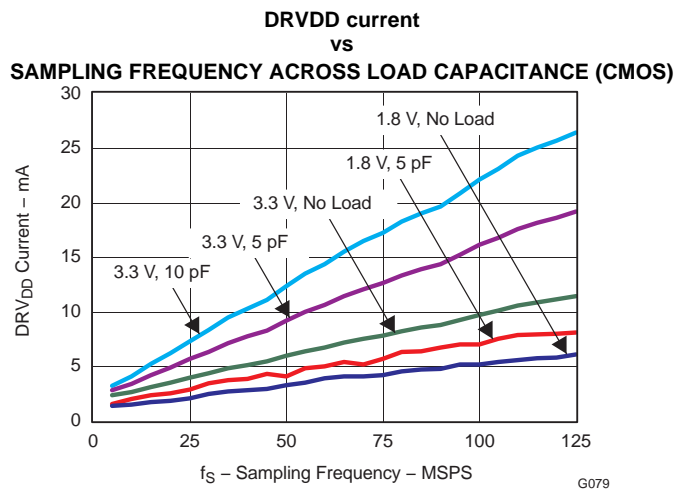
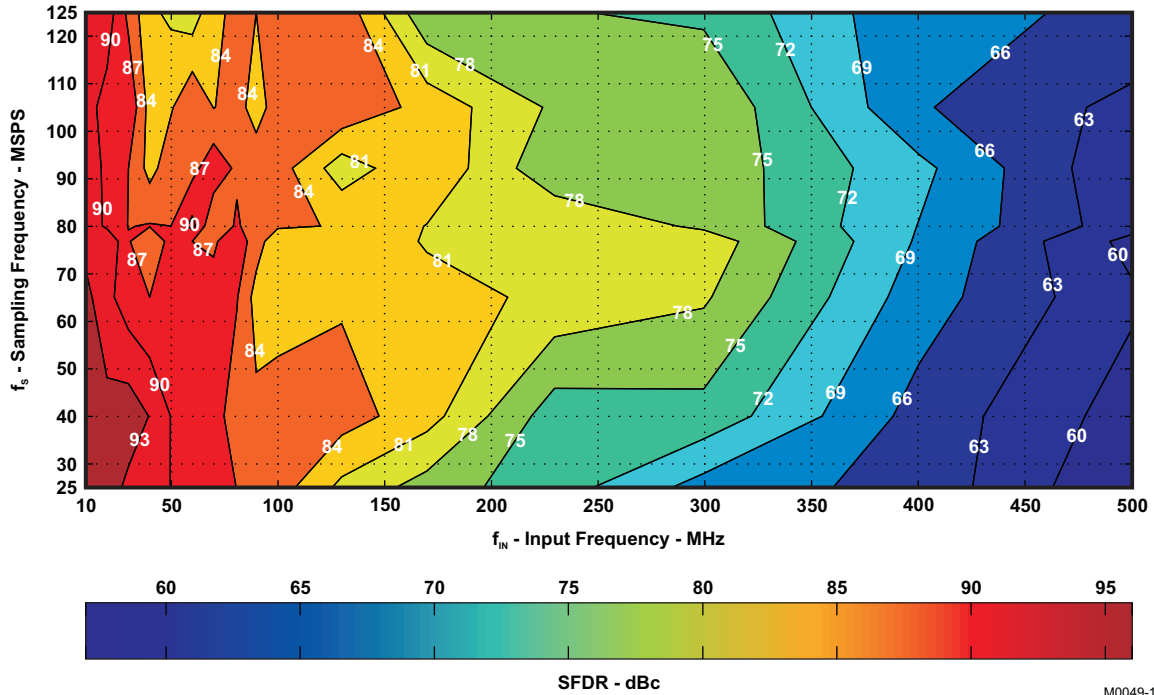

Figure 30.

Contour Plots Across Input and Sampling Frequencies



M0049-15

Figure 31. SFDR Contour (no gain, $F_S = 2 V_{PP}$)

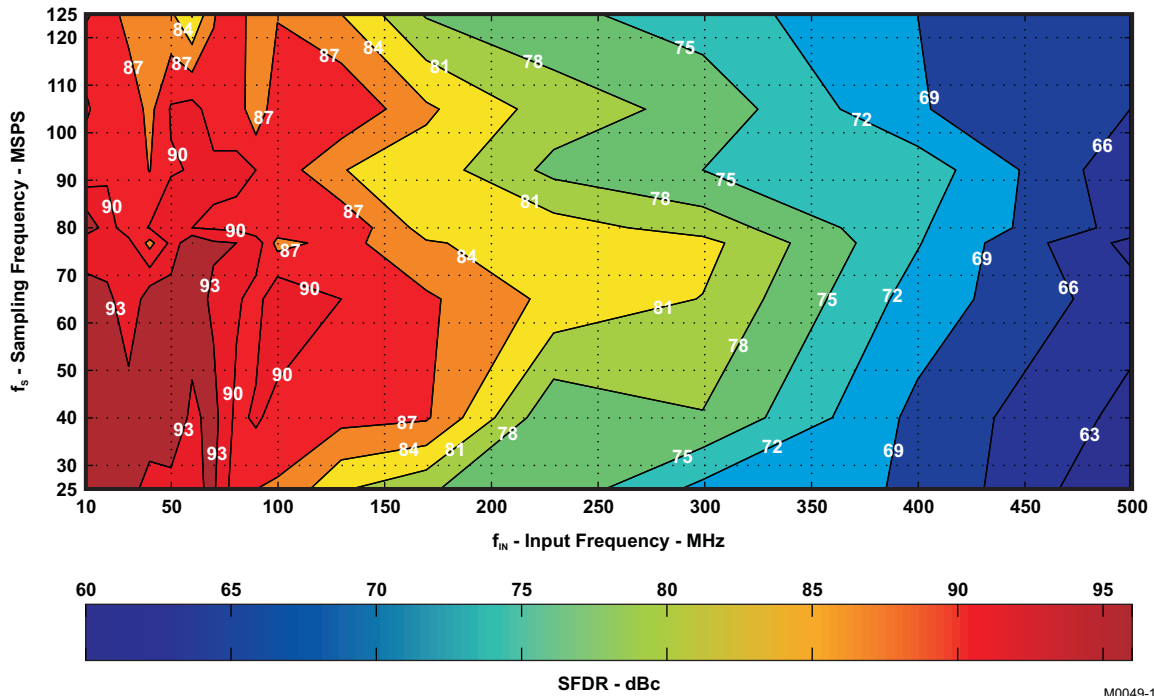

M0049-16

Figure 32. SFDR Contour (with 3.5 dB coarse gain, $F_S = 1.34 V_{PP}$)

Contour Plots Across Input and Sampling Frequencies (continued)

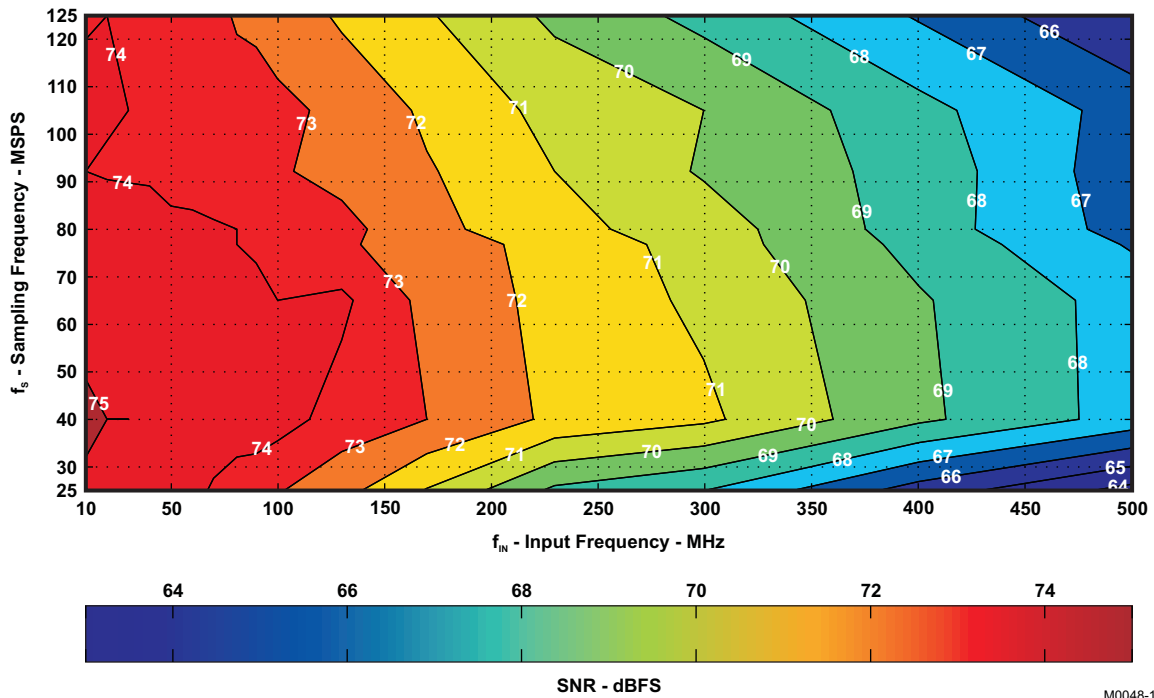

M0048-15

Figure 33. SNR Contour (no gain, $F_S = 2 V_{PP}$)

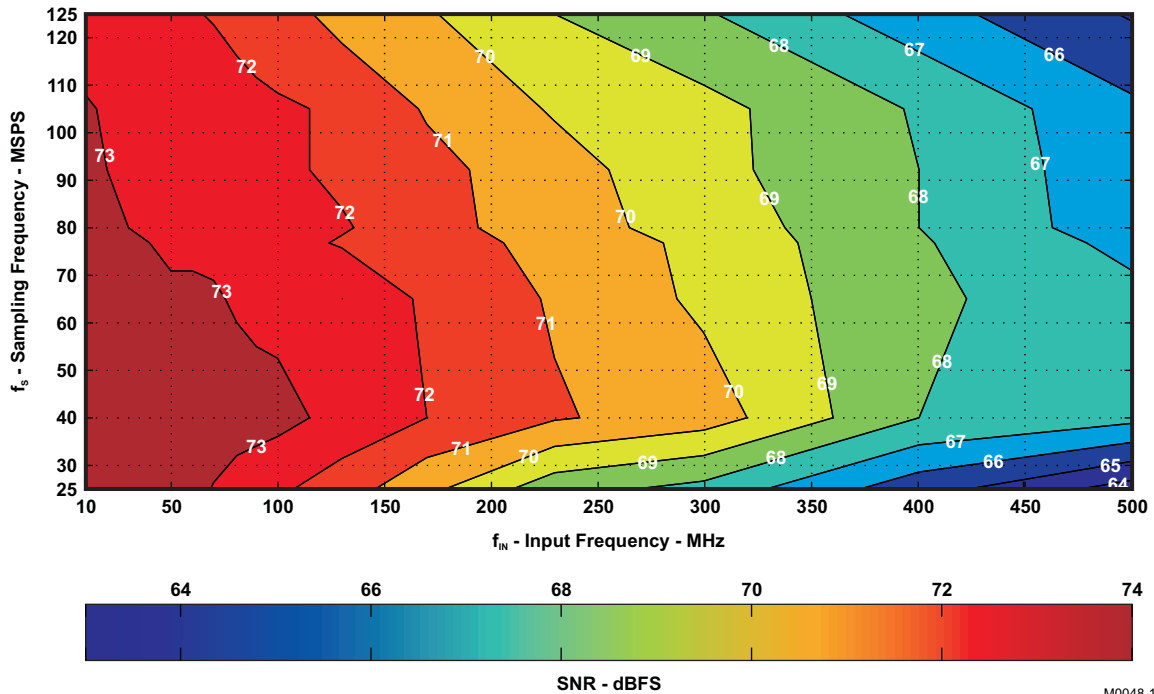

M0048-16

Figure 34. SNR Contour (with 3.5 dB coarse gain, $F_S = 1.34 V_{PP}$)

APPLICATION INFORMATION

THEORY OF OPERATION

The ADS6142 is a low power, 14-bit pipeline ADC in a CMOS process with a 65 MSPS sampling frequency. This device is based on switched capacitor technology and run off a single 3.3-V supply. The conversion process is initiated by the rising edge of the external input clock. Once the signal is captured by the input sample and hold, the input sample is sequentially converted by a series of lower resolution stages, with the outputs combined in a digital correction logic block. At every clock edge, the sample propagates through the pipeline resulting in a data latency of 9 clock cycles. The output is available as 14-bit data, in DDR LVDS or CMOS and coded in either straight offset binary or binary 2s complement format.

ANALOG INPUT

The analog input consists of a switched-capacitor based differential sample and hold architecture, shown in Figure 35.

This differential topology results in good ac-performance even for high input frequencies at high sampling rates. The INP and INM pins have to be externally biased around a common-mode voltage of 1.5 V available on the VCM pin. For a full-scale differential input, each input pin (INP, INM) has to swing symmetrically between $V_{CM} + 0.5\text{ V}$ and $V_{CM} - 0.5\text{ V}$, resulting in a $2V_{PP}$ differential input swing. The maximum swing is determined by the internal reference voltages REFP (2.5 V nominal) and REFM (0.5 V, nominal).

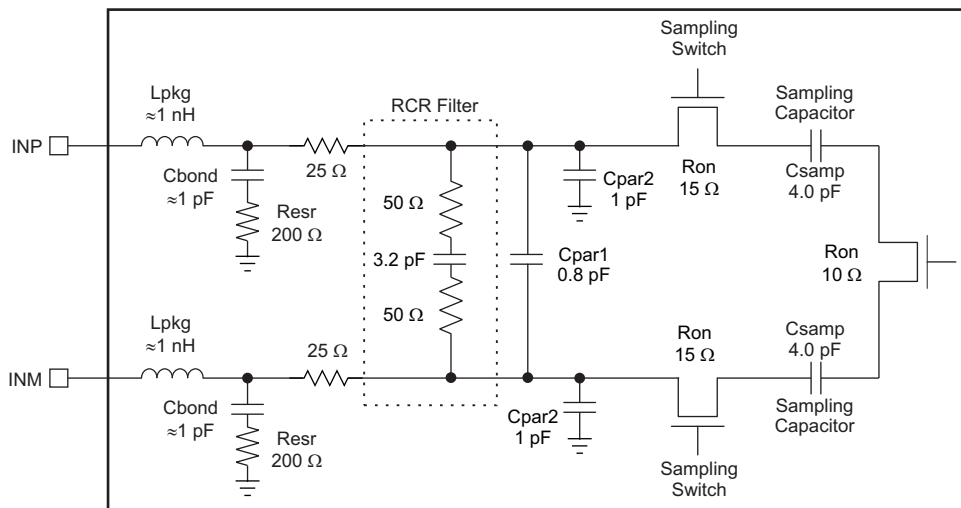

Figure 35. Input Stage

The input sampling circuit has a high 3dB bandwidth that extends up to 300 MHz (measured from the input pins to the voltage across the sampling capacitors).

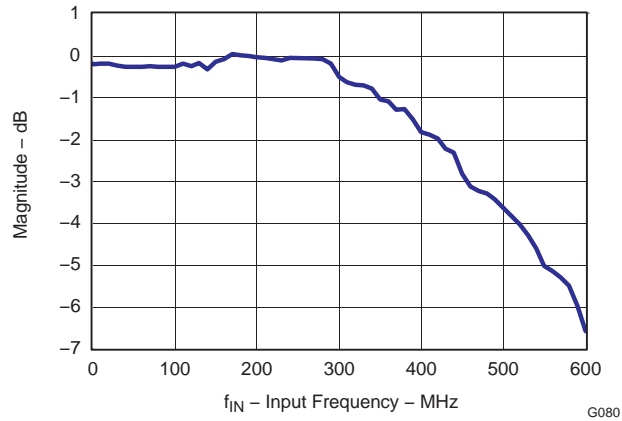

Figure 36. ADC Analog Input Bandwidth

Drive Circuit Requirements

For optimum performance, the analog inputs must be driven differentially. This improves the common-mode noise immunity and even-order harmonic rejection.

A 5- Ω resistor in series with each input pin is recommended to damp out ringing caused by the package parasitics. It is also necessary to present low impedance (< 50 Ω) for the common-mode switching currents. For example, this is achieved by using two resistors from each input terminated to the common-mode voltage (VCM).

In addition to the above, the drive circuit may have to be designed to provide a low insertion loss over the desired frequency range and matched impedance to the source. While doing this, the ADC input impedance (Z_{in}) must be considered. Over a wide frequency range, the input impedance can be approximated by a parallel combination of R_{in} and C_{in} ($Z_{in} = R_{in} || C_{in}$).

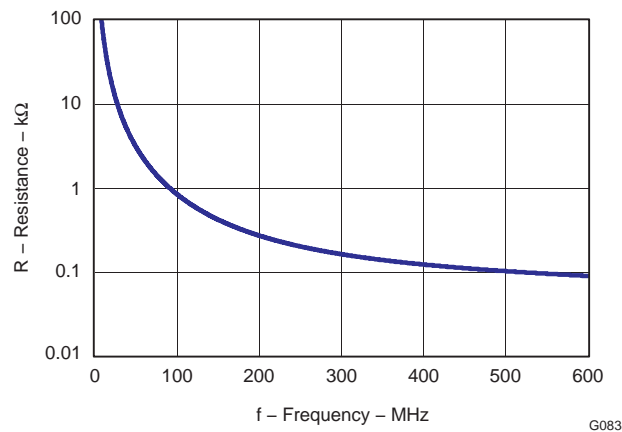

Figure 37. ADC Input Resistance, Rin

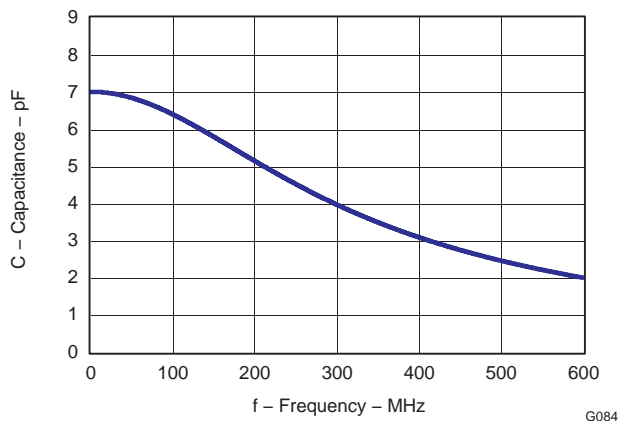

Figure 38. ADC Input Capacitance, C_{in}

Using RF-Transformer Based Drive Circuits

Figure 39 shows a configuration using a single 1:1 turn ratio transformer (for example, Coilcraft WBC1-1) that can be used for low input frequencies (about 100 MHz).

The single-ended signal is fed to the primary winding of the RF transformer. The transformer is terminated on the secondary side. Putting the termination on the secondary side helps to shield the kickbacks caused by the sampling circuit from the RF transformer’s leakage inductances. The termination is accomplished by two resistors connected in series, with the center point connected to the 1.5 V common mode (VCM pin). The value of the termination resistors (connected to common mode) has to be low ($< 100 \Omega$) to provide a low-impedance path for the ADC common-mode switching current.

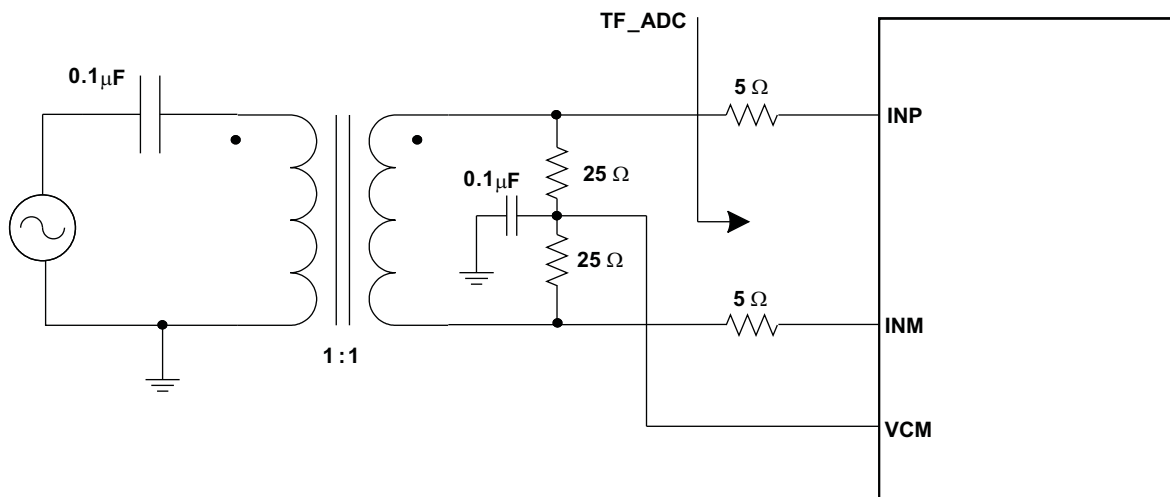
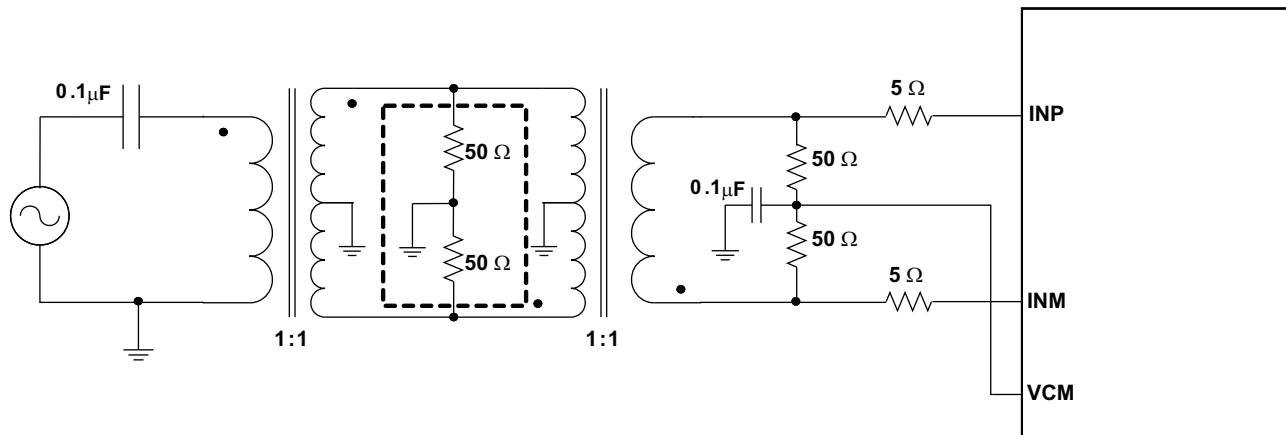

Figure 39. Single Transformer Drive Circuit

At high input frequencies, the mismatch in the transformer parasitic capacitance (between the windings) results in degraded even-order harmonic performance. Connecting two identical RF transformers back-to-back helps minimize this mismatch, and good performance is obtained for high frequency input signals. Figure 40 shows an example using two transformers (Coilcraft WBC1-1). An additional termination resistor pair (enclosed within the dotted box in Figure 40) may be required between the two transformers to improve the balance between the P and M sides. The center point of this termination must be connected to ground.

Figure 40. Two Transformer Drive Circuit

REFERENCE

The ADS6142 has built-in internal references REFP and REFM, requiring no external components. Design schemes are used to linearize the converter load seen by the references; this and the integration of the requisite reference capacitors on-chip eliminates the need for external decoupling. The full-scale input range of the converter is controlled in the external reference mode as explained below. The internal or external reference modes can be selected by programming the serial interface register bit <REF> (Table 7).

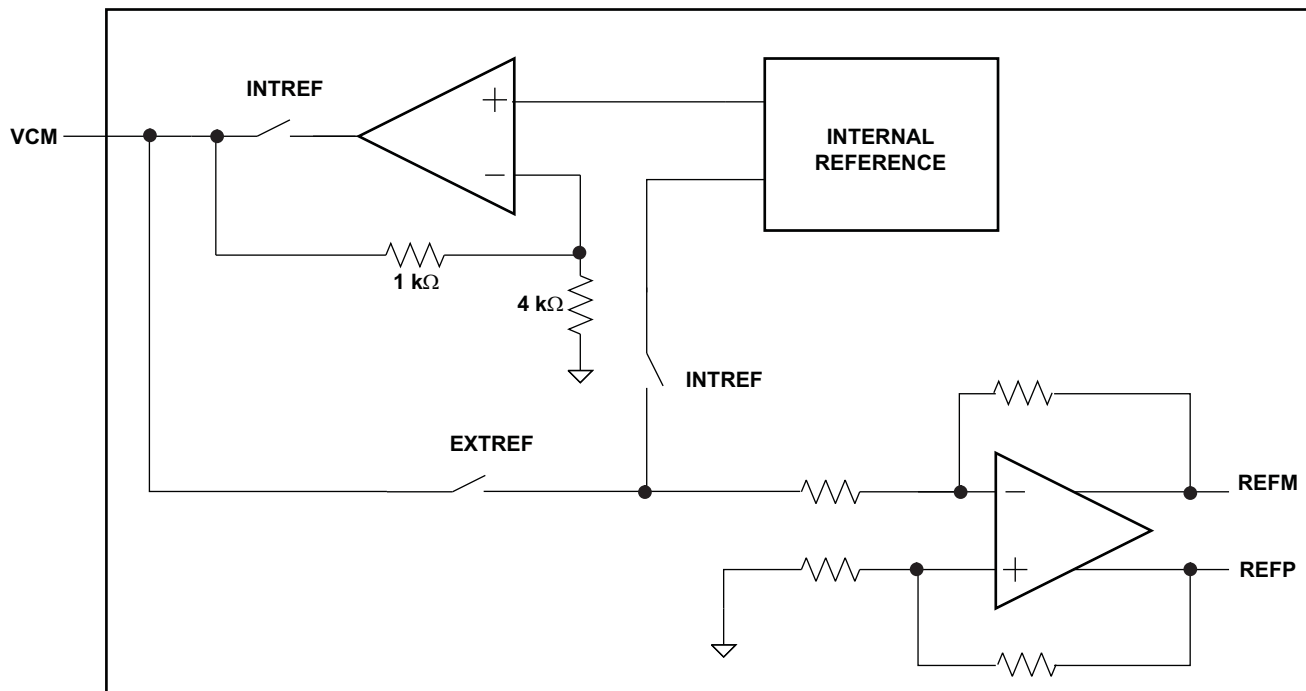
Figure 41. Reference Section

Internal Reference

When the device is in internal reference mode, the REFP and REFM voltages are generated internally. Common-mode voltage (1.5 V nominal) is output on the VCM pin, which can be used to externally bias the analog input pins.

External Reference

When the device is in external reference mode, VCM acts as a reference input pin. The voltage forced on the VCM pin is buffered and gained by 1.33 internally, generating the REFP and REFM voltages. The differential input voltage corresponding to full-scale is given by [Equation 1](#).

$$\text{Full-scale differential input pp} = (\text{Voltage forced on VCM}) \times 1.33 \quad (1)$$

In this mode, the 1.5-V common-mode voltage to bias the input pins has to be generated externally. There is no change in performance compared to internal reference mode.

COARSE GAIN AND PROGRAMMABLE FINE GAIN

The ADS6142 includes gain settings that can be used to improve SFDR performance (compared to 0 dB gain mode). The gain settings are 3.5 dB coarse gain and 0 dB to 6 dB programmable fine gain. For each gain setting, the analog input full-scale range scales proportionally, as shown in [Table 15](#).

The coarse gain is a fixed setting of 3.5 dB and is designed to improve SFDR with little degradation in SNR. The fine gain is programmable in 1 dB steps from 0 dB to 6 dB. With fine gain, SFDR improvement is also achieved, but at the expense of SNR (there is about 1 dB SNR degradation for every 1 dB of fine gain).

So, the fine gain can be used to trade-off between SFDR and SNR. The coarse gain makes it possible to get the best SFDR but without losing SNR significantly. At high input frequencies, the gains are especially useful as the SFDR improvement is significant with marginal degradation in SINAD. The gains can be programmed using the register bits <COARSE GAIN> (see [Table 7](#)) and <FINE GAIN> (see [Table 12](#)). Note that the default gain after reset is 0 dB.

Table 15. Full-Scale Range Across Gains

GAIN, dB	TYPE	FULL-SCALE RANGE, V _{PP}
0	Default after reset	2.00
3.5	Coarse setting (fixed)	1.34
1	Fine gain (programmable)	1.78
2		1.59
3		1.42
4		1.26
5		1.12
6		1.00

CLOCK INPUT

The clock inputs of the ADS6142 can be driven differentially (SINE, LVPECL, or LVDS) or single-ended (LVCMOS), with little or no difference in performance between configurations. The common-mode voltage of the clock inputs is set to VCM using internal 5-k Ω resistors as shown in Figure 42. This allows the use of transformer-coupled drive circuits for the sine wave clock, or ac-coupling for the LVPECL, LVDS clock sources (see Figure 44 and Figure 45).

For best performance, it is recommended to drive the clock inputs differentially, reducing susceptibility to common-mode noise. In this case, it is best to connect both clock inputs to the differential input clock signal with 0.1- μ F capacitors, as shown in Figure 44. A single-ended CMOS clock can be ac-coupled to the CLKP input, with CLKM connected to ground with a 0.1- μ F capacitor, as shown in Figure 45.

For high input frequency sampling, a clock source with very low jitter is recommended. Band-pass filtering of the clock source can help reduce the effect of jitter. There is no change in performance with a non-50% duty cycle clock input.

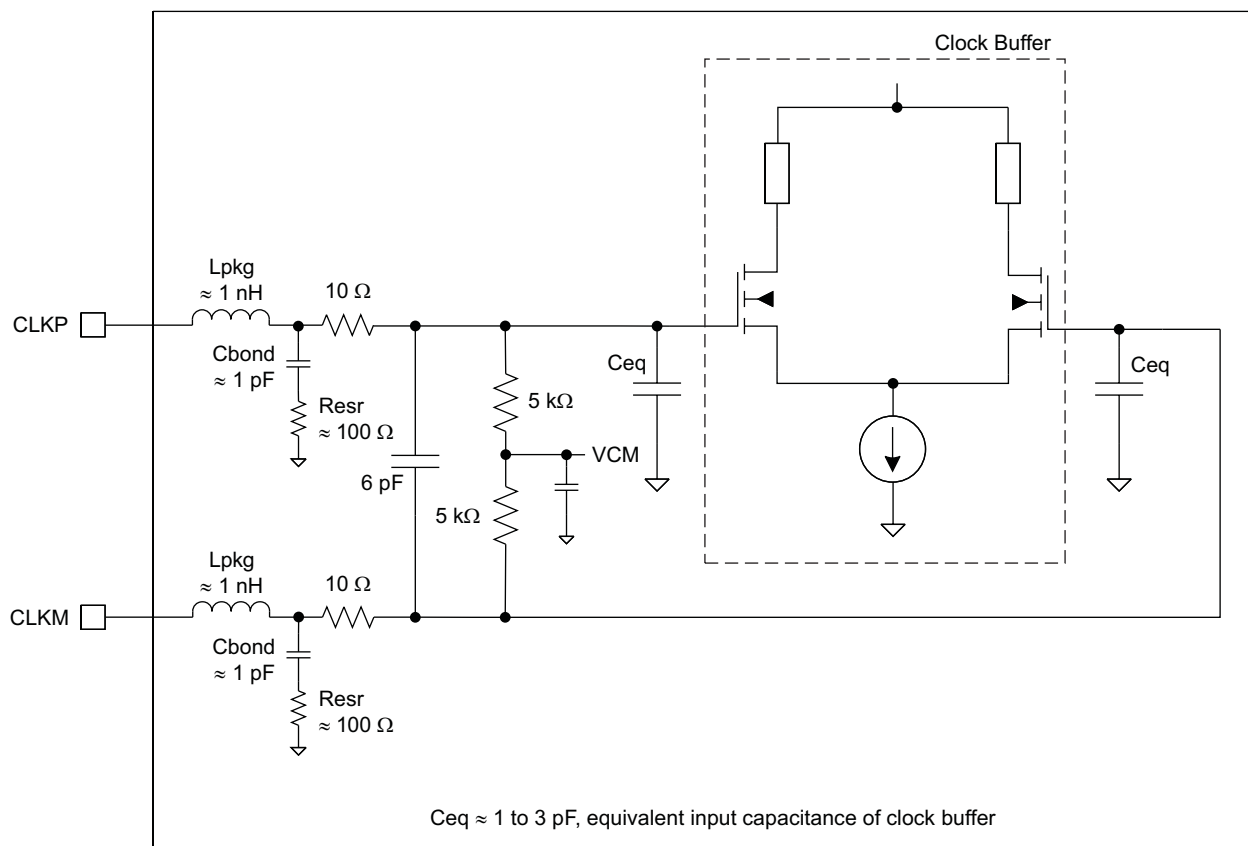

Figure 42. Internal Clock Buffer

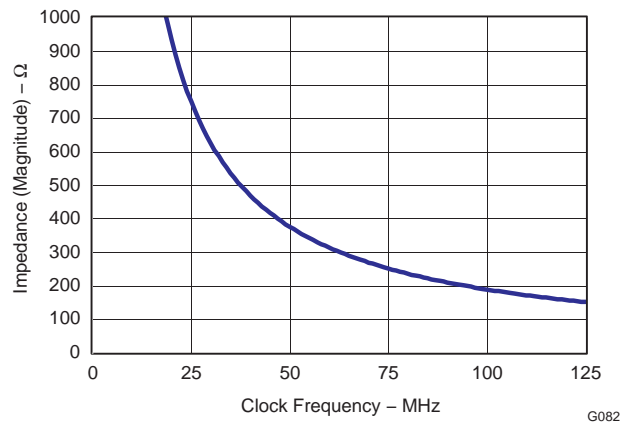

Figure 43. Clock Buffer Input Impedance

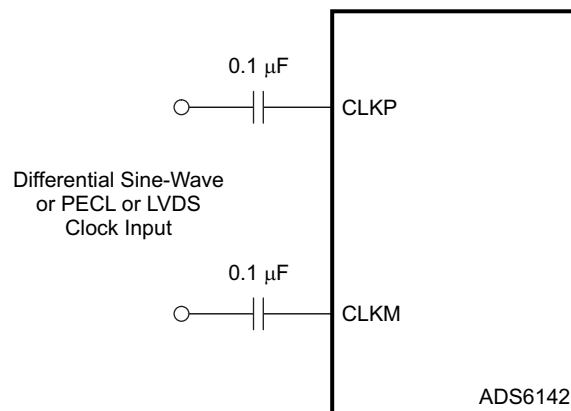

Figure 44. Differential Clock Driving Circuit

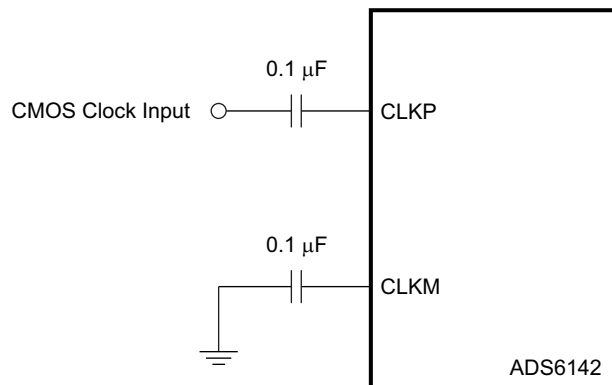

Figure 45. Single-Ended Clock Driving Circuit

POWER-DOWN MODES

The ADS6142 has four power-down modes – global power down, standby, output buffer disable, and input clock stopped. These modes can be set using the serial interface or using the parallel interface (pins SDATA and PDN).

Table 16. Power-Down Modes

POWER-DOWN MODES	PARALLEL INTERFACE		SERIAL INTERFACE REGISTER BIT (Table 7)	TOTAL POWER, mW	WAKE-UP TIME (to valid data)
	SDATA	PDN			
Normal operation	Low	Low	<PDN OBUF>=0 and <STBY>=0	417	-
Standby	Low	High	<PDN OBUF>=0 and <STBY>=1	72	Slow (15 μ s)
Output buffer disable	High	Low	<PDN OBUF>=1 and <STBY>=0	408	Fast (200 ns)
Global power down	High	High	<PDN OBUF>=1 and <STBY>=1	30	Slow (15 μ s)

Global Power Down

In this mode, the A/D converter, internal references, and the output buffers are powered down and the total power dissipation reduces to about 30 mW. The output buffers are in a high-impedance state. The wake-up time from the global power down to output data becoming valid in normal mode is a maximum of 50 μ s. Note that after coming out of global power down, optimum performance is achieved after the internal reference voltages have stabilized (about 1 ms).

Standby

Only the A/D converter is powered down and total power dissipation is approximately 72 mW. The wake-up time from standby to output data becoming valid is a maximum of 50 μ s.

Output Buffer Disable

The data output buffers can be disabled, reducing total power to about 408 mW. With the buffers disabled, the outputs are in a high-impedance state. The wake-up time from this mode to data becoming valid in normal mode is a maximum of 500 ns in LVDS mode and 200 ns in CMOS mode.

Input Clock Stop

The converter enters this mode when the input clock frequency falls below 1 MSPS. Power dissipation is approximately 120 mW, and the wake-up time from this mode to data becoming valid in normal mode is a maximum of 50 μ s.

Power Supply Sequence

During power-up, the AVDD and DRVDD supplies can come up in any sequence. The two supplies are separated inside the device. Externally, they can be driven from separate supplies or from a single supply.

DIGITAL OUTPUT INTERFACE

The ADS6142 outputs 14 data bits together with an output clock. The output interface is either parallel CMOS or DDR LVDS voltage levels and can be selected using the serial register bit <LVDS CMOS> or parallel pin SEN.

Parallel CMOS Interface

In CMOS mode, the output buffer supply (DRVDD) can be operated over a wide range from 1.8 V to 3.3 V (typical). Each data bit is output on a separate pin as a CMOS voltage level, every clock cycle.

For $DRVDD \geq 2.2$ V, it is recommended to use the CMOS output clock (CLKOUT) to latch data in the receiving chip. The rising edge of CLKOUT can be used to latch data in the receiver, even at the highest sampling speed (125 MSPS). It is recommended to minimize the load capacitance seen by the data and clock output pins by using short traces to the receiver. Also, match the output data and clock traces to minimize the skew between them.

For $DRVDD < 2.2$ V, it is recommended to use an external clock (for example, input clock delayed to get desired setup/hold times).

Output Clock Position Programmability

There is an option to shift (delay) the output clock position so that the setup time increases by 400 ps (typical, with respect to the default timings specified). This may be useful if the receiver needs more setup time, especially at high sampling frequencies. This can be programmed using the serial interface register bit <CLKOUT_POSN> (Table 8).

Output Buffer Strength Programmability

Switching noise (caused by CMOS output data transitions) can couple into the analog inputs during the instant of sampling and degrade the SNR. The coupling and SNR degradation increases as the output buffer drive is made stronger. To minimize this, the ADS6142 CMOS output buffers are designed with a controlled drive strength for the best SNR. The default drive strength also ensures a wide data stable window for load capacitances up to 5 pF and a DRVDD supply voltage ≥ 2.2 V.

To ensure a wide data stable window for load capacitances > 5 pF, there is an option to increase the drive strength using the serial interface (<DRIVE STRENGTH>, see Table 14). Note that for a DRVDD supply voltage < 2.2 V, it is recommended to use the maximum drive strength (for any value of load capacitance).

CMOS Mode Power Dissipation

With CMOS outputs, the DRVDD current scales with the sampling frequency and the load capacitance on every output pin. The maximum DRVDD current occurs when each output bit toggles between 0 and 1 every clock cycle. In actual applications, this condition is unlikely to occur. The actual DRVDD current would be determined by the average number of output bits switching, which is a function of the sampling frequency and the nature of the analog input signal.

$$\text{Digital current due to CMOS output switching} = C_L \times DRVDD \times (N \times F_{AVG})$$

$$\text{where } C_L = \text{load capacitance, } N \times F_{AVG} = \text{average number of output bits switching} \quad (2)$$

Figure 30 shows the current with various load capacitances across sampling frequencies with a 2-MHz analog input frequency.

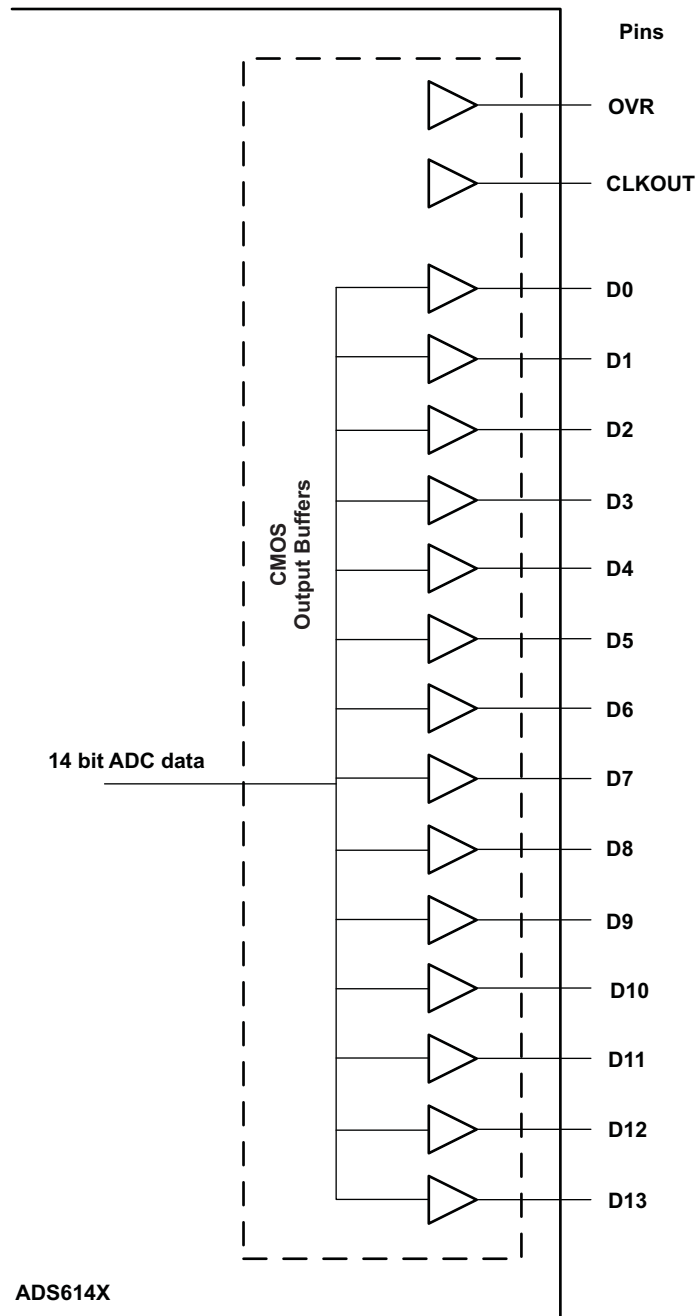

Figure 46. CMOS Output Buffers

DDR LVDS Interface

The LVDS interface works only with a 3.3-V DRVDD supply. In this mode, the 14 data bits and the output clock are available as LVDS (Low Voltage Differential Signal) levels. Two successive data bits are multiplexed and output on each LVDS differential pair every clock cycle (DDR - Double Data Rate, see Figure 47). So, there are 7 LVDS output pairs for the 14 data bits and 1 LVDS output pair for the output clock.

LVDS Buffer Current Programmability

The default LVDS buffer output current is 3.5 mA. When terminated by 100 Ω, this results in a 350-mV single-ended voltage swing (700-mV_{PP} differential swing). The LVDS buffer currents can also be programmed to 2.5 mA, 4.5 mA, and 1.75 mA (register bits <LVDS CURRENT>, see Table 13). In addition, there is a current double mode, where this current is doubled for the data and output clock buffers (register bits <CURRENT DOUBLE>, see Table 13).

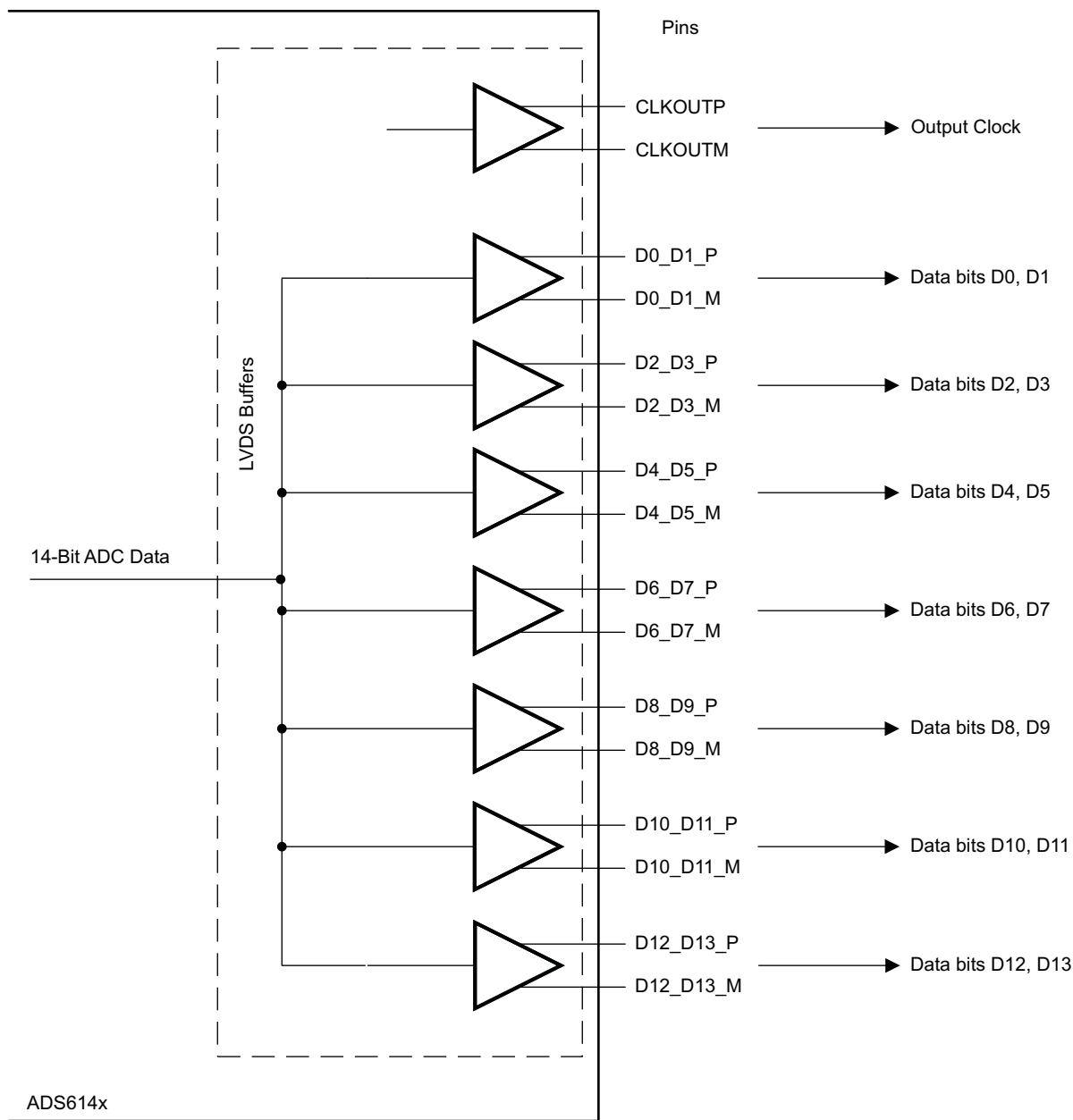

Figure 47. DDR LVDS Outputs

Even data bits D0, D2, D4, D6, D8, D10, and D12 are output at the rising edge of CLKOUTP and the odd data bits D1, D3, D5, D7, D9, D11, and D13 are output at the falling edge of CLKOUTP. Both the rising and falling edges of CLKOUTP must be used to capture all 14 data bits (see [Figure 48](#)).

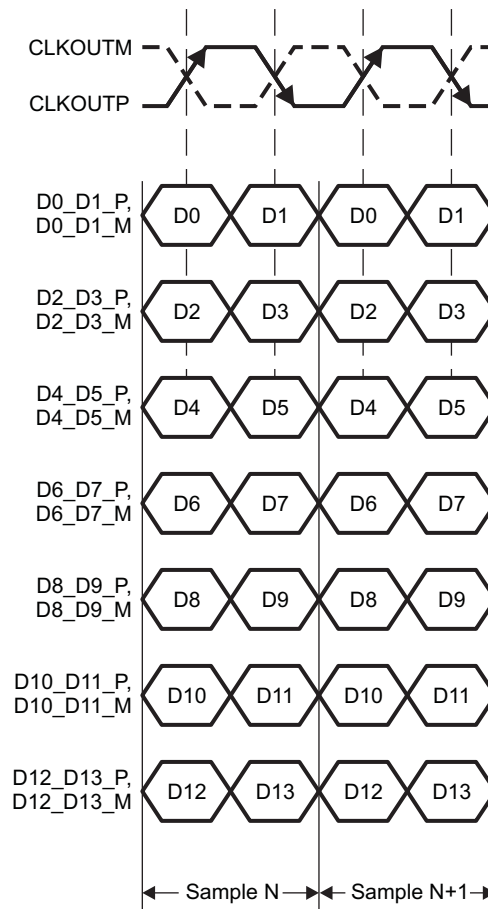

Figure 48. DDR LVDS Interface

LVDS Buffer Internal Termination

An internal termination option is available (using the serial interface), by which the LVDS buffers are differentially terminated inside the device. The termination resistances available are – 300 Ω , 185 Ω , and 150 Ω (nominal with $\pm 20\%$ variation). Any combination of these three terminations can be programmed; the effective termination is the parallel combination of the selected resistances. This results in eight effective terminations from open (no termination) to 65 Ω .

The internal termination helps to absorb any reflections coming from the receiver end, improving the signal integrity. With 100- Ω internal and 100- Ω external termination, the voltage swing at the receiver end is halved (compared to no internal termination). The voltage swing can be restored by using the LVDS current double mode. [Figure 49](#) and [Figure 50](#) compare the LVDS eye diagrams without and with internal termination (100 Ω). With internal termination, the eye looks clean even with 10-pF load capacitance (from each output pin to ground). The termination is programmed using register bits <DATA TERM> and <CLKOUT TERM> (see [Table 13](#)).

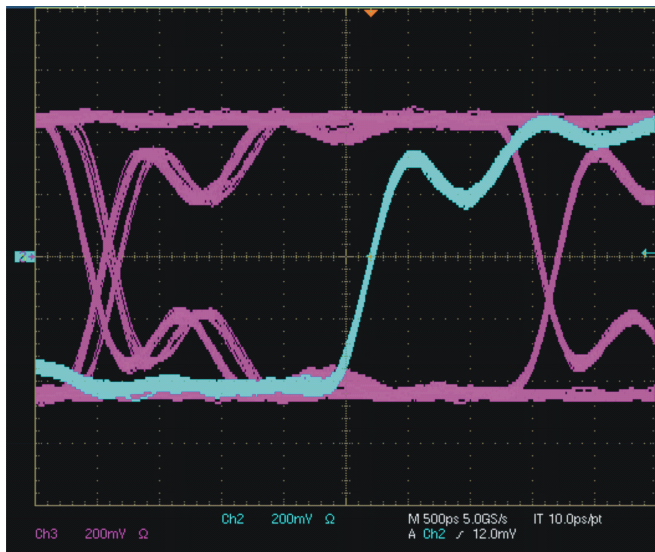

Figure 49. LVDS Eye Diagram - No Internal Termination
5-pF Load Capacitance
Blue Trace - Output Clock (CLKOUT)
Pink Trace - Output Data

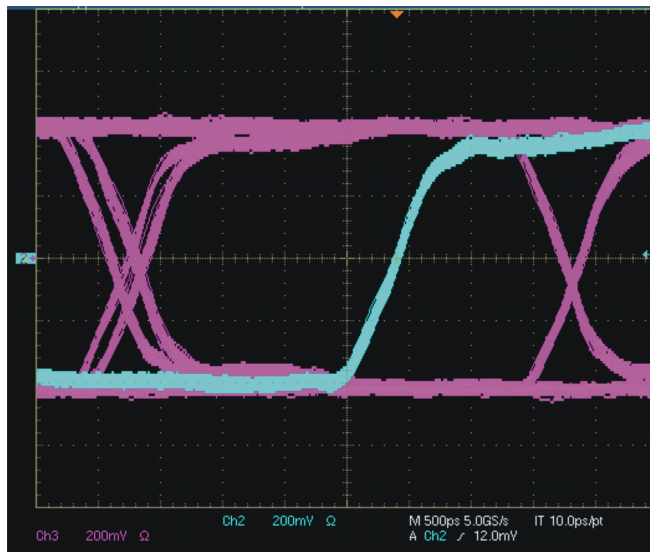

Figure 50. LVDS Eye Diagram with 100-Ω Internal Termination
10-pF Load Capacitance
Blue Trace - Output Clock (CLKOUT)
Pink Trace - Output Data

Output Data Format

Two output data formats are supported – 2s complement and offset binary. They can be selected using the parallel control pin SEN or the serial interface register bit <DATA FORMAT> (see Table 10).

Output Timings

The tables below show the timings at lower sampling frequencies.

Table 17. Timing Characteristics at Lower Sampling Frequencies (1) (2)

F _s , MSPS	t _{su} DATA SETUP TIME, ns			t _h DATA HOLD TIME, ns			t _{pDI} CLOCK PROPAGATION DELAY, ns		
	MIN	TYP	MAX	MIN	TYP	MAX	MIN	TYP	MAX
CMOS INTERFACE, DRVDD = 2.5 V to 3.3 V									
40		12.8			11.2			6.5	
20		25			23				
10		50			48				
DDR LVDS INTERFACE, DRVDD = 3.3 V									
40		10.8			1.7			5.8	
20		23			1.7			6.5	
10		48			1.7			6.5	

(1) Timing parameters are specified by design and not tested in production.
 (2) Timings are specified with default output buffer drive strength and C_L = 5 pF.

BOARD DESIGN CONSIDERATIONS

Grounding

A single ground plane is sufficient to give good performance, provided the analog, digital, and clock sections of the board are cleanly partitioned. See the EVM User Guide ([SLWU028](#)) for details on layout and grounding.

Supply Decoupling

As the ADS6142 already includes internal decoupling, minimal external decoupling can be used without loss in performance. Note that decoupling capacitors can help filter external power supply noise, so the optimum number of capacitors would depend on the actual application. The decoupling capacitors should be placed very close to the converter supply pins.

It is recommended to use separate supplies for the analog and digital supply pins to isolate digital switching noise from sensitive analog circuitry. In case only a single 3.3-V supply is available, it should be routed first to AVDD. It can then be tapped and isolated with a ferrite bead (or inductor) with decoupling capacitor, before being routed to DRVDD.

Exposed Thermal Pad

It is necessary to solder the exposed pad at the bottom of the package to a ground plane for best thermal performance. For detailed information, see application notes **QFN Layout Guidelines** ([SLOA122](#)) and **QFN/SON PCB Attachment** ([SLUA271](#)).

DEFINITION OF SPECIFICATIONS

Analog Bandwidth

The analog input frequency at which the power of the fundamental is reduced by 3 dB with respect to the low frequency value.

Aperture Delay

The delay in time between the rising edge of the input sampling clock and the actual time at which the sampling occurs.

Aperture Uncertainty (Jitter)

The sample-to-sample variation in aperture delay.

Clock Pulse Width/Duty Cycle

The duty cycle of a clock signal is the ratio of the time the clock signal remains at a logic high (clock pulse width) to the period of the clock signal. Duty cycle is typically expressed as a percentage. A perfect differential sine-wave clock results in a 50% duty cycle.

Maximum Conversion Rate

The maximum sampling rate at which certified operation is given. All parametric testing is performed at this sampling rate unless otherwise noted.

Minimum Conversion Rate

The minimum sampling rate at which the ADC functions.

Differential Nonlinearity (DNL)

An ideal ADC exhibits code transitions at analog input values spaced exactly 1 LSB apart. The DNL is the deviation of any single step from this ideal value, measured in units of LSBs.

Integral Nonlinearity (INL)

The INL is the deviation of the ADC's transfer function from a best fit line determined by a least squares curve fit of that transfer function, measured in units of LSBs.

Gain Error

The gain error is the deviation of the ADC's actual input full-scale range from its ideal value. The gain error is given as a percentage of the ideal input full-scale range.

Offset Error

The offset error is the difference, given in number of LSBs, between the ADC's actual average idle channel output code and the ideal average idle channel output code. This quantity is often mapped into mV.

Temperature Drift

The temperature drift coefficient (with respect to gain error and offset error) specifies the change per degree Celsius of the parameter from T_{MIN} to T_{MAX} . It is calculated by dividing the maximum deviation of the parameter across the T_{MIN} to T_{MAX} range by the difference $T_{\text{MAX}} - T_{\text{MIN}}$.

Signal-to-Noise Ratio

SNR is the ratio of the power of the fundamental (P_S) to the noise floor power (P_N), excluding the power at dc and the first nine harmonics.

$$\text{SNR} = 10\text{Log}_{10} \frac{P_S}{P_N} \quad (3)$$

SNR is either given in units of dBc (dB to carrier) when the absolute power of the fundamental is used as the reference, or dBFS (dB to full scale) when the power of the fundamental is extrapolated to the converter's full-scale range.

Signal-to-Noise and Distortion (SINAD)

SINAD is the ratio of the power of the fundamental (P_S) to the power of all the other spectral components including noise (P_N) and distortion (P_D), but excluding dc.

$$\text{SINAD} = 10\text{Log}_{10} \frac{P_S}{P_N + P_D} \quad (4)$$

SINAD is either given in units of dBc (dB to carrier) when the absolute power of the fundamental is used as the reference, or dBFS (dB to full scale) when the power of the fundamental is extrapolated to the converter's full-scale range.

Effective Number of Bits (ENOB)

The ENOB is a measure of a converter's performance as compared to the theoretical limit based on quantization noise.

$$\text{ENOB} = \frac{\text{SINAD} - 1.76}{6.02} \quad (5)$$

Total Harmonic Distortion (THD)

THD is the ratio of the power of the fundamental (P_S) to the power of the first nine harmonics (P_D).

$$\text{THD} = 10\text{Log}_{10} \frac{P_S}{P_D} \quad (6)$$

THD is typically given in units of dBc (dB to carrier).

Spurious-Free Dynamic Range (SFDR)

The ratio of the power of the fundamental to the highest other spectral component (either spur or harmonic). SFDR is typically given in units of dBc (dB to carrier).

Two-Tone Intermodulation Distortion

IMD3 is the ratio of the power of the fundamental (at frequencies f_1 and f_2) to the power of the worst spectral component at either frequency $2f_1 - f_2$ or $2f_2 - f_1$. IMD3 is either given in units of dBc (dB to carrier) when the absolute power of the fundamental is used as the reference, or dBFS (dB to full scale) when the power of the fundamental is extrapolated to the converter's full-scale range.

DC Power Supply Rejection Ratio (DC PSRR)

The DC PSRR is the ratio of the change in offset error to a change in analog supply voltage. The DC PSRR is typically given in units of mV/V.

AC Power Supply Rejection Ratio (AC PSRR)

AC PSRR is the measure of rejection of variations in the supply voltage of the ADC. If ΔV_{SUP} is the change in the supply voltage and ΔV_{OUT} is the resultant change in the ADC output code (referred to the input), then

$$PSRR = 20\text{Log}^{10} \frac{\Delta V_{OUT}}{\Delta V_{SUP}} \quad (\text{Expressed in dBc}) \quad (7)$$

Common-Mode Rejection Ratio (CMRR)

CMRR is the measure of rejection of variations in the input common-mode voltage of the ADC. If ΔV_{cm} is the change in the input common-mode voltage and ΔV_{OUT} is the resultant change in the ADC output code (referred to the input), then

$$CMRR = 20\text{Log}^{10} \frac{\Delta V_{OUT}}{\Delta V_{CM}} \quad (\text{Expressed in dBc}) \quad (8)$$

Voltage Overload Recovery

The number of clock cycles taken to recover to less than 1% error for a 6-dB overload on the analog inputs. A 6-dBFS sine wave at Nyquist frequency is used as the test stimulus.

PACKAGING INFORMATION

Orderable Device	Status ⁽¹⁾	Package Type	Package Drawing	Pins	Package Qty	Eco Plan ⁽²⁾	Lead/Ball Finish	MSL Peak Temp ⁽³⁾	Samples (Requires Login)
ADS6142SKGD1	ACTIVE	XCEPT	KGD	0	80	TBD	Call TI	N / A for Pkg Type	

⁽¹⁾ The marketing status values are defined as follows:

ACTIVE: Product device recommended for new designs.

LIFEBUY: TI has announced that the device will be discontinued, and a lifetime-buy period is in effect.

NRND: Not recommended for new designs. Device is in production to support existing customers, but TI does not recommend using this part in a new design.

PREVIEW: Device has been announced but is not in production. Samples may or may not be available.

OBSOLETE: TI has discontinued the production of the device.

⁽²⁾ Eco Plan - The planned eco-friendly classification: Pb-Free (RoHS), Pb-Free (RoHS Exempt), or Green (RoHS & no Sb/Br) - please check <http://www.ti.com/productcontent> for the latest availability information and additional product content details.

TBD: The Pb-Free/Green conversion plan has not been defined.

Pb-Free (RoHS): TI's terms "Lead-Free" or "Pb-Free" mean semiconductor products that are compatible with the current RoHS requirements for all 6 substances, including the requirement that lead not exceed 0.1% by weight in homogeneous materials. Where designed to be soldered at high temperatures, TI Pb-Free products are suitable for use in specified lead-free processes.

Pb-Free (RoHS Exempt): This component has a RoHS exemption for either 1) lead-based flip-chip solder bumps used between the die and package, or 2) lead-based die adhesive used between the die and leadframe. The component is otherwise considered Pb-Free (RoHS compatible) as defined above.

Green (RoHS & no Sb/Br): TI defines "Green" to mean Pb-Free (RoHS compatible), and free of Bromine (Br) and Antimony (Sb) based flame retardants (Br or Sb do not exceed 0.1% by weight in homogeneous material)

⁽³⁾ MSL, Peak Temp. -- The Moisture Sensitivity Level rating according to the JEDEC industry standard classifications, and peak solder temperature.

Important Information and Disclaimer: The information provided on this page represents TI's knowledge and belief as of the date that it is provided. TI bases its knowledge and belief on information provided by third parties, and makes no representation or warranty as to the accuracy of such information. Efforts are underway to better integrate information from third parties. TI has taken and continues to take reasonable steps to provide representative and accurate information but may not have conducted destructive testing or chemical analysis on incoming materials and chemicals. TI and TI suppliers consider certain information to be proprietary, and thus CAS numbers and other limited information may not be available for release.

In no event shall TI's liability arising out of such information exceed the total purchase price of the TI part(s) at issue in this document sold by TI to Customer on an annual basis.

OTHER QUALIFIED VERSIONS OF ADS6142-HT :

- Catalog: [ADS6142](#)

NOTE: Qualified Version Definitions:

- Catalog - TI's standard catalog product

IMPORTANT NOTICE

Texas Instruments Incorporated and its subsidiaries (TI) reserve the right to make corrections, modifications, enhancements, improvements, and other changes to its products and services at any time and to discontinue any product or service without notice. Customers should obtain the latest relevant information before placing orders and should verify that such information is current and complete. All products are sold subject to TI's terms and conditions of sale supplied at the time of order acknowledgment.

TI warrants performance of its hardware products to the specifications applicable at the time of sale in accordance with TI's standard warranty. Testing and other quality control techniques are used to the extent TI deems necessary to support this warranty. Except where mandated by government requirements, testing of all parameters of each product is not necessarily performed.

TI assumes no liability for applications assistance or customer product design. Customers are responsible for their products and applications using TI components. To minimize the risks associated with customer products and applications, customers should provide adequate design and operating safeguards.

TI does not warrant or represent that any license, either express or implied, is granted under any TI patent right, copyright, mask work right, or other TI intellectual property right relating to any combination, machine, or process in which TI products or services are used. Information published by TI regarding third-party products or services does not constitute a license from TI to use such products or services or a warranty or endorsement thereof. Use of such information may require a license from a third party under the patents or other intellectual property of the third party, or a license from TI under the patents or other intellectual property of TI.

Reproduction of TI information in TI data books or data sheets is permissible only if reproduction is without alteration and is accompanied by all associated warranties, conditions, limitations, and notices. Reproduction of this information with alteration is an unfair and deceptive business practice. TI is not responsible or liable for such altered documentation. Information of third parties may be subject to additional restrictions.

Resale of TI products or services with statements different from or beyond the parameters stated by TI for that product or service voids all express and any implied warranties for the associated TI product or service and is an unfair and deceptive business practice. TI is not responsible or liable for any such statements.

TI products are not authorized for use in safety-critical applications (such as life support) where a failure of the TI product would reasonably be expected to cause severe personal injury or death, unless officers of the parties have executed an agreement specifically governing such use. Buyers represent that they have all necessary expertise in the safety and regulatory ramifications of their applications, and acknowledge and agree that they are solely responsible for all legal, regulatory and safety-related requirements concerning their products and any use of TI products in such safety-critical applications, notwithstanding any applications-related information or support that may be provided by TI. Further, Buyers must fully indemnify TI and its representatives against any damages arising out of the use of TI products in such safety-critical applications.

TI products are neither designed nor intended for use in military/aerospace applications or environments unless the TI products are specifically designated by TI as military-grade or "enhanced plastic." Only products designated by TI as military-grade meet military specifications. Buyers acknowledge and agree that any such use of TI products which TI has not designated as military-grade is solely at the Buyer's risk, and that they are solely responsible for compliance with all legal and regulatory requirements in connection with such use.

TI products are neither designed nor intended for use in automotive applications or environments unless the specific TI products are designated by TI as compliant with ISO/TS 16949 requirements. Buyers acknowledge and agree that, if they use any non-designated products in automotive applications, TI will not be responsible for any failure to meet such requirements.

Following are URLs where you can obtain information on other Texas Instruments products and application solutions:

Products

Audio	www.ti.com/audio
Amplifiers	amplifier.ti.com
Data Converters	dataconverter.ti.com
DLP® Products	www.dlp.com
DSP	dsp.ti.com
Clocks and Timers	www.ti.com/clocks
Interface	interface.ti.com
Logic	logic.ti.com
Power Mgmt	power.ti.com
Microcontrollers	microcontroller.ti.com
RFID	www.ti-rfid.com
OMAP Mobile Processors	www.ti.com/omap
Wireless Connectivity	www.ti.com/wirelessconnectivity

Applications

Automotive and Transportation	www.ti.com/automotive
Communications and Telecom	www.ti.com/communications
Computers and Peripherals	www.ti.com/computers
Consumer Electronics	www.ti.com/consumer-apps
Energy and Lighting	www.ti.com/energy
Industrial	www.ti.com/industrial
Medical	www.ti.com/medical
Security	www.ti.com/security
Space, Avionics and Defense	www.ti.com/space-avionics-defense
Video and Imaging	www.ti.com/video

TI E2E Community Home Page

e2e.ti.com

Mailing Address: Texas Instruments, Post Office Box 655303, Dallas, Texas 75265
Copyright © 2012, Texas Instruments Incorporated