

Surface Mount Transformers/Inductors, Gapped and Ungapped Custom Configurations Available

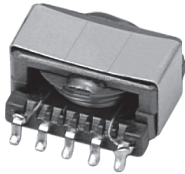

ELECTRICAL SPECIFICATIONS

(Multiple winds are connected in parallel)

Inductance Range: 10 μ H to 68000 μ H, measured at 0.10V RMS @ 10kHz without DC current, using an HP 4263A or HP 4284A impedance analyzer.

DC Resistance Range: 0.03 ohm to 24.1 ohm, measured at + 25°C \pm 5°C.

Rated Current Range: 2.29 amps to .07 amps.

Dielectric Withstanding Voltage: 500V RMS, 60Hz, 5 seconds.

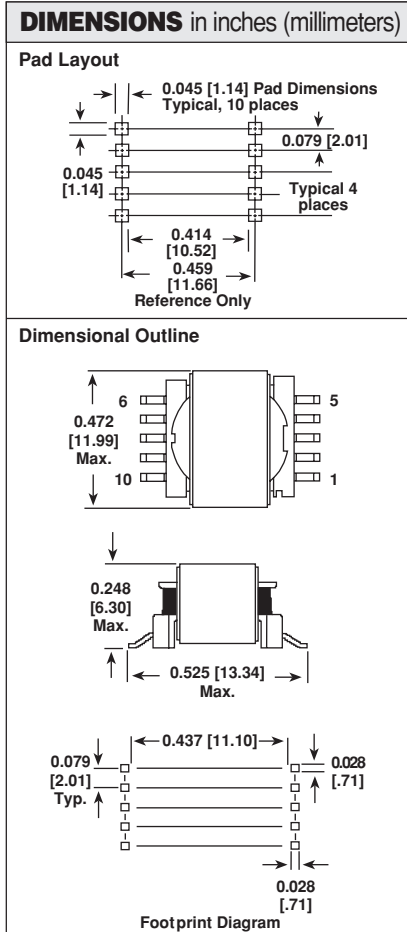

NOTE: Pad layout guidelines per MIL-STD-275E (printed wiring for electronic equipment). Tolerances: xx \pm 0.01" [\pm 0.25mm], xxx \pm 0.005" [\pm 0.12mm].

STANDARD ELECTRICAL SPECIFICATIONS						
MODEL	IND. (μ H)	IND. TOL.	SCHEMATIC LETTER	DCR MAX. (Ohms)	MAX. RATED* DC CURRENT (Amps)	SATURATING** CURRENT (Amps)
Ungapped Models						
LPE-5047-151NA	150	\pm 30%	A	0.20	0.79	N/A
LPE-5047-221NA	220	\pm 30%	A	0.24	0.72	N/A
LPE-5047-331NA	330	\pm 30%	A	0.29	0.65	N/A
LPE-5047-471NA	470	\pm 30%	A	0.35	0.59	N/A
LPE-5047-681NA	680	\pm 30%	A	0.42	0.54	N/A
LPE-5047-102NA	1000	\pm 30%	A	0.51	0.49	N/A
LPE-5047-152NA	1500	\pm 30%	A	0.63	0.44	N/A
LPE-5047-222NA	2200	\pm 30%	A	0.76	0.40	N/A
LPE-5047-332NA	3300	\pm 30%	A	1.00	0.35	N/A
LPE-5047-472NA	4700	\pm 30%	A	2.24	0.24	N/A
LPE-5047-682NA	6800	\pm 30%	A	2.70	0.21	N/A
LPE-5047-103NA	10000	\pm 30%	A	3.27	0.19	N/A
LPE-5047-153NA	15000	\pm 30%	A	6.26	0.14	N/A
LPE-5047-223NA	22000	\pm 30%	A	7.58	0.13	N/A
LPE-5047-333NA	33000	\pm 30%	A	9.50	0.11	N/A
LPE-5047-473NA	47000	\pm 30%	A	18.5	0.08	N/A
LPE-5047-683NA	68000	\pm 30%	A	24.1	0.07	N/A
Gapped Models						
LPE-5047-100MB	10	\pm 20%	B	0.03	2.29	2.690
LPE-5047-150MB	15	\pm 20%	B	0.04	2.07	2.230
LPE-5047-220MB	22	\pm 20%	B	0.05	1.68	1.860
LPE-5047-330MB	33	\pm 20%	C	0.09	1.35	1.540
LPE-5047-470MB	47	\pm 20%	D	0.13	1.11	1.300
LPE-5047-680MB	68	\pm 20%	D	0.15	1.01	1.085
LPE-5047-101MB	100	\pm 20%	D	0.24	0.81	0.900
LPE-5047-151MB	150	\pm 20%	D	0.37	0.65	0.740
LPE-5047-221MB	220	\pm 20%	E	0.55	0.53	0.610
LPE-5047-331MB	330	\pm 20%	E	0.85	0.43	0.500
LPE-5047-471MB	470	\pm 20%	E	1.29	0.35	0.420
LPE-5047-681MB	680	\pm 20%	E	1.96	0.28	0.350
LPE-5047-102MB	1000	\pm 20%	E	2.38	0.26	0.290
LPE-5047-152MB	1500	\pm 20%	E	3.66	0.21	0.240
LPE-5047-222MB	2200	\pm 20%	E	5.47	0.17	0.195
LPE-5047-332MB	3300	\pm 20%	E	8.48	0.14	0.160
LPE-5047-472MB	4700	\pm 20%	E	13.2	0.11	0.135

*DC current that will create a maximum temperature rise of 30°C when applied at + 25°C ambient. **DC current that will typically reduce the initial inductance by 20%.

UNGAPPED MODELS: Highest possible inductance with the lowest DCR and highest Q capability. Beneficial in filter, impedance matching and line coupling devices.

GAPPED MODELS: Capable of handling large amounts of DC current, tighter inductance tolerance with better temperature stability than ungapped models. Beneficial in DC to DC converters or other circuits carrying DC currents or requiring inductance stability over a temperature range.

DESCRIPTION - LPE-5047-102NA

LPE	5047	1000 μ H	\pm 30%	A
MODEL	SIZE	INDUCTANCE VALUE	INDUCTANCE TOLERANCE	CORE

SAP PART NUMBERING GUIDELINES (INTERNAL)

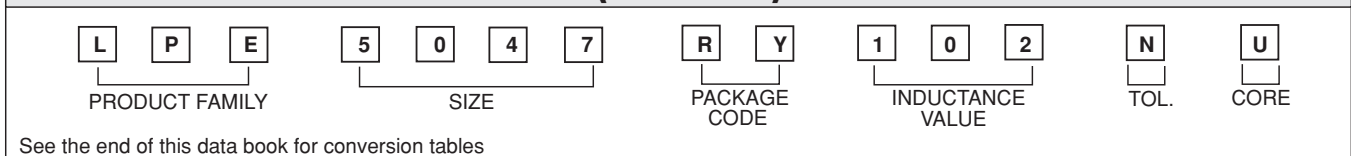

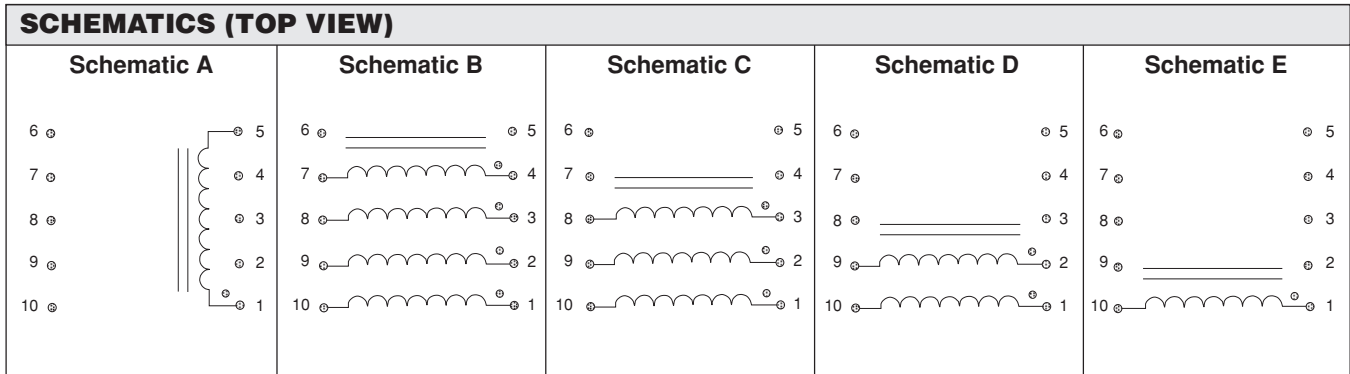

NOTE: Schematic A is for Ungapped LPE Series.

ENVIRONMENTAL PERFORMANCE	
TEST	CONDITIONS
Thermal Cycling	Withstands - 55°C to +125°C
Operating Temperature	- 55°C to + 125°C*
High Humidity	85%
Soldering Heat	Tested to + 230°C
Mechanical Shock	Per MIL-STD-202, Method 213 (100G)
Vibration	Per MIL-STD-202, Method 204 (20G)
Solderability	Per industry standards

*Must be checked in end use application

PART MARKING	
—	Vishay Dale
—	Date code
—	Marking code (Suffix of model #)
—	Pin 1 indicator

PACKAGING

TAPE SPECIFICATIONS:
Carrier Tape Type: Conductive.
Cover Tape Type: Anti-static.
Cover Tape Adhesion to Carrier: 40 ± 30 grams.

REEL SPECIFICATIONS:
Diameter (flange): 13" [330.2mm].
Maximum Width (over flanges): 1.197" [30.4mm].

STANDARDS: All embossed carrier tape packaging will be accomplished in compliance with latest revision of EIA-481 "Taping of Surface Mount Components for Automatic Placement".

MODEL	TAPE WIDTH	COMPONENT PITCH	UNITS PER 13 INCH REEL
LPE-5047	24mm	16mm	600

Tape and Reel Orientation

NOTE: Top view shown with cover tape removed.