

PDL06W SERIES

DC-DC CONVERTER

4:1 ULTRA WIDE INPUT RANGE
UP TO 6 Watts

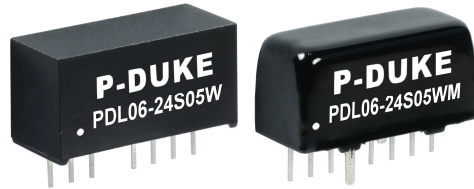

FEATURES

- NO MINIMUM LOAD REQUIRED
- UP TO 3000VDC INPUT TO OUTPUT ISOLATION
- SMALL SIZE AND LOW PROFILE : 0.86 X 0.36 X 0.44 INCH
- UL60950-1, EN60950-1, & IEC60950-1 SAFETY APPROVALS
- CE MARKED
- COMPLIANT TO RoHS II & REACH

APPLICATIONS

- WIRELESS NETWORK
- TELECOM/DATACOM
- INDUSTRY CONTROL SYSTEM
- DISTRIBUTED POWER ARCHITECTURES
- SEMICONDUCTOR EQUIPMENT

3000VDC ISOLATION	1600VDC ISOLATION	REMOTE CONTROL	OCP	SCP	LOW STANDBY POWER
-------------------	-------------------	----------------	-----	-----	-------------------

TECHNICAL SPECIFICATION

All specifications are typical at nominal input, full load and 25°C otherwise noted

Model Number	Input Range VDC	Output Voltage VDC	Output Current @Full Load mA	Input Current @ No Load mA	Efficiency %	Maximum Capacitor Load µF
PDL06-24S3P3W	9 ~ 36	3.3	1500	4	81	2200
PDL06-24S05W	9 ~ 36	5	1200	4	84	1100
PDL06-24S09W	9 ~ 36	9	666	4	86	680
PDL06-24S12W	9 ~ 36	12	500	4	87	470
PDL06-24S15W	9 ~ 36	15	400	4	88	470
PDL06-24S24W	9 ~ 36	24	250	4	87	180
PDL06-24D05W	9 ~ 36	±5	±600	6	84	±680
PDL06-24D12W	9 ~ 36	±12	±250	6	87	±330
PDL06-24D15W	9 ~ 36	±15	±200	8	87	±180
PDL06-48S3P3W	18 ~ 75	3.3	1500	4	81	2200
PDL06-48S05W	18 ~ 75	5	1200	4	84	1100
PDL06-48S09W	18 ~ 75	9	666	4	85	680
PDL06-48S12W	18 ~ 75	12	500	4	87	470
PDL06-48S15W	18 ~ 75	15	400	4	87	470
PDL06-48S24W	18 ~ 75	24	250	4	87	180
PDL06-48D05W	18 ~ 75	±5	±600	6	84	±680
PDL06-48D12W	18 ~ 75	±12	±250	6	87	±330
PDL06-48D15W	18 ~ 75	±15	±200	8	87	±180

PART NUMBER STRUCTURE

Series Name	Input Voltage (VDC)	Output Quantity	Output Voltage (VDC)	Input Range	Case & Isolation Option
PDL06 - 48 S 05 W H	24: 9~36 48: 18~75	S: Single	3P3: 3.3 05: 5 09: 9 12: 12 15: 15 24: 24	4 : 1	□: Standard type Plastic case 1600VDC isolation H: Plastic case 3000VDC isolation M: Metal case 1600VDC isolation
		D: Dual	05: ± 5 12: ±12 15: ±15		

INPUT SPECIFICATIONS

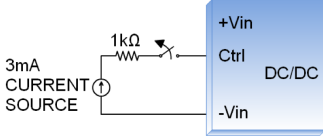
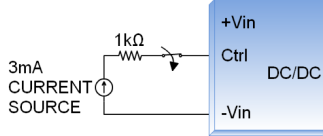
Parameter	Conditions	Min.	Typ.	Max.	Unit
Operating input voltage range	24Vin(nom) 48Vin(nom)	9 18	24 48	36 75	VDC
Start up time	Constant resistive load Power up Remote ON/OFF		30 30		ms
Input surge voltage	1 second, max. 24Vin(nom) 48Vin(nom)			50 100	VDC
Input reflected ripple current	24Vin(nom) 48Vin(nom)		20 40		mAp-p
Input filter					Capacitor type
Remote ON/OFF	Ctrl pin applied current via 1kΩ DC-DC ON DC-DC OFF Remote off input current	2	3	4 2.5	mA mA
<p>Application circuit</p> <p>DC-DC ON</p>  <p>DC-DC OFF</p> 					

OUTPUT SPECIFICATIONS

Parameter	Conditions	Min.	Typ.	Max.	Unit
Voltage accuracy		-1.0		+1.0	%
Line regulation	Low Line to High Line at Full Load	-0.2		+0.2	%
Load regulation	No Load to Full Load	-0.5		+0.5	%
Cross regulation	Asymmetrical load 25%/100% FL	-1.0		+1.0	%
Ripple and noise	20MHz bandwidth		50 75		mVp-p
Temperature coefficient		-0.02		+0.02	%/°C
Transient response recovery time	25% load step change		250		μs
Over load protection	% of Iout rated; Hiccup mode		180		%
Short circuit protection					Continuous, automatic recovery

GENERAL SPECIFICATIONS

Parameter	Conditions	Min.	Typ.	Max.	Unit
Isolation voltage	1 minute Input to Output Standard Type Suffix "H" Suffix "M" Input (Output) to Case Suffix "M"	1600 3000 1600 1000			VDC
Isolation resistance	500VDC	1			GΩ
Isolation capacitance	Standard Type Suffix "H" Suffix "M"		50 50 50		pF
Switching frequency		522	580	638	kHz
Safety approvals					UL60950-1 EN60950-1 IEC60950-1
Case material	Standard Type Suffix "H" Suffix "M"				Non-conductive black plastic Non-conductive black plastic Copper
Base material					None
Potting material					Silicone (UL94 V-0)
Weight	Standard Type Suffix "H" Suffix "M"				4.8g (0.17oz) 4.8g (0.17oz) 5.9g (0.21oz)
MTBF	MIL-HDBK-217F Standard Type Suffix "H" Suffix "M"				2.928 x 10 ⁶ hrs 2.928 x 10 ⁶ hrs 3.161 x 10 ⁶ hrs

ENVIRONMENTAL SPECIFICATIONS

Parameter	Conditions	Min.	Typ.	Max.	Unit
Operating ambient temperature	Standard type	-40		+100	°C
	Suffix "H"	-40		+100	
	Suffix "M"	-40		+100	
Storage temperature range		-55		+125	°C
Thermal shock					MIL-STD-810F
Vibration					MIL-STD-810F
Relative humidity					5% to 95% RH

EMC SPECIFICATIONS

Parameter	Conditions	Level
EMI ⁽¹⁾	EN55022	Class A , Class B
ESD	EN61000-4-2	Air ± 8kV and Contact ± 6kV
Radiated immunity	EN61000-4-3	20 V/m
Fast transient ⁽²⁾	EN61000-4-4	± 2kV
Surge ⁽²⁾	EN61000-4-5	±2kV
Conducted immunity	EN61000-4-6	10 Vr.m.s
Power frequency magnetic field	EN61000-4-8	100A/m continuous; 1000A/m 1 second

Note:

- The standard module meets either EMI Class A and Class B with external components. For further information, please contact with P-DUKE.
- An external input filter capacitor is required if the module has to meet EN61000-4-4, EN61000-4-5.

The filter Power Mate suggested:

The PDL06-24□□□W recommended an aluminum electrolytic capacitor (Nippon chemi-con KY series, 220µF/100V) and a TVS (SMDJ70A, 70V, 3000Watt peak pulse power) to connect in parallel.

The PDL06-48□□□W recommended an aluminum electrolytic capacitor (Nippon chemi-con KY series, 220µF/100V) and a TVS (SMDJ120A, 120V, 3000Watt peak pulse power) to connect in parallel.

CAUTION: This power module is not internally fused. An input line fuse must always be used.

CHARACTERISTIC CURVE

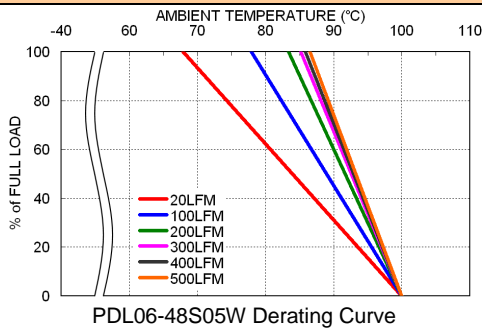

PDL06-48S05W Derating Curve

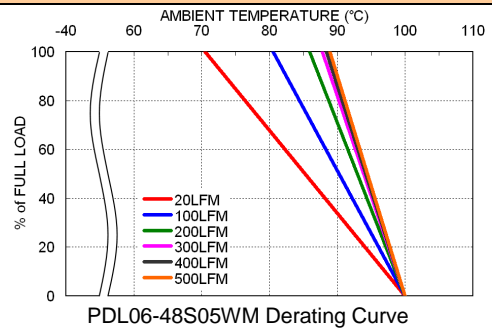

PDL06-48S05WM Derating Curve

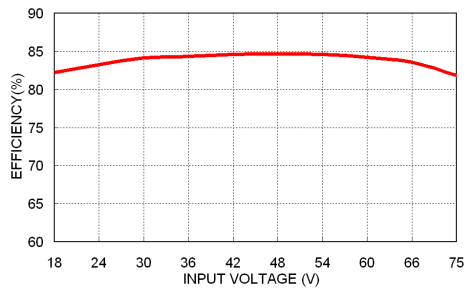

PDL06-48S05W Efficiency vs. Input Voltage

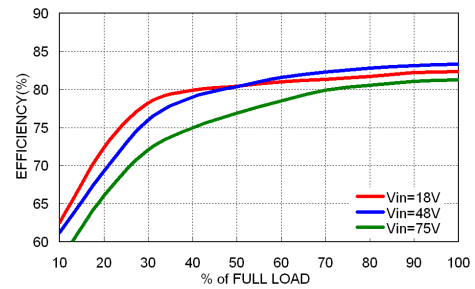

PDL06-48S05W Efficiency vs. Output Load

MECHANICAL DRAWING

Standard type, Suffix "H"

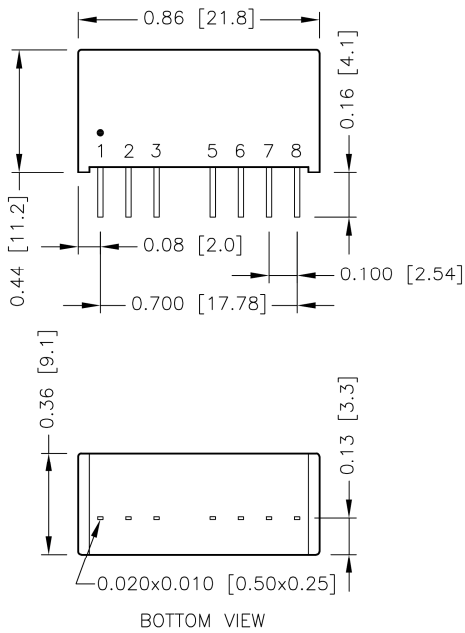

PIN CONNECTION

PIN	SINGLE	DUAL
1	-Vin	-Vin
2	+Vin	+Vin
3	Ctrl	Ctrl
5	NC*/No pin**	NC*/No pin**
6	+Vout	+Vout
7	-Vout	Common
8	NC	-Vout

*NC pin for standard type model.

**No pin for 3kVDC isolation model (suffix "H").

1. All dimensions in inch [mm]
2. Tolerance :x.xx±0.02 [x.x±0.5]
x.xxx±0.01 [x.xx±0.25]
3. Pin pitch tolerance ±0.01 [0.25]
4. Pin dimension tolerance ±0.004[0.1]

Suffix "M"

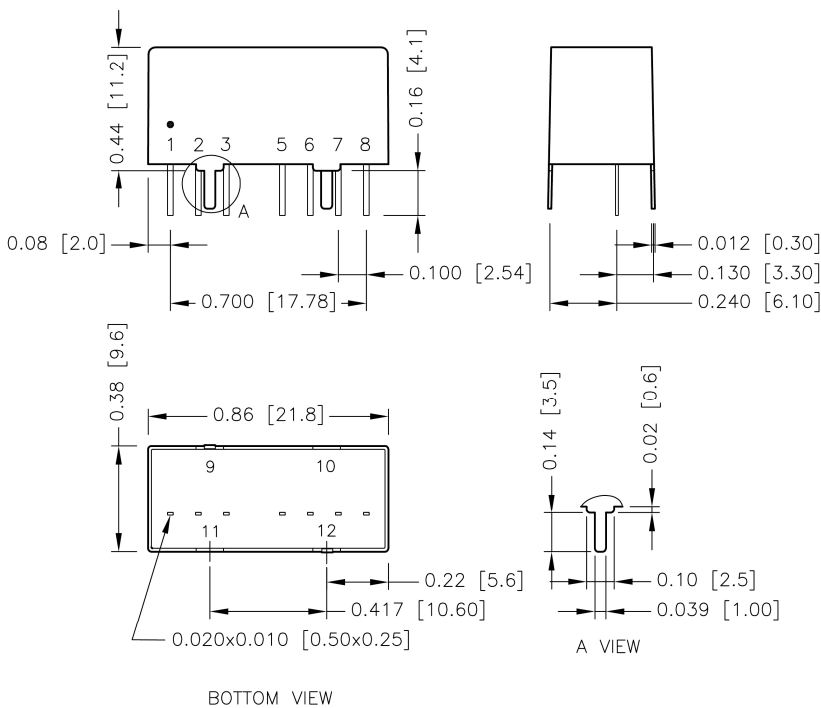

PIN CONNECTION

PIN	SINGLE	DUAL
1	-Vin	-Vin
2	+Vin	+Vin
3	Ctrl	Ctrl
5	NC	NC
6	+Vout	+Vout
7	-Vout	Common
8	NC	-Vout
9	Case	Case
10	Stand off	Stand off
11	Stand off	Stand off
12	Case	Case

1. All dimensions in inch [mm]
2. Tolerance :x.xx±0.02 [x.x±0.5]
x.xxx±0.01 [x.xx±0.25]
3. Pin pitch tolerance ±0.01 [0.25]
4. Pin dimension tolerance ±0.004 [0.1]