

**FB-25541-000**  
SHT 1.1

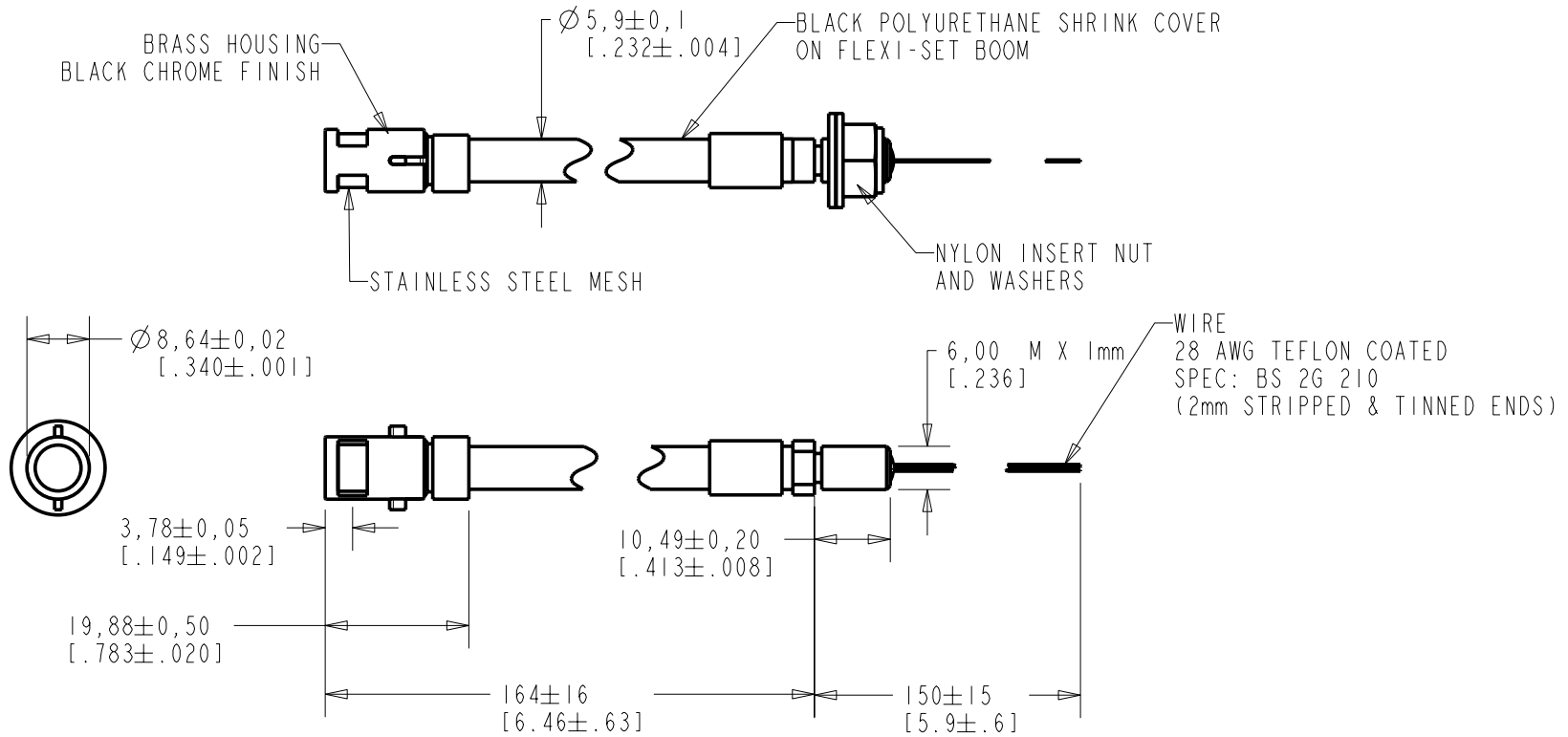

WIRE COLOR			WEIGHT GRAMS
+ve	-ve	SCREEN	
RED	BLACK	GREEN	29.1

DIMENSIONS IN MILLIMETERS [INCHES]

Revision	C.O. #	Implementation Date	RELEASE LEVEL	REVISION
B	CI0106598	2-26-08	<b>Active</b>	<b>B</b>
A	MI0101086	6-4-06		

SCALE: 1:1	DR. BY MMM	DATE 6-1-06
DO NOT SCALE DRAWING	CK. BY GJP	DATE 6-7-06
TITLE: <b>BOOM MICROPHONE</b> OUTLINE DRAWING	<b>FB-25541-000</b> SHT 1.1	APP. BY GJP
		DATE 6-7-06

**KNOWLES ELECTRONICS**  
ITASCA, ILLINOIS U.S.A.

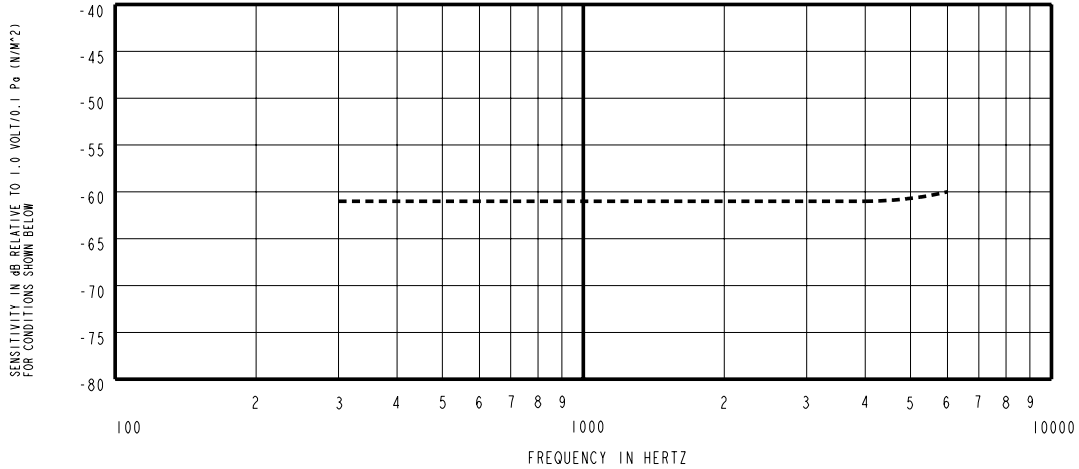

NOTES:

- MICROPHONE TO BE FUNCTIONAL WITH 10 VDC SUPPLY.
- SENSITIVITY VALUES INDICATED ON THIS SPECIFICATION ARE VALID AT 50% HUMIDITY.
- SENSITIVITY

FREQUENCY	MIN	NOM	MAX
300	-65.0	-61.0	-57.0
1000	-64.0	-61.0	-58.0
4000	-65.0	-61.0	-57.0
- TEST CONDITIONS:  
HEAD OF BOOM EXPOSED TO 94 dB SPL SWEPT SOUND FIELD AT 6mm FROM VOICE APERTURE.  
ARTIFICIAL VOICE: B & K 4227 MOUTH SIMULATOR.
- FOR MICROPHONE CAPSULE SPEC. SEE WP-23501-000 SHEET 2.1

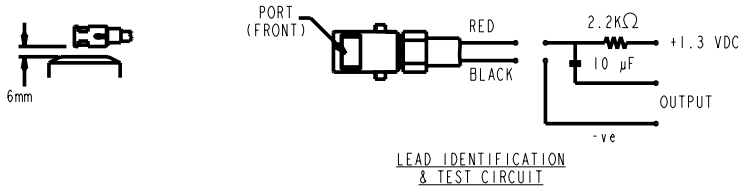

Revision	C.O. #	Implementation Date	RELEASE LEVEL	REVISION
B	C10106598	2-26-08	<b>Active</b>	<b>B</b>
A	M10101086	6-4-06		

**KNOWLES ELECTRONICS**  
ITASCA, ILLINOIS U.S.A.

WHEN TEST LIMITS ARE USED TO ESTABLISH INCOMING INSPECTION ACCEPTANCE/REJECTION CRITERIA, CORRELATION OF TEST EQUIPMENT WITH KNOWLES IS ALSO REQUIRED FOR ELIMINATION OF EQUIPMENT AND TEST METHOD VARIATION

TITLE: **BOOM MICROPHONE** **FB-25541-000**  
PERFORMANCE SPECIFICATION **SHT 2.1**

DR. BY	DATE
MMM	6-1-06
CK. BY	DATE
GJP	6-7-06
APP. BY	DATE
GJP	6-7-06