

Rev	AWO #	Description	Date	Appr
-		RELEASED	1/14/11	

APPROVED: _____
 DATE: _____ TITLE: _____

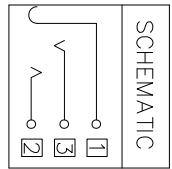
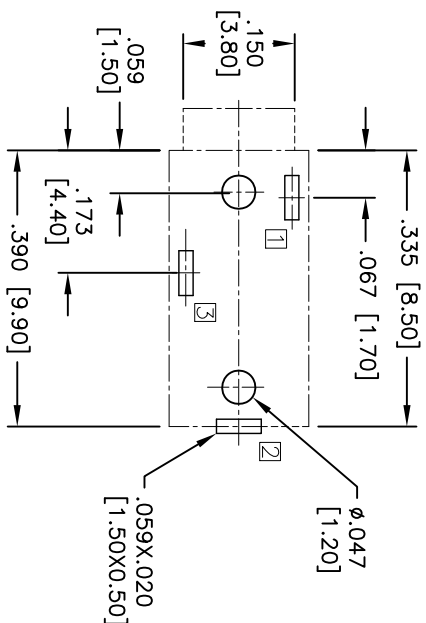
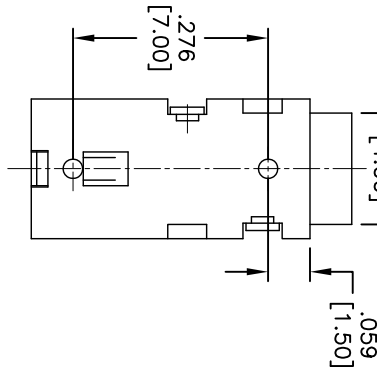
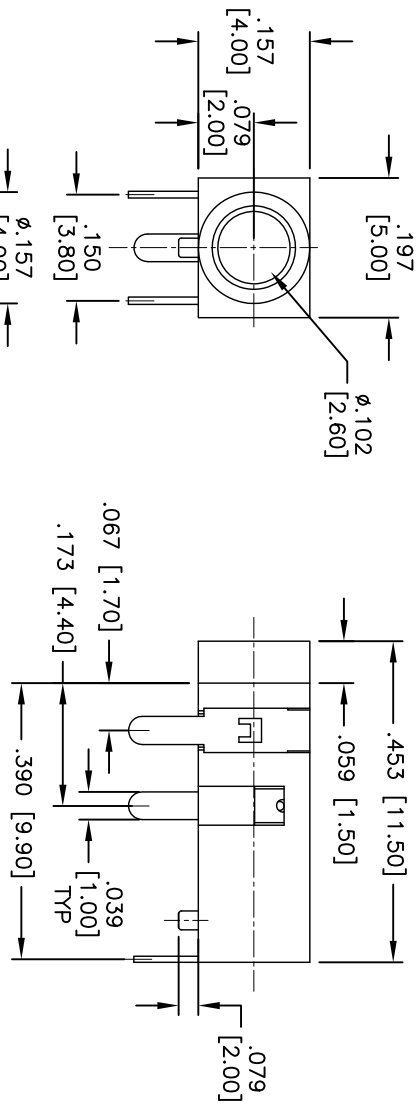

RECOMMENDED PCB LAYOUT
(COMPONENT SIDE)

SPECIFICATIONS:

- Material: Insulator: PA46, rated UL 94V-0
- Insulator color: Black
- Contacts: Phosphor Bronze
- Plating: Silver over Nickel underplate overall

- Electrical: Operating voltage: 30 VDC max.
- Current rating: 0.5 Amp max.
- Contact resistance: 30 mohms max. initial
- Insulation resistance: 100 Mohms min.
- Dielectric withstanding voltage: 500 VAC for 1 minute
- Temperature Rating: Operating temperature: -30°C to +70°C

- Environmental: Lead free, RoHS Compliant
- Recommended soldering temp. 235°C. for 5 sec.



ADAM TECH

909 Railway Avenue, Union, NJ 07083
 Phone: 908-687-5000 Fax: 908-687-5710

STEREO PHONE JACK, 2.5MM

UNLESS OTHERWISE SPECIFIED ALL DIMENSIONS ARE IN INCHES [MM] TOLERANCES ARE AS NOTED		TITLE	
INCHES .X ±.10 .XX ±.020 .XXX ±.015		STEREO PHONE JACK, 2.5MM	
HOLE SIZE ØX ±.10 ØXX ±.015 ØXXX ±.010		PART NO. ASL-135-3	
APPROVALS		SCALE: NTS	
DRAWN AY	DATE 1/14/11	SIZE X	SHEET 1 OF 1
CHECKED SC	DATE 1/14/11	REF: S0002C	REV.
APPROVED			