

## TPS53317 6-A Output, D-CAP+ Mode, Synchronous Step-Down, Integrated-FET Converter for DDR Memory Termination

### 1 Features

- TI proprietary Integrated MOSFET and Packaging Technology
- Supports DDR Memory Termination with up to 6-A Continuous Output Source or Sink Current
- External Tracking
- Minimum External Components Count
- 1-V to 6-V Conversion Voltage
- D-CAP+™ Mode Architecture
- Supports All MLCC Output Capacitors and SP/POSCAP
- Selectable SKIP Mode or Forced CCM
- Optimized Efficiency at Light and Heavy Loads
- Selectable 600-kHz or 1-MHz Switching Frequency
- Selectable Overcurrent Limit (OCL)
- Overvoltage, Over-Temperature and Hiccup Undervoltage Protection
- Adjustable Output Voltage from 0.6 V to 2 V
- 3.5 mm × 4 mm, 20-Pin VQFN Package

### 2 Applications

- Memory Termination Regulator for DDR, DDR2, DDR3, DDR3L, and DDR4
- VTT Termination
- Low-Voltage Applications for 1-V to 6-V Input Rails

### 3 Description

The TPS53317 device is a FET-integrated synchronous buck regulator designed mainly for DDR termination. It can provide a regulated output at  $\frac{1}{2} V_{DDQ}$  with both sink and source capability. The TPS53317 device employs D-CAP+™ mode operation that provides ease of use, low external component count and fast transient response. The device can also be used for other point-of-load (POL) regulation applications requiring up to 6 A. In addition, the device supports full, 6-A, output sinking current capability with tight voltage regulation.

The device features two switching frequency settings (600 kHz and 1 MHz), integrated droop support, external tracking capability, pre-bias startup, output soft discharge, integrated bootstrap switch, power good function, V5IN pin UVLO protection, and supports both ceramic and SP/POSCAP capacitors. It supports input voltages up to 6.0 V, and output voltages adjustable from 0.6 V to 2.0 V.

The TPS53317 device is available in the 3.5 mm × 4 mm, 20-pin, VQFN package (Green RoHS compliant and Pb free) with TI proprietary Integrated MOSFET and packaging technology and is specified from –40°C to 85°C.

#### Device Information<sup>(1)</sup>

PART NUMBER	PACKAGE	BODY SIZE (NOM)
TPS53317	VQFN (20)	3.50 mm × 4.00 mm

(1) For all available packages, see the orderable addendum at the end of the data sheet.

#### Simplified Application

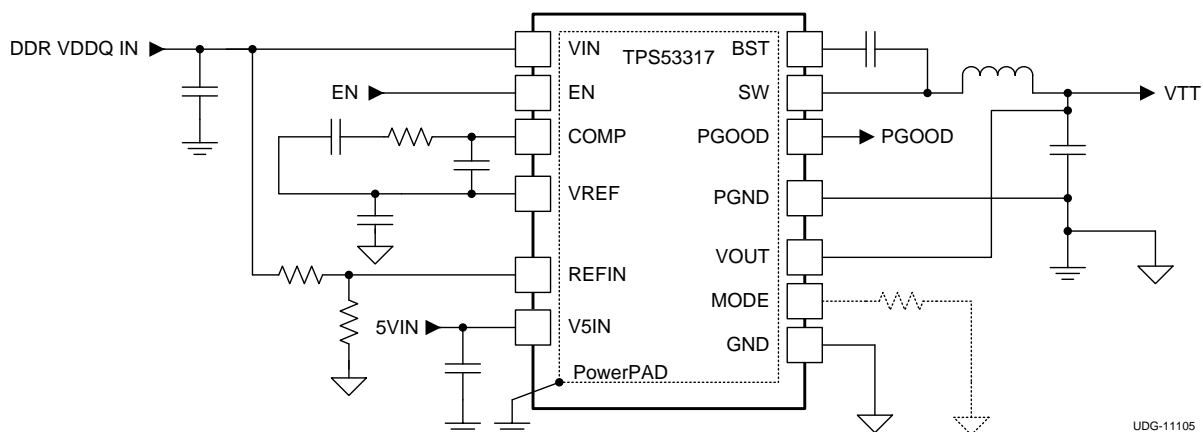

UDG-11105



## Table of Contents

<b>1 Features</b> .....	<b>1</b>	7.3 Feature Description .....	<b>12</b>
<b>2 Applications</b> .....	<b>1</b>	7.4 Device Functional Modes .....	<b>16</b>
<b>3 Description</b> .....	<b>1</b>	<b>8 Application and Implementation</b> .....	<b>20</b>
<b>4 Revision History</b> .....	<b>2</b>	8.1 Application Information .....	<b>20</b>
<b>5 Pin Configuration and Functions</b> .....	<b>4</b>	8.2 Typical Applications .....	<b>20</b>
<b>6 Specifications</b> .....	<b>5</b>	<b>9 Power Supply Recommendations</b> .....	<b>26</b>
6.1 Absolute Maximum Ratings .....	<b>5</b>	<b>10 Layout</b> .....	<b>26</b>
6.2 ESD Ratings .....	<b>5</b>	10.1 Layout Guidelines .....	<b>26</b>
6.3 Recommended Operating Conditions .....	<b>5</b>	10.2 Layout Example .....	<b>26</b>
6.4 Thermal Information .....	<b>6</b>	<b>11 Device and Documentation Support</b> .....	<b>27</b>
6.5 Electrical Characteristics .....	<b>6</b>	11.1 Community Resources .....	<b>27</b>
6.6 Typical Characteristics .....	<b>8</b>	11.2 Trademarks .....	<b>27</b>
<b>7 Detailed Description</b> .....	<b>11</b>	11.3 Electrostatic Discharge Caution .....	<b>27</b>
7.1 Overview .....	<b>11</b>	11.4 Glossary .....	<b>27</b>
7.2 Functional Block Diagram .....	<b>11</b>	<b>12 Mechanical, Packaging, and Orderable Information</b> .....	<b>27</b>

## 4 Revision History

NOTE: Page numbers for previous revisions may differ from page numbers in the current version.

Changes from Revision C (November 2013) to Revision D	Page
• Added <i>Pin Configuration and Functions</i> section, <i>ESD Rating</i> table, <i>Feature Description</i> section, <i>Device Functional Modes</i> , <i>Application and Implementation</i> section, <i>Power Supply Recommendations</i> section, <i>Layout</i> section, <i>Device and Documentation Support</i> section, and <i>Mechanical, Packaging, and Orderable Information</i> section .....	<b>1</b>
• Added "SW (transient 20 ns and E = 5 μJ)" specification in <a href="#">Absolute Maximum Ratings</a> table .....	<b>5</b>
• Added <a href="#">Figure 41</a> .....	<b>26</b>

Changes from Revision B (MAY 2012) to Revision C	Page
• Added clarity to <a href="#">Pin Configuration and Functions</a> table .....	<b>4</b>
• Added clarity to Internal soft-start delay time and soft-start time test conditions in Electrical Characteristics table .....	<b>7</b>
• Added <a href="#">Figure 17</a> , <a href="#">Figure 19</a> and <a href="#">Figure 20</a> in <a href="#">Power Sequences</a> section .....	<b>13</b>
• Added clarity to <a href="#">Output Overvoltage Protection (OVP)</a> section .....	<b>15</b>
• Changed minimum valley OCL from "is 6 A or 4 A" to "is 7.6 A or 5.4 A" in <a href="#">Overcurrent Limit</a> section .....	<b>15</b>
• Changed "the absolute value of the negative OCL set point is typically -6.5 A or -4.5 A" to "the typical value of the negative OCL set point is -9.3 A or -6.5 A" in <a href="#">Negative OCL</a> section .....	<b>16</b>
• Added clarity to <a href="#">Layout Guidelines</a> section .....	<b>26</b>

Changes from Revision A (JULY 2011) to Revision B	Page
• Added Memory Termination bullet in APPLICATIONS .....	<b>1</b>
• Added clarity to .....	<b>1</b>
• Added updates to <a href="#">Table 1</a> .....	<b>19</b>

---

**Changes from Original (JUNE 2011) to Revision A****Page**

- 
- Changed from "SKIP and Forced CCM" to "SKIP or Forced CCM" in FEATURES..... 1
  - Changed from "600-kHz and 1-MHz Switching" to "600-kHz or 1-MHz Switching" in FEATURES ..... 1
  - Added clarity to Simplified Application drawing..... 1
  - Changed from " $f_{SW} = 600 \text{ kHz}$ " to " $f_{SW} = 1 \text{ MHz}$ " for  $t_{ON(min)}$  in EC table ..... 7
-

## 5 Pin Configuration and Functions

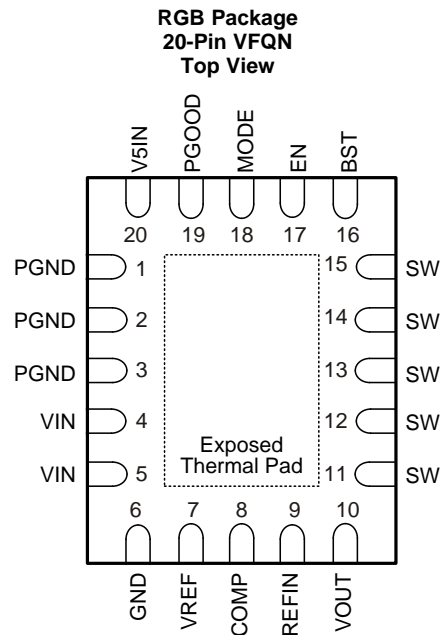

**Pin Functions**

PIN		I/O <sup>(1)</sup>	DESCRIPTION
NAME	NO.		
BST	16	I	Power supply for internal high-side gate driver. Connect a 0.1- $\mu$ F bootstrap capacitor between this pin and the SW pin. A series boot resistor is optional.
COMP	8	O	Connect an R-C-C network between this pin and VREF for loop compensation.
EN	17	I	Enable pin (3.3-V logic compatible).
GND	6	–	Analog ground.
MODE	18	I	Allows selection of different operation modes. (See <a href="#">Table 1</a> )
PGND	1	G	Power ground.
	2		
	3		
PGOOD	19	O	Open drain power good output. Connect pullup resistor.
REFIN	9	I	External tracking reference input. Apply voltage between 0.6 V to 2.0 V. For non-tracking mode, connect REFIN to VREF via resistor divider.
SW	11	I/O	Switching node output.
	12		
	13		
	14		
	15		
V5IN	20	I	5-V power supply for analog circuits and gate drive.
VIN	4	I	Power supply input pin.
	5		
VOUT	10	I	Output voltage monitor input pin.
VREF	7	O	2.0-V reference output. Connect a 0.22- $\mu$ F ceramic capacitor to GND.

(1) I = Input, O = Output, G = Ground

## 6 Specifications

### 6.1 Absolute Maximum Ratings

over operating free-air temperature range (unless otherwise noted) <sup>(1)</sup>

		MIN	MAX	UNIT
Input voltage range	BST (with respect to SW), V5IN, VIN	-0.3	7	V
	BST	-0.3	14	
	EN	-0.3	7	
	MODE, REFIN	-0.3	3.6	
	VOUT	-1	3.6	
Output voltage range	SW	-2	7	V
	SW (transient 20 ns and E = 5 $\mu$ J)	-3		
	COMP, VREF	-0.3	3.6	
	PGOOD	-0.3	7	
	PGND	-0.3	0.3	
Operating junction temperature, T <sub>J</sub>		-40	150	°C
Lead temperature 1,6 mm (1/16 inch) from case for 10 seconds			300	°C
Storage temperature, T <sub>stg</sub>		-55	150	°C

- (1) Stresses beyond those listed under *Absolute Maximum Ratings* may cause permanent damage to the device. These are stress ratings only, which do not imply functional operation of the device at these or any other conditions beyond those indicated under *Recommended Operating Conditions*. Exposure to absolute-maximum-rated conditions for extended periods may affect device reliability.

### 6.2 ESD Ratings

			VALUE	UNIT
V <sub>(ESD)</sub>	Electrostatic discharge	Human-body model (HBM), per ANSI/ESDA/JEDEC JS-001 <sup>(1)</sup>	$\pm 2000$	V
		Charged-device model (CDM), per JEDEC specification JESD22-C101 <sup>(2)</sup>	$\pm 500$	

- (1) JEDEC document JEP155 states that 500-V HBM allows safe manufacturing with a standard ESD control process. Manufacturing with less than 500-V HBM is possible with the necessary precautions. Pins listed as  $\pm 2000$  V may actually have higher performance.
- (2) JEDEC document JEP157 states that 250-V CDM allows safe manufacturing with a standard ESD control process. Manufacturing with less than 250-V CDM is possible with the necessary precautions. Pins listed as  $\pm 500$  V may actually have higher performance.

### 6.3 Recommended Operating Conditions

over operating free-air temperature range (unless otherwise noted)

		MIN	NOM	MAX	UNIT
Input voltage range	BST (with respect to SW), EN, VIN	-0.1		6.5	V
	V5IN	4.5		6.5	
	BST	-0.1		13.5	
	SW	-1.0		6.5	
	VOUT, MODE, REFIN	-0.1		3.5	
Output voltage range	COMP	-0.1		3.5	V
	VREF		2		
	PGOOD	-0.1		6.5	
	PGND	-0.1		0.1	
Operating temperature range, T <sub>A</sub>		-40		85	°C

## 6.4 Thermal Information

THERMAL METRIC <sup>(1)</sup>		TPS53317	UNIT
		RGB (VQFN)	
		20 PINS	
R <sub>θJA</sub>	Junction-to-ambient thermal resistance	35.5	°C/W
R <sub>θJC(top)</sub>	Junction-to-case (top) thermal resistance	39.6	°C/W
R <sub>θJB</sub>	Junction-to-board thermal resistance	12.4	°C/W
ψ <sub>JT</sub>	Junction-to-top characterization parameter	0.5	°C/W
ψ <sub>JB</sub>	Junction-to-board characterization parameter	12.5	°C/W
R <sub>θJC(bot)</sub>	Junction-to-case (bottom) thermal resistance	3.7	°C/W

(1) For more information about traditional and new thermal metrics, see the *Semiconductor and IC Package Thermal Metrics* application report, [SPRA953](#).

## 6.5 Electrical Characteristics

over recommended free-air temperature range, V<sub>V5IN</sub> = 5.0 V, PGND = GND (unless otherwise noted)

PARAMETER	TEST CONDITIONS	MIN	TYP	MAX	UNIT	
<b>SUPPLY: VOLTAGE, CURRENTS AND 5 V UVLO</b>						
I <sub>VINSD</sub>	VIN shutdown current	EN = 'LO'	0.02	5	μA	
V <sub>V5IN</sub>	V5IN supply voltage	V5IN voltage range	4.5	5.0	6.5	V
I <sub>V5IN</sub>	V5IN supply current	EN = 'HI', V5IN supply current, f <sub>SW</sub> = 600 kHz	1.1	2	mA	
I <sub>V5INSD</sub>	V5IN shutdown current	EN = 'LO', V5IN shutdown current	0.2	7.0	μA	
V <sub>V5UVLO</sub>	V5IN UVLO	Ramp up; EN = 'HI'	4.20	4.37	4.50	V
V <sub>V5UVHYS</sub>	V5IN UVLO hysteresis	Falling hysteresis	440		mV	
V <sub>VREFUVLO</sub>	REF UVLO <sup>(1)</sup>	Rising edge of VREF, EN = 'HI'	1.8		V	
V <sub>VREFUVHYS</sub>	REF UVLO hysteresis <sup>(1)</sup>		100		mV	
V <sub>POR5VFILT</sub>	Reset	OVP latch is reset by V5IN falling below the reset threshold	1.5	2.3	3.1	V
<b>VOLTAGE FEEDBACK LOOP: VREF, VOUT, AND VOLTAGE GM AMPLIFIER</b>						
V <sub>OUTTOL</sub>	Output voltage accuracy	V <sub>REFIN</sub> = 1 V, No droop	-1%	0%	1%	
		V <sub>REFIN</sub> = 0.6 V, No droop	-1%	0%	1%	
V <sub>VREF</sub>	VREF	I <sub>VREF</sub> = 0 μA	1.98	2.00	2.02	V
		I <sub>VREF</sub> = 50 μA	1.975	2.000	2.025	
I <sub>REFSNK</sub>	VREF sink current	V <sub>VREF</sub> = 2.05 V	2.5		mA	
g <sub>M</sub>	Transconductance		1.00		mS	
V <sub>CM</sub>	Common mode input voltage range <sup>(1)</sup>		0	2	V	
V <sub>DM</sub>	Differential mode input voltage		0	80	mV	
I <sub>COMPSNK</sub>	COMP pin maximum sinking current	V <sub>COMP</sub> = 2 V, (V <sub>REFIN</sub> - V <sub>OUT</sub> ) = 80 mV	80		μA	
I <sub>COMPSRC</sub>	COMP pin maximum sourcing current	V <sub>COMP</sub> = 2 V	-80		μA	
V <sub>OFFSET</sub>	Input offset voltage	T <sub>A</sub> = 25°C	0		mV	
R <sub>DSCH</sub>	Output voltage discharge resistance		42		Ω	
f <sub>-3dBVL</sub>	-3dB Frequency <sup>(1)</sup>		4.5	6.0	7.5	MHz
<b>CURRENT SENSE: CURRENT SENSE AMPLIFIER, OVERCURRENT AND ZERO CROSSING</b>						
A <sub>CSINT</sub>	Internal current sense gain	Gain from the current of the low-side FET to PWM comparator when PWM = "OFF"	43	53	57	mV/A
I <sub>OCL</sub>	Positive overcurrent limit (valley)		7.6		A	
I <sub>OCL(neg)</sub>	Negative overcurrent limit (valley)		-9.3		A	
V <sub>ZXOFF</sub>	Zero crossing comp internal offset		0		mV	

(1) Ensured by design, not production tested.

## Electrical Characteristics (continued)

over recommended free-air temperature range,  $V_{V5IN} = 5.0\text{ V}$ , PGND = GND (unless otherwise noted)

PARAMETER		TEST CONDITIONS	MIN	TYP	MAX	UNIT
<b>PROTECTION: OVP, UVP, PGOOD, and THERMAL SHUTDOWN</b>						
$V_{PGDLL}$	PGOOD deassert to lower (PGOOD → Low)	Measured at the VOUT pin wrt/ $V_{REFIN}$		84%		
$V_{PGHYSHL}$	PGOOD high hysteresis			8%		
$V_{PGDLH}$	PGOOD de-assert to higher (PGOOD → Low)	Measured at the VOUT pin wrt/ $V_{REFIN}$		116%		
$V_{PGHYSHH}$	PGOOD high hysteresis			-8%		
$V_{INMINPG}$	Minimum VIN voltage for valid PGOOD	Measured at the VIN pin with a 2- mA sink current on PGOOD pin. V5IN is grounded here. <sup>(2)</sup>	0.9	1.3	1.5	V
$V_{OVP}$	OVP threshold	Measured at the VOUT pin wrt/ $V_{REFIN}$	117%	120%	123%	
$V_{UVP}$	UVP threshold	Measured at the VOUT pin wrt/ $V_{REFIN}$ , device latches OFF, begins soft-stop	65%	68%	71%	
$TH_{SD}$	Thermal shutdown <sup>(1)</sup>	Latch off controller, attempt soft- stop.		145		°C
$TH_{SD(hys)}$	Thermal Shutdown hysteresis <sup>(1)</sup>	Controller re-starts after temperature has dropped		10		°C
<b>DRIVERS: BOOT STRAP SWITCH</b>						
$R_{DSONBST}$	Internal BST switch on-resistance	$I_{BST} = 10\text{ mA}$ , $T_A = 25^\circ\text{C}$			10	$\Omega$
$I_{BSTLK}$	Internal BST switch leakage current	$V_{BST} = 14\text{ V}$ , $V_{SW} = 7\text{ V}$			1	$\mu\text{A}$
<b>TIMERS: ON-TIME, MINIMUM OFF-TIME, SS, AND I/O TIMINGS</b>						
$t_{ONESHOTC}$	PWM one-shot <sup>(1)</sup>	$V_{VIN} = 5\text{ V}$ , $V_{VOUT} = 1.05\text{ V}$ , $f_{SW} = 1\text{ MHz}$		210		ns
		$V_{VIN} = 5\text{ V}$ , $V_{VOUT} = 1.05\text{ V}$ , $f_{SW} = 600\text{ kHz}$		310		
$t_{MIN(off)}$	Minimum OFF time	$V_{VIN} = 5\text{ V}$ , $V_{VOUT} = 1.05\text{ V}$ , $f_{SW} = 1\text{ MHz}$ , DRVL on, SW = PGND, $V_{VOUT} < V_{REFIN}$		270		ns
$t_{INT(SS)}$	Soft-start time	From $V_{OUT}$ ramp starting to $V_{OUT}$ =95%, default setting		1.6		ms
$t_{INT(SSDLY)}$	Internal soft-start delay time	From $V_{VREF} = 2\text{ V}$ to $V_{OUT}$ is ready to ramp up		260		$\mu\text{s}$
$t_{PGDPLY}$	PGOOD startup delay time	At external tracking, the time from $V_{OUT}$ is ready to ramp up		8		ms
$t_{PGDPDLYH}$	PGOOD high propagation delay time	50 mV over drive, rising edge	0.8	1	1.2	ms
$t_{PGDPDLYL}$	PGOOD low propagation delay time	50 mV over drive, falling edge		10		$\mu\text{s}$
$t_{OVPDLY}$	OVP delay time	Time from the VOUT pin out of +20% of $V_{REFIN}$ to OVP fault		10		$\mu\text{s}$
$t_{UVDLYEN}$	Undervoltage fault enable delay	Time from EN_INT going high to undervoltage fault is ready		2		ms
		External tracking from VOUT ramp starts		8		
$t_{UVPDLY}$	UVP delay time	Time from the VOUT pin out of -32% of $V_{REFIN}$ to UVP fault		256		$\mu\text{s}$
<b>LOGIC PINS: I/O VOLTAGE AND CURRENT</b>						
$V_{PGDPD}$	PGOOD pull-down voltage	PGOOD low impedance, $I_{SINK} = 4\text{ mA}$ , $V_{V5IN} = 4.5\text{ V}$			0.3	V
$I_{PGDLKG}$	PGOOD leakage current	PGOOD high impedance, forced to 5.5 V	-1	0	1	$\mu\text{A}$
$V_{ENH}$	EN logic high	EN, VCCP logic	2			V
$V_{ENL}$	EN logic low	EN, VCCP logic			0.5	V
$I_{EN}$	EN input current				1	$\mu\text{A}$

(2) If V5IN is higher than 1.5 V, PGOOD is valid regardless of the voltage applied at VIN. This is based on bench testing.

## Electrical Characteristics (continued)

over recommended free-air temperature range,  $V_{VIN} = 5.0\text{ V}$ , PGND = GND (unless otherwise noted)

PARAMETER	TEST CONDITIONS	MIN	TYP	MAX	UNIT
$V_{MODETH}$	Threshold 1	80	130	180	mV
	Threshold 2	200	250	300	
	Threshold 3	370	420	470	
	Threshold 4	1.765	1.800	1.850	V
$I_{MODE}$	MODE current		15		$\mu\text{A}$

(3) See Table 1 for descriptions of MODE parameters.

## 6.6 Typical Characteristics

Characterization data tested using the TPS53317EVM-750 where the external tracking input sets the output voltage and operates in non-droop mode. See SLUU642 for detailed configuration.

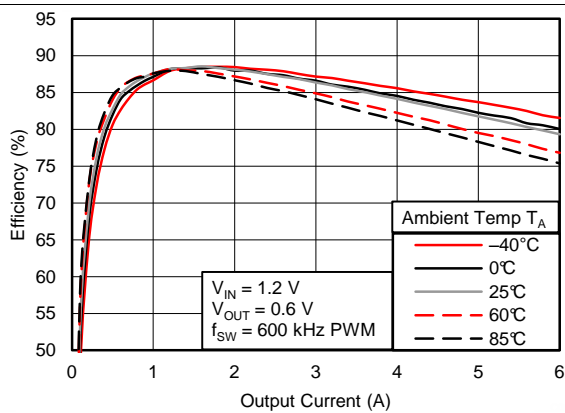

Figure 1. Efficiency vs. Output Current

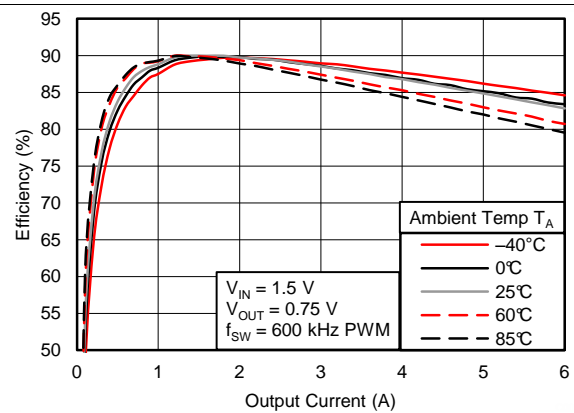

Figure 2. Efficiency vs. Output Current

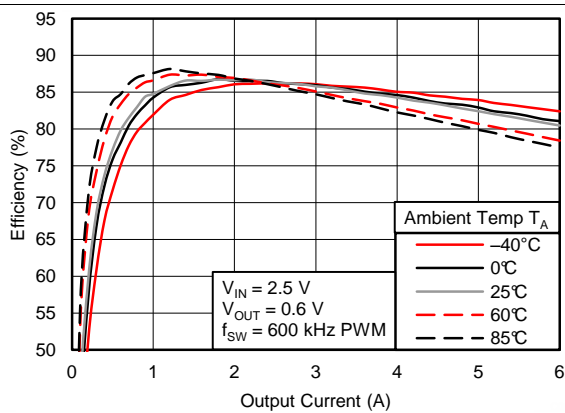

Figure 3. Efficiency vs. Output Current

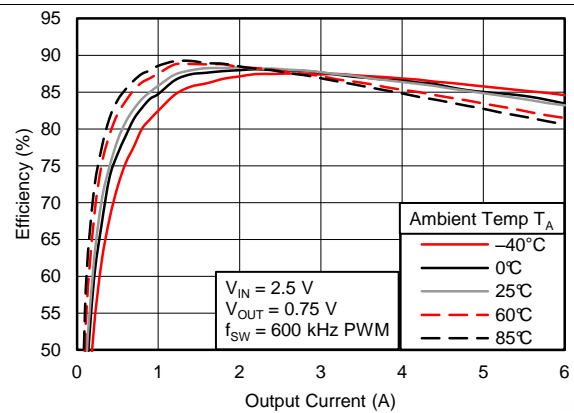
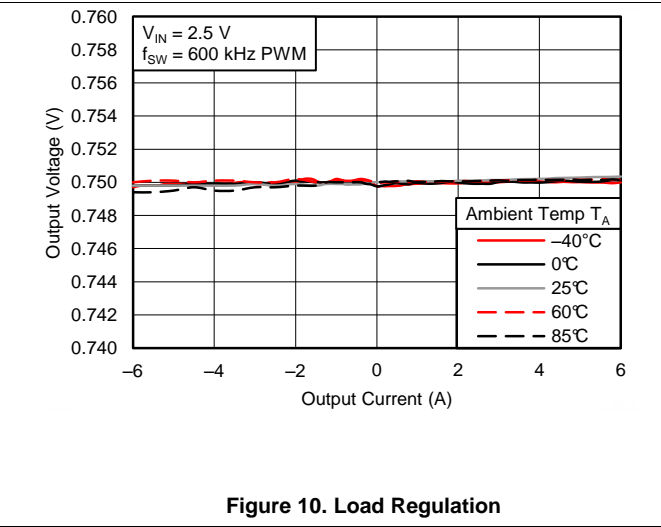
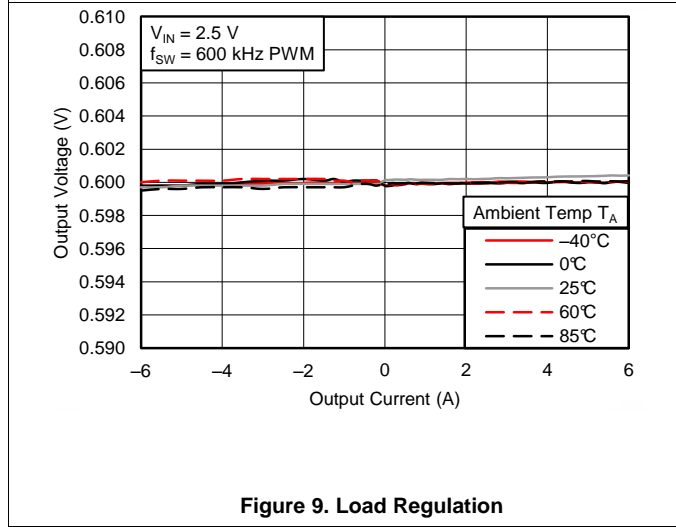
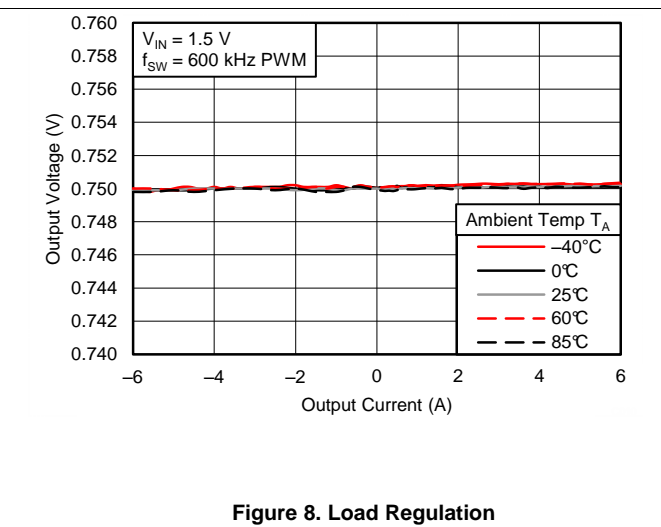
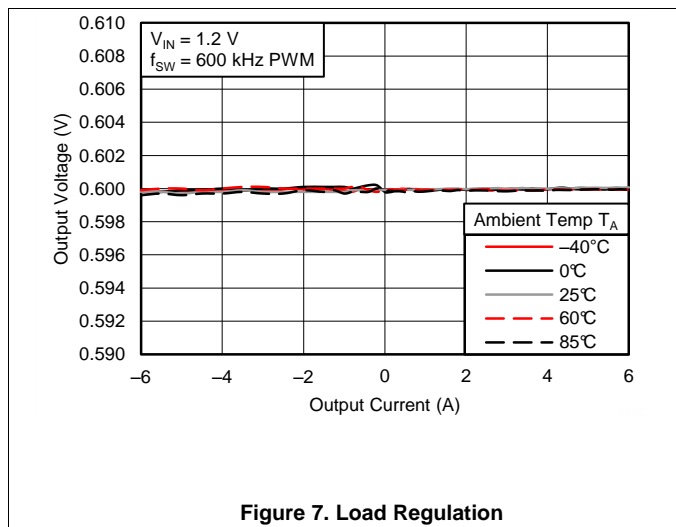
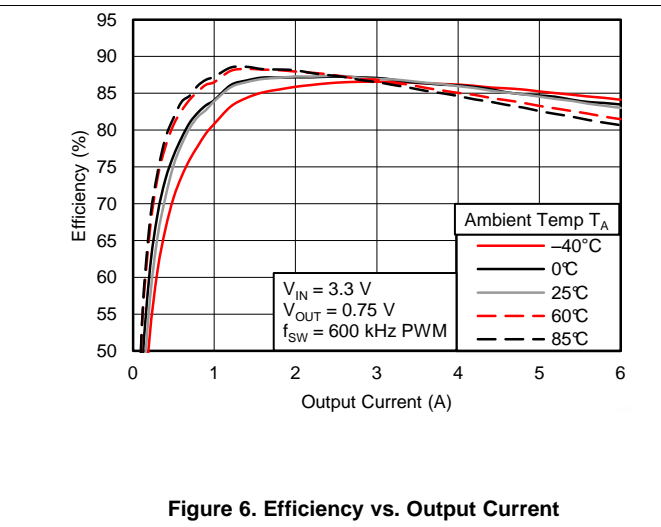
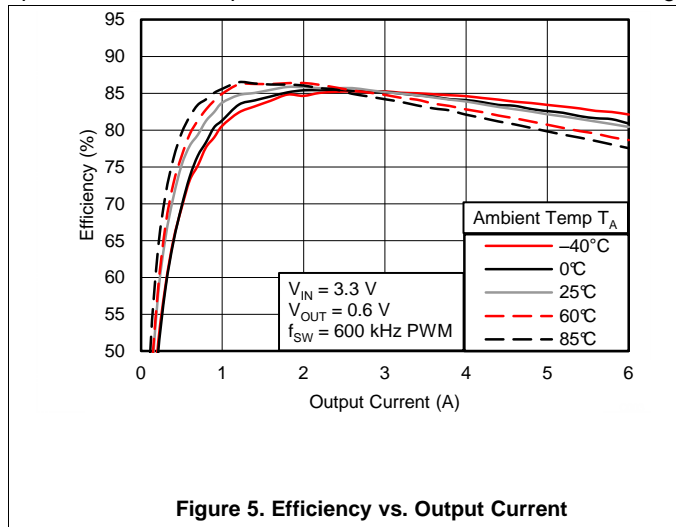

Figure 4. Efficiency vs. Output Current

### Typical Characteristics (continued)

Characterization data tested using the TPS53317EVM-750 where the external tracking input sets the output voltage and operates in non-droop mode. See [SLUU642](#) for detailed configuration.



### Typical Characteristics (continued)

Characterization data tested using the TPS53317EVM-750 where the external tracking input sets the output voltage and operates in non-droop mode. See [SLUU642](#) for detailed configuration.

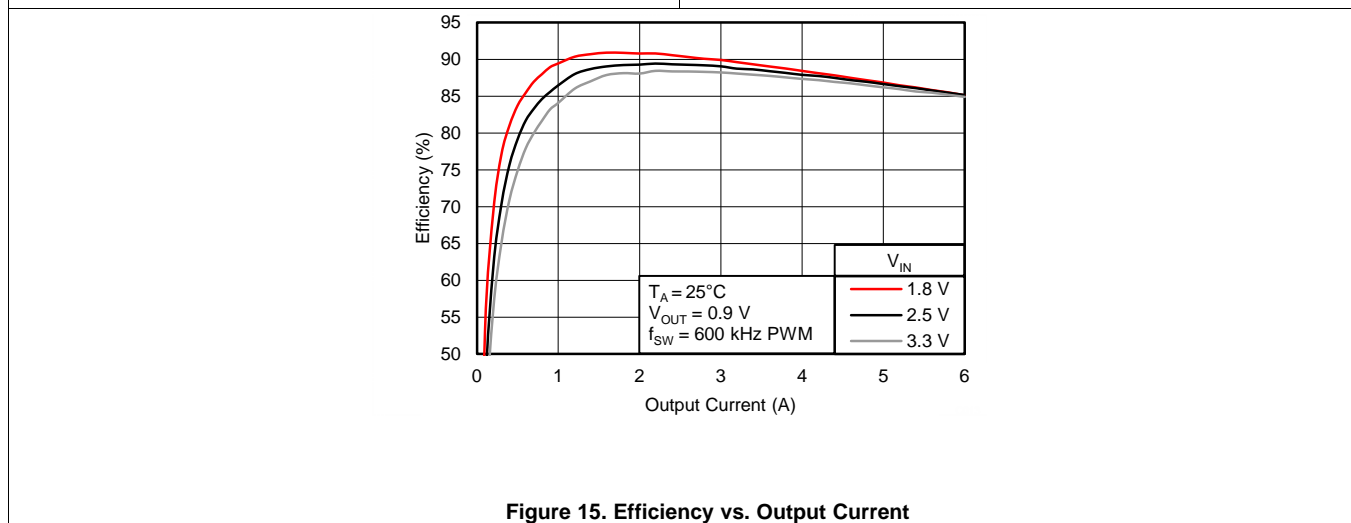
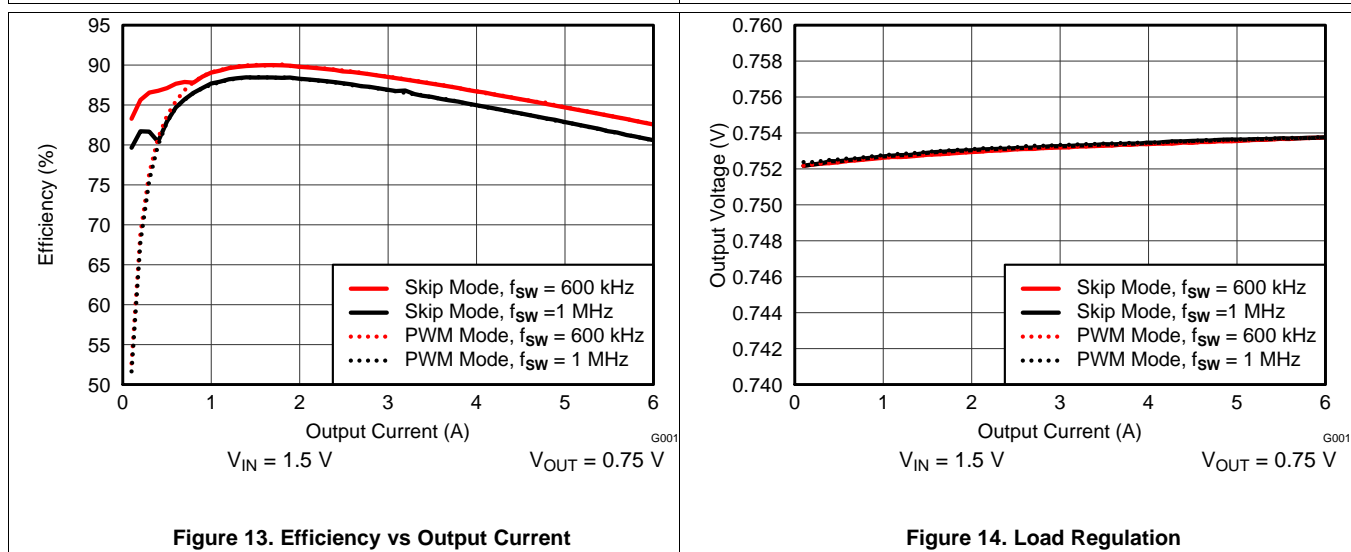
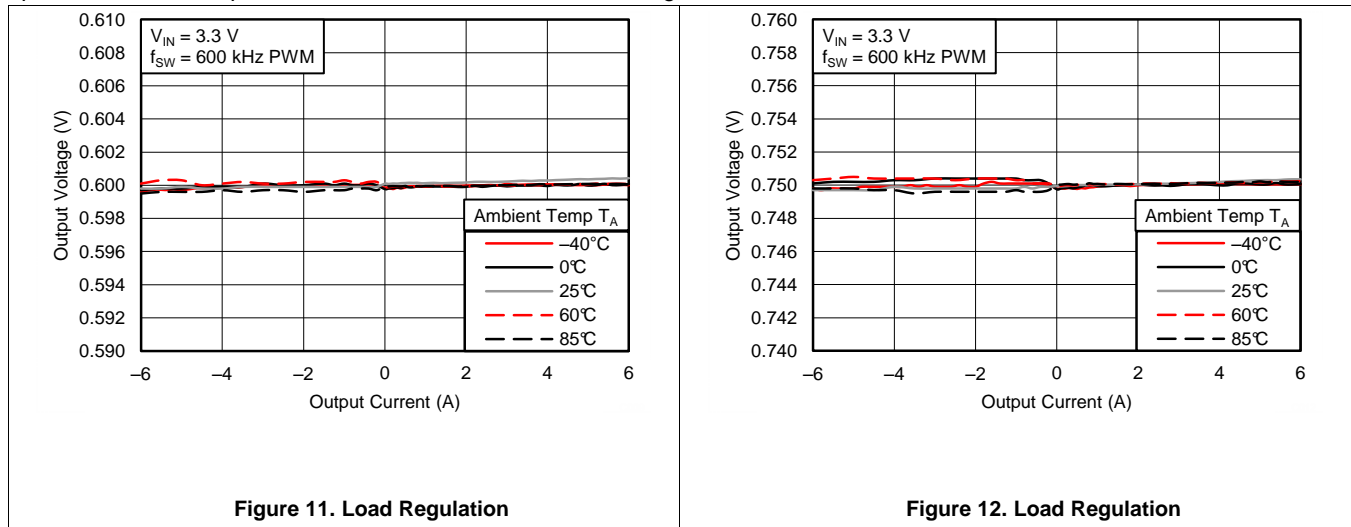

## 7 Detailed Description

### 7.1 Overview

The TPS53317 device is a D-CAP+™ mode adaptive on-time converter. Integrated high-side and low-side FETs support a maximum of 6-A DC output current. The converter automatically operates in discontinuous conduction mode (DCM) to optimize light-load efficiency. Multiple switching frequencies are provided to enable optimization of the power train for the cost, size and efficiency requirements of the design (see Table 1).

In adaptive on-time converters, the controller varies the on-time as a function of input and output voltage to maintain a nearly constant frequency during steady-state conditions. In conventional constant on-time converters, each cycle begins when the output voltage crosses to a fixed reference level. However, in the TPS53317 device, the cycle begins when the current feedback reaches an error voltage level which is the amplified difference between the reference voltage and the feedback voltage.

### 7.2 Functional Block Diagram

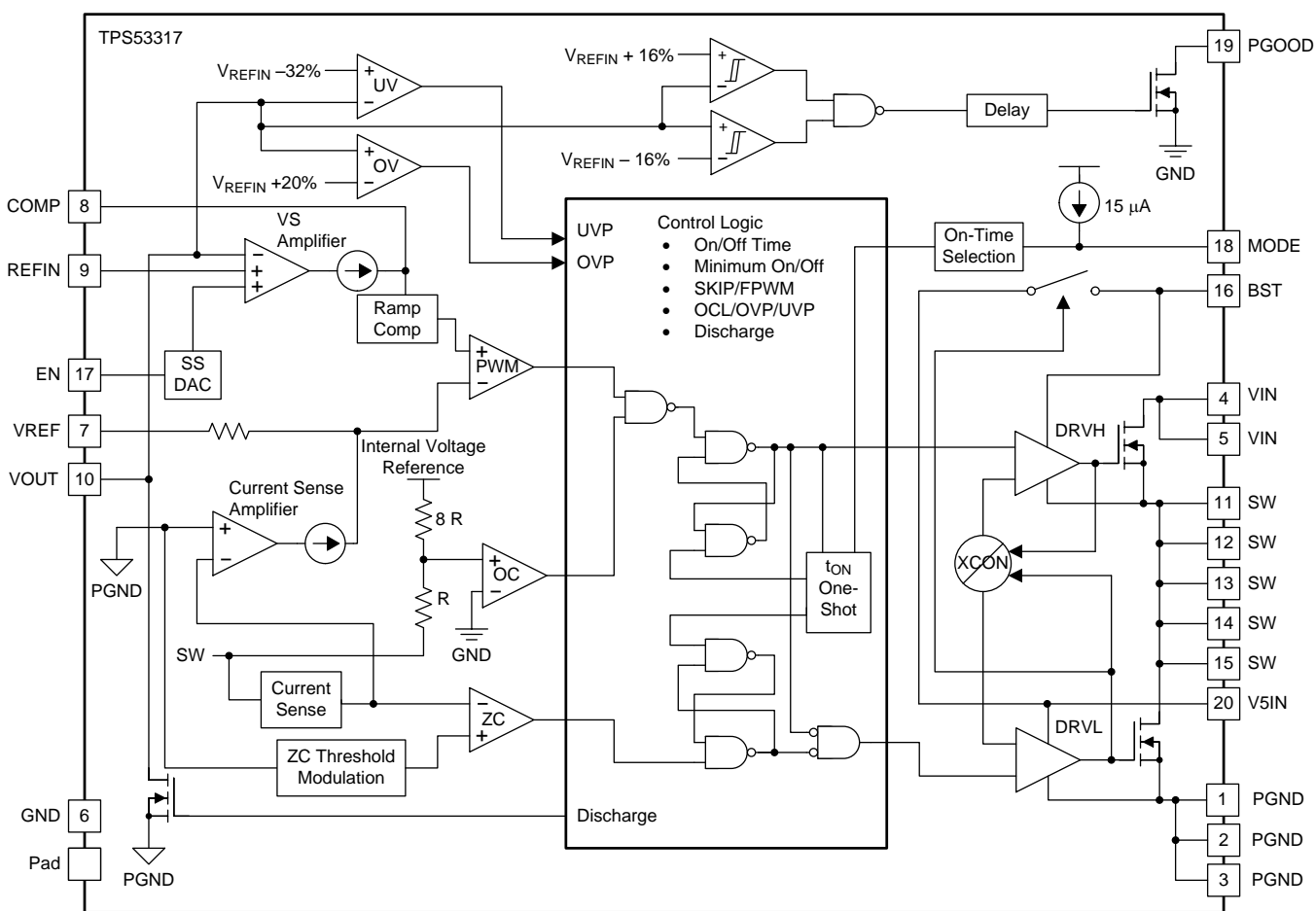

UDG-11106

## 7.3 Feature Description

### 7.3.1 PWM Operation

Referring to [Figure 16](#), in steady state, continuous conduction mode, the converter operates in the following way.

Starting with the condition that the top FET is off and the bottom FET is on, the current feedback ( $V_{CS}$ ) is higher than the error amplifier output ( $V_{COMP}$ ).  $V_{CS}$  falls until it hits  $V_{COMP}$ , which contains a component of the output ripple voltage.  $V_{CS}$  is not directly accessible by measuring signals on pins of TPS53317 device. The PWM comparator senses where the two waveforms cross and triggers the on-time generator.

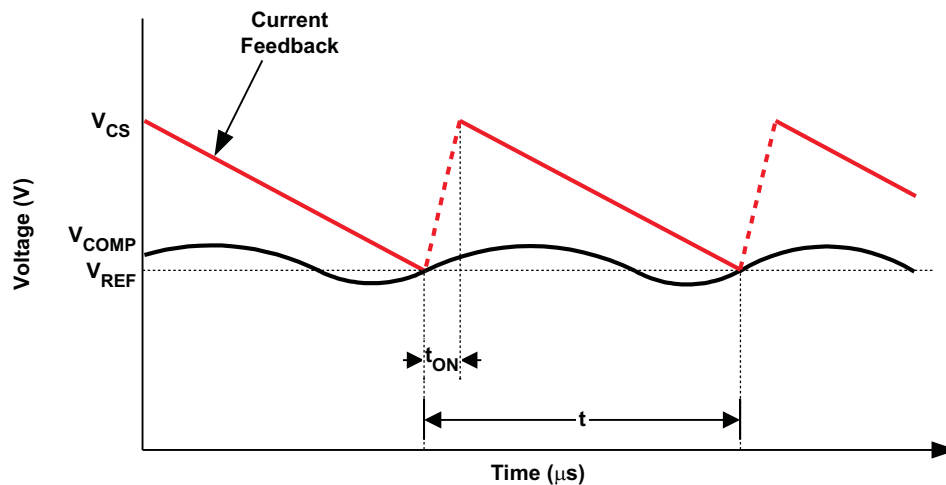

UDG-10187

**Figure 16. D-CAP+™ Mode Basic Waveforms**

The current feedback is an amplified and filtered version of the voltage between PGND and SW during low-side FET on-time. The device also provides a single-ended differential voltage ( $V_{OUT}$ ) feedback to increase the system accuracy and reduce the dependence of circuit performance on layout.

### 7.3.2 PWM Frequency and Adaptive On-Time Control

In general, the on-time (at the SW node) can be estimated by [Equation 1](#).

$$t_{ON} = \frac{V_{OUT}}{V_{IN}} \times \frac{1}{f_{SW}}$$

where

- $f_{SW}$  is the frequency selected by the connection of the MODE pin (1)

The on-time pulse is sent to the top FET. The inductor current and the current feedback rises to peak value. Each ON pulse is latched to prevent double pulsing. Switching frequency settings are shown in [Table 1](#).

### 7.3.3 Light-Load Power Saving Features

The TPS53317 device has an automatic pulse-skipping mode to provide excellent efficiency over a wide load range. The converter senses inductor current and prevents negative flow by shutting off the low-side gate driver. This saves power by eliminating re-circulation of the inductor current. Further, when the bottom FET shuts off, the converter enters discontinuous mode, and the switching frequency decreases, thus reducing switching losses as well.

The device also provides a special light-load power saving feature, called ripple reduction. Essentially, it reduces the on-time in SKIP mode to effectively reduce the output voltage ripple associated with using an all MLCC capacitor output power stage design.

## Feature Description (continued)

### 7.3.4 Power Sequences

#### 7.3.4.1 Non-Tracking Startup

The TPS53317 device can be configured for non-tracking application. When non-tracking is configured, output voltage is regulated to the REFIN voltage which taps off the voltage dividers from the 2-V reference voltage. Either the EN pin or the V5IN pin can be used to start up the device. The device uses internal voltage servo DAC to provide a 1.6-ms soft-start time during soft-start initialization. (See [Figure 18](#).)

In a non-tracking application, the output voltage is determined by the resistive divider between the VREF pin and the REFIN pin.

$$V_{OUT} = V_{REF} \times \frac{R2}{R1 + R2} \tag{2}$$

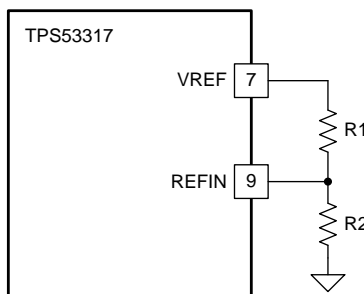

Figure 17. Non-Tracking Configuration

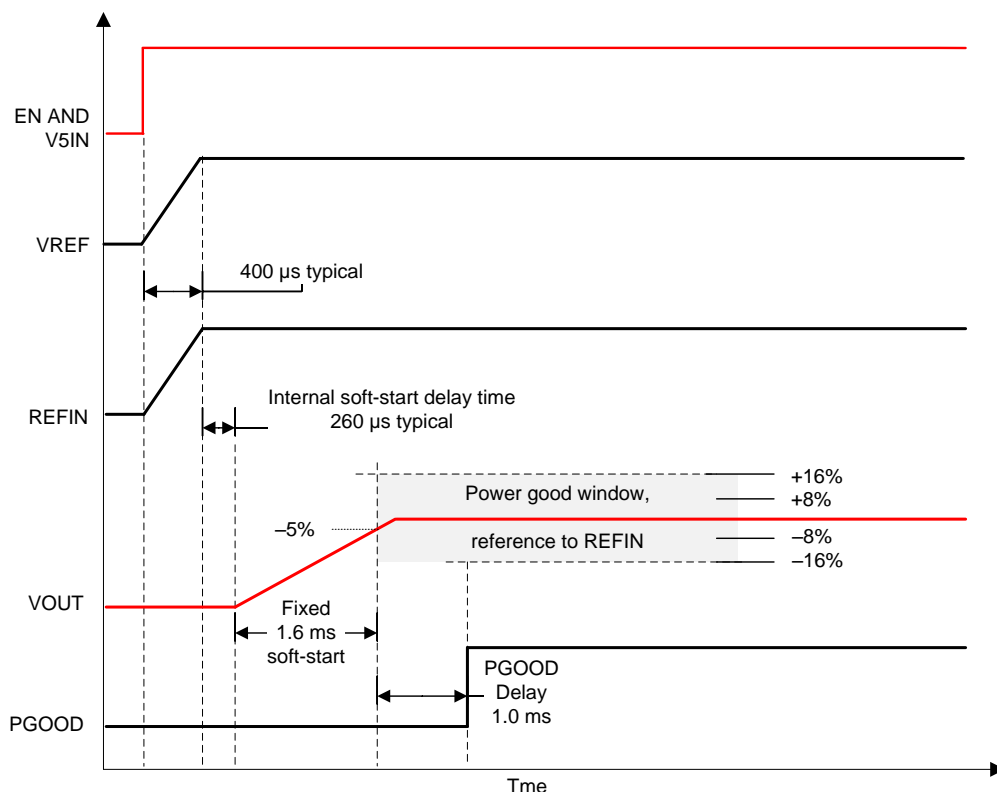

Figure 18. Non-Tracking Startup Timing

**Feature Description (continued)**

**7.3.4.2 Tracking Startup**

The TPS53317 device can also be configured for tracking application. When tracking configuration is desired, output voltage is also regulated to the REFIN voltage which comes from an external power source. In order for the device to differentiate between a non-tracking configuration or a tracking configuration, there is a minimum delay time of 260  $\mu$ s required between the time when VREF reaches 2 V to the time when the REFIN pin voltage can be applied, in order for the device to track properly (see Figure 21). The valid REFIN voltage range is between 0.6 V and 2 V.

In a tracking application, the output voltage should be one half of the VDDQ voltage. VDDQ can be VIN or it can be an additional voltage rail. Thus, R1= R2 both in Figure 19 and Figure 20.

$$V_{OUT} = \frac{1}{2} \times V_{VDDQ} \tag{3}$$

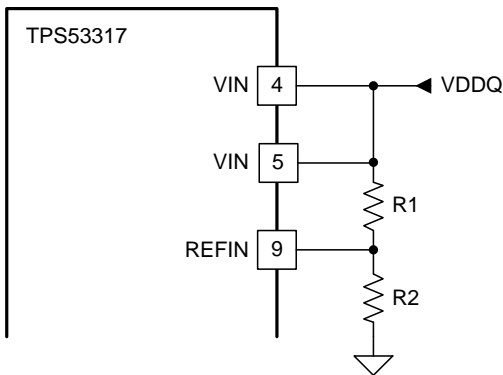

**Figure 19. Tracking Configuration 1**

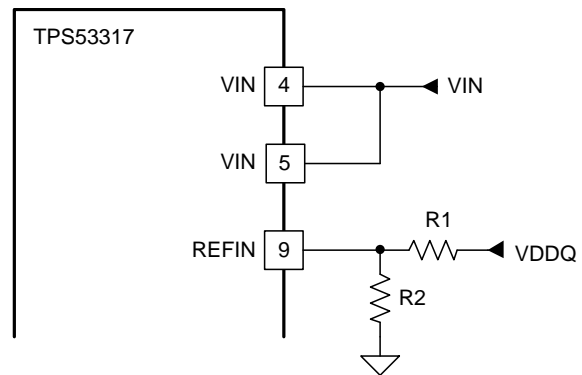

**Figure 20. Tracking Configuration 2**

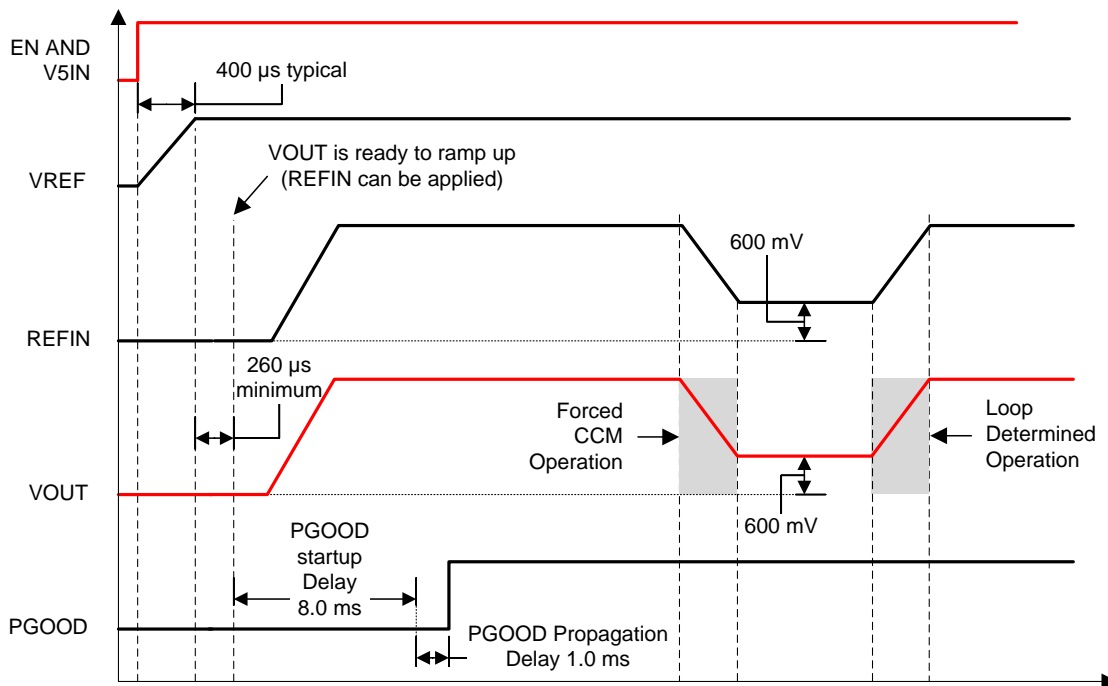

**Figure 21. Tracking Startup Timing**

Select PWM mode for an application that requires external tracking, because the output voltage can not be decreased during a no-load condition when the device operates in SKIP mode.

## Feature Description (continued)

### 7.3.5 Protection Features

The TPS53317 device offers many features to protect the converter power train as well as the system electronics.

#### 7.3.5.1 5-V Undervoltage Protection (UVLO)

The TPS53317 device continuously monitors the voltage on the V5IN pin to ensure that the voltage level is high enough to bias the device properly and to provide sufficient gate drive potential to maintain high efficiency. The converter starts with approximately 4.3 V and has a nominal 440 mV of hysteresis. If the 5-V UVLO limit is reached, the converter transitions the phase node into an off function, and the converter remains in the off state until the device is reset by cycling the 5-V supply until the 5-V POR is reached (2.3-V nominal). The power input does not have a UVLO function.

#### 7.3.5.2 Power Good Signals

The TPS53317 device has one open-drain *power good* (PGOOD) pin. During startup, there is a 1-ms power good high propagation delay. The PGOOD pin de-asserts as soon as the EN pin is pulled low or an undervoltage condition on V5IN or any other fault is detected.

#### 7.3.5.3 Output Overvoltage Protection (OVP)

In addition to the power good function described above, the TPS53317 device has additional OVP and UVP thresholds and protection circuits.

An OVP condition is detected when the output voltage is approximately  $120\% \times V_{REFIN}$ . In this case, the converter de-asserts the PGOOD signals and performs the overvoltage protection function. During OVP, the low-side FET is always on before triggering a negative overcurrent. When a negative OC is also tripped, the low-side FET is no longer continuously on, and pulsed signals are generated to limit the negative inductor current. When the VOUT pin voltage drops below 400 mV, the low-side FET turns off and the converter latches off. The converter remains in the off state until the device is reset by cycling the 5-V supply until the 5-V POR is reached (2.3-V nominal) or when the EN pin is toggled off and on.

#### 7.3.5.4 Output Undervoltage Protection (UVP)

Output undervoltage protection works in conjunction with the current protection described in the [Overcurrent Protection](#) and [Overcurrent Limit](#) sections. If the output voltage drops below 68% of  $V_{REFIN}$ , after approximately a 250- $\mu$ s delay, the device stops switching and enters hiccup mode. After a hiccup waiting time, a restart is attempted. If the fault condition is not cleared, hiccup mode operation may continue indefinitely.

#### 7.3.5.5 Overcurrent Protection

Both positive and negative overcurrent protection are provided in the TPS53317 device.

- Overcurrent Limit (OCL)
- Negative OCL

##### 7.3.5.5.1 Overcurrent Limit

If the sensed current value is above the OCL setting, the converter delays the next ON pulse until the current drops below the OCL limit. Current limiting occurs on a pulse-by-pulse basis. The device uses a valley current limiting scheme where the DC OCL trip point is the OCL limit plus half of the inductor ripple current. The typical valley OCL threshold is 7.6 A or 5.4 A (depending on mode selection). The average output current limit calculation is shown in [Equation 4](#).

During the overcurrent protection event, the output voltage droops if the duty cycle cannot satisfy output voltage requirements and continues to droop until the UVP limit is reached. Then, the converter de-asserts the PGOOD pin, and then enters hiccup mode after a 250- $\mu$ s delay. The converter remains in hiccup mode until the fault is cleared.

$$I_{OCL(dc)} = I_{OCL(valley)} + \frac{1}{2} \times I_{P-P} \quad (4)$$

## Feature Description (continued)

### 7.3.5.5.2 Negative OCL

The negative OCL circuit acts when the converter is sinking current from the output capacitor(s). The converter continues to act in a *valley* mode, the typical value of the negative OCL set point is  $-9.3$  A or  $-6.5$  A (depending on mode selection).

### 7.3.6 Thermal Protection

The TPS53317 device has an internal temperature sensor. When the temperature reaches a nominal  $145^{\circ}\text{C}$ , the device shuts down until the temperature decreases by approximately  $10^{\circ}\text{C}$ , when the converter restarts.

## 7.4 Device Functional Modes

### 7.4.1 Non-Droop Configuration

The TPS53317 device can be configured as a non-droop solution. The benefit of a non-droop approach is that load regulation is flat, therefore, in a system where tight DC tolerance is desired, the non-droop approach is recommended. For the Intel system agent application, non-droop is recommended as the standard configuration.

The non-droop approach can be implemented by connecting a resistor and a capacitor between the COMP and the VREF pins. The purpose of the type II compensation is to obtain high DC feedback gain while minimizing the phase delay at unity gain cross over frequency of the converter.

The value of the resistor ( $R_C$ ) can be calculated using the desired unity gain bandwidth of the converter, and the value of the capacitor ( $C_C$ ) can be calculated by knowing where the zero location is desired. The capacitor  $C_P$  is optional, but recommended. Its appropriate capacitance value can be calculated using the desired pole location.

Figure 22 shows the basic implementation of the non-droop mode using the device

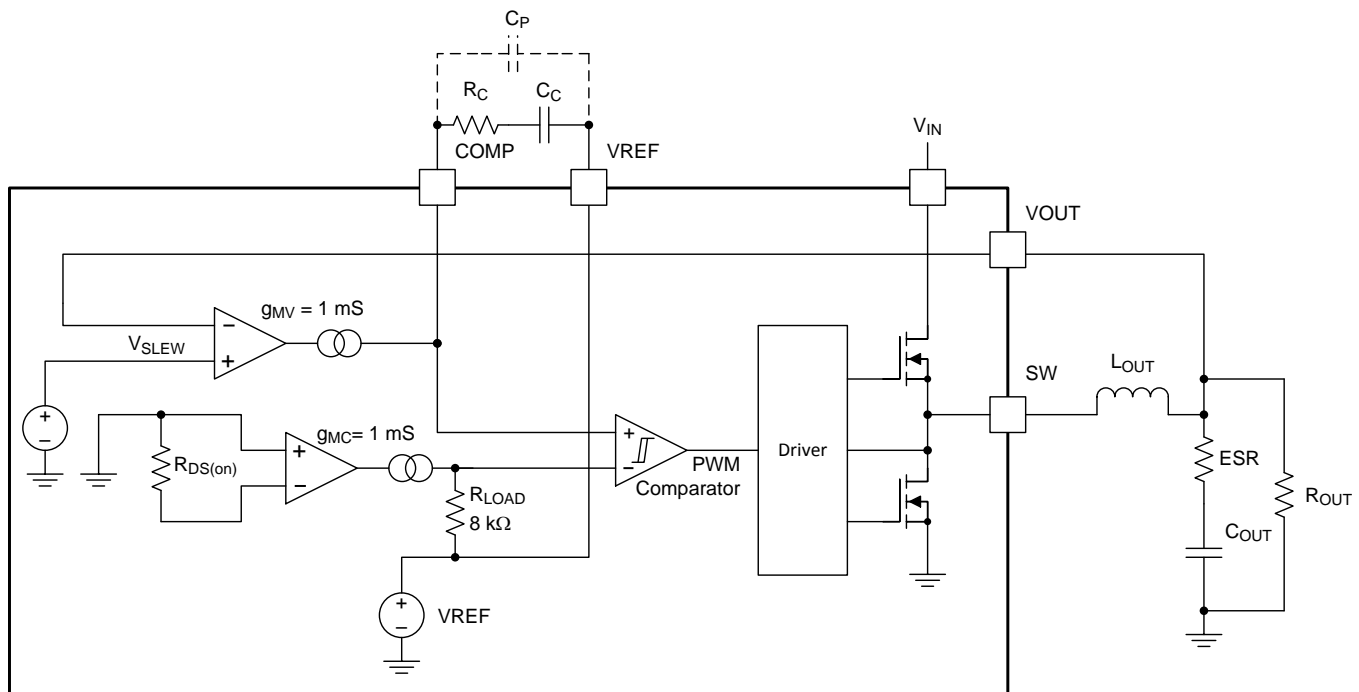
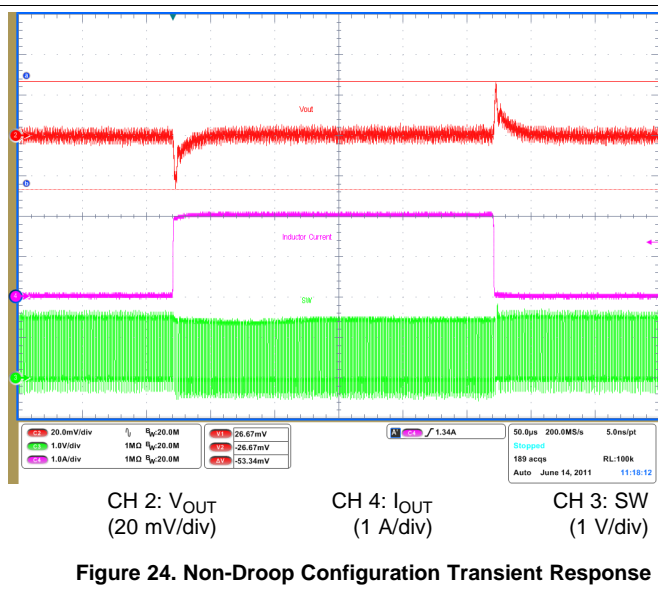
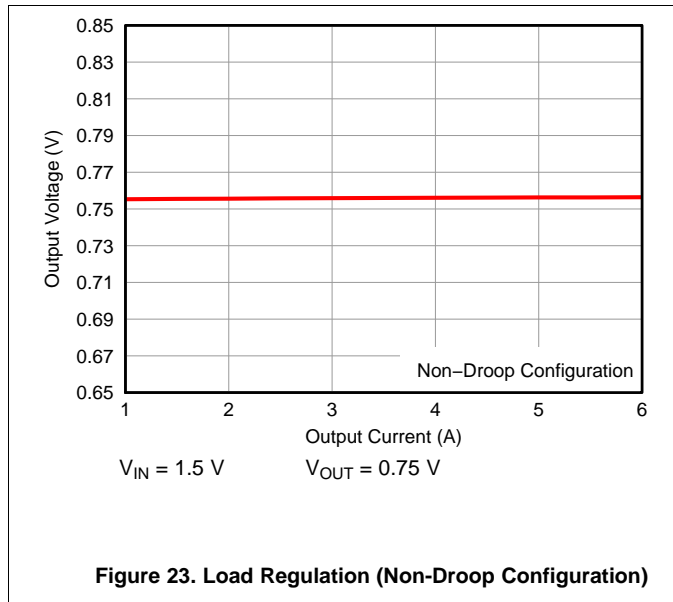

**Figure 22. Non-Droop Mode Basic Implementation**

### Device Functional Modes (continued)

Figure 23 shows shows the load regulation using non-droop configuration.

Figure 24 shows the transient response of the device using non-droop configuration, where  $C_{OUT} = 3 \times 47 \mu\text{F}$ . The applied step load is from 0 A to 2 A.



### 7.4.2 Droop Configuration

The terminology for droop is the same as *load line* or *voltage positioning* as defined in the Intel CPU  $V_{CORE}$  specification. Based on the actual tolerance requirement of the application, load-line set points can be defined to maximize either cost savings (by reducing output capacitors) or power reduction benefits.

Accurate droop voltage response is provided by the finite gain of the droop amplifier. The equation for droop voltage is shown in Equation 5.

$$V_{DROOP} = \frac{A_{CSINT} \times I_{OUT}}{R_{DROOP} \times g_M}$$

where

- low-side on-resistance is used as the current sensing element
  - $A_{CSINT}$  is a constant, which nominally is 53 mV/A.
  - $I_{OUT}$  is the DC current of the inductor, or the load current
  - $R_{DROOP}$  is the value of resistor from the COMP pin to the VREF pin
  - $g_M$  is the transconductance of the droop amplifier with nominal value of 1 mS
- (5)

Equation 6 can be used to easily derive  $R_{DROOP}$  for any load line slope/droop design target.

$$R_{LOAD\_LINE} = \frac{V_{DROOP}}{I_{OUT}} = \frac{A_{CSINT}}{R_{DROOP} \times g_M} \therefore R_{DROOP} = \frac{A_{CSINT}}{R_{LOAD\_LINE} \times g_M}$$

(6)

Device Functional Modes (continued)

Figure 25 shows the basic implementation of the droop mode using the TPS53317 device.

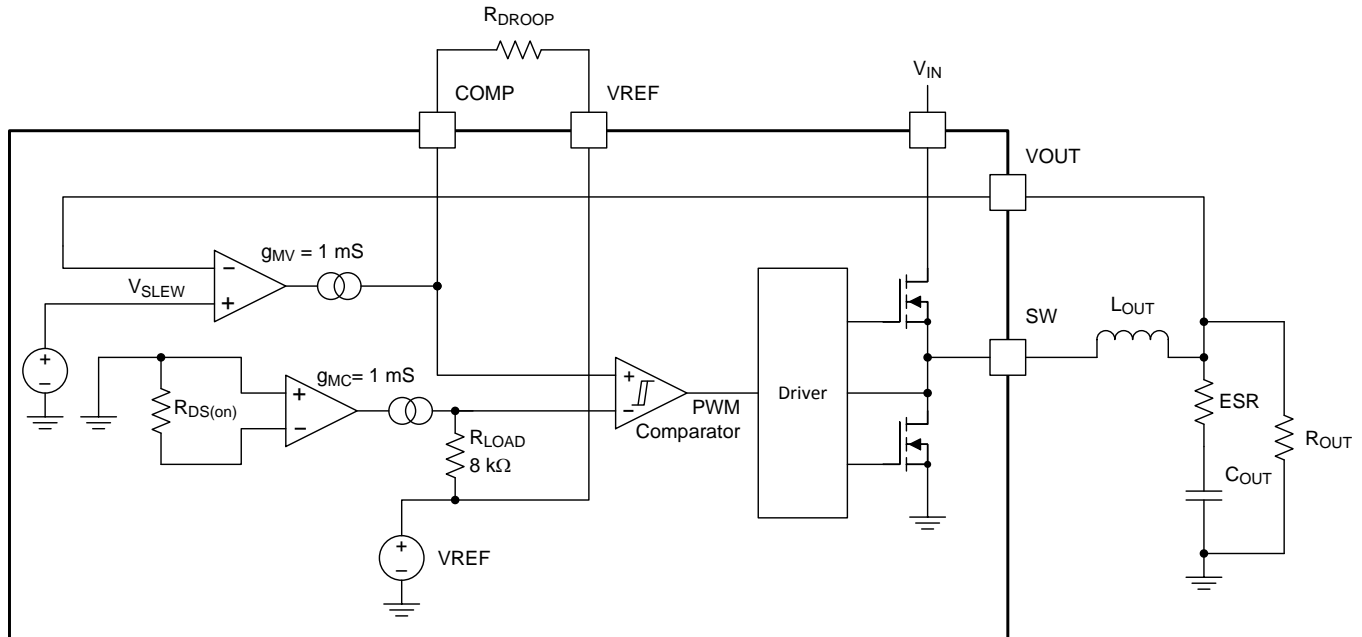

Figure 25. DROOP Mode Basic Implementation

The droop (voltage positioning) method was originally recommended to reduce the number of external output capacitors required. The effective transient voltage range is increased because of the active voltage positioning (see Figure 26).

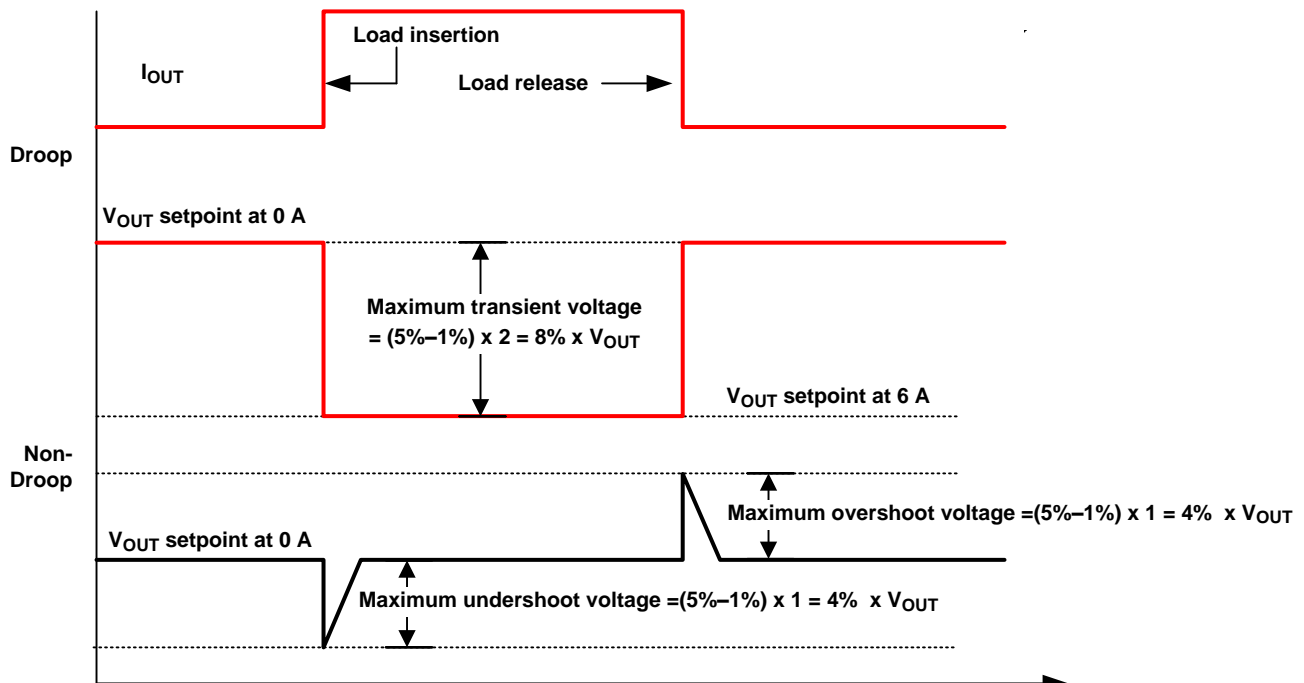

Figure 26. DROOP vs Non-DROOP in Transient Voltage Window

### Device Functional Modes (continued)

In applications where the DC and the AC tolerances are not separated, (meaning that there is no strict DC tolerance requirement) the droop method can be used.

Table 1. Mode Definitions

MODE	MODE RESISTANCE (kΩ)	LIGHT-LOAD POWER SAVING MODE	SWITCHING FREQUENCY (f <sub>sw</sub> )	OVERCURRENT LIMIT (OCL) VALLEY (A)
1	0	SKIP	600 kHz	7.6
2	12		600 kHz	5.4
3	22		1 MHz	5.4
4	33		1 MHz	7.6
5	47	PWM	600 kHz	7.6
6	68		600 kHz	5.4
7	100		1 MHz	5.4
8	OPEN		1 MHz	7.6

Figure 27 shows the load regulation of the 1.5-V rail using an R<sub>DROOP</sub> value of 6.8 kΩ.

Figure 28 shows the transient response of the TPS53317 device using droop configuration and C<sub>OUT</sub> = 3 × 47 μF. The applied step load is from 0 A to 2 A.

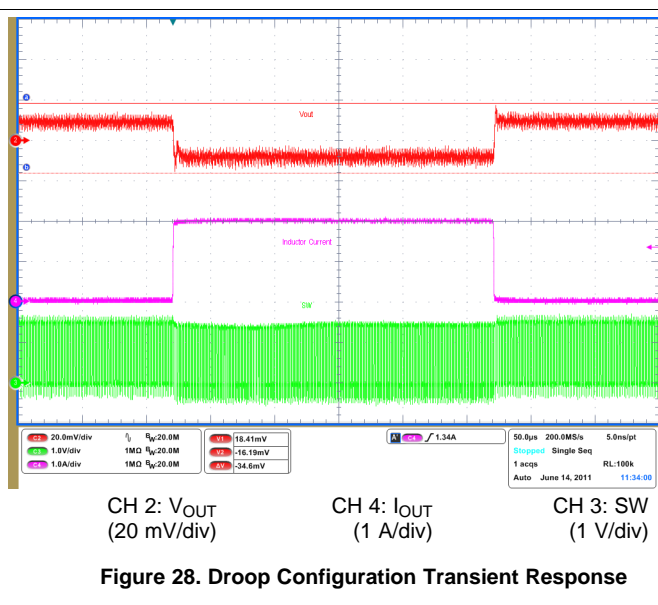
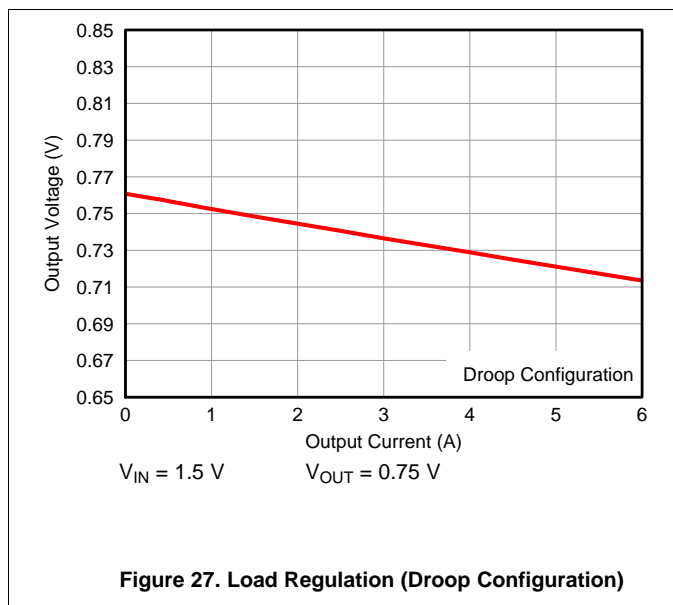

## 8 Application and Implementation

### NOTE

Information in the following applications sections is not part of the TI component specification, and TI does not warrant its accuracy or completeness. TI's customers are responsible for determining suitability of components for their purposes. Customers should validate and test their design implementation to confirm system functionality.

### 8.1 Application Information

The TPS53317 device is a FET-integrated synchronous buck regulator designed mainly for DDR termination. It can provide a regulated output at  $\frac{1}{2}$  VDDQ with both sink and source capability. The device employs D-CAP+ mode operation that provides ease-of-use, low external component count and fast transient response.

### 8.2 Typical Applications

#### 8.2.1 DDR4 SDRAM Application

This DDR4 application requires a tight load tolerance, fast transient response, and sinking current capability, the design uses a non-droop PWM configuration.

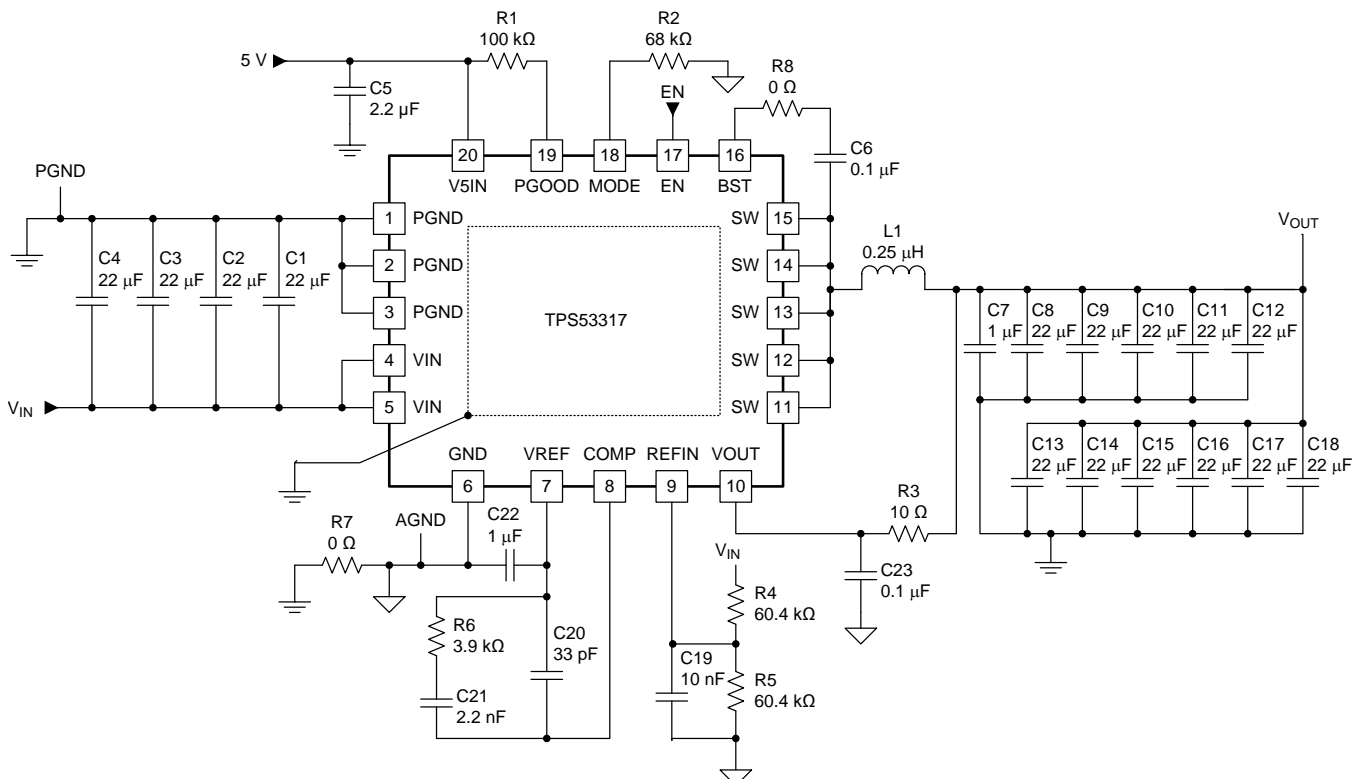

**Figure 29. DDR4 SDRAM Application**

#### 8.2.1.1 Design Requirements

- Input voltage :  $V_{IN} = 1.2$  V
- Output voltage:  $V_{OUT} = 0.6$  V
- Maximum load step size of 3 A @ slew rate 7 A/µs (–1.5 A to 1.5 A)
- DC +AC + Ripple voltage regulation limit at sense point:  $\pm 42$  mV (0.642 V overshoot, 0.558 V undershoot)
- Maximum load:  $I_{MAX} = 2.5$  A

## Typical Applications (continued)

### 8.2.1.2 Detailed Design Procedure

#### 8.2.1.2.1 Step 1. Determine Configuration

Because this DDR4 application requires a tight load tolerance, fast transient response, and sinking current capability, the design uses a non-droop PWM configuration. Choose 600-kHz switching frequency due to the duty cycle and minimum off-time of the device, and set an overcurrent (OC) valley limit of 5.4 A due to the maximum load requirement of 2.5 A. Referring to [Table 1](#) select an  $R_{MODE}$  value of 68 k $\Omega$ .

#### 8.2.1.2.2 Step 2. Select Inductor

Smaller inductor values have better transient performance but higher ripple and lower efficiency. High values have the opposite characteristics. It is common practice to limit the ripple current to 30% to 50% of the maximum current. Choose 50% to allow use of a smaller inductor for faster transient performance.

$$\Delta I_{P-P} = 2.5 A \times 0.5 = 1.25 A \quad (7)$$

$$L = \frac{1}{f_{SW} \times \Delta I_{P-P}} \times V_{OUT} \times (1 - D)$$

where

- D = duty cycle (8)

Because this device operates in DCAP+ mode, the frequency and duty cycle vary based on the input voltage, the output voltage and load. With a 2.5-A load, a 1.2-V input voltage and 0.60 V output voltage,  $f_{SW}$  is experimentally measured at approximately 800 kHz and duty cycle of 0.55. Therefore L is calculated as shown in [Equation 10](#).

$$L = \frac{1}{(800 \text{ kHz} \times 1.25 A)} \times 0.6V \times 0.45 = 0.270 \mu H \quad (9)$$

Choose the closest standard value, 0.25  $\mu$ H.

#### 8.2.1.2.3 Step 3. Determine Output Capacitance

Use [Equation 10](#) to calculate the output capacitance for a desired maximum overshoot.

$$C_{OUT(min),OS} = \frac{\Delta I_{OUT}^2 \times L}{2 \times V_{OUT} \times V_{OS}}$$

where

- $C_{OUT(min),OS}$  is the minimum output capacitance for a desired overshoot
- $\Delta I_{OUT}$  is the maximum output current change in the application
- $V_{OUT}$  = desired output voltage
- $V_{OS}$  is the desired output voltage change due to overshoot (10)

Choose a value of 30 mV to account for normal output voltage ripple.

$$C_{OUT(min),OS} = \frac{(3 A)^2 \times 0.25 \mu H}{2 \times 0.6 V \times 0.03 V} = 62.5 \mu F \quad (11)$$

Use [Equation 12](#) to calculate the necessary output capacitance for a desired maximum undershoot.

$$C_{OUT(min),US} = \frac{\Delta I_{OUT}^2 \times L \times \left( \frac{V_{OUT}}{V_{IN}} \times t_{SW} + t_{MIN(off)} \right)}{2 \times V_{OUT} \times V_{US} \times \left( \frac{V_{IN} - V_{OUT}}{V_{IN}} \times t_{SW} - t_{MIN(off)} \right)}$$

where

- $C_{OUT(min),US}$  is the minimum output capacitance for a desired undershoot
- $V_{US}$  is the desired output voltage change due to overshoot
- $t_{SW}$  is the period of switch node
- $t_{MIN(off)}$  is the minimum off-time (270 ns) (12)

## Typical Applications (continued)

Again, choose 30 mV to account for normal output voltage ripple.

$$C_{OUT(min),US} = \frac{(3 A)^2 \times 0.25 \mu H \times \left( \frac{0.6 V}{1.2 V} \times \frac{1}{800 kHz} + 270 ns \right)}{2 \times 0.6 V \times 0.03 V \times \left( \frac{1.2 V - 0.6 V}{1.2 V} \times \frac{1}{800 kHz} - 270 ns \right)} = 157.6 \mu F \quad (13)$$

The undershoot requirements determine, so there must be a minimum of 157.6  $\mu F$ . Because this is a DDR application where size is also a consideration, this design uses only ceramic capacitors. To account for voltage de-rating of capacitors and provide additional margin, this design includes eleven 22- $\mu F$  output capacitors.

### 8.2.1.2.4 Step 4. Input Capacitance

This design requires sufficient input capacitance to filter the input current from the host source. Use [Equation 14](#) to calculate the necessary input capacitance.

$$C_{IN(min)} = I_{out} \times \frac{D \times (1 - D)}{\Delta V_{IN(P-P)} \times f_{SW}}$$

where

- $\Delta V_{IN(P-P)}$  is the desired input voltage ripple (typically 1% of the input voltage) (14)

$$C_{IN(min)} = 2.5 A \times \frac{0.55 \times (1 - 0.55)}{12 mV \times 800 kHz} = 64.45 \mu F \quad (15)$$

As with the output capacitance selection, this design accounts for voltage de-rating of capacitors and provides additional margin, using four 22- $\mu F$  input capacitors.

### 8.2.1.2.5 Step 5. Compensation Network

In order to achieve stable operation, the crossover frequency should be less than 1/5 of the switching frequency.

$$f_{CO} = \frac{1}{2\pi} \times \frac{g_M}{C_{OUT}} \times \frac{R_C}{R_S} = 80 kHz$$

where

- $R_S = 53 m\Omega$  (16)

Account for capacitor de-rating here and set the value of  $C_{OUT}$  to 160  $\mu F$ , so that [Equation 17](#) is true.

$$R_C = \frac{f_{CO} \times R_S \times 2\pi \times C_{OUT}}{g_M} = \frac{80 kHz \times 53 m\Omega \times 2\pi \times 160 \mu F}{1 mS} = 4.26 k\Omega \quad (17)$$

Choose an  $R_C$  value of 3.9  $k\Omega$ . Determine  $C_C$  by choosing the value of the zero created by  $R_C$  and  $C_C$ . Using the relationship described in [Equation 18](#).

$$f_z = \frac{f_{CO}}{5} = \frac{1}{2\pi \times R_C \times C_C} \quad (18)$$

[Equation 18](#) yields a  $C_C$  value of 2.55 nF. Choose the closest common capacitor value of 2.2 nF. To determine a value for  $C_P$ , first consider the relationship described in [Equation 19](#).

$$f_p = \frac{1}{2\pi \times R_C \times \frac{C_C \times C_P}{C_C + C_P}} \approx \frac{1}{2\pi \times R_C \times C_P} \quad (19)$$

- $C_C \gg C_P$

Because  $C_C \gg C_P$ , set the pole to be two times the switching frequency as described in [Equation 20](#).

$$C_P \cong \frac{1}{2\pi \times R_C \times 2f_{SW}} = \frac{1}{2\pi \times 3.9 k\Omega \times 2 \times 800 kHz} = 25.5 pF \quad (20)$$

To boost the gain margin, set  $C_P$  to 33 pF.

Typical Applications (continued)

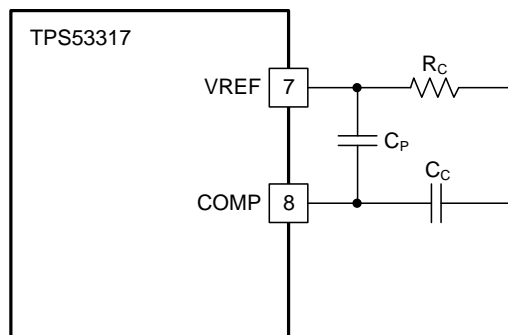

Figure 30. Compensation Network Circuit

8.2.1.2.6 Peripheral Component Selection

As described in Table 1, connect a 0.22- $\mu$ F capacitor from the VREF pin to GND and connect a 0.1- $\mu$ F bootstrap capacitor from the SW pin to the BST pin. Because the PGOOD pin is open drain, connect a pullup resistor between it and the 5-V rail.

8.2.1.3 Application Curves

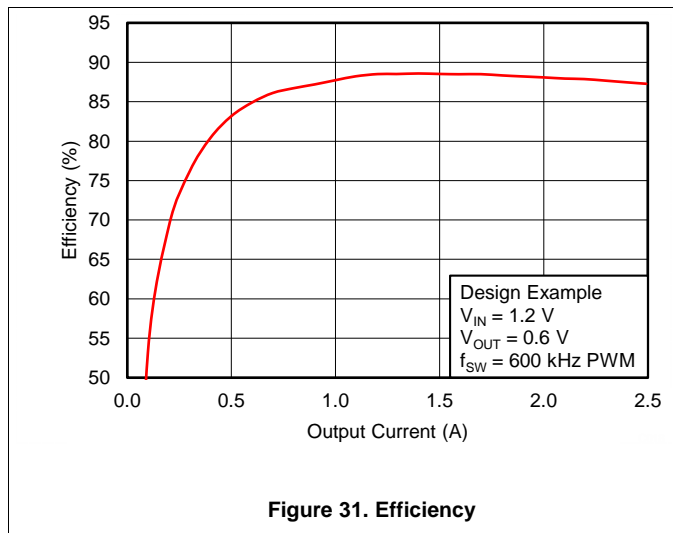

Figure 31. Efficiency

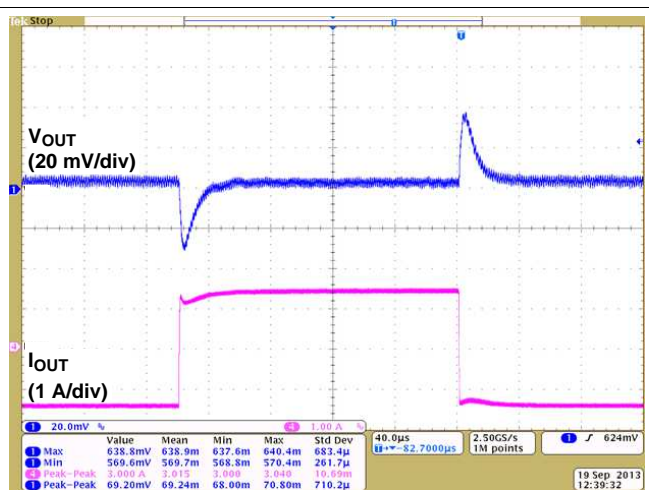

Figure 32. Load Transient

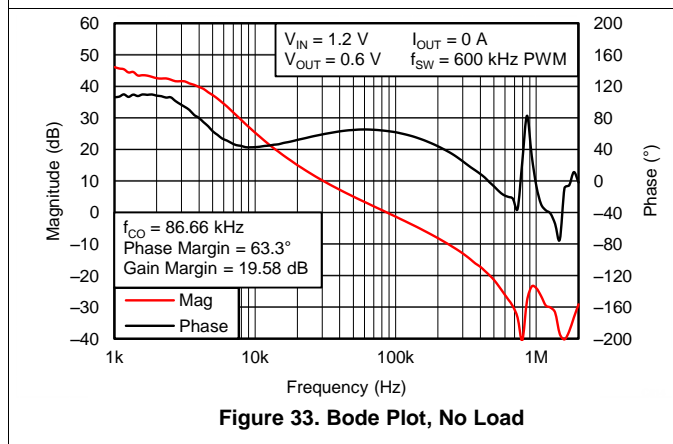

Figure 33. Bode Plot, No Load

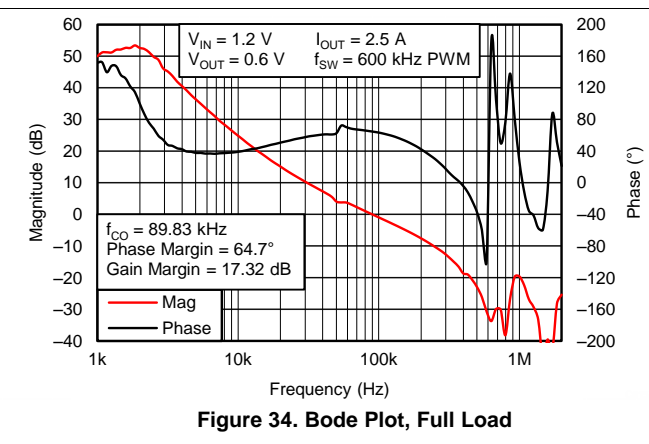
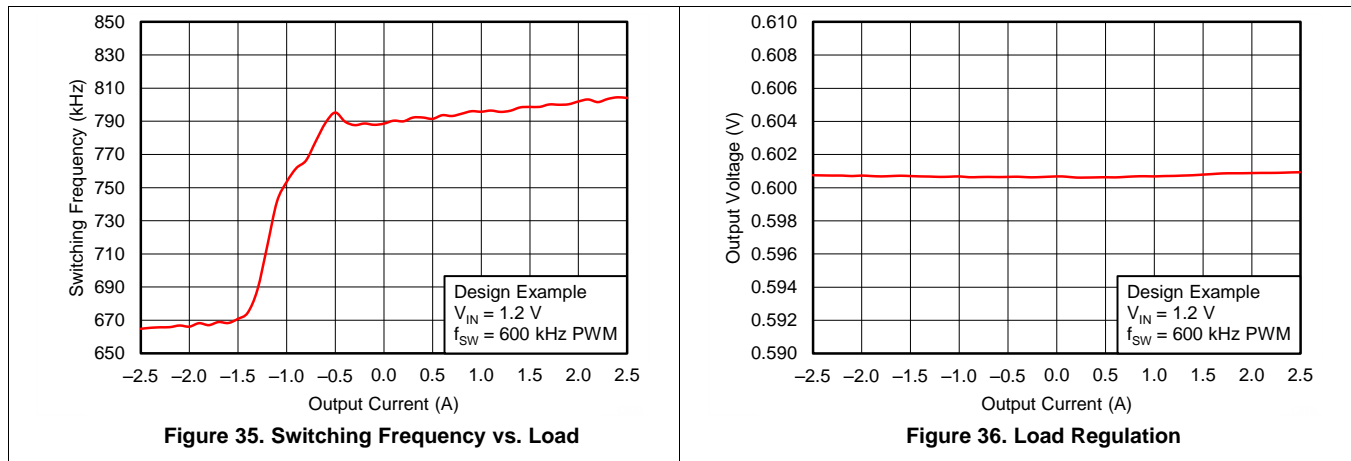

Figure 34. Bode Plot, Full Load

### Typical Applications (continued)



### 8.2.2 DDR3 SDRAM Application

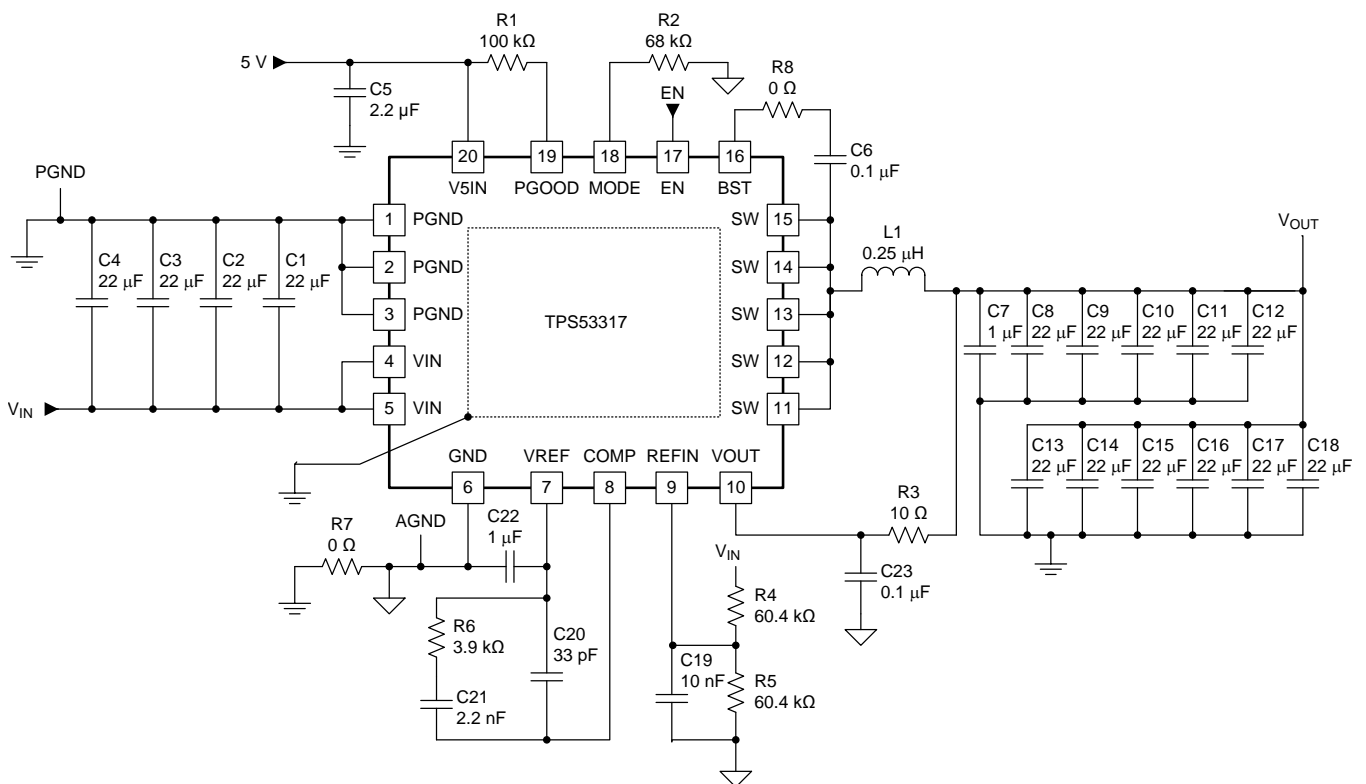

Figure 37. Typical Application Schematic, DDR3

#### 8.2.2.1 Design Requirements

- $V_{IN} = 1.5\text{ V}$
- $V_{OUT} = 0.75\text{ V}$

Typical Applications (continued)

8.2.3 Non-Tracking Point-of-Load (POL) Application

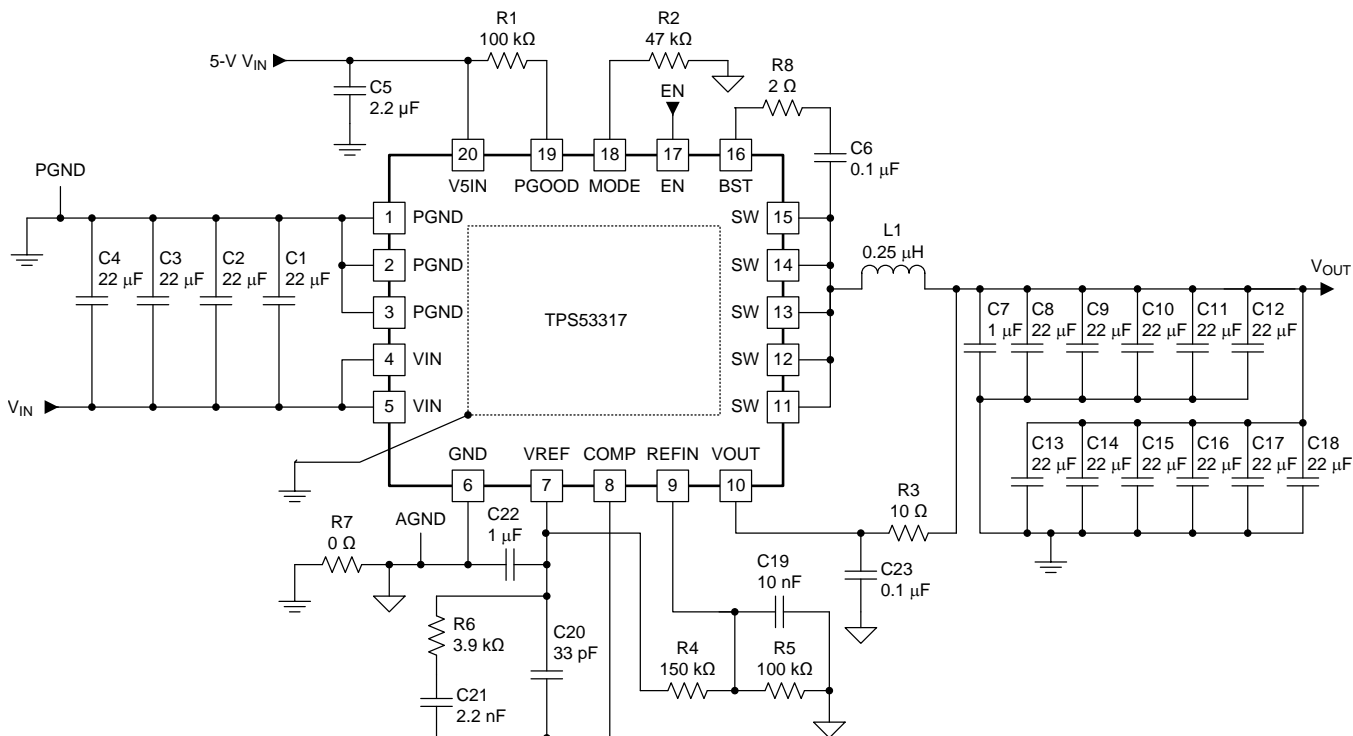

Figure 38. Typical Application Schematic, Non-Tracking Point-of-Load (POL)

8.2.3.1 Design Requirements

- $V_{IN} = 3.3\text{ V}$
- $V_{OUT} = 1.2\text{ V}$

8.2.3.2 Application Curves

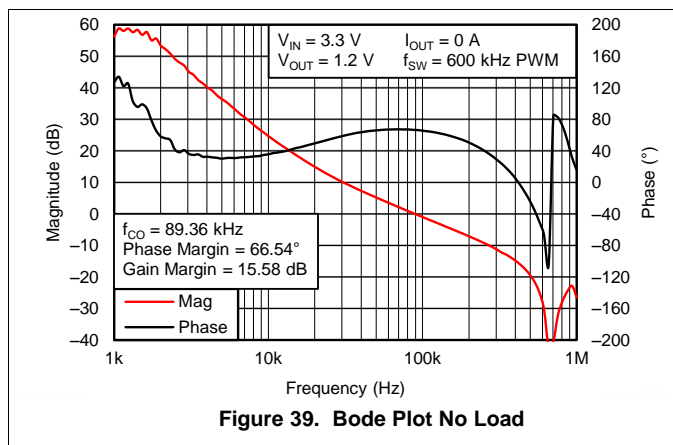

Figure 39. Bode Plot No Load

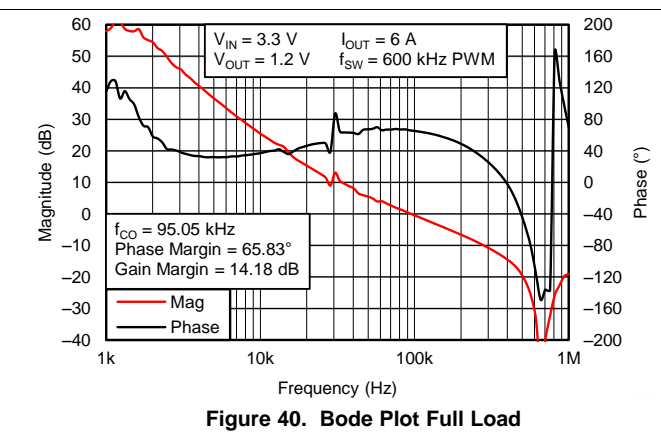

Figure 40. Bode Plot Full Load

## 9 Power Supply Recommendations

This device operates from an input voltage supply between 1 V and 6 V. This device requires a separate 5-V power supply for analog circuits and gate drive. Use the proper bypass capacitors for both the input supply and the 5-V supply in order to filter noise and to ensure proper device operation.

## 10 Layout

### 10.1 Layout Guidelines

Stable power supply operation depends on proper layout. Follow these guidelines for an optimized PCB layout.

- Connect PGND pins to the thermal pad underneath the device. Use four vias to connect the thermal pad to internal ground planes.
- Place VIN, V5IN and VREF decoupling capacitors as close to the device as possible.
- Use wide traces for the VIN, PGND and SW pins. These nodes carry high current and also serve as heat sinks.
- Place feedback and compensation components as close to the device as possible.
- Place COMP and VOUT analog signal traces away from noisy signals (SW, BST).
- The GND pin should connect to the PGND in only one place, through a via or a 0-Ω resistor.

### 10.2 Layout Example

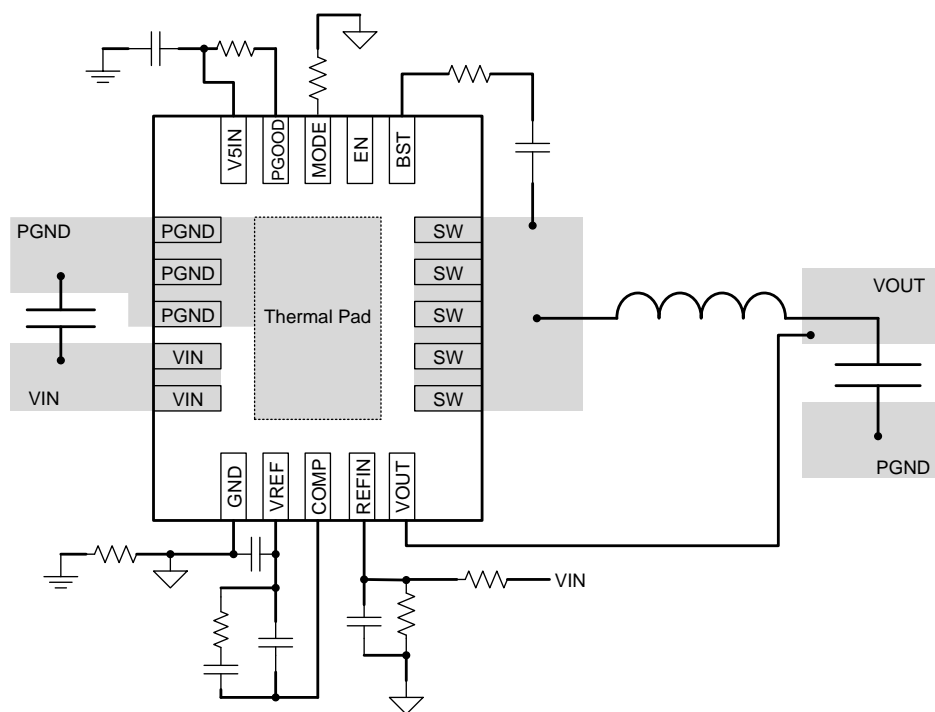

**Figure 41. TPS53317 Board Layout**

## 11 Device and Documentation Support

### 11.1 Community Resources

The following links connect to TI community resources. Linked contents are provided "AS IS" by the respective contributors. They do not constitute TI specifications and do not necessarily reflect TI's views; see TI's [Terms of Use](#).

**TI E2E™ Online Community** *TI's Engineer-to-Engineer (E2E) Community*. Created to foster collaboration among engineers. At [e2e.ti.com](http://e2e.ti.com), you can ask questions, share knowledge, explore ideas and help solve problems with fellow engineers.

**Design Support** *TI's Design Support* Quickly find helpful E2E forums along with design support tools and contact information for technical support.

### 11.2 Trademarks

D-CAP+, D-CAP+, E2E are trademarks of Texas Instruments.  
All other trademarks are the property of their respective owners.

### 11.3 Electrostatic Discharge Caution



These devices have limited built-in ESD protection. The leads should be shorted together or the device placed in conductive foam during storage or handling to prevent electrostatic damage to the MOS gates.

### 11.4 Glossary

[SLYZ022](#) — *TI Glossary*.

This glossary lists and explains terms, acronyms, and definitions.

## 12 Mechanical, Packaging, and Orderable Information

The following pages include mechanical, packaging, and orderable information. This information is the most current data available for the designated devices. This data is subject to change without notice and revision of this document. For browser-based versions of this data sheet, refer to the left-hand navigation.

**PACKAGING INFORMATION**

Orderable Device	Status (1)	Package Type	Package Drawing	Pins	Package Qty	Eco Plan (2)	Lead/Ball Finish (6)	MSL Peak Temp (3)	Op Temp (°C)	Device Marking (4/5)	Samples
DPA02257RGBR	ACTIVE	VQFN	RGB	20	3000	Green (RoHS & no Sb/Br)	CU NIPDAU	Level-2-260C-1 YEAR	-40 to 85	53317	<a href="#">Samples</a>
TPS53317RGBR	ACTIVE	VQFN	RGB	20	3000	Green (RoHS & no Sb/Br)	CU NIPDAU	Level-2-260C-1 YEAR	-40 to 85	53317	<a href="#">Samples</a>
TPS53317RGBT	ACTIVE	VQFN	RGB	20	250	Green (RoHS & no Sb/Br)	CU NIPDAU	Level-2-260C-1 YEAR	-40 to 85	53317	<a href="#">Samples</a>

(1) The marketing status values are defined as follows:

**ACTIVE:** Product device recommended for new designs.

**LIFEBUY:** TI has announced that the device will be discontinued, and a lifetime-buy period is in effect.

**NRND:** Not recommended for new designs. Device is in production to support existing customers, but TI does not recommend using this part in a new design.

**PREVIEW:** Device has been announced but is not in production. Samples may or may not be available.

**OBsolete:** TI has discontinued the production of the device.

(2) Eco Plan - The planned eco-friendly classification: Pb-Free (RoHS), Pb-Free (RoHS Exempt), or Green (RoHS & no Sb/Br) - please check <http://www.ti.com/productcontent> for the latest availability information and additional product content details.

**TBD:** The Pb-Free/Green conversion plan has not been defined.

**Pb-Free (RoHS):** TI's terms "Lead-Free" or "Pb-Free" mean semiconductor products that are compatible with the current RoHS requirements for all 6 substances, including the requirement that lead not exceed 0.1% by weight in homogeneous materials. Where designed to be soldered at high temperatures, TI Pb-Free products are suitable for use in specified lead-free processes.

**Pb-Free (RoHS Exempt):** This component has a RoHS exemption for either 1) lead-based flip-chip solder bumps used between the die and package, or 2) lead-based die adhesive used between the die and leadframe. The component is otherwise considered Pb-Free (RoHS compatible) as defined above.

**Green (RoHS & no Sb/Br):** TI defines "Green" to mean Pb-Free (RoHS compatible), and free of Bromine (Br) and Antimony (Sb) based flame retardants (Br or Sb do not exceed 0.1% by weight in homogeneous material)

(3) MSL, Peak Temp. - The Moisture Sensitivity Level rating according to the JEDEC industry standard classifications, and peak solder temperature.

(4) There may be additional marking, which relates to the logo, the lot trace code information, or the environmental category on the device.

(5) Multiple Device Markings will be inside parentheses. Only one Device Marking contained in parentheses and separated by a "~" will appear on a device. If a line is indented then it is a continuation of the previous line and the two combined represent the entire Device Marking for that device.

(6) Lead/Ball Finish - Orderable Devices may have multiple material finish options. Finish options are separated by a vertical ruled line. Lead/Ball Finish values may wrap to two lines if the finish value exceeds the maximum column width.

**Important Information and Disclaimer:** The information provided on this page represents TI's knowledge and belief as of the date that it is provided. TI bases its knowledge and belief on information provided by third parties, and makes no representation or warranty as to the accuracy of such information. Efforts are underway to better integrate information from third parties. TI has taken and

continues to take reasonable steps to provide representative and accurate information but may not have conducted destructive testing or chemical analysis on incoming materials and chemicals. TI and TI suppliers consider certain information to be proprietary, and thus CAS numbers and other limited information may not be available for release.

In no event shall TI's liability arising out of such information exceed the total purchase price of the TI part(s) at issue in this document sold by TI to Customer on an annual basis.

**TAPE AND REEL INFORMATION**

**QUADRANT ASSIGNMENTS FOR PIN 1 ORIENTATION IN TAPE**

\*All dimensions are nominal

Device	Package Type	Package Drawing	Pins	SPQ	Reel Diameter (mm)	Reel Width W1 (mm)	A0 (mm)	B0 (mm)	K0 (mm)	P1 (mm)	W (mm)	Pin1 Quadrant
DPA02257RGBR	VQFN	RGB	20	3000	330.0	12.4	3.8	4.3	1.5	8.0	12.0	Q1
DPA02257RGBR	VQFN	RGB	20	3000	330.0	12.4	3.8	4.3	1.5	8.0	12.0	Q1
TPS53317RGBR	VQFN	RGB	20	3000	330.0	12.4	3.8	4.3	1.5	8.0	12.0	Q1
TPS53317RGBR	VQFN	RGB	20	3000	330.0	12.4	3.8	4.3	1.5	8.0	12.0	Q1
TPS53317RGBT	VQFN	RGB	20	250	180.0	12.4	3.8	4.3	1.5	8.0	12.0	Q1

**TAPE AND REEL BOX DIMENSIONS**

\*All dimensions are nominal

Device	Package Type	Package Drawing	Pins	SPQ	Length (mm)	Width (mm)	Height (mm)
DPA02257RGBR	VQFN	RGB	20	3000	367.0	367.0	35.0
DPA02257RGBR	VQFN	RGB	20	3000	367.0	367.0	35.0
TPS53317RGBR	VQFN	RGB	20	3000	367.0	367.0	35.0
TPS53317RGBR	VQFN	RGB	20	3000	552.0	367.0	36.0
TPS53317RGBT	VQFN	RGB	20	250	210.0	185.0	35.0

RGB (R-PVQFN-N20)

PLASTIC QUAD FLATPACK NO-LEAD

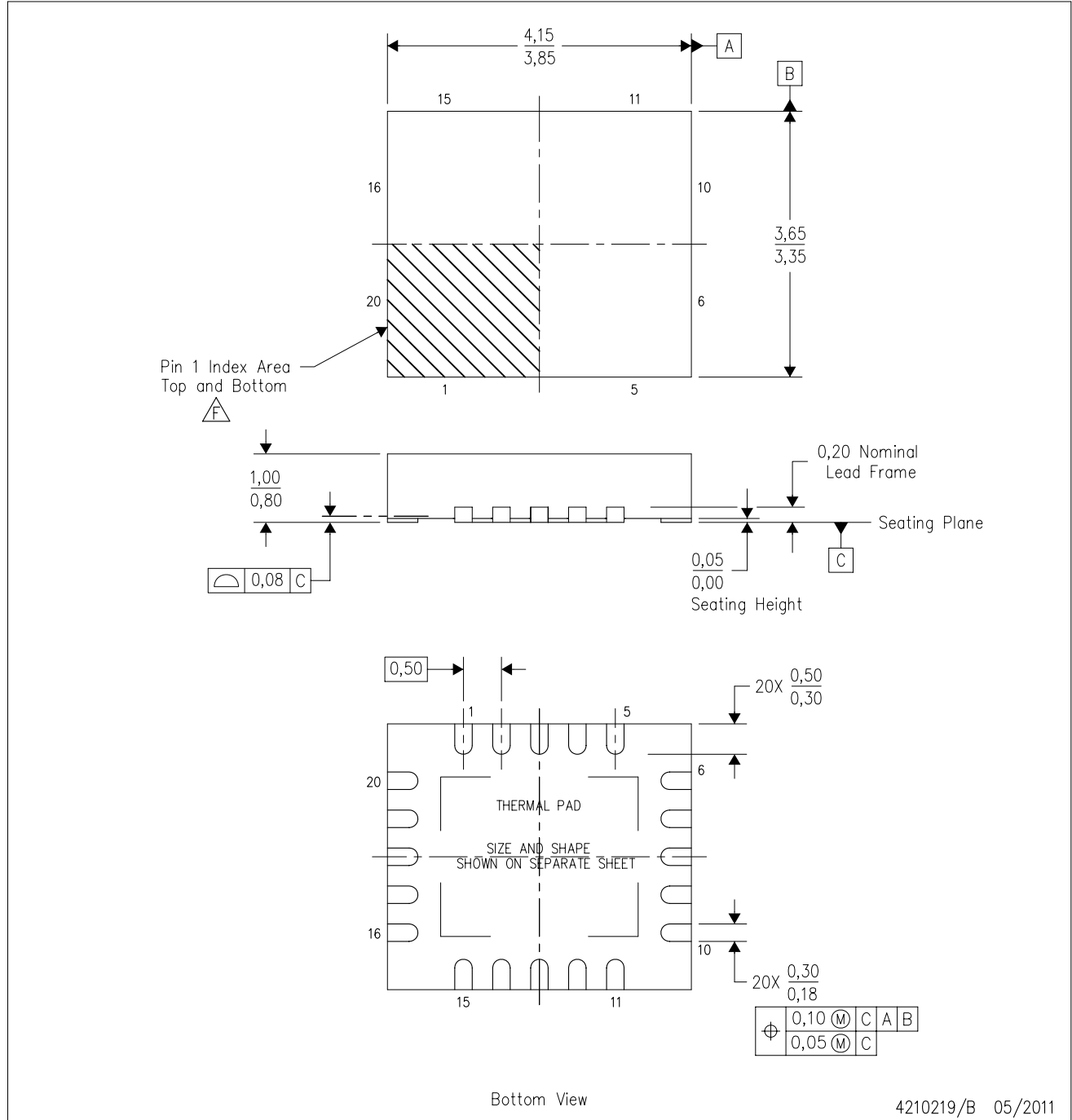

4210219/B 05/2011

- NOTES:
- A. All linear dimensions are in millimeters. Dimensioning and tolerancing per ASME Y14.5M-1994.
  - B. This drawing is subject to change without notice.
  - C. QFN (Quad Flatpack No-Lead) package configuration.
  - D. The package thermal pad must be soldered to the board for thermal and mechanical performance.
  - E. See the additional figure in the Product Data Sheet for details regarding the exposed thermal pad features and dimensions.
- △ Pin 1 identifiers are located on both top and bottom of the package and within the zone indicated. The Pin 1 identifiers are either a molded, marked, or metal feature.

## THERMAL PAD MECHANICAL DATA

RGB (R-PVQFN-N20)

PLASTIC QUAD FLATPACK NO-LEAD

### THERMAL INFORMATION

This package incorporates an exposed thermal pad that is designed to be attached directly to an external heatsink. The thermal pad must be soldered directly to the printed circuit board (PCB). After soldering, the PCB can be used as a heatsink. In addition, through the use of thermal vias, the thermal pad can be attached directly to the appropriate copper plane shown in the electrical schematic for the device, or alternatively, can be attached to a special heatsink structure designed into the PCB. This design optimizes the heat transfer from the integrated circuit (IC).

For information on the Quad Flatpack No-Lead (QFN) package and its advantages, refer to Application Report, QFN/SON PCB Attachment, Texas Instruments Literature No. SLUA271. This document is available at [www.ti.com](http://www.ti.com).

The exposed thermal pad dimensions for this package are shown in the following illustration.

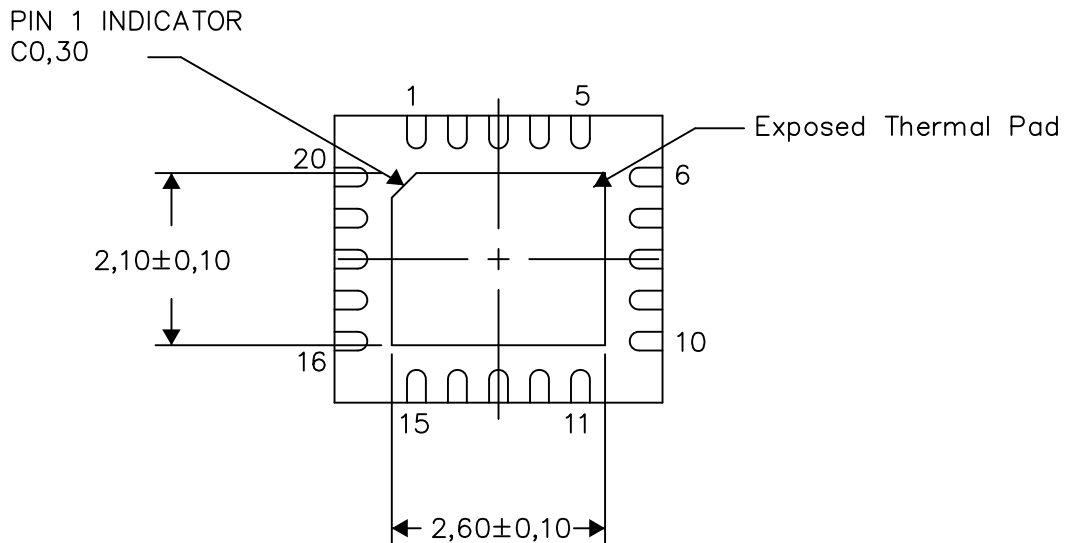

Bottom View

Exposed Thermal Pad Dimensions

4210242/C 05/12

NOTE: All linear dimensions are in millimeters

RGB (R-PVQFN-N20)

PLASTIC QUAD FLATPACK NO-LEAD

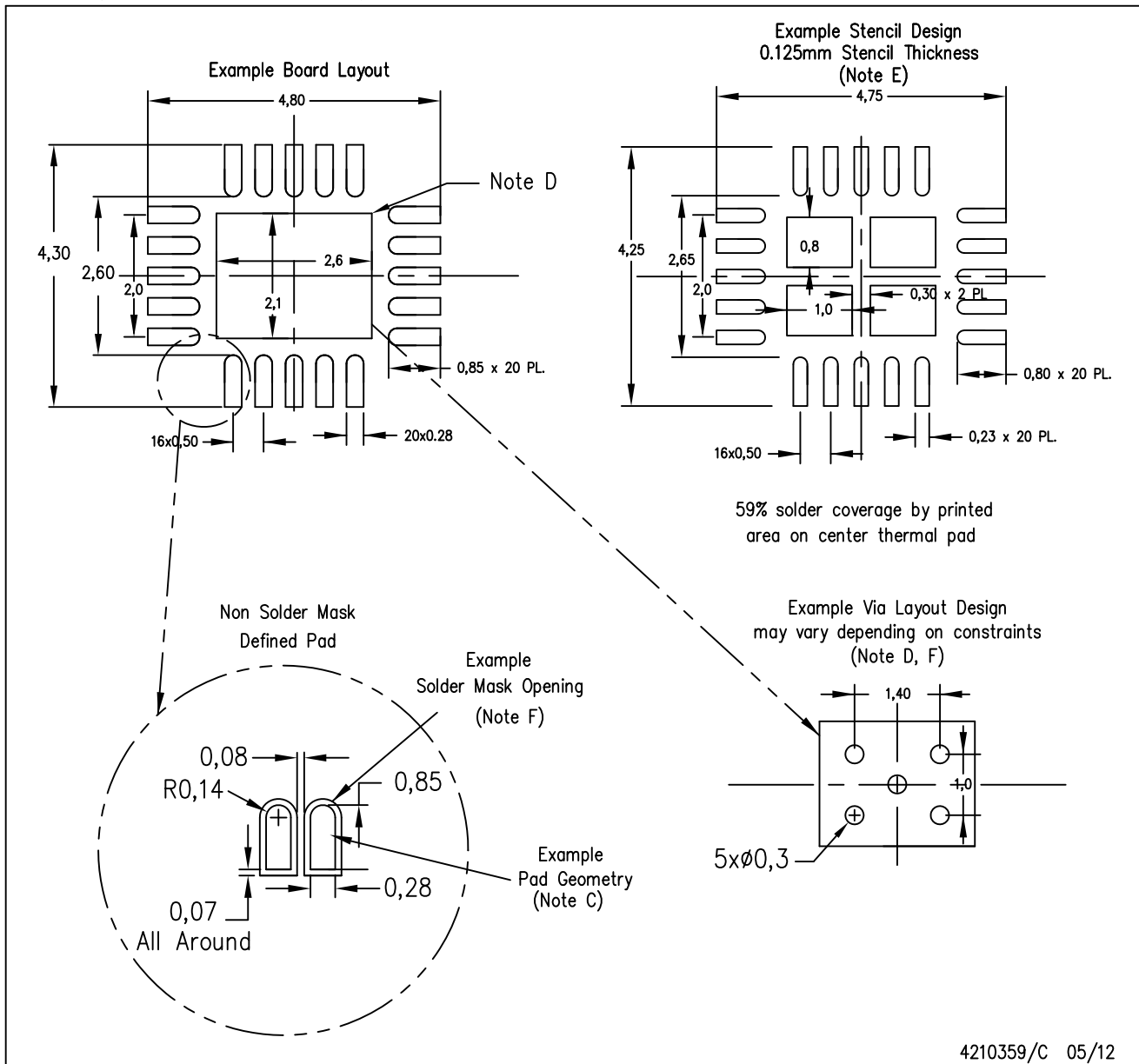

- NOTES:
- A. All linear dimensions are in millimeters.
  - B. This drawing is subject to change without notice.
  - C. Publication IPC-7351 is recommended for alternate designs.
  - D. This package is designed to be soldered to a thermal pad on the board. Refer to Application Note, Quad Flat-Pack QFN/SON PCB Attachment, Texas Instruments Literature No. SLUA271, and also the Product Data Sheets for specific thermal information, via requirements, and recommended board layout. These documents are available at [www.ti.com](http://www.ti.com) <<http://www.ti.com>>.
  - E. Laser cutting apertures with trapezoidal walls and also rounding corners will offer better paste release. Customers should contact their board assembly site for stencil design recommendations. Refer to IPC 7525 for stencil design considerations.
  - F. Customers should contact their board fabrication site for minimum solder mask web tolerances between signal pads.

## IMPORTANT NOTICE

Texas Instruments Incorporated and its subsidiaries (TI) reserve the right to make corrections, enhancements, improvements and other changes to its semiconductor products and services per JESD46, latest issue, and to discontinue any product or service per JESD48, latest issue. Buyers should obtain the latest relevant information before placing orders and should verify that such information is current and complete. All semiconductor products (also referred to herein as "components") are sold subject to TI's terms and conditions of sale supplied at the time of order acknowledgment.

TI warrants performance of its components to the specifications applicable at the time of sale, in accordance with the warranty in TI's terms and conditions of sale of semiconductor products. Testing and other quality control techniques are used to the extent TI deems necessary to support this warranty. Except where mandated by applicable law, testing of all parameters of each component is not necessarily performed.

TI assumes no liability for applications assistance or the design of Buyers' products. Buyers are responsible for their products and applications using TI components. To minimize the risks associated with Buyers' products and applications, Buyers should provide adequate design and operating safeguards.

TI does not warrant or represent that any license, either express or implied, is granted under any patent right, copyright, mask work right, or other intellectual property right relating to any combination, machine, or process in which TI components or services are used. Information published by TI regarding third-party products or services does not constitute a license to use such products or services or a warranty or endorsement thereof. Use of such information may require a license from a third party under the patents or other intellectual property of the third party, or a license from TI under the patents or other intellectual property of TI.

Reproduction of significant portions of TI information in TI data books or data sheets is permissible only if reproduction is without alteration and is accompanied by all associated warranties, conditions, limitations, and notices. TI is not responsible or liable for such altered documentation. Information of third parties may be subject to additional restrictions.

Resale of TI components or services with statements different from or beyond the parameters stated by TI for that component or service voids all express and any implied warranties for the associated TI component or service and is an unfair and deceptive business practice. TI is not responsible or liable for any such statements.

Buyer acknowledges and agrees that it is solely responsible for compliance with all legal, regulatory and safety-related requirements concerning its products, and any use of TI components in its applications, notwithstanding any applications-related information or support that may be provided by TI. Buyer represents and agrees that it has all the necessary expertise to create and implement safeguards which anticipate dangerous consequences of failures, monitor failures and their consequences, lessen the likelihood of failures that might cause harm and take appropriate remedial actions. Buyer will fully indemnify TI and its representatives against any damages arising out of the use of any TI components in safety-critical applications.

In some cases, TI components may be promoted specifically to facilitate safety-related applications. With such components, TI's goal is to help enable customers to design and create their own end-product solutions that meet applicable functional safety standards and requirements. Nonetheless, such components are subject to these terms.

No TI components are authorized for use in FDA Class III (or similar life-critical medical equipment) unless authorized officers of the parties have executed a special agreement specifically governing such use.

Only those TI components which TI has specifically designated as military grade or "enhanced plastic" are designed and intended for use in military/aerospace applications or environments. Buyer acknowledges and agrees that any military or aerospace use of TI components which have **not** been so designated is solely at the Buyer's risk, and that Buyer is solely responsible for compliance with all legal and regulatory requirements in connection with such use.

TI has specifically designated certain components as meeting ISO/TS16949 requirements, mainly for automotive use. In any case of use of non-designated products, TI will not be responsible for any failure to meet ISO/TS16949.

### Products

Audio	<a href="http://www.ti.com/audio">www.ti.com/audio</a>
Amplifiers	<a href="http://amplifier.ti.com">amplifier.ti.com</a>
Data Converters	<a href="http://dataconverter.ti.com">dataconverter.ti.com</a>
DLP® Products	<a href="http://www.dlp.com">www.dlp.com</a>
DSP	<a href="http://dsp.ti.com">dsp.ti.com</a>
Clocks and Timers	<a href="http://www.ti.com/clocks">www.ti.com/clocks</a>
Interface	<a href="http://interface.ti.com">interface.ti.com</a>
Logic	<a href="http://logic.ti.com">logic.ti.com</a>
Power Mgmt	<a href="http://power.ti.com">power.ti.com</a>
Microcontrollers	<a href="http://microcontroller.ti.com">microcontroller.ti.com</a>
RFID	<a href="http://www.ti-rfid.com">www.ti-rfid.com</a>
OMAP Applications Processors	<a href="http://www.ti.com/omap">www.ti.com/omap</a>
Wireless Connectivity	<a href="http://www.ti.com/wirelessconnectivity">www.ti.com/wirelessconnectivity</a>

### Applications

Automotive and Transportation	<a href="http://www.ti.com/automotive">www.ti.com/automotive</a>
Communications and Telecom	<a href="http://www.ti.com/communications">www.ti.com/communications</a>
Computers and Peripherals	<a href="http://www.ti.com/computers">www.ti.com/computers</a>
Consumer Electronics	<a href="http://www.ti.com/consumer-apps">www.ti.com/consumer-apps</a>
Energy and Lighting	<a href="http://www.ti.com/energy">www.ti.com/energy</a>
Industrial	<a href="http://www.ti.com/industrial">www.ti.com/industrial</a>
Medical	<a href="http://www.ti.com/medical">www.ti.com/medical</a>
Security	<a href="http://www.ti.com/security">www.ti.com/security</a>
Space, Avionics and Defense	<a href="http://www.ti.com/space-avionics-defense">www.ti.com/space-avionics-defense</a>
Video and Imaging	<a href="http://www.ti.com/video">www.ti.com/video</a>

### TI E2E Community

[e2e.ti.com](http://e2e.ti.com)