

Ultrafast Recovery Power Rectifier

General Description

The SFN5A300DN is ideally as boost diode in discontinuous or critical mode power factor corrections. The planar structure and the platinum doper life time control guarantee the best overall performance, ruggedness reliability characteristics. The device is also intended for use as a freewheeling diode in power supplies and other power switching applications.

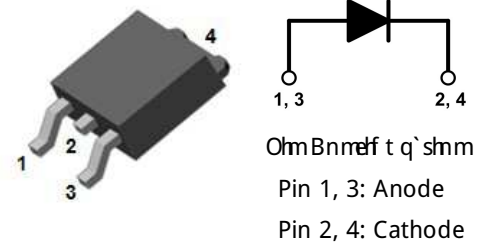

Features and Benefits

- Æ Low forward drop voltage
- Æ Ultrafast recovery time and high speed switching
- Æ Full lead (Pb)-free device and RoHS compliant device

Applications

- Æ Switching power supply
- Æ Power inverters
- Æ Power conversion system

Ordering Information

Part Number	Marking Code	Package	Packaging
SFN5A300DN	SFN5A300	TO-252	Tape & Reel

Marking Information

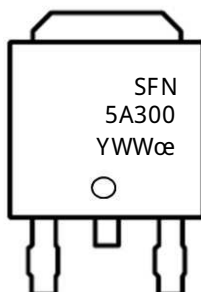

- SFN5A300 = Specific Device Code
 YWW = Year & Week Code Marking
 -. Y = Year Code
 -. WW = Week Code
 -. œ = Factory Management Code

Absolute Maximum Ratings (Limiting values at 25°C, unless otherwise specified)

Characteristic	Symbol	Ratings	Unit
Maximum repetitive reverse voltage Maximum working peak reverse voltage Maximum DC blocking voltage	V_{RRM} V_{RWM} V_R	300	V
Maximum average forward rectified current	$I_{F(AV)}$	5	A
Peak forward surge current 8.3ms single half sine-wave superimposed on rated load	I_{FSM}	120	A
Storage temperature range	T_{stg}	-45 to +150	°C
Maximum operating junction temperature	T_J	150	

Thermal Characteristics

Characteristic	Symbol	Ratings	Unit
Maximum thermal resistance	$R_{th(j-c)}$	4.0	°C/W

Electrical Characteristics

Characteristic	Symbol	Test Condition	Min.	Typ.	Max.	Unit	
Peak forward voltage drop	$V_{FM}^{1)}$	$I_F = 5A$ $T_J = 25^\circ C$	-	1.00	1.25	V	
Reverse leakage current	$I_{RM}^{2)}$	$V_R = V_{RRM}$	$T_J = 25^\circ C$	-	-	5	µA
			$T_J = 125^\circ C$	-	-	200	
Reverse recovery time	t_{rr}	$I_F = 1A, di/dt = -100 A/\mu s$	-	17	25	ns	
Junction capacitance	C_j	$V_R = 10V_{DC}, f = 1MHz$	-	33	-	pF	

¹⁾ Pulse test: $t_p \leq 380\mu s$, Duty cycle $\leq 2\%$

²⁾ Pulse test: $t_p \leq 20ms$, Duty cycle $\leq 2\%$

Typical Electrical Characteristic Curves

Fig. 1) Typical Forward Characteristics

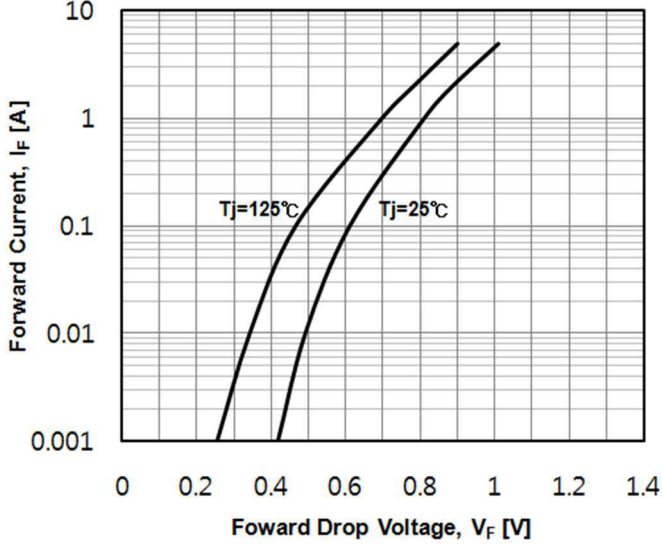

Fig. 2) Typical Reverse Characteristics

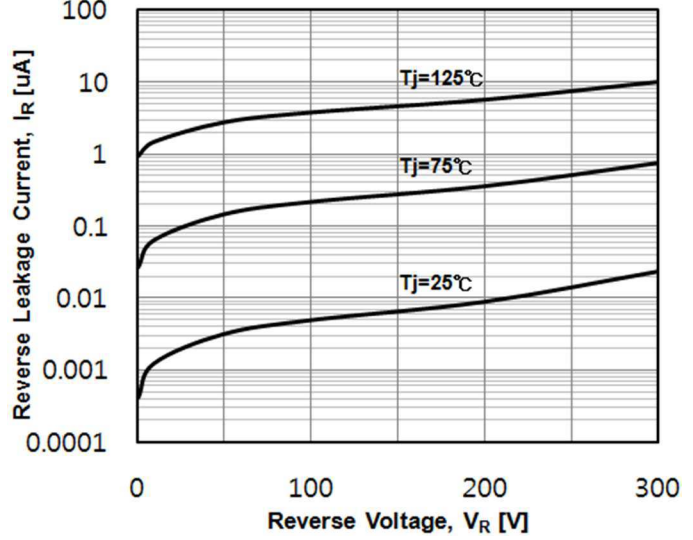

Fig. 3) Typical Junction Capacitance Characteristics

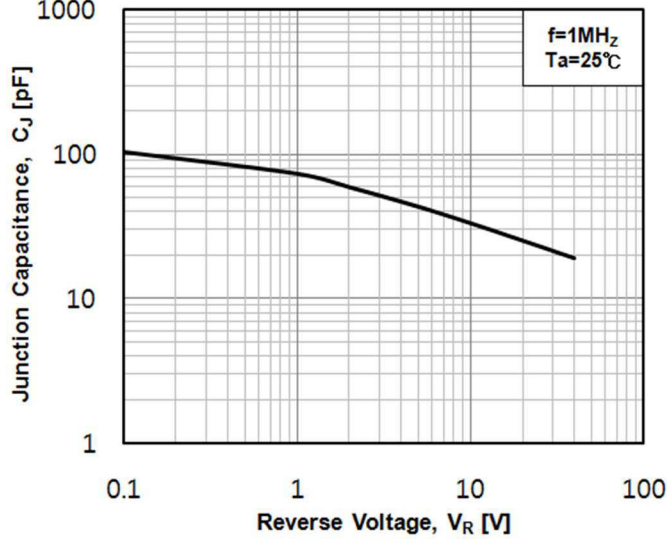

Fig. 4) Peak Forward Surge Current Characteristics

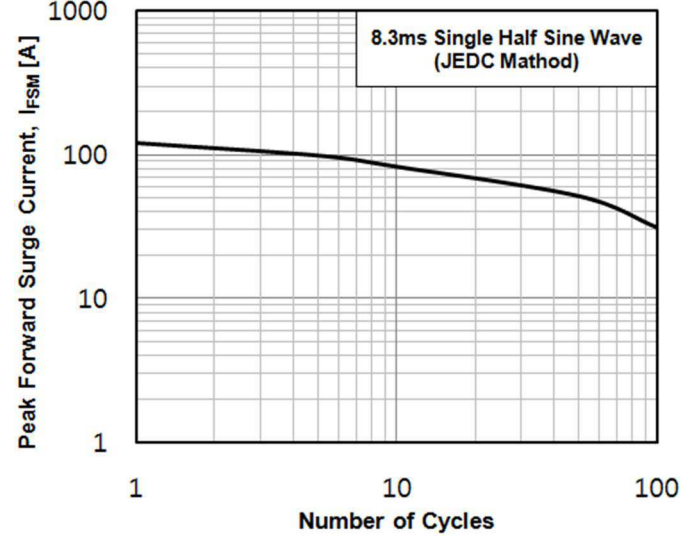

Fig. 5) Thermal Impedance Characteristics

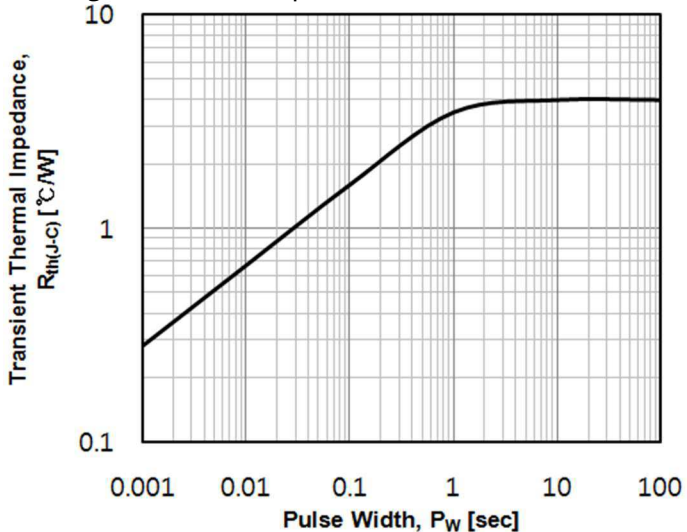
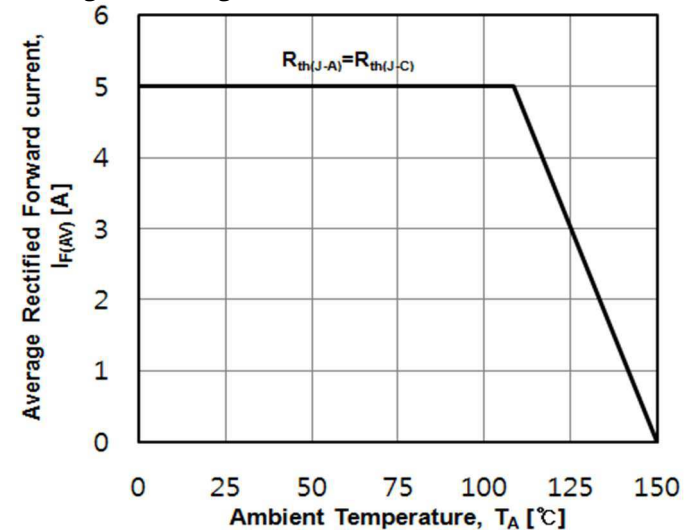
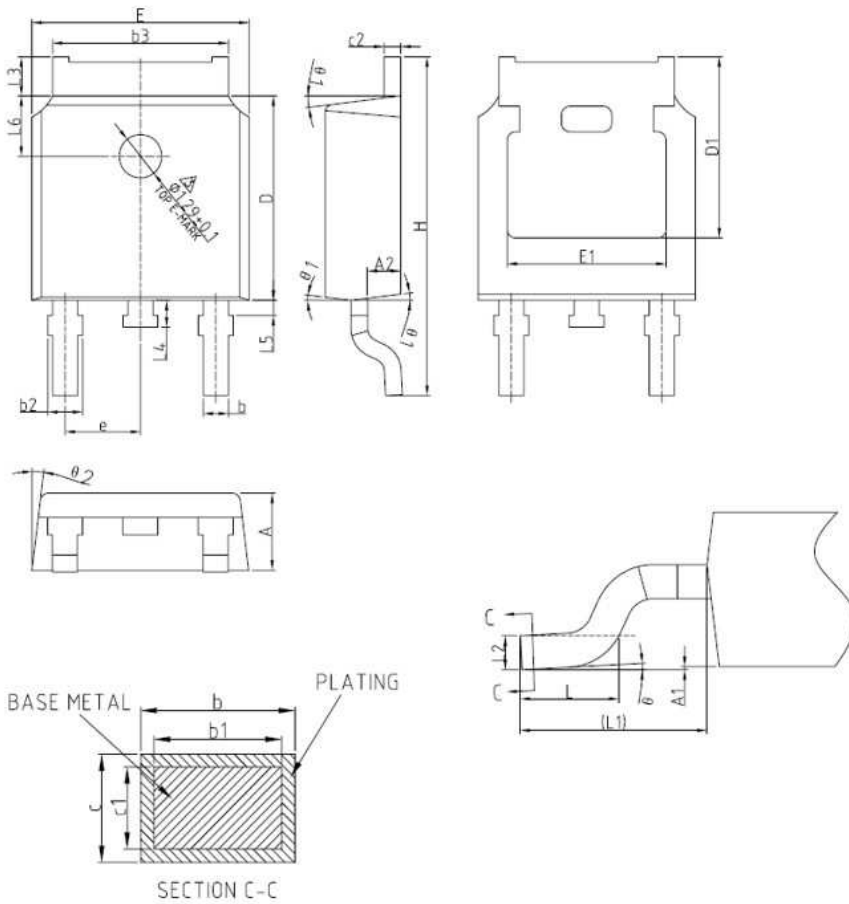

Fig. 6) Average Forward Current Characteristics



Package Outline Dimensions (Unit: mm)



COMMON DIMENSIONS
(UNITS OF MEASURE=MILLIMETER)

SYMBOL	MIN	NOM	MAX
A	2.20	2.30	2.38
A1	0	-	0.10
A2	0.90	1.01	1.10
b	0.72	-	0.85
b1	0.71	0.76	0.81
b2	0.72	-	0.90
b3	5.13	5.33	5.46
c	0.47	-	0.60
c1	0.46	0.51	0.56
c2	0.47	-	0.60
D	6.00	6.10	6.20
D1	5.25	-	-
E	6.50	6.60	6.70
E1	4.70	-	-
e	2.186	2.286	2.386
H	9.80	10.10	10.40
L	1.40	1.50	1.70
L1	2.90REF		
L2	0.51BSC		
L3	0.90	-	1.25
L4	0.60	0.80	1.00
L5	0.15	-	0.75
L6	1.80REF		
theta 1	0°	-	8°
theta 2	5°	7°	9°

XI Recommended Land Pattern (Unit: mm)

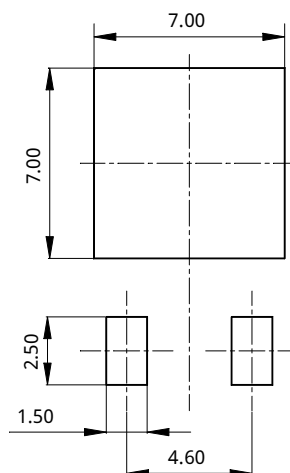

The AUK Corp. products are intended for the use as components in general electronic equipment (Office and communication equipment, measuring equipment, home appliance, etc.).

Please make sure that you consult with us before you use these AUK Corp. products in equipments which require high quality and / or reliability, and in equipments which could have major impact to the welfare of human life(atomic energy control, airplane, spaceship, transportation, combustion control, all types of safety device, etc.). AUK Corp. cannot accept liability to any damage which may occur in case these AUK Corp. products were used in the mentioned equipments without prior consultation with AUK Corp..

Specifications mentioned in this publication are subject to change without notice.