

Plug-in Signal Conditioners M-UNIT

LOGARITHM FUNCTION MODULE

Functions & Features

- Providing logarithm function output for a wide range of input signal
- Isolation up to 2000 V AC
- High-density mounting

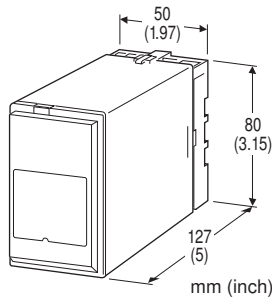

MODEL: MLG-[1][2]-[3][4]

ORDERING INFORMATION

- Code number: MLG-[1][2]-[3][4]
- Specify a code from below for each of [1] through [4].
(e.g. MLG-1A-B/Q)
- Special output range (For codes Z & 0)
 - Specify the specification for option code /Q
(e.g. /C01/S01)

[1] INPUT

Voltage

- 1: 100 mV - 10 V DC (Input resistance 100 k Ω min.)
- 2: 10 mV - 1 V DC (Input resistance 100 k Ω min.)

[2] OUTPUT

Current

- A: 4 - 20 mA DC (Load resistance 750 Ω max.)
 - B: 2 - 10 mA DC (Load resistance 1500 Ω max.)
 - C: 1 - 5 mA DC (Load resistance 3000 Ω max.)
 - D: 0 - 20 mA DC (Load resistance 750 Ω max.)
 - E: 0 - 16 mA DC (Load resistance 900 Ω max.)
 - F: 0 - 10 mA DC (Load resistance 1500 Ω max.)
 - G: 0 - 1 mA DC (Load resistance 15 k Ω max.)
- Z: Specify current (See OUTPUT SPECIFICATIONS)

Voltage

- 1: 0 - 10 mV DC (Load resistance 10 k Ω min.)
- 2: 0 - 100 mV DC (Load resistance 100 k Ω min.)
- 3: 0 - 1 V DC (Load resistance 1000 Ω min.)
- 4: 0 - 10 V DC (Load resistance 10 k Ω min.)
- 5: 0 - 5 V DC (Load resistance 5000 Ω min.)

- 6: 1 - 5 V DC (Load resistance 5000 Ω min.)
- 4W: -10 - +10 V DC (Load resistance 10 k Ω min.)
- 5W: -5 - +5 V DC (Load resistance 5000 Ω min.)
- 0: Specify voltage (See OUTPUT SPECIFICATIONS)

[3] POWER INPUT

AC Power

- B: 100 V AC
- C: 110 V AC
- D: 115 V AC
- F: 120 V AC
- G: 200 V AC
- H: 220 V AC
- J: 240 V AC

DC Power

- S: 12 V DC
- R: 24 V DC
- V: 48 V DC

[4] OPTIONS

- blank: none
/Q: With options (specify the specification)

SPECIFICATIONS OF OPTION: Q (multiple selections)

COATING (For the detail, refer to M-System's web site.)

- /C01: Silicone coating
/C02: Polyurethane coating
/C03: Rubber coating

TERMINAL SCREW MATERIAL

- /S01: Stainless steel

GENERAL SPECIFICATIONS

- Construction:** Plug-in
Connection: M3.5 screw terminals
Screw terminal: Chromated steel (standard) or stainless steel
Housing material: Flame-resistant resin (black)
Isolation: Input to output to power
Overrange output: Approx. -10 to +104 % at 1 - 5 V
Zero adjustment: -5 to +5 % (front)
Span adjustment: 95 to 105 % (front)

OUTPUT SPECIFICATIONS

- **DC Current:** 0 - 20 mA DC
- Minimum span:** 1 mA
- Offset:** Max. 1.5 times span
- Load resistance:** Output drive 15 V max.
- **DC Voltage:** -10 - +20 V DC
- Span:** Min. 5 mV, max. 20 V
- Offset:** Max. 1.5 times span

Load resistance: Output drive 1 mA max.; at ≥ 0.5 V

■ OPERATION DIAGRAM

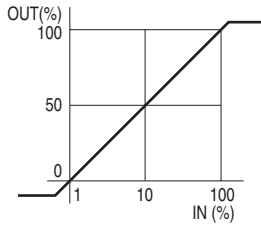

INSTALLATION

Power input

• **AC:** Operational voltage range: rating ± 10 %, 50/60 ± 2 Hz, approx. 3 VA

• **DC:** Operational voltage range: rating ± 10 %, ripple 10 %p-p max., approx. 2 W (90 mA at 24 V)

Operating temperature: -5 to +60°C (23 to 140°F)

Operating humidity: 30 to 90 %RH (non-condensing)

Mounting: Surface or DIN rail

Weight: 350 g (0.77 lb)

PERFORMANCE in percentage of span

Accuracy: ± 1.0 %

Temp. coefficient: ± 0.1 %/°C (± 0.06 %/°F)

Response time: ≤ 0.5 sec. (0 - 90 %)

Line voltage effect: ± 0.1 % over voltage range

Insulation resistance: ≥ 100 M Ω with 500 V DC

Dielectric strength: 2000 V AC @1 minute (input to output to power to ground)

EXTERNAL DIMENSIONS & TERMINAL ASSIGNMENTS unit: mm (inch)

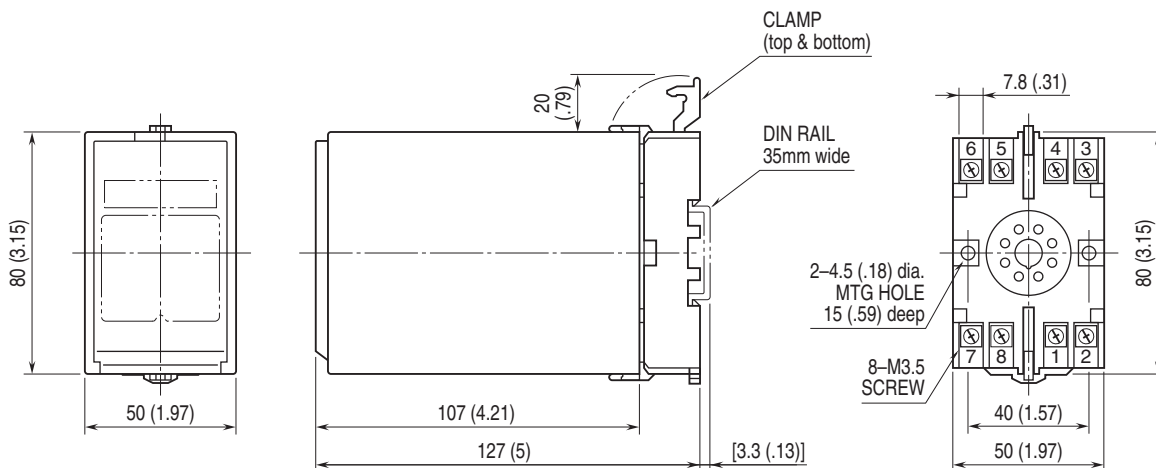

• When mounting, no extra space is needed between units.

SCHEMATIC CIRCUITRY & CONNECTION DIAGRAM

This unit is designed to amplify very low level signals by high gain. In order to prevent the output becomes unstable due to input noises, use shielded twisted-pair cables or take other precautions for input wiring.

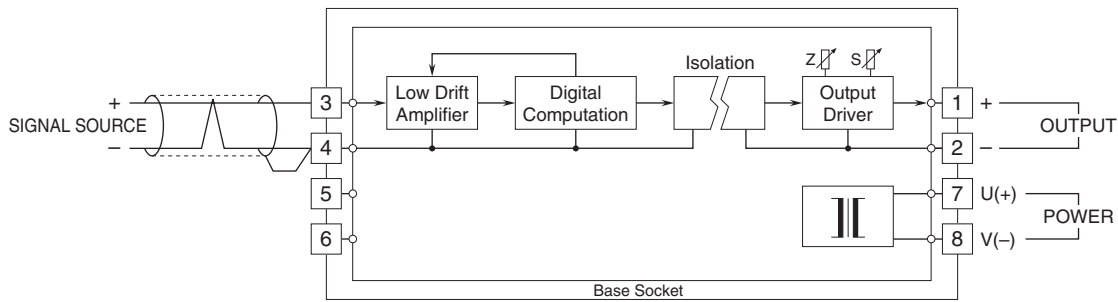

Specifications are subject to change without notice.