

LMH6518 900 MHz, Digitally Controlled, Variable Gain Amplifier

Check for Samples: [LMH6518](#)

FEATURES

- **Gain Range 40 dB**
- **Gain Step Size 2 dB**
- **Combined Gain Resolution with Gsample/Second ADC's 8.5 mdB**
- **Min Gain -1.16 dB**
- **Max Gain 38.8 dB**
- **-3 dB BW 900 MHz**
- **Rise/Fall Time <500 ps**
- **Recovery Time <5 ns**
- **Propagation Delay Variation 100 ps**
- **HD2 @ 100 MHz -50 dBc**
- **HD3 @ 100 MHz -53 dBc**
- **Input-Referred Noise (Max Gain) 0.98 nV/ $\sqrt{\text{Hz}}$**
- **Over-Voltage Clamps for Fast Recovery**
- **Power Consumption — Auxiliary Turned Off 1.1W0.75W**

APPLICATIONS

- **Oscilloscope Programmable Gain Amplifier**
- **Differential ADC Drivers**
- **High Frequency Single-Ended Input to Differential Conversion**
- **Precision Gain Control Applications**
- **Medical Applications**
- **RF/IF Applications**

DESCRIPTION

The LMH6518 is a digitally controlled variable gain amplifier whose total gain can be varied from -1.16 dB to 38.8 dB for a 40 dB range in 2 dB steps. The -3 dB bandwidth is 900 MHz at all gains. Gain accuracy at each setting is typically 0.1 dB. When used in conjunction with a National Semiconductor Gsample/second (Gsp/s) ADC with adjustable full scale (FS) range, the LMH6518 gain adjustment will accommodate full scale input signals from 6.8 mV_{PP} to 920 mV_{PP} to get 700 mV_{PP} nominal at the ADC input. The Auxiliary output (“+OUT Aux” and “-OUT Aux”) follows the Main output and is intended for use in Oscilloscope trigger function circuitry but may have other uses in other applications.

The LMH6518 gain is programmed via a SPI-1 compatible serial bus. A signal path combined gain resolution of 8.5 mdB can be achieved when the LMH6518's gain and the Gsp/s ADC's FS input are both manipulated. Inputs and outputs are DC-coupled. The outputs are differential with individual Common Mode (CM) voltage control (for Main and Auxiliary outputs) and have a selectable bandwidth limiting circuitry (common to both Main and Auxiliary) of 20, 100, 200, 350, 650, 750 MHz or full bandwidth.



Please be aware that an important notice concerning availability, standard warranty, and use in critical applications of Texas Instruments semiconductor products and disclaimers thereto appears at the end of this data sheet.

All trademarks are the property of their respective owners.

Functional Block Diagram

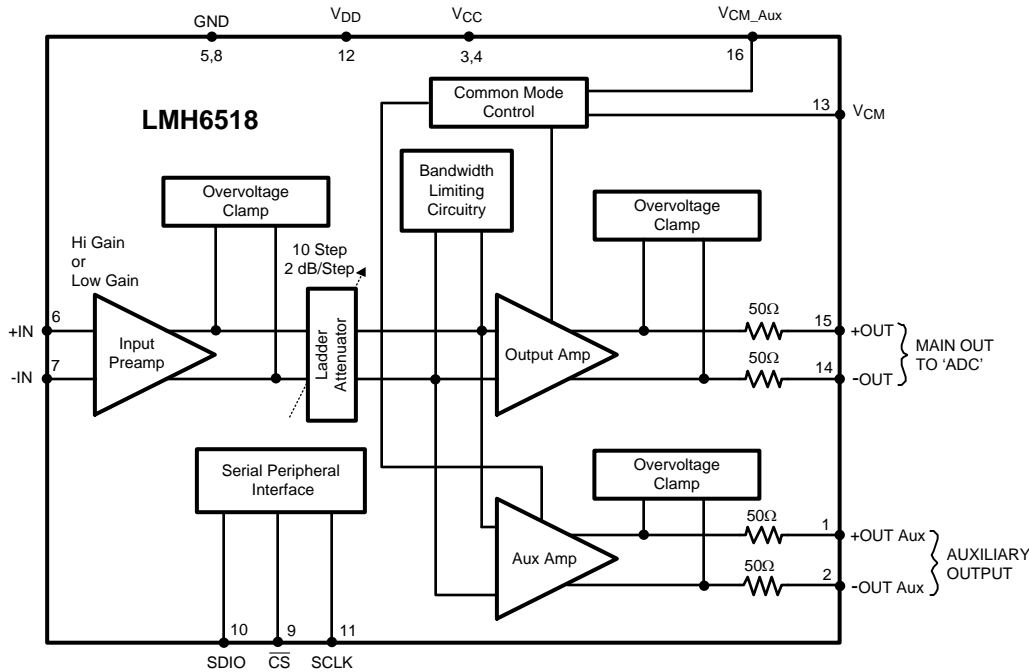

These devices have limited built-in ESD protection. The leads should be shorted together or the device placed in conductive foam during storage or handling to prevent electrostatic damage to the MOS gates.

Absolute Maximum Ratings ⁽¹⁾⁽²⁾

ESD Tolerance ⁽³⁾	
Human Body Model	2000V
Machine Model	200V
Charge Device Model	1000V
Supply Voltage	
V _{CC} (5V nominal)	5.5V
V _{DD} (3.3V nominal)	3.6V
Differential Input	±1V
Input Common Mode Voltage	1V to 4V
V _{CM} and V _{CM_Aux}	2V
SPI Inputs	3.6V
Maximum Junction Temperature	150°C
Storage Temperature Range	-65°C to 150°C
Soldering Information	
Infrared or Convection (20 sec.)	235°C
Wave Soldering (10 sec.)	260°C

- (1) Absolute Maximum Ratings indicate limits beyond which damage to the device may occur. Operating Ratings indicate conditions for which the device is intended to be functional, but specific performance is not guaranteed. For guaranteed specifications, see the Electrical Characteristics tables.
- (2) If Military/Aerospace specified devices are required, please contact the Texas Instruments Sales Office/Distributors for availability and specifications.
- (3) Human Body Model, applicable std. MIL-STD-883, Method 3015.7. Machine Model, applicable std. JESD22-A115-A (ESD MM std. of JEDEC) Field-Induced Charge-Device Model, applicable std. JESD22-C101-C (ESD FICDM std. of JEDEC).

Operating Ratings ⁽¹⁾

Supply Voltage	$V_{CC} = 5V (\pm 5\%)$ $V_{DD} = 3.3V (\pm 5\%)$
Temperature Range	-40°C to 85°C

- (1) Absolute Maximum Ratings indicate limits beyond which damage to the device may occur. Operating Ratings indicate conditions for which the device is intended to be functional, but specific performance is not guaranteed. For guaranteed specifications, see the Electrical Characteristics tables.

Thermal Properties

Temperature Range ⁽¹⁾	-40°C to 85°C
Junction-to-Ambient	
Thermal Resistance (θ_{JA}), WQFN ⁽¹⁾	40°C/W

- (1) The maximum power dissipation is a function of $T_{J(MAX)}$, θ_{JA} and T_A . The maximum allowable power dissipation at any ambient temperature is $P_D = (T_{J(MAX)} - T_A) / \theta_{JA}$. All numbers apply for package soldered directly into a 2 layer PC board with zero air flow. Package should be soldered onto a 6.8 mm² copper area as shown in the “recommended land pattern” shown in the package drawing.

Electrical Characteristics ⁽¹⁾

Unless otherwise specified, all limits are guaranteed for $T_A = 25^\circ\text{C}$, Input CM = 2.5V, $V_{CM} = 1.2V$, $V_{CM_Aux} = 1.2V$, Single-ended input drive, $V_{CC} = 5V$, $V_{DD} = 3.3V$, $R_L = 100\Omega$ differential (both Main & Auxiliary Outputs), $V_{OUT} = 0.7 V_{PP}$ differential (both Main & Auxiliary Outputs), both Main and Auxiliary Output Specifications, full bandwidth setting, gain = 18.8 dB (Preamp LG, 0 dB ladder attenuation), Full Power setting ⁽²⁾. [Electrical Characteristics Definition of Terms and Specifications](#) for abbreviations used in the datasheet. **Boldface** limits apply at the temperature extremes.

Symbol	Parameter	Condition	Min ⁽³⁾	Typ ⁽⁴⁾	Max ⁽³⁾	Units
Dynamic Performance						
LSBW	-3 dB Bandwidth	All Gains		900		MHz
Peaking	Peaking	All Gains		1		dB
GF_0.1 dB	± 0.1 dB Gain Flatness	All Gains		150		MHz
GF_1 dB	± 1 dB Gain Flatness	All Gains		400		MHz
TRS	Rise Time			460		ps
TRL	Fall Time			450		
OS	Overshoot	Main Output		9		%
t_{s_1}	Settling Time	Main Output, $\pm 0.5\%$		10		ns
t_{s_2}		Main Output, $\pm 0.05\%$		14		
$t_{recover}$	Recovery Time ⁽⁵⁾	All Gains		<5		ns
P_D	Propagation Delay	$V_{OUT} = 0.7 V_{PP}$, All Gains		1.2		ns
P_{D_VAR}	Propagation Delay Variation	Gain Varied		100		ps
Noise, Distortion, and RF Specifications						
e_{n_1}	Input Noise Spectral Density	Max Gain, 10 MHz		0.98		nV/ $\sqrt{\text{Hz}}$
e_{n_2}		Preamp LG and 0 dB Ladder, 10 MHz		4.1		
e_{no_1}	RMS Output Noise	Max Gain, 100 Hz to 400 MHz		1.7		mV
e_{no_2}		Preamp LG, 0 dB Ladder, 100 Hz to 400 MHz		940		μV

- (1) Electrical Table values apply only for factory testing conditions at the temperature indicated. Factory testing conditions result in very limited self-heating of the device such that $T_J = T_A$. No guarantee of parametric performance is indicated in the electrical tables under conditions of internal self-heating where $T_J > T_A$.
- (2) “Full Power” setting is with Auxiliary output turned on.
- (3) Limits are 100% production tested at 25°C unless otherwise specified. Limits over the operating temperature range are guaranteed through correlation using Statistical Quality Control (SQC) methods.
- (4) Typical values represent the most likely parametric norm as determined at the time of characterization. Actual typical values may vary over time and will also depend on the application and configuration. The typical values are not tested and are not guaranteed on shipped production material.
- (5) Recovery time” is the slower of the Main and Auxiliary outputs. Output swing of 700 mV_{PP} shifted up or down by 50% (0.35V) by introducing an offset. Measured values correspond to the time it takes to return to within $\pm 1\%$ of 0.7 V_{PP} (± 7 mV).

Electrical Characteristics ⁽¹⁾ (continued)

Unless otherwise specified, all limits are guaranteed for $T_A = 25^\circ\text{C}$, Input CM = 2.5V, $V_{CM} = 1.2\text{V}$, $V_{CM_Aux} = 1.2\text{V}$, Single-ended input drive, $V_{CC} = 5\text{V}$, $V_{DD} = 3.3\text{V}$, $R_L = 100\Omega$ differential (both Main & Auxiliary Outputs), $V_{OUT} = 0.7 V_{PP}$ differential (both Main & Auxiliary Outputs), both Main and Auxiliary Output Specifications, full bandwidth setting, gain = 18.8 dB (Preamp LG, 0 dB ladder attenuation), Full Power setting ⁽²⁾. [Electrical Characteristics Definition of Terms and Specifications](#) for abbreviations used in the datasheet. **Boldface** limits apply at the temperature extremes.

Symbol	Parameter	Condition	Min ⁽³⁾	Typ ⁽⁴⁾	Max ⁽³⁾	Units
NF_1	Noise Figure	Max Gain, $R_S = 50\Omega$ each Input, 10 MHz		3.8		dB
NF_2		Preamp LG, 0 dB Ladder, $R_S = 50\Omega$ each Input, 10 MHz		13.5		
HD2/ HD3_1	2 nd / 3 rd Harmonic Distortion ⁽⁶⁾	Main Output, 100 MHz, All Gains		-50/ -53		dBc
HD2/ HD3_2		Auxiliary Output, 100 MHz, All Gains		-48/ -50		
HD2/ HD3_3		Main Output, 250 MHz, All Gains		-44/ -50		
HD2/ HD3_4		Auxiliary Output, 250 MHz, All Gains		-42/ -42		
IMD3	Intermodulation Distortion ⁽⁶⁾	$f = 250\text{ MHz}$, Main output		-65		dBc
OIP3_1	Intermodulation Intercept ⁽⁶⁾	Main Output, 250 MHz		26		dBm
P_1dB_main	-1 dB Compression	Main Output, 250 MHz, 0 dB Ladder		1.8		V_{PP}
P_1dB_aux		Main Output, 250 MHz, 20 dB Ladder		1.0		
		Auxiliary Output, 250 MHz, 0 dB Ladder		1.65		
		Auxiliary Output, 250 MHz, 20 dB Ladder		1.0		
Gain Parameters						
$A_{V_DIFF_MAX}$	Max Gain		38.1	38.8	39.5	dB
$A_{V_DIFF_MIN}$	Min Gain		-1.91	-1.16	-0.40	dB
Gain_Step	Gain Step Size	All Gains including Preamp Step	1.8	2	2.2	dB
	Gain Step Size with ADC(See Applications Information)	ADC FS Adjusted		8.5		mdB
Gain_Range	Gain Range		39	40	41	dB
TC_{AV_DIFF}	Gain Temp Coefficient ⁽⁷⁾	All Gains		-0.8		mdB/ $^\circ\text{C}$
Gain_ACC	Absolute Gain Accuracy	Compared to theoretical from Max Gain in 2 dB steps	0.75	—	+0.75	dB
Matching						
Gain_match	Gain Matching Main/Auxiliary	All Gains		± 0.1	± 0.2	dB
BW_match	-3 dB Bandwidth Matching Main/Auxiliary	All Gains		5		%
RT_match	Rise Time Matching Main/ Auxiliary	All Gains		5		%
PD_match	Propagation Delay Matching Main/Auxiliary	All Gains		100		ps
Analog I/O						
CMRR_1	CM Rejection Ratio (see Table 1)	Preamp HG, 0 dB Ladder, $1.9\text{V} < \text{CMVR} < 3.1\text{V}$	45	86		dB
CMRR_2		Preamp LG, 0 dB Ladder, $1.9\text{V} < \text{CMVR} < 3.1\text{V}$	40	55		
CMVR_1	Input Common Mode Voltage Range	Preamp HG, All Ladder Steps, $\text{CMRR} \geq 45\text{ dB}$	1.9	—	3.1	V
CMVR_2		Preamp LG, All Ladder Steps, $\text{CMRR} \geq 40\text{ dB}$	1.9	—	3.1	
$ \Delta V_{O_CM} / \Delta I_{CM} $		All Gains, $2\text{V} < \text{CMVR} < 3\text{V}$	-60	-100		dB
CMRR_CM	CM Rejection Ratio relative to VCM (see Table 1)	Preamp LG, 0 dB		101		dB

(6) Distortion data taken under single ended input condition.

(7) Drift determined by dividing the change in parameter at temperature extremes by the total temperature change.

Electrical Characteristics ⁽¹⁾ (continued)

Unless otherwise specified, all limits are guaranteed for $T_A = 25^\circ\text{C}$, Input $\text{CM} = 2.5\text{V}$, $V_{\text{CM}} = 1.2\text{V}$, $V_{\text{CM_AUX}} = 1.2\text{V}$, Single-ended input drive, $V_{\text{CC}} = 5\text{V}$, $V_{\text{DD}} = 3.3\text{V}$, $R_L = 100\Omega$ differential (both Main & Auxiliary Outputs), $V_{\text{OUT}} = 0.7 V_{\text{PP}}$ differential (both Main & Auxiliary Outputs), both Main and Auxiliary Output Specifications, full bandwidth setting, gain = 18.8 dB (Preamp LG, 0 dB ladder attenuation), Full Power setting ⁽²⁾. [Electrical Characteristics Definition of Terms and Specifications](#) for abbreviations used in the datasheet. **Boldface** limits apply at the temperature extremes.

Symbol	Parameter	Condition	Min ⁽³⁾	Typ ⁽⁴⁾	Max ⁽³⁾	Units
$Z_{\text{in_diff}}$	Differential Input Impedance	All Gains		150 1.5		K Ω pF
$Z_{\text{in_CM}}$	CM Input impedance	Preamp HG		420 1.7		
		Preamp LG		900 1.7		
FS_{OUT1}	Full Scale Voltage Swing	Main Output, THD @ 100 MHz \leq -40 dBc, All Gains	770 ⁽⁸⁾	800		mV _{PP}
FS_{OUT2}		Main Output, Clamped, 0 dB Ladder		1800	1960	
FS_{OUT3}		Auxiliary Output, THD @ 100 MHz \leq -40 dBc All Gains	770 ⁽⁸⁾	800		
FS_{OUT4}		Auxiliary Output, Clamped, 0 dB Ladder		1600	1760	
$V_{\text{OUT_MAX1}}$	Voltage range at each output pin (clamped)	Main Output, All gains, $V_{\text{CM}} = 1.2\text{V}$	0.5		1.8	V
$V_{\text{OUT_MAX2}}$		Auxiliary Output, All Gains, $V_{\text{CM}} = 1.2\text{V}$	0.8		2.2	
$V_{\text{OUT_MAX3}}$		Main Output, All Gains, $V_{\text{CM}} = 1.45\text{V}$			2.05	
$V_{\text{OUT_MAX4}}$		Auxiliary output, All gains, $V_{\text{CM}} = 1.45\text{V}$			2.45	
$Z_{\text{OUT_DIFF}}$	Differential Output Impedance	All Gains	92	100	108	Ω
V_{OOS}	Output Offset Voltage	All Gains		± 15	± 40	mV
$V_{\text{OOS_shift1}}$	Output Offset Voltage Shift	Preamp LG to Preamp HG		13.7		mV
$V_{\text{OOS_shift2}}$		All Gains, Excluding Preamp Step		12.7		
TCV_{OOS}	Output Offset Voltage Drift ⁽⁹⁾	Preamp HG, 0 dB Ladder		-24		$\mu\text{V}/^\circ\text{C}$
		Preamp LG, 0 dB Ladder		-7		
I_B	Input Bias Current ⁽¹⁰⁾			+40	+100 +140	μA
V_{OCM}	Output CM Voltage Range	All Gains	0.95	1.20	1.45	V
$V_{\text{OS_CM}}$	Output CM Offset Voltage	All Gains		± 15	± 30	mV
$\text{TC}_{\text{VOS_CM}}$	CM Offset Voltage Temp Coefficient	All Gains		+55		$\mu\text{V}/^\circ\text{C}$
BAL_Error_DC	Output Gain Balance Error	DC, $\frac{\Delta V_{\text{O_CM}}}{\Delta V_{\text{OUT}}}$		-78		dB
BAL_Error_AC			250 MHz, $\frac{V_{\text{O_CM}}}{V_{\text{OUT}}}$		-45	
PB	Phase Balance Error (See Table 1)	250 MHz		± 0.8		deg
PSRR	Differential Power Supply Rejection(see Table 1)	Preamp HG, 0 dB Ladder	-60	-87		dB
		Preamp HG, 0 dB Ladder	-50	-70		
PSRR _{CM}	CM Power Supply Rejection(see Table 1)	Preamp LG, 0 dB	-55	-71		dB
$V_{\text{CM_I}}$	V_{CM} Input Bias Current ⁽¹⁰⁾	All Gains		± 1	± 10 ± 20	nA
$V_{\text{CM_AUX_I}}$	$V_{\text{CM_AUX}}$ Input Bias Current ⁽¹⁰⁾	All Gains		± 1	± 10 ± 20	

(8) Guaranteed by design.

(9) Drift determined by dividing the change in parameter at temperature extremes by the total temperature change.

(10) Positive current is current flowing into the device.

Electrical Characteristics ⁽¹⁾ (continued)

Unless otherwise specified, all limits are guaranteed for $T_A = 25^\circ\text{C}$, Input $\text{CM} = 2.5\text{V}$, $V_{\text{CM}} = 1.2\text{V}$, $V_{\text{CM_Aux}} = 1.2\text{V}$, Single-ended input drive, $V_{\text{CC}} = 5\text{V}$, $V_{\text{DD}} = 3.3\text{V}$, $R_L = 100\Omega$ differential (both Main & Auxiliary Outputs), $V_{\text{OUT}} = 0.7 V_{\text{PP}}$ differential (both Main & Auxiliary Outputs), both Main and Auxiliary Output Specifications, full bandwidth setting, gain = 18.8 dB (Preamp LG, 0 dB ladder attenuation), Full Power setting ⁽²⁾. [Electrical Characteristics Definition of Terms and Specifications](#) for abbreviations used in the datasheet. **Boldface** limits apply at the temperature extremes.

Symbol	Parameter	Condition	Min ⁽³⁾	Typ ⁽⁴⁾	Max ⁽³⁾	Units
Digital I/O & Timing						
V_{IH}	Input Logic High		$V_{\text{DD}}-0.6$			V
V_{IL}	Input Logic Low				0.5	V
V_{OH}	Output Logic High			V_{DD}		V
V_{OL}	Output Logic Low			0		V
$R_{\text{Hi_Z}}$	Output Resistance	High Impedance Mode		5		$\text{M}\Omega$
I_{in}	Input Bias Current			<1		μA
F_{SCLK}	SCLK Rate				10	MHz
$F_{\text{SCLK_DT}}$	SCLK Duty Cycle		45	50	55	%
T_{S}	SDIO Setup Time		25			ns
T_{H}	SDIO Hold Time		25			ns
T_{CES}	$\overline{\text{CS}}$ Enable Setup Time	From $\overline{\text{CS}}$ asserted to rising edge of SCLK	25			ns
t_{CDS}	$\overline{\text{CS}}$ Disable Setup Time	From $\overline{\text{CS}}$ de-asserted to rising edge of SCLK	25			ns
T_{IAG}	Inter-Access Gap		3			Cycles of SCLK
Power Requirements						
I_{S1}	Supply Current	V_{CC}	195	210	225 230	mA
$I_{\text{S1_off}}$		V_{CC} Aux off		150	165 170	
I_{DD}		V_{DD}			180	350 400
Bandwidth Limiting Filter Specifications						
Filter	Parameter	Condition	Min	Typ	Max	Units
20 MHz	Pass Band Tolerance (All Gains)	-3 dB Bandwidth		-0, +20		%
100 MHz	Pass Band Tolerance (All Gains)	-3 dB Bandwidth		-0, +20		%
200 MHz	Pass Band Tolerance (All Gains)	-3 dB Bandwidth		-0, +20		%
350 MHz	Pass Band Tolerance (Preamp LG, 0 dB Ladder)	-3 dB Bandwidth		± 10		%
	Pass Band Tolerance (All Gains)			± 25		
650 MHz	Pass Band Tolerance (Preamp LG, 0 dB Ladder)	-3 dB Bandwidth		± 10		%
	Pass Band Tolerance (All Gains)			± 25		
750 MHz	Pass Band Tolerance (Preamp LG, 0 dB Ladder)	-3 dB Bandwidth		± 10		%
	Pass Band Tolerance (All Gains)			± 25		

Table 1. Definition of Terms and Specifications

1.	A_{V_CM} (dB)	Change in output offset voltage (ΔV_{OOS}) with respect to the change in input common mode voltage (ΔV_{I_CM})
2.	A_{V_DIFF} (dB)	Gain with 100 Ω differential load
3.	CM	Common Mode
4.	CMRR (dB)	Common Mode rejection defined as: A_{V_DIFF} (dB) - A_{V_CM} (dB)
5.	CMRR_CM	Common Mode rejection relative to V_{CM} defined as: $\Delta V_{OOS} / \Delta V_{CM}$
6.	HG	Preamp High Gain
7.	Ladder	Ladder Attenuator setting (0-20 dB)
8.	LG	Preamp Low Gain
9.	Max Gain	Gain = 38.8 dB
10.	Min Gain	Gain = -1.16 dB
11.	+Out	Positive Main Output
12.	-Out	Negative Main Output
13.	+Out Aux	Positive Auxiliary Output
14.	-Out Aux	Negative Auxiliary Output
15.	PB	Phase Balance defined as the phase difference between the complimentary outputs relative to 180°
16.	PSRR	Input referred V_{OOS} shift divided by change in V_{CC}
17.	PSRR_CM	Output common mode voltage change (ΔV_{O_CM}) with respect to V_{CC} voltage change (ΔV_{CC})
18.	V_{CM}	Input pin voltage that sets Main output CM
19.	V_{CM_Aux}	Input pin voltage that sets Auxiliary output CM
20.	V_{I_CM}	Input CM voltage (average of +IN and -IN)
21.	ΔV_{IN} (V)	Differential voltage across device inputs
22.	V_{OOS}	DC offset voltage. Differential output voltage measured with inputs shorted together to $V_{CC}/2$
23.	V_{O_CM}	Output common mode voltage (DC average of V_{+OUT} and V_{-OUT})
24.	V_{OS_CM}	CM offset voltage: $V_{O_CM} - V_{CM}$
25.	ΔV_{O_CM}	Variation in output common mode voltage (V_{O_CM})
26.	$\frac{\Delta V_{O_CM}}{\Delta V_{OUT}}$	Balance Error. Measure of the output swing balance of "+OUT" and "-OUT", as reflected on the output common mode voltage (V_{O_CM}), relative to the differential output swing (V_{OUT}). Calculated as output common mode voltage change (ΔV_{O_CM}) divided by the output differential voltage change (ΔV_{OUT} , which is nominally around 700 mV _{PP})
27.	ΔV_{OUT}	Change in differential output voltage (Corrected for DC offset (V_{OOS}))

PIN OUT

Pin Out	Function
P1 = +OUT Aux	Auxiliary positive output
P2 = -OUT Aux	Auxiliary negative output
P3 = V _{CC} (5V)	Analog power supply
P4 = V _{CC} (5V)	Analog power supply
P5 = GND	Ground, electrically connected to the WQFN heat sink
P6 = +IN	Positive Input
P7 = -IN	Negative Input
P8 = GND	Ground, electrically connected to the WQFN heat sink
P9 = \overline{CS}	SPI interface, Chip Select, Active low
P10 = SDIO	SPI interface, Serial Data Input/Output
P11 = SCLK	SPI interface, Clock
P12 = V _{DD} (3.3V)	Digital power supply
P13 = V _{CM}	Input from ADC to control main output CM
P14 = -OUT	Main negative output
P15 = +OUT	Main positive output
P16 = V _{CM_Aux}	Input to control auxiliary output CM

Connection Diagram

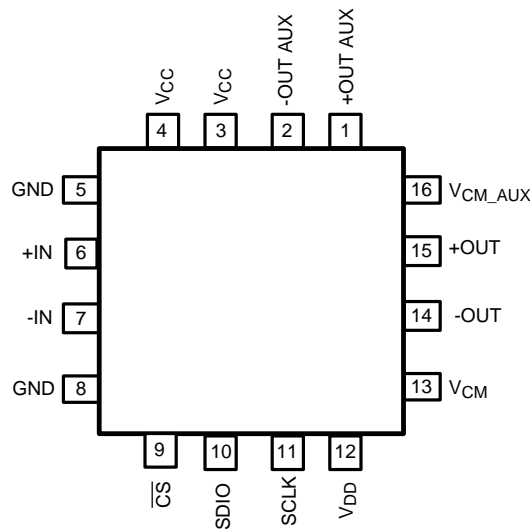

Figure 1. 16-Pin-Top View
See Package Number RGH0016A

Typical Performance Characteristics

Unless otherwise specified, Input CM = 2.5V, V_{CM} = 1.2V, V_{CM AUX} = 1.2V, Single-ended input drive, V_{CC} = 5V, V_{DD} = 3.3V, R_L = 100Ω differential (both Main & Auxiliary Outputs), V_{OUT} = 0.7 V_{PP} differential (both Main and Auxiliary Outputs), Main output specification (Auxiliary is labeled “Auxiliary”), full bandwidth setting, gain = 18.8 dB (Preamp LG, 0 dB ladder attenuation), Full Power setting ⁽¹⁾.

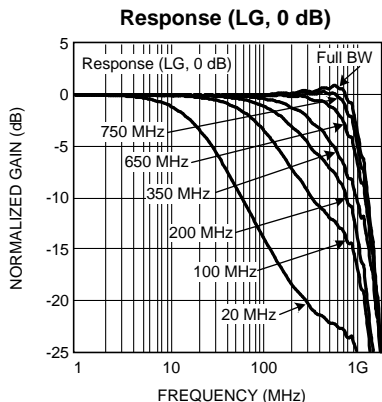

Figure 2.

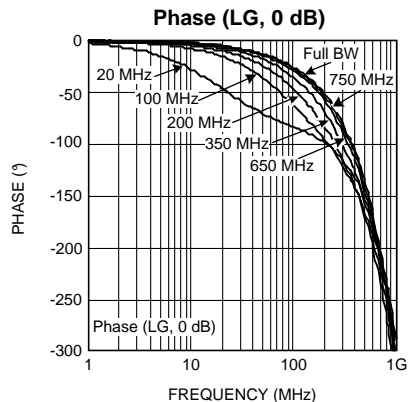

Figure 3.

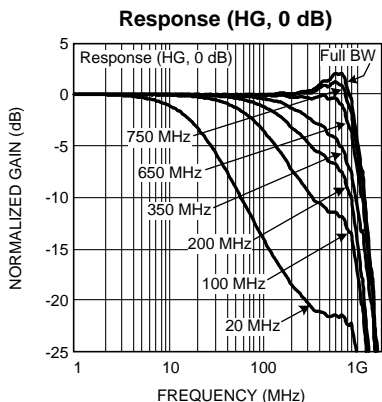

Figure 4.

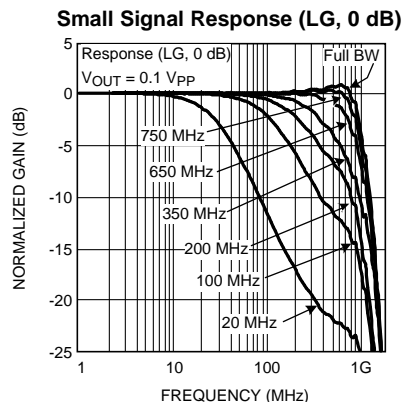

Figure 5.

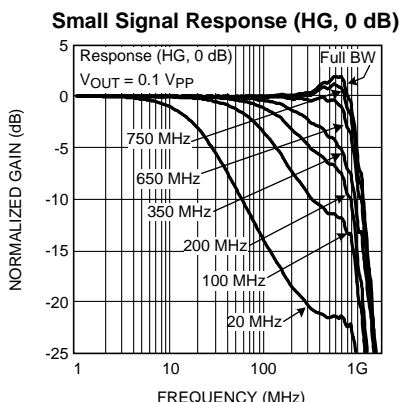

Figure 6.

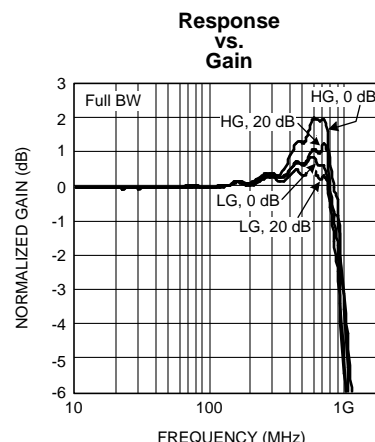

Figure 7.

(1) “Full Power” setting is with Auxiliary output turned on.

Typical Performance Characteristics (continued)

Unless otherwise specified, Input CM = 2.5V, V_{CM} = 1.2V, V_{CM AUX} = 1.2V, Single-ended input drive, V_{CC} = 5V, V_{DD} = 3.3V, R_L = 100Ω differential (both Main & Auxiliary Outputs), V_{OUT} = 0.7 V_{PP} differential (both Main and Auxiliary Outputs), Main output specification (Auxiliary is labeled “Auxiliary”), full bandwidth setting, gain = 18.8 dB (Preamp LG, 0 dB ladder attenuation), Full Power setting ⁽¹⁾.

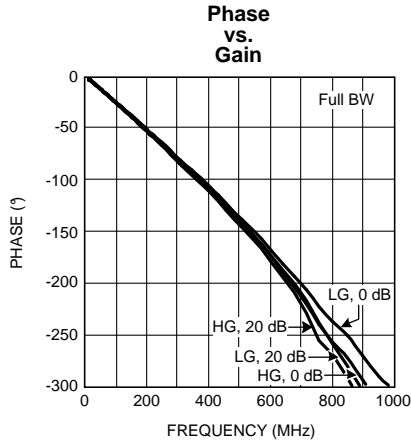

Figure 8.

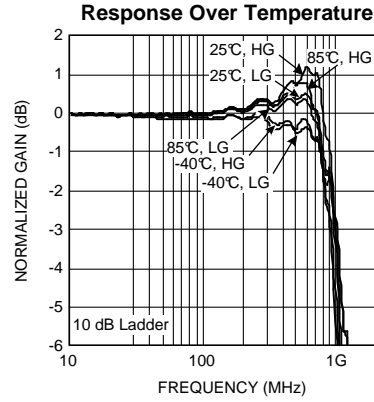

Figure 9.

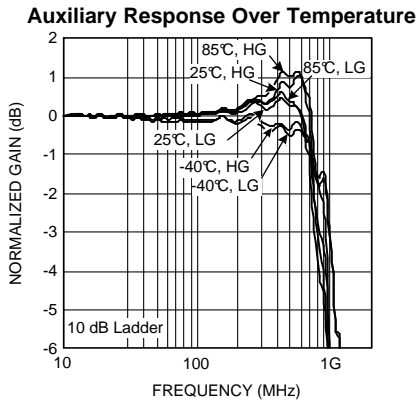

Figure 10.

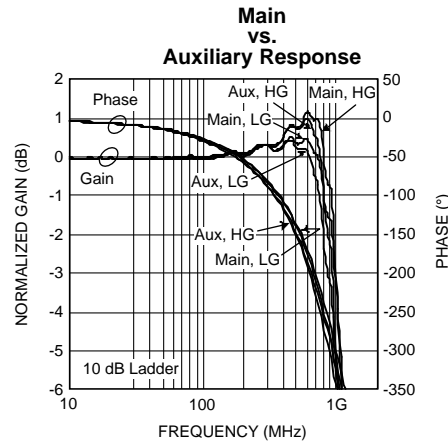

Figure 11.

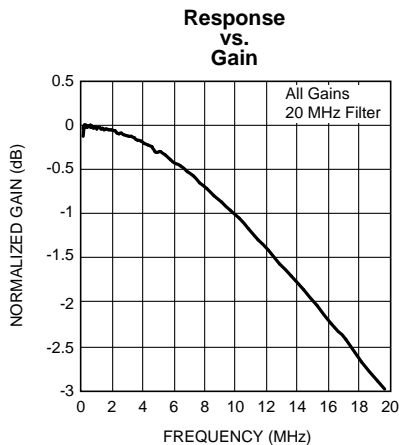

Figure 12.

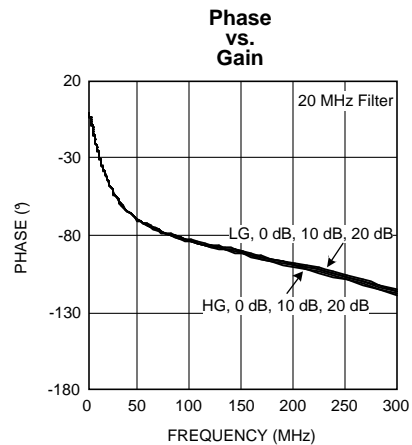

Figure 13.

Typical Performance Characteristics (continued)

Unless otherwise specified, Input CM = 2.5V, $V_{CM} = 1.2V$, $V_{CM\ AUX} = 1.2V$, Single-ended input drive, $V_{CC} = 5V$, $V_{DD} = 3.3V$, $R_L = 100\Omega$ differential (both Main & Auxiliary Outputs), $V_{OUT} = 0.7 V_{PP}$ differential (both Main and Auxiliary Outputs), Main output specification (Auxiliary is labeled "Auxiliary"), full bandwidth setting, gain = 18.8 dB (Preamp LG, 0 dB ladder attenuation), Full Power setting ⁽¹⁾.

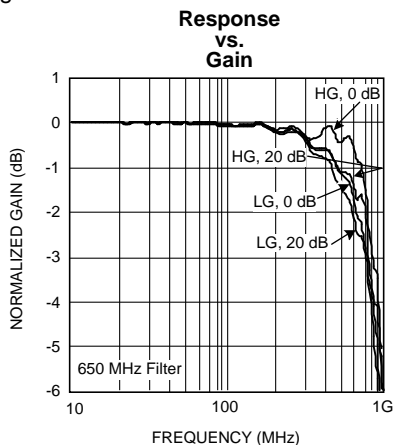

Figure 14.

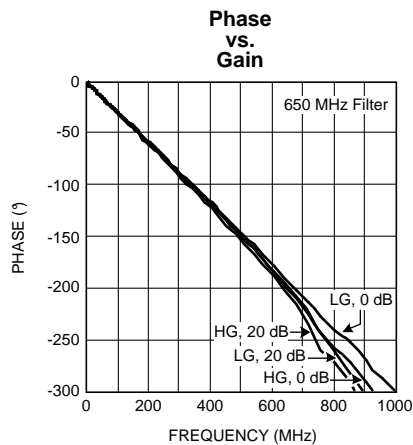

Figure 15.

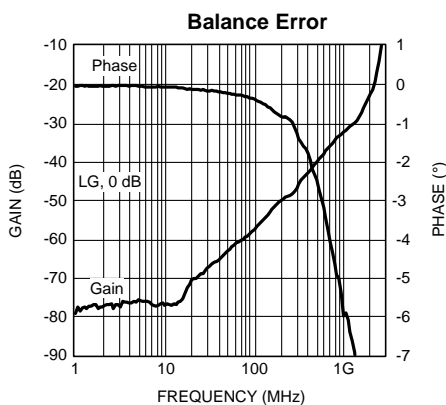

Figure 16.

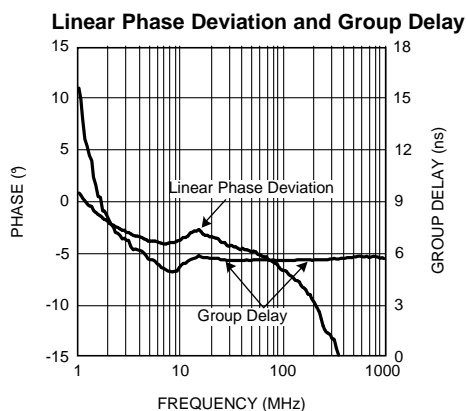

Figure 17.

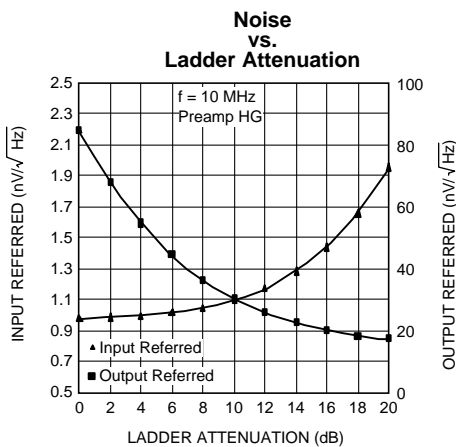

Figure 18.

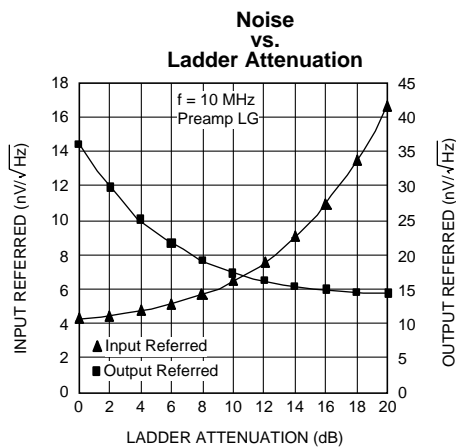

Figure 19.

Typical Performance Characteristics (continued)

Unless otherwise specified, Input CM = 2.5V, $V_{CM} = 1.2V$, $V_{CM\ AUX} = 1.2V$, Single-ended input drive, $V_{CC} = 5V$, $V_{DD} = 3.3V$, $R_L = 100\Omega$ differential (both Main & Auxiliary Outputs), $V_{OUT} = 0.7 V_{PP}$ differential (both Main and Auxiliary Outputs), Main output specification (Auxiliary is labeled "Auxiliary"), full bandwidth setting, gain = 18.8 dB (Preamp LG, 0 dB ladder attenuation), Full Power setting ⁽¹⁾.

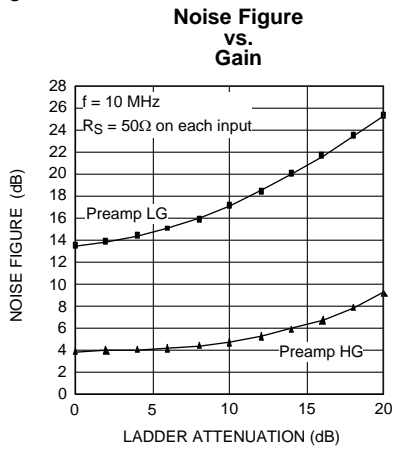

Figure 20.

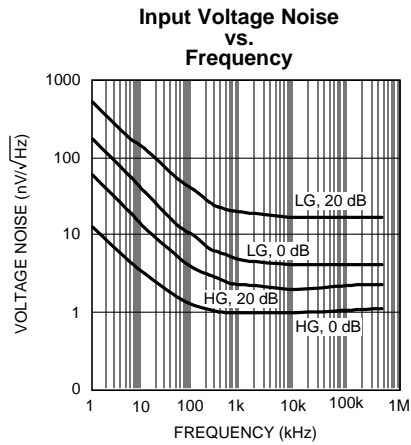

Figure 21.

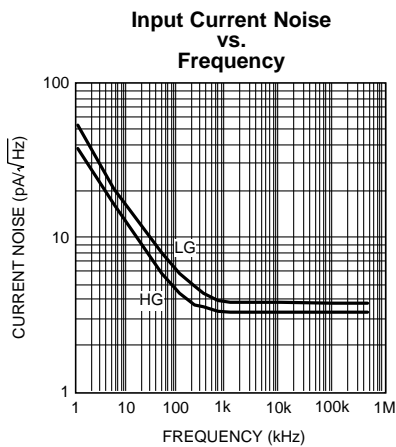

Figure 22.

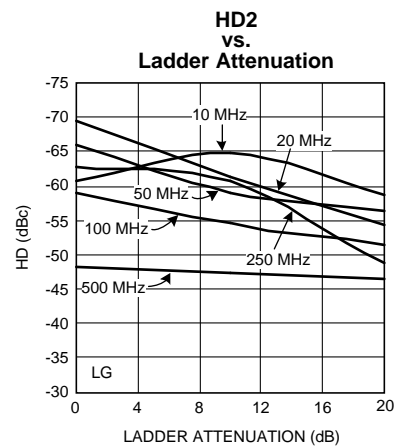

Figure 23.

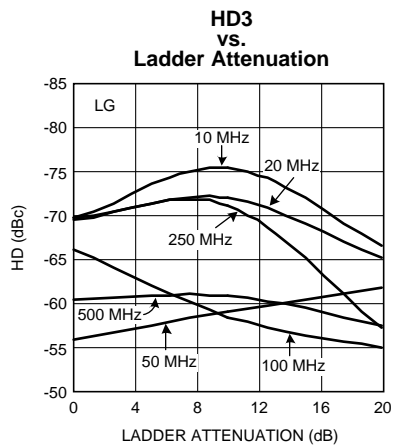

Figure 24.

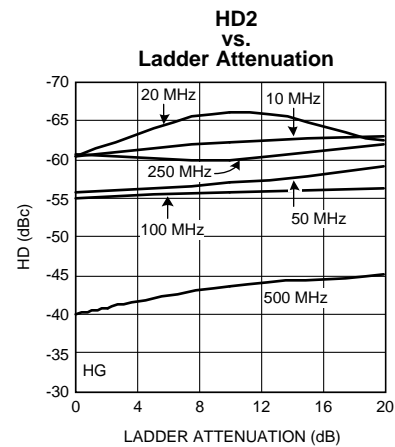

Figure 25.

Typical Performance Characteristics (continued)

Unless otherwise specified, Input CM = 2.5V, V_{CM} = 1.2V, V_{CM AUX} = 1.2V, Single-ended input drive, V_{CC} = 5V, V_{DD} = 3.3V, R_L = 100Ω differential (both Main & Auxiliary Outputs), V_{OUT} = 0.7 V_{PP} differential (both Main and Auxiliary Outputs), Main output specification (Auxiliary is labeled "Auxiliary"), full bandwidth setting, gain = 18.8 dB (Preamp LG, 0 dB ladder attenuation), Full Power setting ⁽¹⁾.

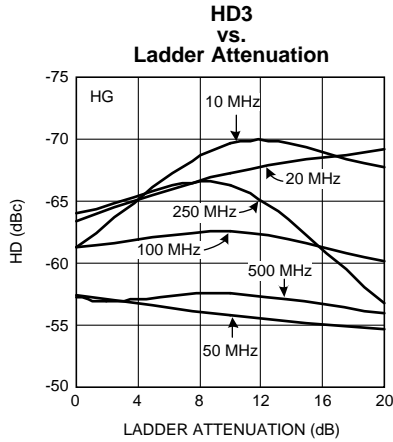

Figure 26.

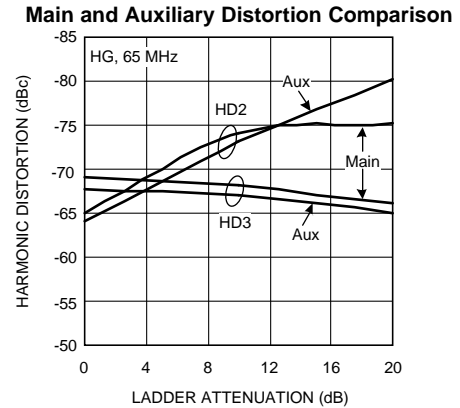

Figure 27.

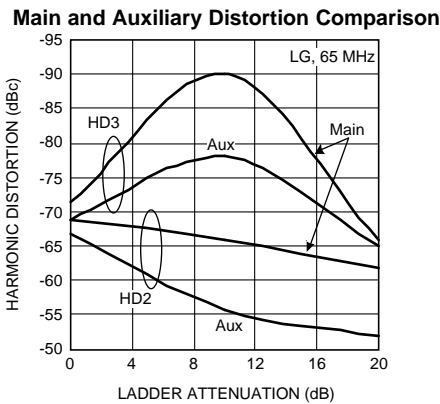

Figure 28.

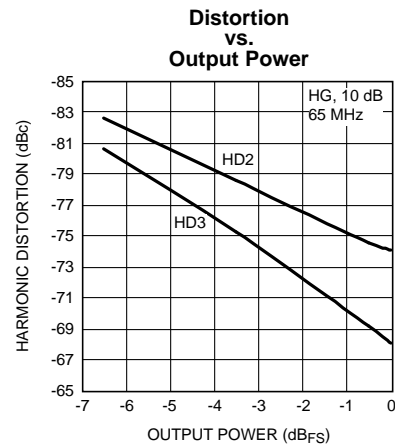

Figure 29.

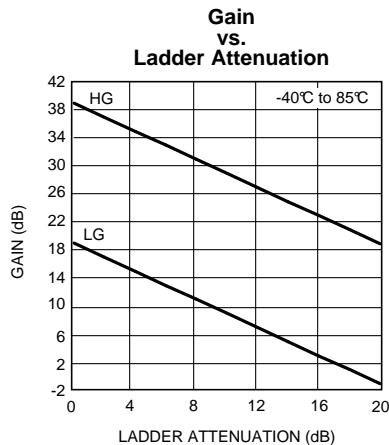

Figure 30.

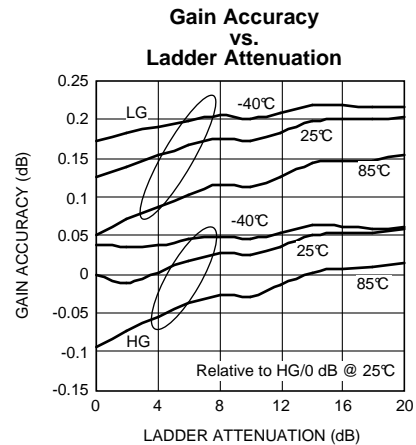

Figure 31.

Typical Performance Characteristics (continued)

Unless otherwise specified, Input CM = 2.5V, $V_{CM} = 1.2V$, $V_{CM\ AUX} = 1.2V$, Single-ended input drive, $V_{CC} = 5V$, $V_{DD} = 3.3V$, $R_L = 100\Omega$ differential (both Main & Auxiliary Outputs), $V_{OUT} = 0.7 V_{PP}$ differential (both Main and Auxiliary Outputs), Main output specification (Auxiliary is labeled "Auxiliary"), full bandwidth setting, gain = 18.8 dB (Preamp LG, 0 dB ladder attenuation), Full Power setting ⁽¹⁾.

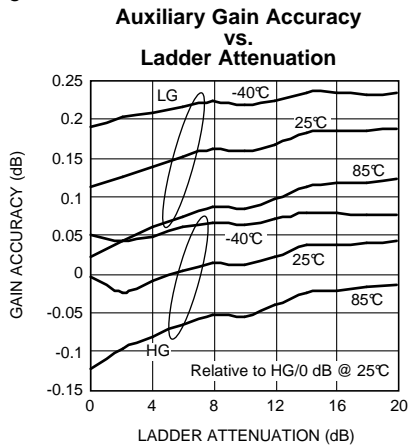

Figure 32.

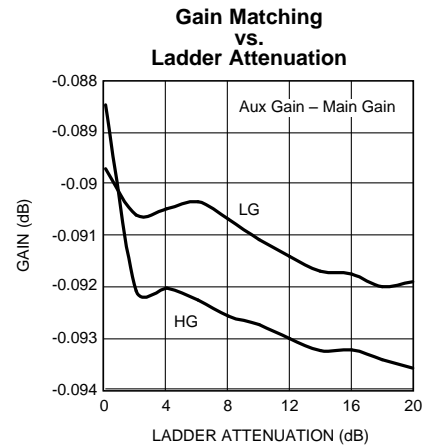

Figure 33.

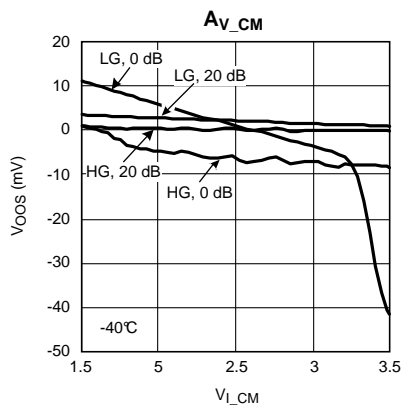

Figure 34.

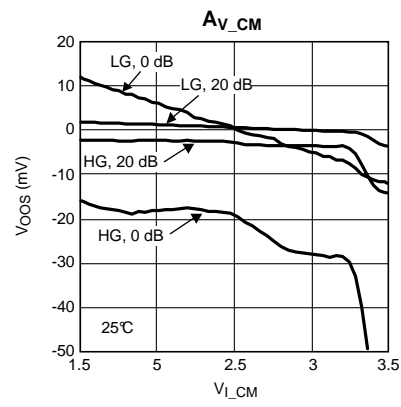

Figure 35.

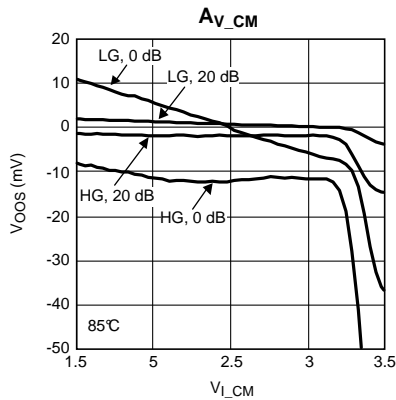

Figure 36.

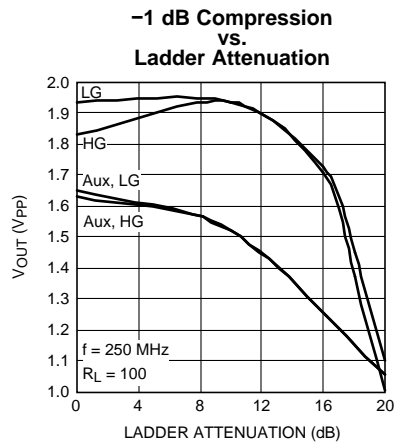

Figure 37.

Typical Performance Characteristics (continued)

Unless otherwise specified, Input CM = 2.5V, $V_{CM} = 1.2V$, $V_{CM\ AUX} = 1.2V$, Single-ended input drive, $V_{CC} = 5V$, $V_{DD} = 3.3V$, $R_L = 100\Omega$ differential (both Main & Auxiliary Outputs), $V_{OUT} = 0.7 V_{PP}$ differential (both Main and Auxiliary Outputs), Main output specification (Auxiliary is labeled "Auxiliary"), full bandwidth setting, gain = 18.8 dB (Preamp LG, 0 dB ladder attenuation), Full Power setting ⁽¹⁾.

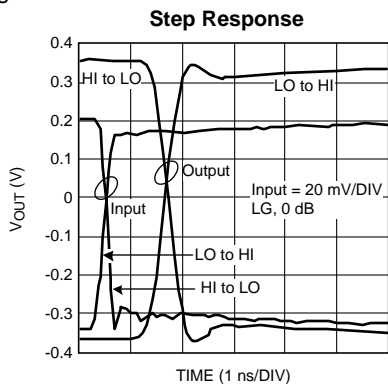

Figure 38.

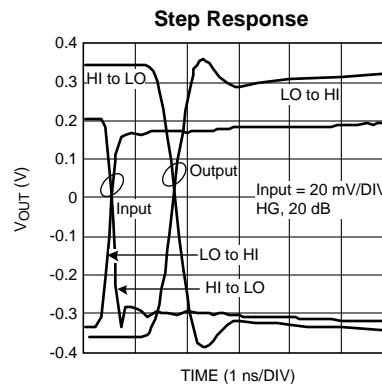

Figure 39.

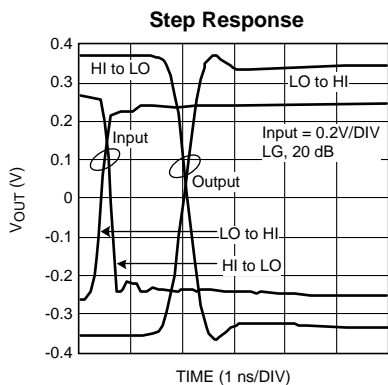

Figure 40.

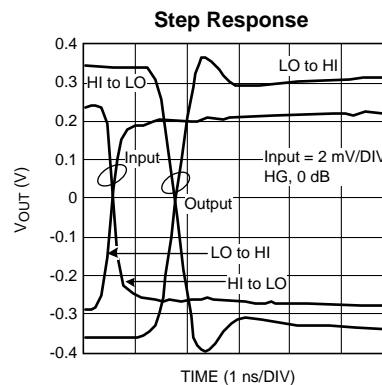

Figure 41.

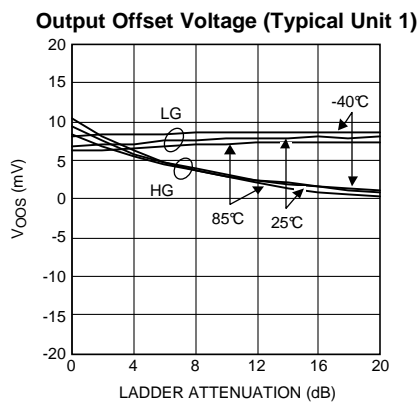

Figure 42.

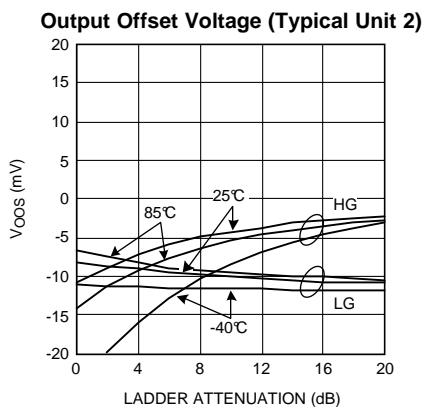

Figure 43.

Typical Performance Characteristics (continued)

Unless otherwise specified, Input CM = 2.5V, $V_{CM} = 1.2V$, $V_{CM_AUX} = 1.2V$, Single-ended input drive, $V_{CC} = 5V$, $V_{DD} = 3.3V$, $R_L = 100\Omega$ differential (both Main & Auxiliary Outputs), $V_{OUT} = 0.7 V_{PP}$ differential (both Main and Auxiliary Outputs), Main output specification (Auxiliary is labeled "Auxiliary"), full bandwidth setting, gain = 18.8 dB (Preamp LG, 0 dB ladder attenuation), Full Power setting ⁽¹⁾.

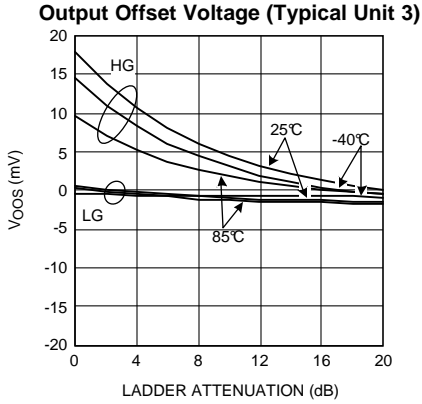

Figure 44.

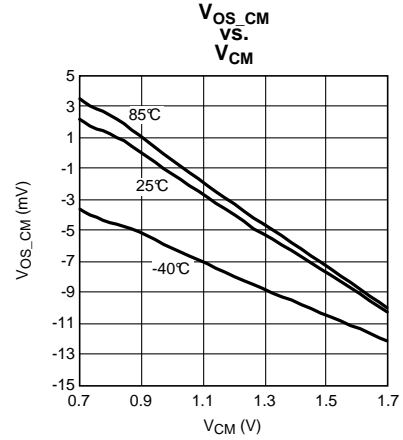

Figure 45.

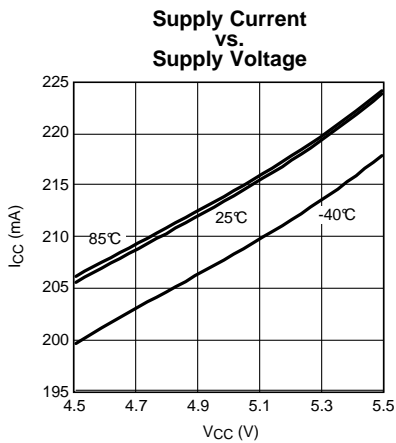

Figure 46.

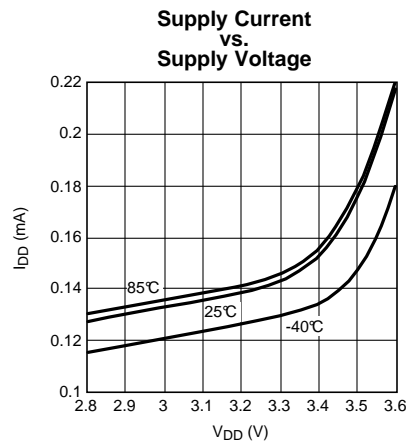

Figure 47.

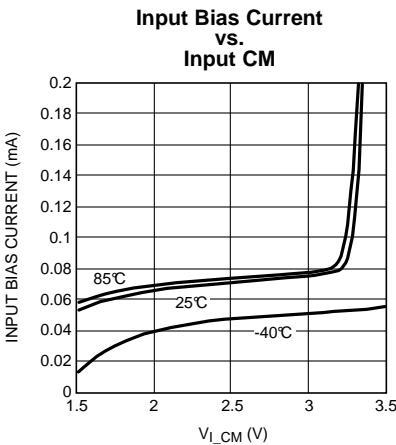

Figure 48.

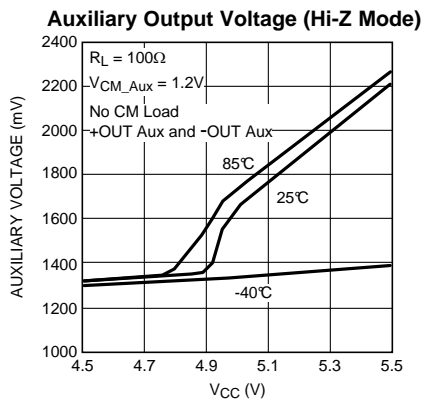

Figure 49.

Typical Performance Characteristics (continued)

Unless otherwise specified, Input CM = 2.5V, V_{CM} = 1.2V, V_{CM AUX} = 1.2V, Single-ended input drive, V_{CC} = 5V, V_{DD} = 3.3V, R_L = 100Ω differential (both Main & Auxiliary Outputs), V_{OUT} = 0.7 V_{PP} differential (both Main and Auxiliary Outputs), Main output specification (Auxiliary is labeled “Auxiliary”), full bandwidth setting, gain = 18.8 dB (Preamp LG, 0 dB ladder attenuation), Full Power setting ⁽¹⁾.

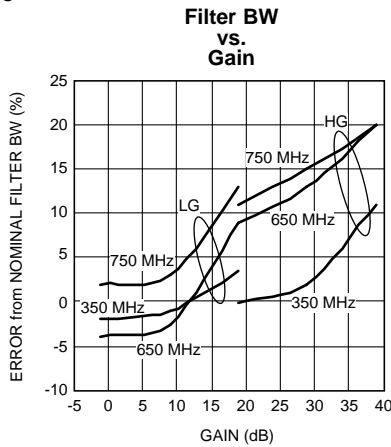

Figure 50.

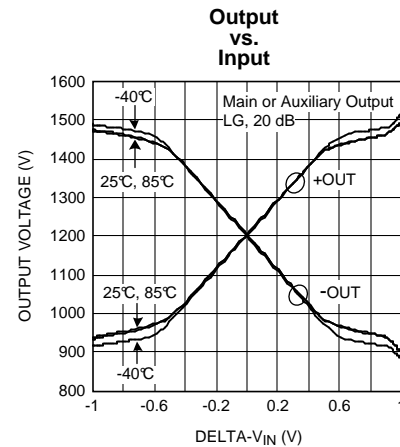

Figure 51.

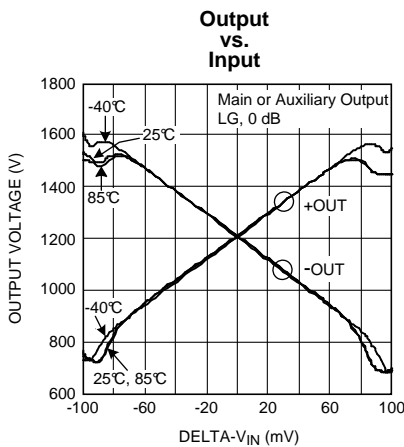

Figure 52.

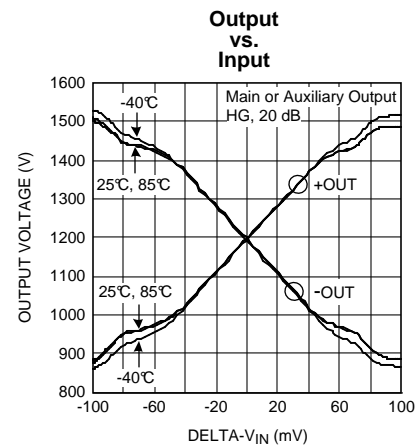

Figure 53.

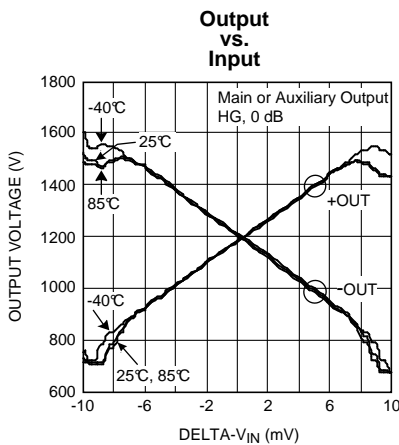

Figure 54.

Overdrive Recovery Time (Return to Zero)

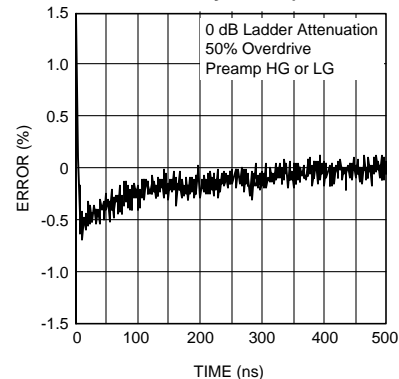

Figure 55.

Typical Performance Characteristics (continued)

Unless otherwise specified, Input CM = 2.5V, $V_{CM} = 1.2V$, $V_{CM\ AUX} = 1.2V$, Single-ended input drive, $V_{CC} = 5V$, $V_{DD} = 3.3V$, $R_L = 100\Omega$ differential (both Main & Auxiliary Outputs), $V_{OUT} = 0.7 V_{PP}$ differential (both Main and Auxiliary Outputs), Main output specification (Auxiliary is labeled "Auxiliary"), full bandwidth setting, gain = 18.8 dB (Preamp LG, 0 dB ladder attenuation), Full Power setting ⁽¹⁾.

Overdrive Recovery Time (Return to Zero)

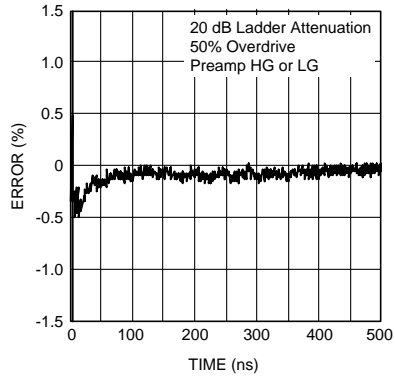

Figure 56.

APPLICATIONS INFORMATION

FUNCTIONAL DESCRIPTION AND DYNAMIC RANGE IN OSCILLOSCOPE APPLICATIONS

Here is a block diagram of the LMH6518's Main Output signal path:

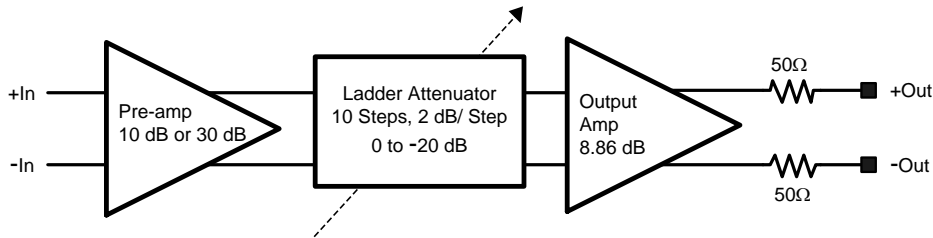

Figure 57. LMH6518 Signal Path Block Diagram

The Auxiliary output (not shown) uses another but similar Output Amp that taps into the Ladder Attenuator output. In this document, Preamp gain of 30 dB is referred to as “Preamp HG” (High Gain) and Preamp gain of 10 dB as “Preamp LG” (Low Gain).

The LMH6518's 2 dB/step gain resolution and 40 dB adjustment range (from -1.16 dB to 38.8 dB) allows this device to be used with the National GSample/second ADCs which have Full Scale, FS, adjustment (through their Extended Control Mode or ECM) to provide near-continuous variability (8.5 mdB resolution) to cover a 42.6 dB

$$(20 \times \log \frac{920 \text{ mV}_{PP}}{6.8 \text{ mV}_{PP}} = 42.6 \text{ dB}) \quad (1)$$

FS input range. The National Semiconductor GSample/second ECM control allows the ADC FS to be set using the ADC SPI bus. The ADC FS voltage range is from 560 mV to 840 mV with 9 bits of FS voltage control.

The ADC ECM gain resolution can be calculated as follows:

$$\text{Gain Resolution} = 20 \log \frac{0.56 + \left(\frac{0.84 - 0.56}{2 \times 512} \right)}{0.56 - \left(\frac{0.84 - 0.56}{2 \times 512} \right)} = 8.5 \text{ mdB} \quad (2)$$

The *recommended* ADC FS operating range is, however, narrower and it is from 595 mV to 805 mV with 700 mV_{PP} as the mid-point. Raising the value of ADC FS voltage is tantamount to reducing the signal path gain to accommodate a larger input and vice versa, thus providing a method of gain fine-adjust. The ADC ECM gain adjustment is -1.21 dB

$$\begin{aligned} & (= 20 \times \log \frac{700 \text{ mV}}{805 \text{ mV}}) \text{ to } +1.41 \text{ dB} \\ & (= 20 \times \log \frac{700 \text{ mV}}{595 \text{ mV}}) \end{aligned} \quad (3)$$

Because the ADC FS fine-adjust range of 2.62 dB (= 1.41 dB + 1.21 dB) is larger than the LMH6518's 2 dB/step resolution, there is always at least one LMH6518 gain setting to accommodate any FS signal from 6.8 mV_{PP} to 920 mV_{PP}, at the LMH6518 input, with 0.62 dB (= 2.62-2) overlap.

Assuming a nominal $0.7V_{PP}$ output, the LMH6518's minimum FS input swing is limited by the maximum signal path gain possible and vice versa:

$$\text{Minimum LMH6518 FS Input} = \frac{0.7 V_{PP}}{10^{\frac{(38.8 + 1.41) \text{ dB}}{20}}} = 6.8 \text{ mV}_{PP} \quad (4)$$

(or 8 mV_{PP} with no ADC fine adjust)

$$\text{Maximum LMH6518 FS Input} = \frac{0.7 V_{PP}}{10^{\frac{(-1.16 - 1.21) \text{ dB}}{20}}} = 920 \text{ mV}_{PP} \quad (5)$$

(or 800 mV_{PP} with no ADC FS adjust)

To accommodate a higher FS input, an additional attenuator is needed before the LMH6518. This front-end attenuator is shown in the [Figure 62](#) with its details shown in [Figure 71](#). The highest minimum attenuation level is determined by the largest FS input signal (FS_{max}):

$$\text{Attenuation (dB)} = 20 \times \log \frac{FS_{MAX} (V_{PP})}{800 \text{ mV}_{PP}} \quad (6)$$

So, to accommodate $80 V_{PP}$, 40 dB minimum attenuation is needed before the LMH6518.

In a typical oscilloscope application, the voltage range encountered is from $1 \text{ mV}/\text{DIV}$ to $10 \text{ V}/\text{DIV}$ with 8 vertical divisions visible on the screen. One of the primary concerns in a digital oscilloscope is SNR which translates to display trace width/ thickness. Typically, oscilloscope manufacturers need the noise level to be low enough so that the "no-input" visible trace width is less than 1% of FS. Experience has shown that this corresponds to a minimum SNR of 52 dB.

The factors that influence SNR are:

- Scope front end noise (Front-end attenuator + scope probe Hi-Z buffer which is discussed later in this document and shown in [Figure 62](#))
- LMH6518
- ADC

LMH6518 related SNR factors are:

- Bandwidth
- Preamp used (Preamp High Gain or Low Gain)
- Ladder Attenuation
- Signal level

SNR increases with the inverse square root of the bandwidth. So, reducing bandwidth from 450 MHz to 200 MHz, for example, improves SNR by 3.5 dB

$$\left(20 \times \log \frac{\sqrt{450 \text{ MHz}}}{\sqrt{200 \text{ MHz}}}\right) = 3.5 \text{ dB} \quad (7)$$

The other factors listed above, preamp and ladder attenuation, depend on the signal level and also impact SNR. The combined effect of these factors is summarized in [Figure 58](#) where SNR is plotted as a function of the LMH6518 FS input voltage (assuming scope bandwidth of 200 MHz) and not including the ADC and the front end noise:

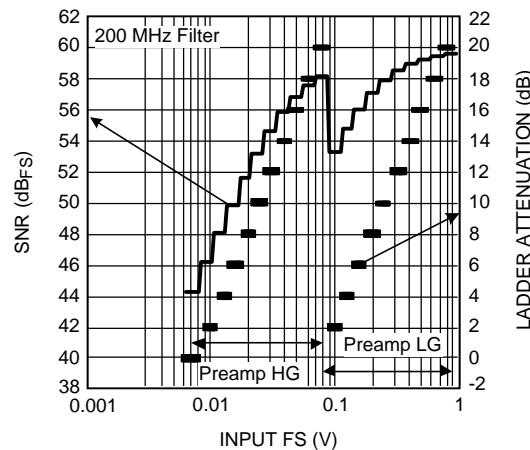

Figure 58. LMH6518 SNR & Ladder Attenuation used vs. Input

As can be seen from Figure 58, SNR of at least 52 dB is maintained for FS inputs above 24 mV_{PP} (3 mV/DIV on a scope) assuming the LMH6518's internal 200 MHz filter is enabled. Most oscilloscope manufacturers relax the SNR specifications to 40 dB for the highest gain (lowest scope voltage setting). From Figure 58, LMH6518's minimum SNR is 43.5 dB, thereby meeting the relaxed SNR specification for the lower range of scope front panel voltages.

In Figure 58, the step-change in SNR near Input FS of 90 mV_{PP} is the transition point from Preamp LG to Preamp HG with a subsequent 3 dB difference due to the Preamp HG/ 20 dB ladder attenuation's lower output noise compared to Preamp LG/ 2 dB ladder attenuation's noise. Judicious choice of front end attenuators can ensure that the 52 dB SNR specification is maintained for scope FS inputs ≥ 24 mV_{PP} by confining the LMH6518 gain range to the lower 30.5 dB

$$\left(= 20 \times \log \frac{0.8 V_{PP}}{24 mV_{PP}} \right) \tag{8}$$

from the total range of 40 dB (= 38.8 - (-1.16)) possible.

Here is an example:

To cover the range of 1 mV/DIV to 10 V/DIV (80 dB range), here is a configuration which affords good SNR:

Table 2. Oscilloscope Example Including Front-End Attenuators

Row	Scope FS Input (V _{PP})	"S", Scope Vertical Scale (V/DIV)	Preamp	Ladder Attenuation Range (dB)	"A", Front-end attenuation (V/V)	Minimum SNR (dB) with 200 MHz filter
1	8m-24m	1m-3m	HG	0-10	1	44
2	24m-80m	3m-10m	HG	10-20	1	52.0
3	80m-0.8	10m-0.1	LG	0-20	1	53.4
4	0.8-8	0.1-1	LG	0-20	10	53.4
5	8-80	1-10	LG	0-20	100	53.4

In Table 2, the highest FS input in Row 5, Column 2 (80 V_{PP}), and the LMH6518's highest FS input allowed (0.8 V_{PP}) set the

$$100x \left(= \frac{80 V_{PP}}{0.8 V_{PP}} \right) \tag{9}$$

front-end attenuator value. The 100x attenuator will allow high SNR operation to 30.5 dB down, as explained earlier, or 2.4 V_{PP} at scope input. In that same table, Rows 1-3 with no front-end attenuation (1x) cover the scope FS input range from 8 mV_{PP}-800 mV_{PP}. That leaves the scope FS input range of 0.8 V_{PP}-2.4 V_{PP}. If the 100x attenuator were used for the entire scope FS range of 0.8 V_{PP}-80 V_{PP}, SNR would dip below 52 dB for a portion of that range. Another attenuation level is thus required to maintain the SNR specification requirement of 52 dB.

One possible attenuation partitioning is to select the additional attenuator value to cover a 20 dB range above 0.8 V_{PP} FS (to 8 V_{PP}) with the 100x attenuator covering the remaining 20 dB range from 8 V_{PP} to 80 V_{PP} . Mapping 8 V_{PP} FS scope input to 0.8 V_{PP} at LMH6518 input means the additional attenuator is 10x, as shown in [Table 2](#), Row 4. The remaining scope input range of 8 V_{PP} -80 V_{PP} would then be covered by the 100x front-end attenuator derived earlier. The entire scope input range is now covered with SNR maintained about 52 dB for scope FS input ≥ 24 mV_{PP}, as shown in [Table 2](#).

SETTINGS AND ADC SPI CODE (ECM)

Covering the range from 1 mV/DIV to 10 V/DIV requires the following to be adjusted within the digital oscilloscope:

- Front-End Attenuator
- LMH6518 Preamp
- LMH6518 Ladder Attenuation
- ADC FS Value (ECM)

The LMH6518 Product Folder contains a spreadsheet which allows one to calculate the front-end attenuator, LMH6518 Preamp gain (HG or LG) and ladder attenuation, and ADC FS setting based on the scope vertical scale (S in V/DIV).

Here is the step by step procedure that explains the operations performed by the said spreadsheet based on the scope vertical scale setting (S in V/div) and front-end attenuation “A” (from [Table 2](#)). A numerical example is also worked out for more clarification:

1. Determine the required signal path gain, K:

$$K = 20 \times \log \frac{0.95 \times 700 \text{ mV}_{PP}}{8 \times S(\text{V/div})} = -21.6 + 20 \times \log \frac{A}{S(\text{V/div})} \quad (10)$$

assuming the full scale signal occupies 95% of the 0.7 V_{PP} FS (for 5% overhead) which occupies 8 vertical scope divisions).

Required condition: $-2.37 \text{ dB} \leq K \leq 40.3 \text{ dB}$

Example: With S = 110 mV/DIV, [Table 2](#) shows that A = 10 V/V:

$$\rightarrow K = -21.6 + 20 \times \log \frac{10}{110 \text{ mV}} = 17.57 \text{ dB} \quad (11)$$

2. Determine the LMH6518 gain, G:

- G is the closest LMH6518 gain, to the value of K where:
- $G = (38.8 - 2n)\text{dB}$; $n = 0, 1, 2, \dots, 20$
- For this example, the closest G to K = 17.57 dB is 16.8 dB (with $n = 11$). The next LMH6518 gain, 18.8 dB (with $n = 10$) would be incorrect as 16.8 is closer. If 18.8 dB were mistakenly chosen, the ADC FS setting would be out of range.
- Therefore: $G = 16.8 \text{ dB}$

3. Determine Preamp (HG or LG) & Ladder Attenuation:

- If $G \geq 18.8 \text{ dB} \rightarrow$ Preamp is HG and Ladder Attenuation = $38.8 - G$
- If $G < 18.8 \text{ dB} \rightarrow$ Preamp is LG and Ladder Attenuation = $18.8 - G$
- For this example, with $G = 16.8 \rightarrow$ Preamp LG and Ladder Attenuation = $2 \text{ dB} (= 18.8 - 16.8)$.

4. Determine the required ADC FS voltage, FS_E:

$$FS_E = \frac{S \times 8}{A} \times 1.05 \times 10^{\frac{\overset{\sim}{20}}{20}} \quad (12)$$

The “1.05” factor is to add 5% FS overhead margin to avoid ADC overdrive.

$$FS_E = \frac{S \times 8}{10} \times 1.05 \times 10^{\frac{16.8}{20}} = 639.3 \text{ mV} \quad (13)$$

Required condition: $0.56\text{V} \leq FS_E \leq 0.84\text{V}$

Recommend condition: $0.595\text{V} \leq FS_E \leq 0.805\text{V}$ for optimum ADC FS

5. Determine the ADC ECM code ratio:

$$\text{ECM (ratio)} = \frac{FS_E - 0.56}{0.28}$$

where

- $0.28\text{V} = (0.84 - 0.56)\text{V}$
- 0.56V is the lower end of the ADC FS adjustability
- For this example:

$$\text{ECM (ratio)} = \frac{0.6393 - 0.56}{0.28} = 0.283 \quad (14)$$

– Required condition: $0 \leq \text{ECM (ratio)} \leq 1$

6. Determine the ECM binary code to be sent on ADC SPI bus:

- Convert the ECM value represented by the ratio calculated above, to binary:
- $\text{ECM (binary)} = \text{DEC2BIN}\{\text{ECM(ratio)} * 511, 9\}$
- Where “DEC2BIN” is a spreadsheet function which converts the decimal ECM ratio, from step 5 above, multiplied by 511 distinct levels, into binary 9 bits.

NOTE

The Web based spreadsheet computes ECM without the use of “DEC2BIN” function to ease usage by all spreadsheet users who may not have this function installed.

- For this example: $\text{ECM (binary)} = \text{DEC2BIN}(0.283 * 511, 9) = 010010000$. This would be the number to be sent to the ADC on the SPI bus to program the ADC to the proper FS voltage.

INPUT/OUTPUT CONSIDERATIONS

The LMH6518’s ideal Input/Output Conditions, considered individually, are listed below:

Table 3. LMH6518’s Ideal Input/Output Conditions

Impedance from each input to ground (Ω)	Common Mode Input (V)	Differential Input (V_{PP})	Load Impedance (Ω)	Differential Output (V)	Common Mode Output (V)
≤ 50	1.5 to 3.1	< 0.8	100 (differential)/ 50 (single ended)	< 0.77	0.95-1.45

In addition to the individual conditions listed in [Table 3](#), the Input/Output terminal conditions should match differentially (i.e. +IN to –IN and +OUT to –OUT), as well, for best performance.

The input is differential but can be driven single-ended as long as the conditions of [Table 3](#) are met and there is good matching between the driven and the undriven inputs from DC to the highest frequency of interest. If not, there could be a settling time impact among other possible performance degradations. The datasheet specifications are with single-ended input, unless specified. Here is the recommended bench-test schematic to drive one input and to bias the other input with good matching in mind:

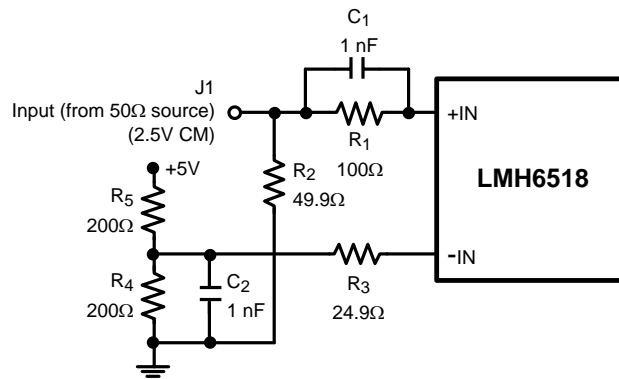

Figure 59. Recommended Single-Ended Bench-Test Input Drive from 50Ω Source

With the schematic of [Figure 59](#), each LMH6518 input sees 25Ω to ground at the higher frequencies when the capacitors look like shorts. This impedance increases to 125Ω at DC for both inputs, thereby preserving the required matching at any frequency. This configuration, using properly selected R's and C's, allows four times less biasing power dissipation than when the undriven input is biased with an effective 25Ω from the LMH6518 input to ground.

It is possible to drive the LMH6518 input from a ground referenced 50Ω source by providing level shift circuitry on the driven input. [Figure 60](#) shows a circuit where ½ the input signal reaches the LMH6518 input while the negative supply voltage (V_{EE}) ensures that the 50Ω source at J1 does not experience any biasing current while providing 50Ω termination to the source. The driven input (+IN) is biased to 2.5V ($V_{CC}/2$):

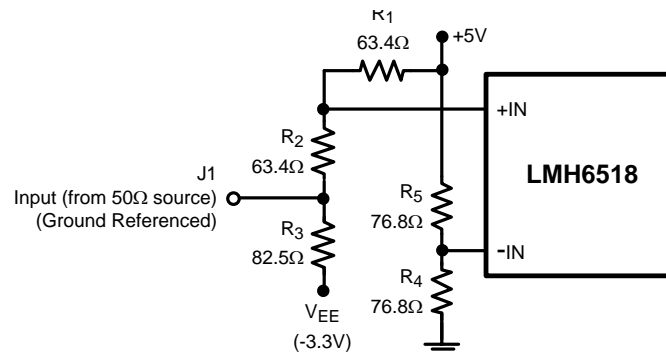

Figure 60. LMH6518 Driven by a Ground Referenced Source

In the schematic of [Figure 60](#), the equivalent impedance from each LMH6518 input to ground is around 38Ω. This configuration's power consumption of ~0.5W (in $R_1 - R_5$) is higher than that of [Figure 59](#) because of additional power dissipated to perform the level shifting. Additional 50Ω attenuators can be placed between J1 and R_2/R_3 junction in [Figure 60](#) in order to accommodate higher input voltages.

It is also possible to shift the LMH6518 *output* common mode level using a level shift approach similar to that of [Figure 60](#). The circuit in [Figure 61](#) shows an implementation where the LMH6518's nominal 1.2V CM output, set by a 1.2V on V_{CM} input from the Gsample/s ADC, is shifted lower for proper interface to different ADC's which require $V_{CM} = 0V$ and have high input impedance:

Here is a block diagram for how the LMH6518 is used in an oscilloscope:

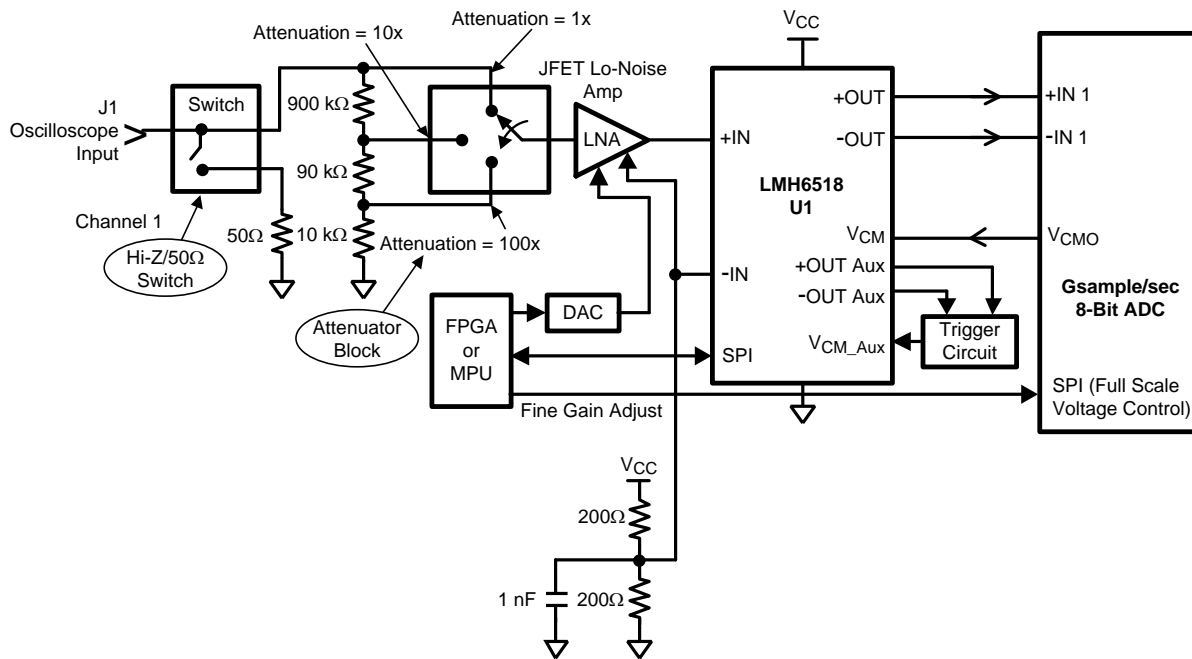

Figure 62. Digital Oscilloscope Front-End

From [Figure 62](#), the signal path consists of the input impedance switch, the attenuator switch, Low Noise Amplifier (LNA, JFET amplifier) to drive the LMH6518 input (+IN), and the DAC to provide offset adjust. The LNA must have the following characteristics:

- Set U1's common mode level to $V_{CC}/2$ (~2.5V)
- Very low drift (1 mV shift at LNA output could translate into 88 mV shift at LMH6518 output at max gain, or ~13% of FS).
- Low output impedance ($\leq 50\Omega$) to drive U1, for good settling behavior
- Low Noise ($<0.98 \text{ nV}/\sqrt{\text{Hz}}$) to reduce the impact on the LMH6518 Noise Figure. Note that [Figure 62](#) does not show the necessary capacitors across the resistors in the front-end attenuators (see [Figure 71](#)). These capacitors provide frequency response compensation and limit the noise contribution from the resistors so that they do not impact the signal path noise. For more information about front-end attenuator design, including frequency compensation, see [REFERENCE](#) for additional resources.
- Gain of 1 V/V (or very close to 1 V/V)
- Excellent frequency response flatness from DC to > 500-800 MHz to not impact the time domain performance

The undriven input (-IN) is biased to $V_{CC}/2$ using a voltage driver. The impedance driving the LMH6518's -IN should be closely matched to the LNA's output impedance for good settling time performance.

[APPENDIX A](#) shows one possible implementation of the LNA buffer along with performance data.

When the LMH6518's Auxiliary output is not used, it is possible to disable this output using SPI-1 (see [LOGIC FUNCTIONS](#) for SPI register map). [Electrical Characteristics](#) shows that by doing so, device power dissipation decreases by the reduction in supply current of about 60 mA. As can be seen in [Figure 63](#), in the absence of heavy common loading, the Auxiliary output will be at a voltage close to 1.7V ($V_{CC} = 5V$). With higher supply voltages, the Auxiliary voltage will also increase and it is important to make sure any circuitry tied to this output is capable of handling the 2.3V possible under V_{CC} worst case condition of 5.5V.

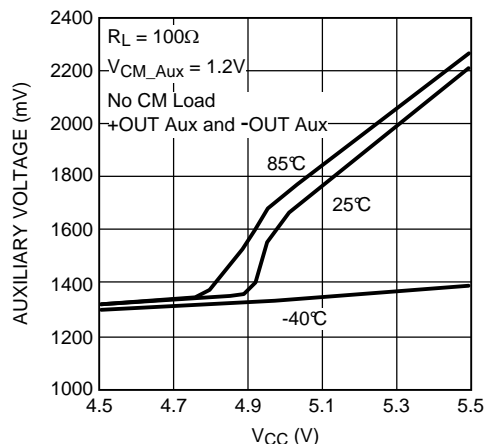

Figure 63. Auxiliary Output Voltage as a Function of V_{CC}

LOGIC FUNCTIONS

The following LMH6518 functions are controlled using the SPI-1 compatible bus:

- Filters (20, 100, 200, 350, 650, 750 MHz or full bandwidth)
- Power Mode (Full Power or Auxiliary Hi-Z (high impedance))
- Preamp (HG or LG)
- Attenuation Ladder (0-20 dB, 10 states)
- LMH6518 state “Write” or “Read” back

The SPI-1 bus uses 3.3V logic. “SDIO” is the serial digital input-output which can write to the LMH6518 or read back from it. “SCLK” is the bus clock with chip select function controlled by “CS”

SPI-1 PIN DESCRIPTIONS

Pin Name	Type	Function and Connection
\overline{CS}	Input	Serial Chip Select: While this signal is asserted SCLK is used to accept serial data present on SDIO and to source serial data on SDIO. When this signal is de-asserted, SDIO is ignored and SDIO is in TRI-STATE mode.
SCLK	Input	Serial Clock: Serial data are shifted into and out of the device synchronous with this clock signal. SCLK transitions with \overline{CS} de-asserted are ignored. SCLK to be stopped when not needed to minimize digital crosstalk.
SDIO	Input-Output	Serial Data-In or Data-out: Serial data are shifted into the device (8 bit Command and 16 bit Data) on this pin while \overline{CS} signal is asserted during Write operation. Serial data are shifted out of the device on this pin during a read operation while \overline{CS} signal is asserted. At other times, and after one complete Access Cycle (24 bits, see Figure 64 and Figure 65), this input is ignored. This output is in TRI-STATE mode when \overline{CS} is de-asserted. This pin is bi-directional.

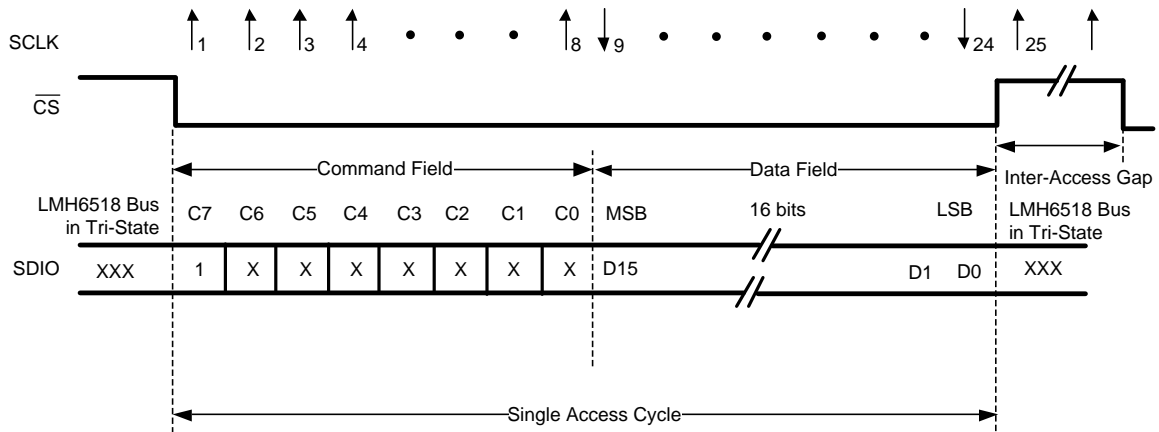

Figure 64. Serial Interface Protocol- Read Operation

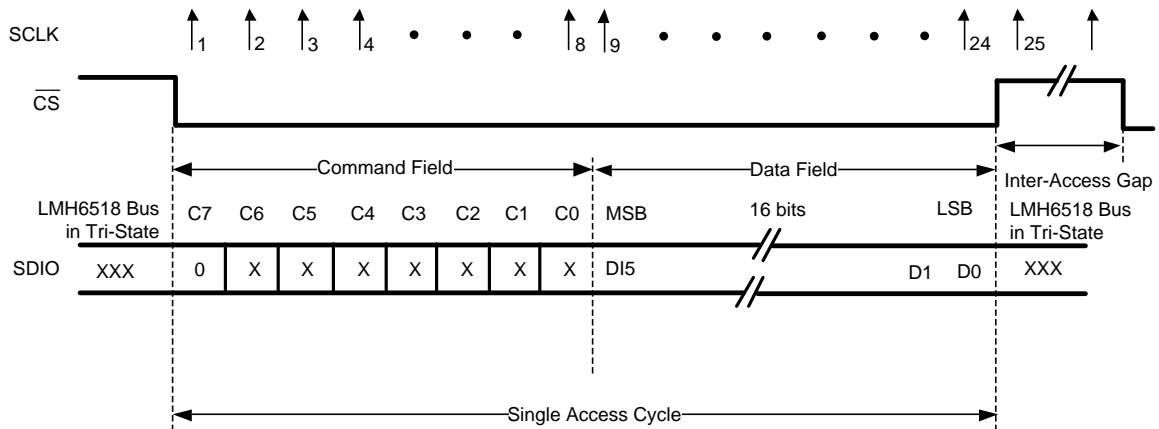

Figure 65. Serial Interface Protocol- Write Operation

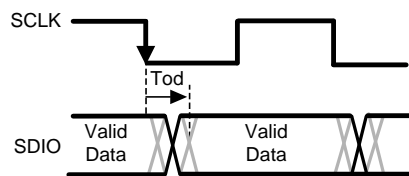

Figure 66. Read Timing

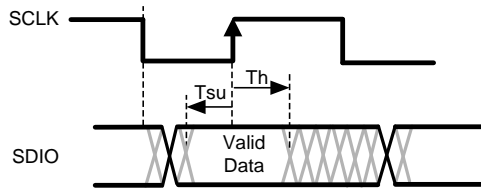

Figure 67. Write Timing

Table 4. Data Field

D15 (MSB)	D14	D13	D12	D11	D10	D9	Filter			D5	Pre-amp	Ladder Attenuation			
							D8	D7	D6		D4	D3	D2	D1	D0 (LSB)
X	0	0	0	0	0=Full Power 1=Aux Hi-Z	0	See Table 6			0	0=LG 1=HG	See Table 7			

NOTE

Bits D5, D9, D11-D14 must be "0". Otherwise, device operation is undefined and specifications are not guaranteed.

Table 5. Default Power-On Reset Condition

D15 (MSB)	D14	D13	D12	D11	D10	D9	Filter			D5	Pre-amp	Ladder Attenuation			
							D8	D7	D6		D4	D3	D2	D1	D0 (LSB)
0	0	0	0	0	0	0	0	0	0	0	0	1	0	1	0

Table 6. Filter Selection Data Field

Filter			Filter BW
D8	D7	D6	(MHz)
0	0	0	Full
0	0	1	20
0	1	0	100
0	1	1	200
1	0	0	350
1	0	1	650
1	1	0	750
1	1	1	Unallowed

NOTE

All filters are low pass single pole roll-off and operate on both Main and Auxiliary outputs. These filters are intended as signal path bandwidth and/ or noise limiting.

Table 7. Ladder Attenuation Data Field

Ladder Attenuation				Ladder Attenuation (dB)
D3	D2	D1	D0	
0	0	0	0	0
0	0	0	1	-2
0	0	1	0	-4
0	0	1	1	-6
0	1	0	0	-8
0	1	0	1	-10
0	1	1	0	-12
0	1	1	1	-14
1	0	0	0	-16
1	0	0	1	-18
1	0	1	0	-20
1	0	1	1	Unallowed
1	1	0	0	Unallowed
1	1	0	1	Unallowed
1	1	1	0	Unallowed

Table 7. Ladder Attenuation Data Field (continued)

Ladder Attenuation				Ladder Attenuation (dB)
1	1	1	1	Unallowed

NOTE

An “Unallowed” SPI-1 state may result in undefined operation where device behavior is not guaranteed.

OSCILLOSCOPE TRIGGER APPLICATIONS

With the Auxiliary output of the LMH6518 offering a second output that follows the Main one (except for a slightly reduced distortion performance), the oscilloscope trigger function can be implemented by tapping this output. The “V_{CM_Aux}” input of the LMH6518 allows the Auxiliary common mode to be set. The trigger function can be physically located at a distance from the main signal path, if need be, by taking advantage of the differential Auxiliary output and rejecting any board related common mode interference pick-up at the receive end.

If Trigger circuitry is physically close to the LMH6518, the circuit diagram shown in [Figure 68](#) allows operation using only one of two Auxiliary outputs. The unused output does need to be terminated properly using R₁, R₁₁ combination. U3 (DAC101C085) generates a 0- 2.5V trigger level, with 2.4 mV resolution

$$\left(= \frac{2.5V}{2^{10}} \right) \quad (15)$$

or 0.7% (= 2.4 mV x 100/0.35 V_{pp}) of FS, which is compared to the LMH6518 “+Out Aux” by using an ultra-fast comparator, U2 (LMH7220). U2’s complimentary LVDS output is terminated in the required 100Ω load (R₁₀), for best performance, where the LVDS Trigger output is available. The LMH7220’s offset voltage (±9.5 mV) and offset voltage drift (±50 μV/°C) error will be 5.9 LSB

$$\left(9.5 \text{ mV} + 50 \frac{\mu\text{V}}{^\circ\text{C}} \times 100^\circ\text{C} = 1.45 \text{ mV} \cong 5.9 \text{ LSB} \right) \quad (16)$$

of the Trigger DAC (U3). The offset voltage related portion of this error can be nulled-out, if necessary, during the oscilloscope initial calibration. To do so, the LMH6518 input is terminated properly with no input applied and U3 output is adjusted around V_{CM_Aux} voltage (1.2V ±10 mV) while looking for U2’s output transition. U3’s output, relative to V_{CM_Aux} at transition corresponds to U2’s offset error which can be factored into the Trigger readings and thus eliminated, leaving only the Offset voltage temperature drift component (= 2 LSB).

APPENDIX A

Here is the schematic drawing for a possible implementation of the LNA buffer shown in [Figure 62](#):

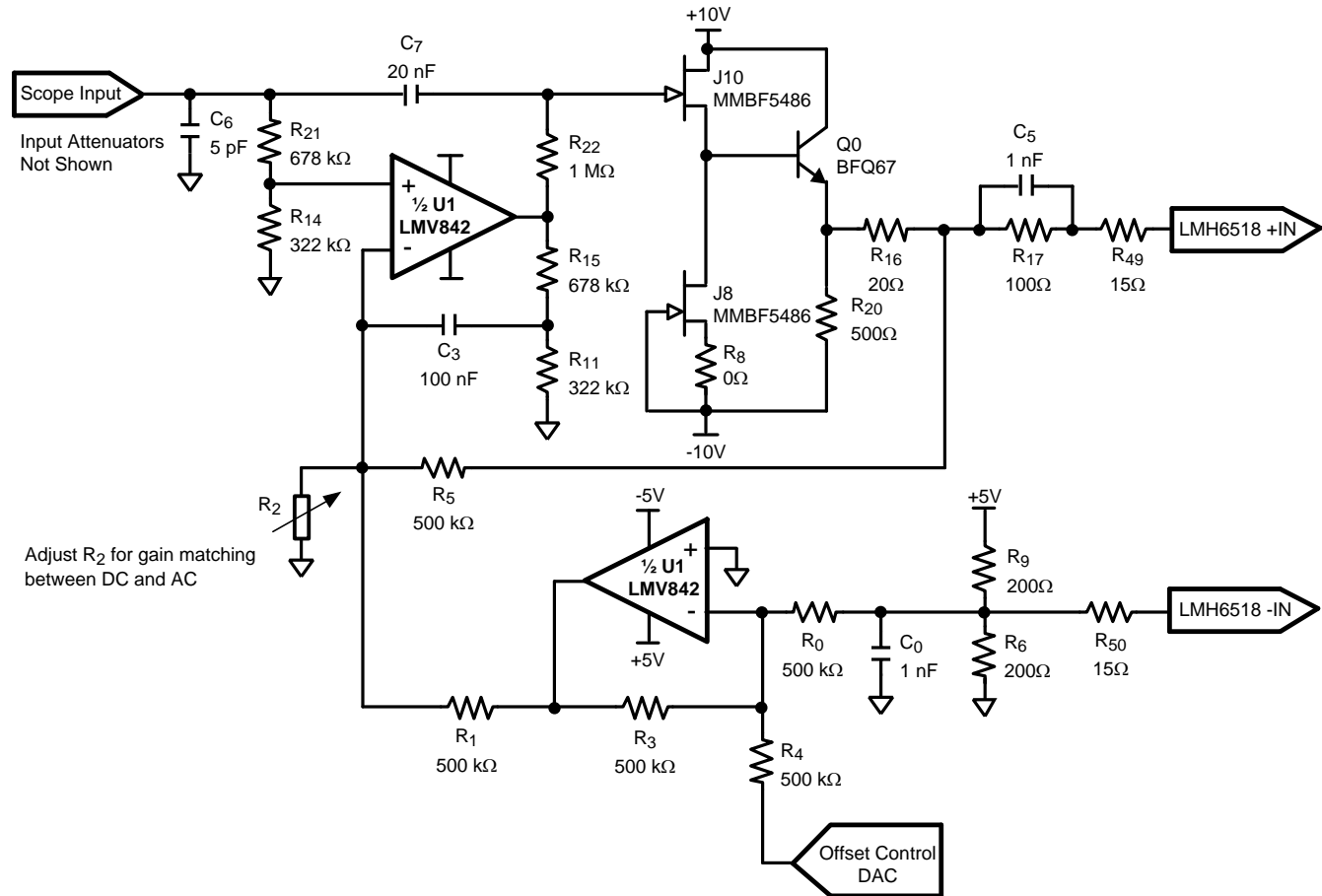

Figure 69. JFET LNA Implementation

CIRCUIT OPERATION

This circuit uses an N-Channel JFET (J10) in Source-Follower configuration, to buffer the input signal, with J8 acting as a constant current source. This buffer presents a fixed input impedance ($1\text{ M}\Omega \parallel 10\text{ pF}$) with a gain close to 1 V/V .

The signal path is AC coupled through C_7 with DC (and low frequency) at LMH6518 +IN maintained through the action of U1. NPN transistor Q0 is an emitter follower which isolates the buffer from the load (LMH6518 input and board traces).

The undriven input of the LMH6518, -IN, is biased to 2.5V by R_6 , R_9 voltage divider. The Lower $\frac{1}{2}$ of U1 inverts this voltage and the upper $\frac{1}{2}$ of U1 compares it to the combination of the driven output level at LMH6518 +IN and the scaled version of scope input at R_{14} , R_{21} junction, and adjusts J10 Gate accordingly to set the LMH6518 +IN. This control loop has a frequency response that covers DC to a few Hz, limited by the roll-off capacitor C_3 and R_{15} combination (1st order approximation). DC and low frequency gain is given by:

$$\text{Gain (DC)} = \frac{R_{14}}{R_{14} + R_{21}} \left(1 + \frac{R_5}{R_1 \parallel R_2} \right) \cong 1\text{ V/V}$$

(18)

With the values in [Figure 69](#) $\rightarrow R_2 \approx 452\text{ k}\Omega$:

For a flat frequency response, the DC (low frequency) gain needs to be lowered to match the less-than-1 V/V AC (high frequency) path gain through the JFETs. This can be done by increasing the value of R_2 .

By choosing the values of R_{15} and R_{11} so that

$$\frac{R_{21}}{R_{14}} = \frac{R_{15}}{R_{11}} \quad (19)$$

the frequency response at J10 Gate (and consequently the output) will remain flat when C_7 starts to conduct. Offset correction is done by varying the voltage at R_4 , using a DAC or equivalent as shown, in order to shift the LMH6518 +IN voltage relative to -IN. The result is a circuit which shifts the ground referenced scope input to 2.5V ($V_{CC}/2$) CM with adjustable offset and without any JFET or BJT related offsets.

Note that the front-end attenuator (not shown) lower leg resistance should be increased for proper divider-ratio to account for the 1 M Ω shunt due to the series combination of R_{21} and R_{14} . For example, a 10:1 front-end attenuator could be formed by a series 900 k Ω and a shunt 111 k Ω for a scope BNC input impedance of 1 M Ω (= 900K + (111K || 1M)).

Table 8 lists other possible JFET candidates that fall in the range of speed (f_t) and low noise needed:

Table 8. Suitable JFET Candidates Specifications

Company	Part Number	V_P (V)	I_{dss} (mA)	gm (mS)	Input C (pF)	noise ⁽¹⁾ (nV/ $\sqrt{\text{Hz}}$)	Break down (V)	Calculated f_t (MHz)
Interfet	IF140	-2.2	10	5.5	2.3	4	-20	380
Interfet	IF142	-2.2	10	5.5	2.3	4	-25	380
Interfet	2N5397/8	-2.5	13	8	5	2.5	-25	254
Interfet	2N5911/2	-2.5	13	8	5	2.5		254
Interfet	J308/9/10	-2.3	21	17	5.8		-25	466
Philips	BF513	-3	15	10	5			318
Fairchild	MMBF5486	-4	14	7	4	2.5	-25	278
Vishay Siliconix	SST441	-3.5	13	6	3.5	4	-35	272

(1) Noise data at $\sim I_{dss}/2$

The LNA noise could degrade the scope's SNR if it is comparable to the input referred noise of the LMH6518. LNA noise is influenced by the following operating conditions:

- JFET equivalent input noise
- BJT Base current

Reducing either "a" or "b" above, or both, reduces noise. One way to reduce "a" is to increase R_8 (currently set to 0 Ω). This will reduce the noise impact of J8 but requires a JFET which has a higher I_{dss} rating in order to maintain the operating current of J10 so that J10's noise contribution is minimized. Reducing the BJT Base current can be accomplished with increasing R_{20} at the expenses of higher rise/fall times. A higher β will also reduce the Base current (keep in mind that β and f_t at the operating Collector current is what matters).

Figure 70 shows the impact of the JFET buffer noise on SNR, compared to SNR in Figure 58, assuming either 3 nV/ $\sqrt{\text{Hz}}$ or 1.5 nV/ $\sqrt{\text{Hz}}$ buffer noise for comparison:

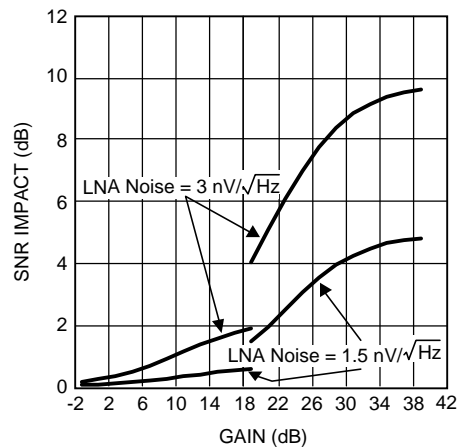

Figure 70. LNA Buffer SNR Impact

ATTENUATOR DESIGN

Figure 71 shows a front-end attenuator designed to work with the JFET LNA of Figure 69.

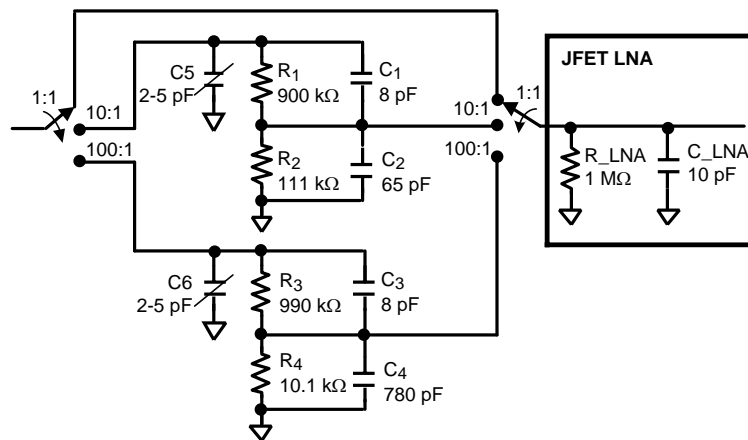

Figure 71. Front End Attenuator for Figure 69 JFET LNA

R_LNA” and “C_LNA” are the input impedance components of the JFET LNA. The 10:1 and 100:1 attenuators bottom resistors (R₂ and R₄) are adjusted higher to compensate for the LNA’s 1 MΩ input impedance, compared to the case where a high-input-impedance LNA is used. The two switches used on the input and output of the attenuator block must be low capacitance, high isolation switches in order to reduce any speed or crosstalk impact. C₁-C₄ provide the proper frequency response (and step response) by creating “zeros” that flatten the response for wide-band operation. For the 10:1 attenuator, R₁C₁ = R₂C₂. The same applies to the 100:1 attenuator. The shunt capacitors C₁-C₄ have a very important other benefit in that they roll-off the resistor thermal noise at a low frequency (low pass response, -3 dB down at ~20 kHz) thereby eliminating any significant noise contribution from the attenuation resistors. Otherwise, the channel noise would be dominated by the attenuator resistor thermal noise. C₂ and C₆ trimmer capacitors can be adjusted to match the input capacitance regardless of attenuator used.

REFERENCE

1. Wideband amplifiers by Peter Staric and Erik Margan, published by Springer in 2006. (Section 5.2).

PACKAGING INFORMATION

Orderable Device	Status (1)	Package Type	Package Drawing	Pins	Package Qty	Eco Plan (2)	Lead/Ball Finish	MSL Peak Temp (3)	Op Temp (°C)	Top-Side Markings (4)	Samples
LMH6518SQ/NOPB	ACTIVE	WQFN	RGH	16	1000	Green (RoHS & no Sb/Br)	CU SN	Level-3-260C-168 HR	-40 to 85	L6518SQ	Samples
LMH6518SQE/NOPB	ACTIVE	WQFN	RGH	16	250	Green (RoHS & no Sb/Br)	CU SN	Level-3-260C-168 HR	-40 to 85	L6518SQ	Samples
LMH6518SQX/NOPB	ACTIVE	WQFN	RGH	16	4500	Green (RoHS & no Sb/Br)	CU SN	Level-3-260C-168 HR	-40 to 85	L6518SQ	Samples

(1) The marketing status values are defined as follows:

ACTIVE: Product device recommended for new designs.

LIFEBUY: TI has announced that the device will be discontinued, and a lifetime-buy period is in effect.

NRND: Not recommended for new designs. Device is in production to support existing customers, but TI does not recommend using this part in a new design.

PREVIEW: Device has been announced but is not in production. Samples may or may not be available.

OBSOLETE: TI has discontinued the production of the device.

(2) Eco Plan - The planned eco-friendly classification: Pb-Free (RoHS), Pb-Free (RoHS Exempt), or Green (RoHS & no Sb/Br) - please check <http://www.ti.com/productcontent> for the latest availability information and additional product content details.

TBD: The Pb-Free/Green conversion plan has not been defined.

Pb-Free (RoHS): TI's terms "Lead-Free" or "Pb-Free" mean semiconductor products that are compatible with the current RoHS requirements for all 6 substances, including the requirement that lead not exceed 0.1% by weight in homogeneous materials. Where designed to be soldered at high temperatures, TI Pb-Free products are suitable for use in specified lead-free processes.

Pb-Free (RoHS Exempt): This component has a RoHS exemption for either 1) lead-based flip-chip solder bumps used between the die and package, or 2) lead-based die adhesive used between the die and leadframe. The component is otherwise considered Pb-Free (RoHS compatible) as defined above.

Green (RoHS & no Sb/Br): TI defines "Green" to mean Pb-Free (RoHS compatible), and free of Bromine (Br) and Antimony (Sb) based flame retardants (Br or Sb do not exceed 0.1% by weight in homogeneous material)

(3) MSL, Peak Temp. -- The Moisture Sensitivity Level rating according to the JEDEC industry standard classifications, and peak solder temperature.

(4) Only one of markings shown within the brackets will appear on the physical device.

Important Information and Disclaimer: The information provided on this page represents TI's knowledge and belief as of the date that it is provided. TI bases its knowledge and belief on information provided by third parties, and makes no representation or warranty as to the accuracy of such information. Efforts are underway to better integrate information from third parties. TI has taken and continues to take reasonable steps to provide representative and accurate information but may not have conducted destructive testing or chemical analysis on incoming materials and chemicals. TI and TI suppliers consider certain information to be proprietary, and thus CAS numbers and other limited information may not be available for release.

In no event shall TI's liability arising out of such information exceed the total purchase price of the TI part(s) at issue in this document sold by TI to Customer on an annual basis.

TAPE AND REEL INFORMATION

QUADRANT ASSIGNMENTS FOR PIN 1 ORIENTATION IN TAPE

*All dimensions are nominal

Device	Package Type	Package Drawing	Pins	SPQ	Reel Diameter (mm)	Reel Width W1 (mm)	A0 (mm)	B0 (mm)	K0 (mm)	P1 (mm)	W (mm)	Pin1 Quadrant
LMH6518SQ/NOPB	WQFN	RGH	16	1000	178.0	12.4	4.3	4.3	1.3	8.0	12.0	Q1
LMH6518SQE/NOPB	WQFN	RGH	16	250	178.0	12.4	4.3	4.3	1.3	8.0	12.0	Q1
LMH6518SQX/NOPB	WQFN	RGH	16	4500	330.0	12.4	4.3	4.3	1.3	8.0	12.0	Q1

TAPE AND REEL BOX DIMENSIONS

*All dimensions are nominal

Device	Package Type	Package Drawing	Pins	SPQ	Length (mm)	Width (mm)	Height (mm)
LMH6518SQ/NOPB	WQFN	RGH	16	1000	203.0	190.0	41.0
LMH6518SQE/NOPB	WQFN	RGH	16	250	203.0	190.0	41.0
LMH6518SQX/NOPB	WQFN	RGH	16	4500	358.0	343.0	63.0

RGH0016A

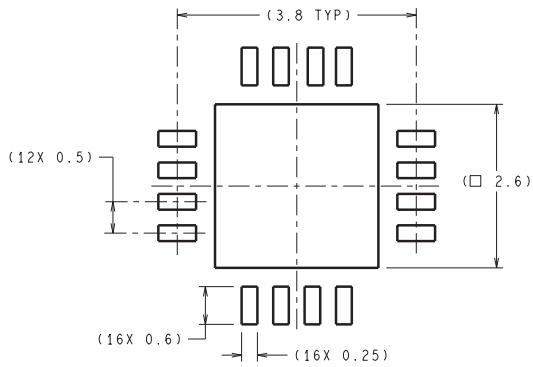

DIMENSIONS ARE IN MILLIMETERS
DIMENSIONS IN () FOR REFERENCE ONLY

RECOMMENDED LAND PATTERN

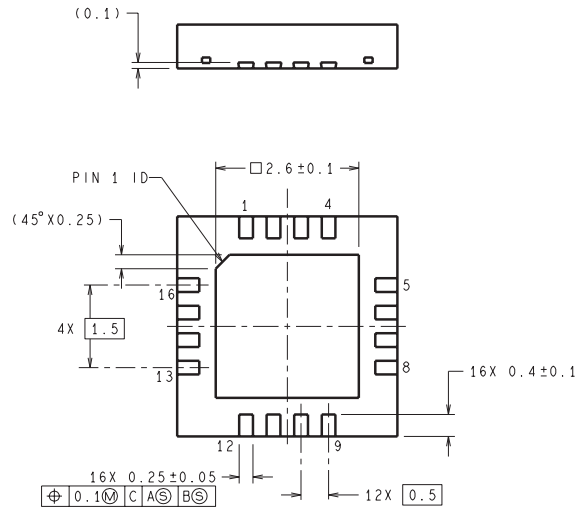
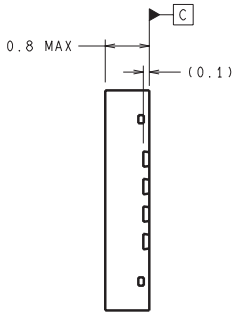
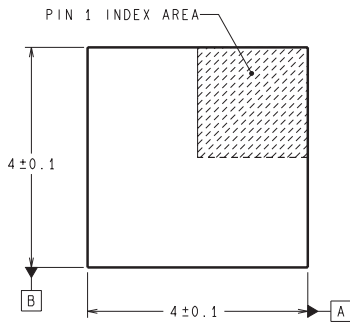

SQA16A (Rev A)

IMPORTANT NOTICE

Texas Instruments Incorporated and its subsidiaries (TI) reserve the right to make corrections, enhancements, improvements and other changes to its semiconductor products and services per JESD46, latest issue, and to discontinue any product or service per JESD48, latest issue. Buyers should obtain the latest relevant information before placing orders and should verify that such information is current and complete. All semiconductor products (also referred to herein as "components") are sold subject to TI's terms and conditions of sale supplied at the time of order acknowledgment.

TI warrants performance of its components to the specifications applicable at the time of sale, in accordance with the warranty in TI's terms and conditions of sale of semiconductor products. Testing and other quality control techniques are used to the extent TI deems necessary to support this warranty. Except where mandated by applicable law, testing of all parameters of each component is not necessarily performed.

TI assumes no liability for applications assistance or the design of Buyers' products. Buyers are responsible for their products and applications using TI components. To minimize the risks associated with Buyers' products and applications, Buyers should provide adequate design and operating safeguards.

TI does not warrant or represent that any license, either express or implied, is granted under any patent right, copyright, mask work right, or other intellectual property right relating to any combination, machine, or process in which TI components or services are used. Information published by TI regarding third-party products or services does not constitute a license to use such products or services or a warranty or endorsement thereof. Use of such information may require a license from a third party under the patents or other intellectual property of the third party, or a license from TI under the patents or other intellectual property of TI.

Reproduction of significant portions of TI information in TI data books or data sheets is permissible only if reproduction is without alteration and is accompanied by all associated warranties, conditions, limitations, and notices. TI is not responsible or liable for such altered documentation. Information of third parties may be subject to additional restrictions.

Resale of TI components or services with statements different from or beyond the parameters stated by TI for that component or service voids all express and any implied warranties for the associated TI component or service and is an unfair and deceptive business practice. TI is not responsible or liable for any such statements.

Buyer acknowledges and agrees that it is solely responsible for compliance with all legal, regulatory and safety-related requirements concerning its products, and any use of TI components in its applications, notwithstanding any applications-related information or support that may be provided by TI. Buyer represents and agrees that it has all the necessary expertise to create and implement safeguards which anticipate dangerous consequences of failures, monitor failures and their consequences, lessen the likelihood of failures that might cause harm and take appropriate remedial actions. Buyer will fully indemnify TI and its representatives against any damages arising out of the use of any TI components in safety-critical applications.

In some cases, TI components may be promoted specifically to facilitate safety-related applications. With such components, TI's goal is to help enable customers to design and create their own end-product solutions that meet applicable functional safety standards and requirements. Nonetheless, such components are subject to these terms.

No TI components are authorized for use in FDA Class III (or similar life-critical medical equipment) unless authorized officers of the parties have executed a special agreement specifically governing such use.

Only those TI components which TI has specifically designated as military grade or "enhanced plastic" are designed and intended for use in military/aerospace applications or environments. Buyer acknowledges and agrees that any military or aerospace use of TI components which have **not** been so designated is solely at the Buyer's risk, and that Buyer is solely responsible for compliance with all legal and regulatory requirements in connection with such use.

TI has specifically designated certain components as meeting ISO/TS16949 requirements, mainly for automotive use. In any case of use of non-designated products, TI will not be responsible for any failure to meet ISO/TS16949.

Products

Audio	www.ti.com/audio
Amplifiers	amplifier.ti.com
Data Converters	dataconverter.ti.com
DLP® Products	www.dlp.com
DSP	dsp.ti.com
Clocks and Timers	www.ti.com/clocks
Interface	interface.ti.com
Logic	logic.ti.com
Power Mgmt	power.ti.com
Microcontrollers	microcontroller.ti.com
RFID	www.ti-rfid.com
OMAP Applications Processors	www.ti.com/omap
Wireless Connectivity	www.ti.com/wirelessconnectivity

Applications

Automotive and Transportation	www.ti.com/automotive
Communications and Telecom	www.ti.com/communications
Computers and Peripherals	www.ti.com/computers
Consumer Electronics	www.ti.com/consumer-apps
Energy and Lighting	www.ti.com/energy
Industrial	www.ti.com/industrial
Medical	www.ti.com/medical
Security	www.ti.com/security
Space, Avionics and Defense	www.ti.com/space-avionics-defense
Video and Imaging	www.ti.com/video

TI E2E Community

e2e.ti.com

Mouser Electronics

Authorized Distributor

Click to View Pricing, Inventory, Delivery & Lifecycle Information:

[Texas Instruments:](#)

[LMH6518SQEVK](#)