

PRODUCT DATA DRAWING

REVISION HISTORY			
REV	DESCRIPTION	DATE	APPROVED
-	NRN 44455	12/19	BNK

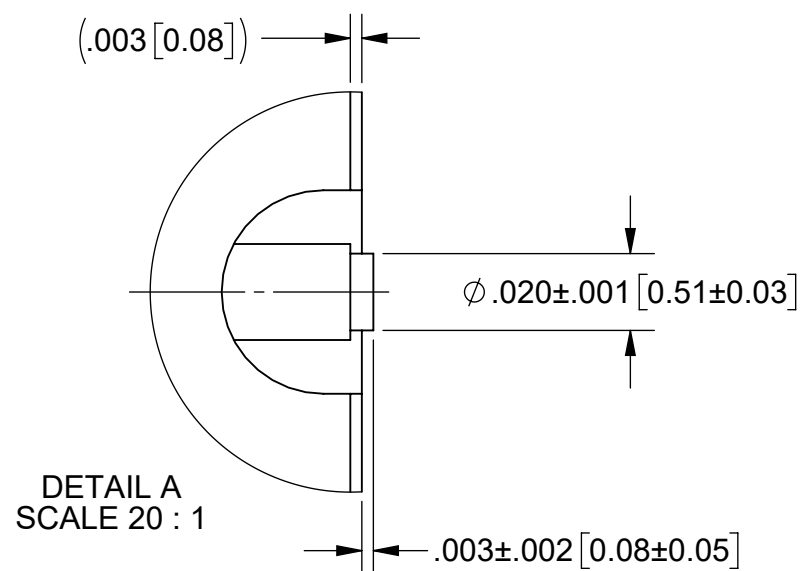
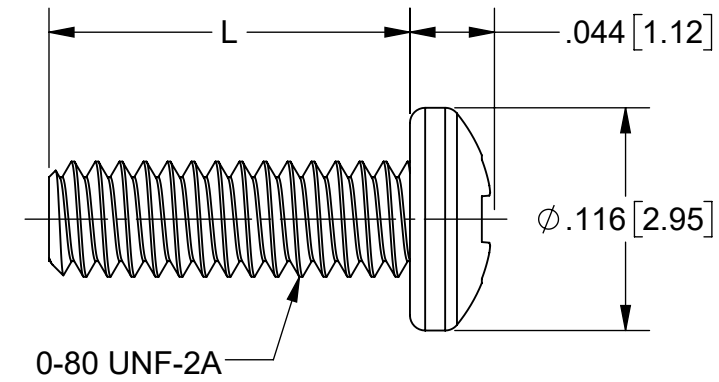
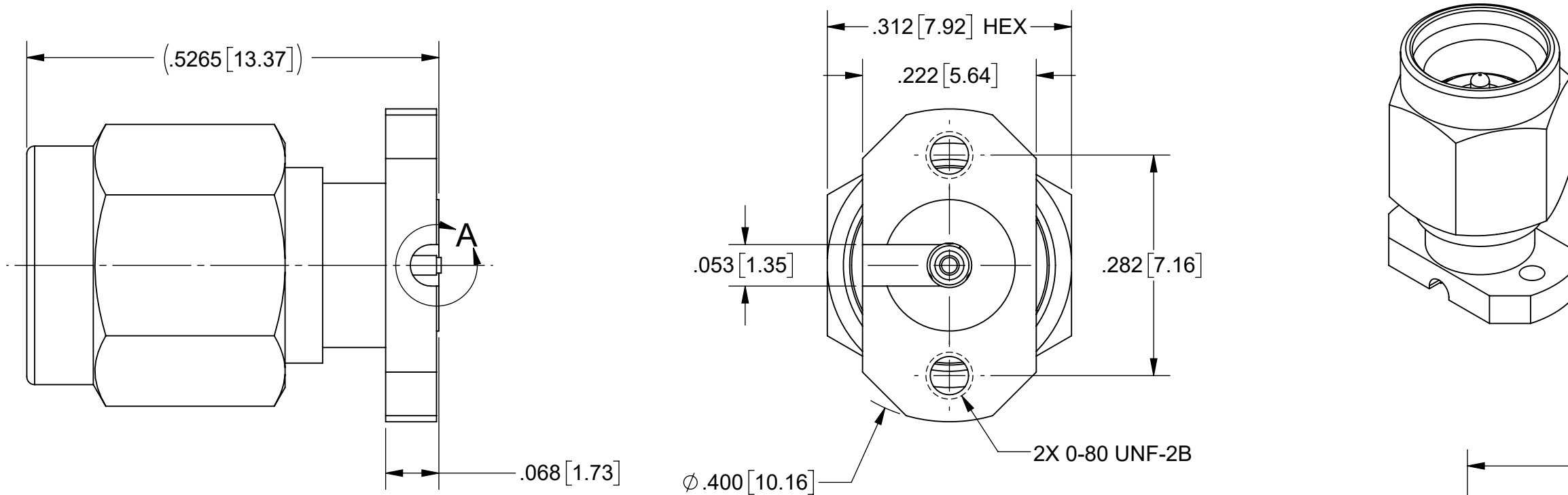

MATERIAL:
 BODY, INSERT & COUPLING NUT: STAINLESS STEEL PER AMS-5640, ALLOY UNS S30300, TYPE 1; OR ASTM A582 TYPE 303, COND. A
 LOCK RING & CONTACT: BERYLLIUM COPPER PER ASTM B196, ALLOY No. UNS C17300, TD04
 BEAD: ULTEM 1000 PER ASTM D5205
 GASKET: SILICONE RUBBER PER A-A-59588, CLASS 2B, GRADE 60/70

FINISH:
 BODY, INSERT & COUPLING NUT: PASSIVATED PER AMS-2700
 CONTACT: GOLD PER ASTM B488, TYPE II, CODE C, CLASS 1.27, OVER NICKEL PER AMS-QQ-N-290, CLASS 1, .00005" MIN.

PERFORMANCE:
 IMPEDANCE: 50 OHMS
 FREQ. RANGE: DC TO 40.0 GHz

SV P/N	DESCRIPTION	PCB THICKNESS	L
SF1511-60119	NO SCREWS	.005 TO .373	N/A
SF1511-60119-1S	INCL. TWO .188 SCREWS	.032 TO .123	.188
SF1511-60119-2S	INCL. TWO .250 SCREWS	.094 TO .185	.250
SF1511-60119-3S	INCL. TWO .438 SCREWS	.282 TO .373	.438

MATERIAL: SEE NOTES	DIMENSIONS ARE IN INCHES TOLERANCES: FRACTIONAL: ±1/64 ANGULAR: X° ±1'0" X°X' ±15'	UNLESS OTHERWISE SPECIFIED 1) ALL DIMENSIONS ARE IN INCHES (MILLIMETERS) 2) ALL DIMENSIONS ARE AFTER PLATING. 3) BREAK CORNERS & EDGES .005 R. MAX. 4) CHAM. 1ST & LAST THREADS. 5) SURFACE ROUGHNESS 63-MIL-STD-10. 6) DIA: 'S ON COMMON CENTERS TO BE CONCENTRIC WITHIN .005 T.I.R. 7) REMOVE ALL BURRS	 Amphenol www.svmicrowave.com TITLE: 2.92mm MALE 2 HOLE FLANGE COMPRESSION MOUNT
FINISH: SEE NOTES	DECIMAL: X ±.030 .XX ±.010 .XXX ±.005	INTERPRET DIMENSIONS AND TOLERANCES PER ASME Y14.5M - 1994	
SURFACE AREA: N/A	THIRD ANGLE PROJECTION	DRAWN: JDT 12/10/19 CHECKED: BNK 12/10/19 APPROVED: BNK 12/10/19	SIZE DWG. NO. SF1511-60119-XS SCALE: 6:1 SHEET 1 OF 1