

Features and Benefits

1. Industry-leading noise performance with greatly improved bandwidth through proprietary amplifier and filter design techniques
2. Small footprint package suitable for space-constrained applications
3. 1 mΩ primary conductor resistance for low power loss
4. High isolation voltage, suitable for line-powered applications
5. User-adjustable Overcurrent Fault level
6. Overcurrent Fault signal typically responds to an overcurrent condition in < 2 μs
7. Integrated shield virtually eliminates capacitive coupling from current conductor to die due to high dV/dt voltage transients
8. Filter pin capacitor improves resolution in low bandwidth applications
9. 3 to 5.5 V, single supply operation
10. Factory trimmed sensitivity and quiescent output voltage
11. Chopper stabilization results in extremely stable quiescent output voltage
12. Ratiometric output from supply voltage

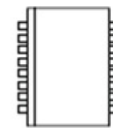

Approximate Scale 1:1



Package: 16-pin SOIC Hall Effect IC Package (suffix SI)

Typical Application Circuit

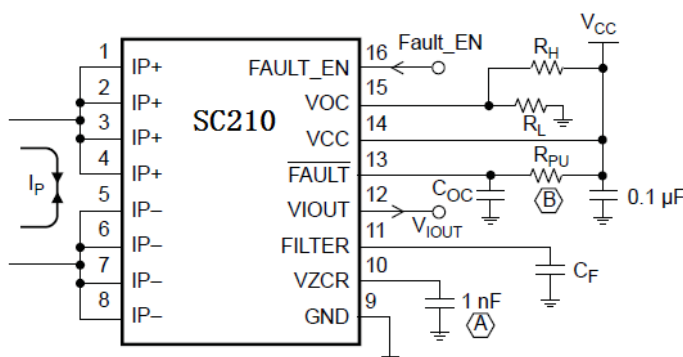

R_H, R_L	Sets resistor divider reference for V_{OC}
C_F	Noise and bandwidth limiting filter capacitor
C_{OC}	Fault delay setting capacitor, 22 nF maximum
(A)	Use of capacitor required
(B)	Use of resistor optional, 330 kΩ recommended. If used, resistor must be connected between FAULT pin and V_{CC} .

General Description

The SECTM SC210KSIT current sensor provides economical and precise means for current sensing applications in industrial, commercial, and communications systems. The device is offered in a small footprint surface mount package that allows easy implementation in customer applications.

The SC210KSIT consists of a precision linear Hall sensor integrated circuit with a copper conduction path located near the surface of the silicon die. Applied current flows through the copper conduction path, and the analog output voltage from the Hall sensor linearly tracks the magnetic field generated by the applied current. The accuracy of the SC210KSIT is maximized with this patented packaging configuration because the Hall element is situated in extremely close proximity to the current to be measured.

High level immunity to current conductor dV/dt and stray electric fields, offered by SEC proprietary integrated shield technology, results in low ripple on the output and low offset drift in high-side, high voltage applications.

The voltage on the Overcurrent Input (V_{OC} pin) allows customers to define an overcurrent fault threshold for the device. When the current flowing through the copper conduction path (between the I_{P+} and I_{P-} pins) exceeds this threshold, the open drain Overcurrent Fault pin will transition to a logic low state. Factory programming of the linear Hall sensor inside of the SC210KSIT results in exceptional accuracy in both analog and digital output signals.

The internal resistance of the copper path used for current sensing is typically $1\text{ m}\Omega$, for low power loss. Also, the current conduction path is electrically isolated from the low voltage sensor inputs and outputs. This allows the SC210KSIT family of sensors to be used in applications requiring electrical isolation, without the use of opto-isolators or other costly isolation techniques. The SC210KSIT is provided in a small, surface mount SOIC16 package. The lead frame is plated with 100% matte tin, which is compatible with standard lead (Pb) free printed circuit board assembly processes. Internally, the device is Pb-free, except for flip-chip high-temperature Pb-based solder balls, currently exempt from RoHS. The device is fully calibrated prior to shipment from the factory.

Applications

1. Motor control and protection
2. Load management and overcurrent detection
3. Power conversion and battery monitoring / UPS systems

General Package Inform

Part Number	$I_P(A)$	Sens (typ) at $V=5\text{ V}$ (mV/A)	Latched Fault	$T_A(^{\circ}C)$	Packing
SC210KSIT	± 15	85	Yes	-40 to 125	Tape and Reel, 1000 pieces per reel

Absolute Maximum Ratings

Characteristic	Symbol	Notes	Rating	Unit
Supply Voltage	V_{CC}		8	V
Filter Pin	V_{FILTER}		8	V
Analog Output Pin	V_{IOUT}		32	V
Overcurrent Input Pin	V_{OC}		8	V
Overcurrent \overline{FAULT} Pin	$V_{\overline{FAULT}}$		8	V
Fault Enable (FAULT_EN) Pin	$V_{FAULTEN}$		8	V
Voltage Reference Output Pin	V_{ZCR}		8	V
DC Reverse Voltage: V_{CC} , FILTER, V_{IOUT} , V_{OC} , FAUL, $\overline{FAULT_EN}$, and V_{ZCR} Pins	V_{Rdex}		-0.5	V
Excess to Supply Voltage: FILTER, V_{IOUT} , V_{OC} , \overline{FAULT} , FAULT_EN, and V_{ZCR} Pins	V_{EX}	Voltage by which pin voltage can exceed the V_{CC} pin voltage	0.3	V
Output Current Source	$I_{IOUT(Source)}$		3	mA
Output Current Sink	$I_{IOUT(Sink)}$		1	mA
Operating Ambient Temperature	T_A	Range K	-40 to 125	°C
Junction Temperature	$T_{J(max)}$		165	°C
Storage Temperature	T_{stg}		-65 to 170	°C

Isolation Characteristics

Characteristic	Symbol	Notes	Rating	Unit
Dielectric Strength Test Voltage*	V_{ISO}	Agency type-tested for 60 seconds per UL standard 1577	3000	VAC
Working Voltage for Basic Isolation	V_{WFSI}	For basic (single) isolation per UL standard 1577; for higher continuous voltage ratings, please contact SEC	277	VAC

Thermal Characteristics

Characteristic	Symbol	Test Conditions	Value	Unit
Package Thermal Resistance	$R_{\theta JA}$	When mounted on SEC demo board with 1332 mm ² (654 mm ² on component side and 678 mm ² on opposite side) of 2 oz. copper connected to the primary lead frame and	17	°C/W

Functional Block Diagram

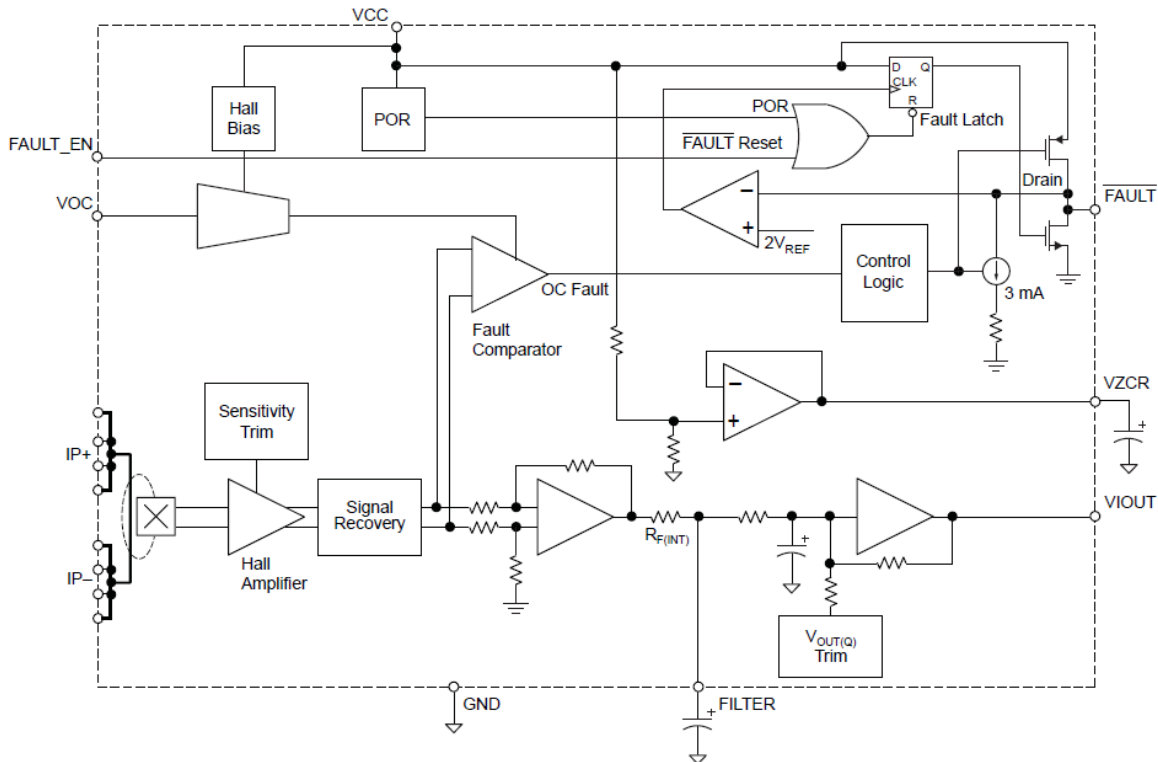

Terminal List Table, Latching Version

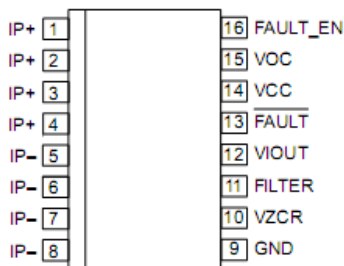

Number	Name	Description
1 through 4	I_{P+}	Sensed current copper conduction path pins. Terminals for current being sensed; fused internally, loop to I_{P-} pins; unidirectional or bidirectional current flow.
5 through 8	I_{P-}	Sensed current copper conduction path pins. Terminals for current being sensed; fused internally, loop to I_{P+} pins; unidirectional or bidirectional current flow.
9	GND	Device ground connection.
10	V_{ZCR}	Voltage Reference Output pin. Zero current (0 A) reference; output voltage on this pin scales with V_{CC} . (Not a highly accurate reference.)
11	FILTER	Filter pin. Terminal for an external capacitor connected from this pin to GND to set the device bandwidth.
12	V_{IOUT}	Analog Output pin. Output voltage on this pin is proportional to current flowing through the loop between the I_{P+} pins and I_{P-} pins.
13	\overline{FAULT}	Overcurrent Fault pin. When current flowing between I_{P+} pins and I_{P-} pins exceeds the overcurrent fault threshold, this pin transitions to a logic low state.
14	V_{CC}	Supply voltage.
15	V_{OC}	Overcurrent Input pin. Analog input voltage on this pin sets the overcurrent fault threshold.
16	$FAULT_EN$	Enables overcurrent faulting when high. Resets \overline{FAULT} when low.

COMMON OPERATING CHARACTERISTICS

 Valid at $T_A = -40^{\circ}\text{C}$ to 125°C , $V_{CC} = 5\text{ V}$, unless otherwise specified

Characteristic	Symbol	Test Conditions	Min.	Typ.	Max.	Units
ELECTRICAL CHARACTERISTICS						
Supply Voltage ¹	V_{CC}		3	–	5.5	V
Nominal Supply Voltage	V_{CCN}		–	5	–	V
Supply Current	I_{CC}	V_{IOUT} open, $\overline{\text{FAULT}}$ pin high	–	11	14.5	mA
Output Capacitance Load	C_{LOAD}	V_{IOUT} pin to GND	–	–	10	nF
Output Resistive Load	R_{LOAD}	V_{IOUT} pin to GND	10	–	–	k Ω
Magnetic Coupling from Device Conductor to Hall Element	MC_{HALL}	Current flowing from I_{P+} to I_{P-} pins	–	9.5	–	G/A
Internal Filter Resistance ²	$R_{F(INT)}$		–	1.7	–	k Ω
Primary Conductor Resistance	$R_{PRIMARY}$	$T_A = 25^{\circ}\text{C}$	–	1	–	m Ω
ANALOG OUTPUT SIGNAL CHARACTERISTICS						
Full Range Linearity ³	E_{LIN}	$I_P = \pm I_{POA}$	–0.75	± 0.25	0.75	%
Symmetry ⁴	E_{SYM}	$I_P = \pm I_{POA}$	99.1	100	100.9	%
Bidirectional Quiescent Output	$V_{OUT(QBI)}$	$I_P = 0\text{ A}$, $T_A = 25^{\circ}\text{C}$	–	$V_{CC}/2$	–	V
TIMING PERFORMANCE CHARACTERISTICS						
V_{IOUT} Signal Rise Time	t_r	$T_A = 25^{\circ}\text{C}$, Swing I_P from 0 A to I_{POA} , no capacitor on FILTER pin, 100 pF from V_{IOUT} to GND	–	3	–	μs
V_{IOUT} Signal Propagation Time	t_{PROP}	$T_A = 25^{\circ}\text{C}$, no capacitor on FILTER pin, 100 pF from V_{IOUT} to GND	–	1	–	μs
V_{IOUT} Signal Response Time	$t_{RESPONSE}$	$T_A = 25^{\circ}\text{C}$, Swing I_P from 0 A to I_{POA} , no capacitor on FILTER pin, 100 pF from V_{IOUT} to GND	–	4	–	μs
V_{IOUT} Large Signal Bandwidth	f_{3dB}	–3 dB, Apply I_P such that $V_{IOUT} = 1\text{ V}_{pk-pk}$, no capacitor on FILTER pin, 100 pF from V_{IOUT} to GND	–	120	–	kHz
Power-On Time	t_{PO}	Output reaches 90% of steady-state level, no capacitor on FILTER pin, $T_A = 25^{\circ}\text{C}$	–	35	–	μs
OVERCURRENT CHARACTERISTICS						
Setting Voltage for Overcurrent Switchpoint ⁵	V_{OC}		$V_{CC} \times 0.25$	–	$V_{CC} \times 0.4$	V
Signal Noise at Overcurrent Comparator Input	I_{NCOMP}		–	± 1	–	A
Overcurrent Fault Switchpoint Error ^{6,7}	E_{OC}	Switchpoint in V_{OC} safe operating area; assumes $I_{NCOMP} = 0\text{ A}$	–	± 5	–	%
Overcurrent $\overline{\text{FAULT}}$ Pin Output Voltage	$V_{\overline{\text{FAULT}}}$	1 mA sink current at $\overline{\text{FAULT}}$ pin	–	–	0.4	V

Fault Enable (FAULT_EN Pin) Input Low Voltage Threshold	V_{IL}		–	–	$0.1 \times V_{CC}$	V
Fault Enable (FAULT_EN Pin) Input High Voltage Threshold	V_{IH}		$0.8 \times V_{CC}$	–	–	V
Fault Enable (FAULT_EN Pin) Input Resistance	R_{FEI}		–	1	–	M Ω
OVERCURRENT CHARACTERISTICS						
Fault Enable (FAULT_EN Pin) Delay ⁸	t_{FED}	Set FAULT_EN to low, $V_{OC} = 0.25 \times V_{CC}$, $C_{OC} = 0$ F; then run a DC I_P exceeding the corresponding overcurrent threshold; then reset FAULT_EN from low to high and measure the delay from the rising edge of FAULT_EN to the falling edge of \overline{FAULT}	–	15	–	μ s
Fault Enable (FAULT_EN Pin) Delay(Non-Latching versions) ⁹	$t_{FED(NL)}$	Set FAULT_EN to low, $V_{OC} = 0.25 \times V_{CC}$, $C_{OC} = 0$ F; then run a DC I_P exceeding the corresponding overcurrent threshold; then reset FAULT_EN from low to high and measure the delay from the rising edge of FAULT_EN to the falling edge of \overline{FAULT}	–	150	–	ns
Overcurrent Fault Response Time	t_{OC}	FAULT_EN set to high for a minimum of 20 μ s before the overcurrent event; switchpoint set at $V_{OC} = 0.25 \times V_{CC}$; delay from I_P exceeding overcurrent fault threshold to $V_{\overline{FAULT}} < 0.4$ V,	–	1.9	–	μ s
Undercurrent Fault Response Time(Non-Latching versions)	t_{UC}	FAULT_EN set to high for a minimum of 20 μ s before the undercurrent event; switchpoint set at $V_{OC} = 0.25 \times V_{CC}$; delay from I_P falling below the overcurrent fault threshold to $V_{\overline{FAULT}} > 0.8 \times V_{CC}$, without external C_{OC} capacitor, $R_{PU} = 330$ k Ω	–	3	–	μ s
Overcurrent Fault Reset Delay	t_{OCR}	Time from $V_{FAULTEN} < V_{IL}$ to $V_{\overline{FAULT}} > 0.8 \times V_{CC}$, $R_{PU} = 330$ k Ω	–	500	–	ns
Overcurrent Fault Reset Hold Time	t_{OCH}	Time from $V_{FAULTEN} < V_{IL}$ to rising edge of $V_{\overline{FAULT}}$	–	250	–	ns
Overcurrent Input Pin Resistance	R_{OC}	$T_A = 25^\circ\text{C}$, V_{OC} pin to GND	2	–	–	M Ω
VOLTAGE REFERENCE CHARACTERISTICS						
Voltage Reference Output	V_{ZCR}	$T_A = 25^\circ\text{C}$ (Not a highly accurate reference)	$0.48 \times V_{CC}$	$0.5 \times V_{CC}$	$0.51 \times V_{CC}$	V
Voltage Reference Output Load Current	I_{ZCR}	Source current	3	–	–	mA
		Sink current	50	–	–	μ A
Voltage Reference Output Drift	ΔV_{ZCR}		–	± 10	–	mV

1. Devices are programmed for maximum accuracy at $V_{CC} = 5$ V. The device contains ratiometry circuits that accurately alter the 0 A Output Voltage and Sensitivity level of the device in proportion to the applied V_{CC} level. However, as a result of minor nonlinearities in the ratiometry circuit, additional output error will result when V_{CC} varies from the V_{CC} level at which the device was programmed. Customers that plan to operate the device at a V_{CC} level other than the V_{CC} level at which the device was programmed should contact their local SEC sales representative regarding expected device accuracy levels
2. Under these bias conditions.
3. RF(INT) forms an RC circuit via the FILTER pin.
4. This parameter can drift by as much as 0.8% over the lifetime of this product.
5. This parameter can drift by as much as 1% over the lifetime of this product.
6. See page 8 on how to set overcurrent fault switch point.
7. Switchpoint can be lower at the expense of switch point accuracy.
8. This error specification does not include the effect of noise. See the INCOMP specification in order to factor in the additional influence of noise on the fault switch point.
9. Fault Enable Delay is designed to avoid false tripping of an Overcurrent (OC) fault at power-up. A 15 μ s (typical) delay will always be needed, every time FAULT_EN is raised from low to high, before the device is ready for responding to any overcurrent event.
10. During power-up, this delay is 15 μ s in order to avoid false tripping of an Overcurrent (OC) fault.

PERFORMANCE CHARACTERISTICS

TA Range K, valid at $T_A = -40^{\circ}\text{C}$ to 125°C , $V_{CC} = 5\text{ V}$, unless otherwise specified

Characteristic	Symbol	Test Conditions	Min.	Typ.	Max.	Units
Optimized Accuracy Range ¹	I_{POA}		-12.5	-	12.5	A
Linear Sensing Range	I_R		-37.5	-	37.5	A
Noise ²	$V_{NOISE(rms)}$	$T_A = 25^{\circ}\text{C}$, Sens = 56 mV/A, $C_f = 0$, $C_{LOAD} = 4.7\text{ nF}$, R_{LOAD} open	-	1.50	-	mV
Sensitivity ³	Sens	$I_p = 12.5\text{ A}$, $T_A = 25^{\circ}\text{C}$	-	56	-	mV/A
		$I_p = 12.5\text{ A}$, $T_A = 25^{\circ}\text{C}$ to 125°C	-	56	-	mV/A
		$I_p = 12.5\text{ A}$, $T_A = -40^{\circ}\text{C}$ to 25°C	-	57	-	mV/A
Electrical Offset Voltage Variation Relative to V_{out} ⁴	V_{OE}	$I_p = 0\text{ A}$, $T_A = 25^{\circ}\text{C}$	-	± 4	-	mV
		$I_p = 0\text{ A}$, $T_A = 25^{\circ}\text{C}$ to 125°C	-	± 14	-	mV
		$I_p = 0\text{ A}$, $T_A = -40^{\circ}\text{C}$ to 25°C	-	± 23	-	mV
Total Output Error ⁵	E_{TOT}	Over full scale of I_{POA} , I_p applied for 5 ms, $T_A = 25^{\circ}\text{C}$ to 125°C	-	± 2.2	-	%
		Over full scale of I_{POA} , I_p applied for 5 ms, $T_A = -40^{\circ}\text{C}$ to 25°C	-	± 3.9	-	%

1. Although the device is accurate over the entire linear range, the device is programmed for maximum accuracy over the range defined by I_{POA} . The reason for this is that in many applications, such as motor control, the start-up current of the motor is approximately three times higher than the running current.
2. V_{pk-pk} noise (6 sigma noise) is equal to $6 \times V_{NOISE(rms)}$. Lower noise levels than this can be achieved by using C_f for applications requiring narrower bandwidth. See Characteristic Performance page for graphs of noise versus C_f and bandwidth versus C_f .
3. This parameter can drift by as much as 2.4% over the lifetime of this product.
4. This parameter can drift by as much as 13 mV over the lifetime of this product.
5. This parameter can drift by as much as 2.5% over the lifetime of this product.

Characteristic Performance

Bandwidth value, C_F Capacitor connected between FILTER pin and GND

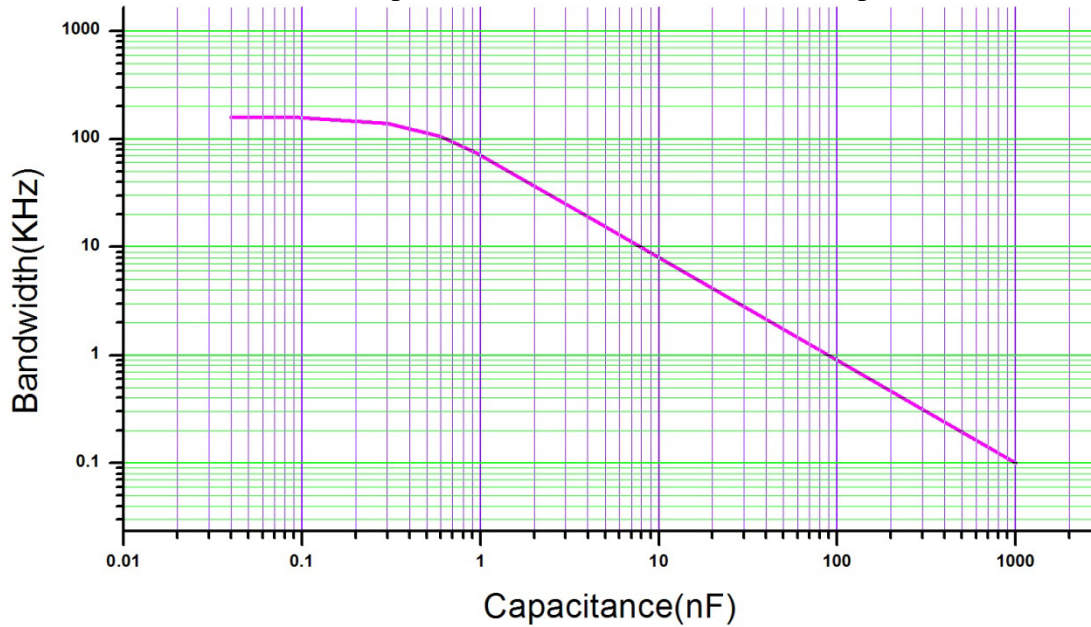

Noise versus External Capacitor Value

C_F Capacitor connected between FILTER pin and GND

Vcc = 5V

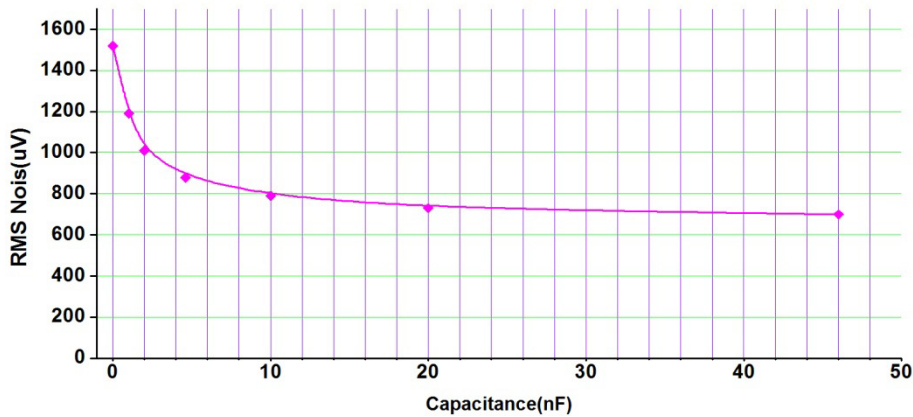

Vcc = 3.3V

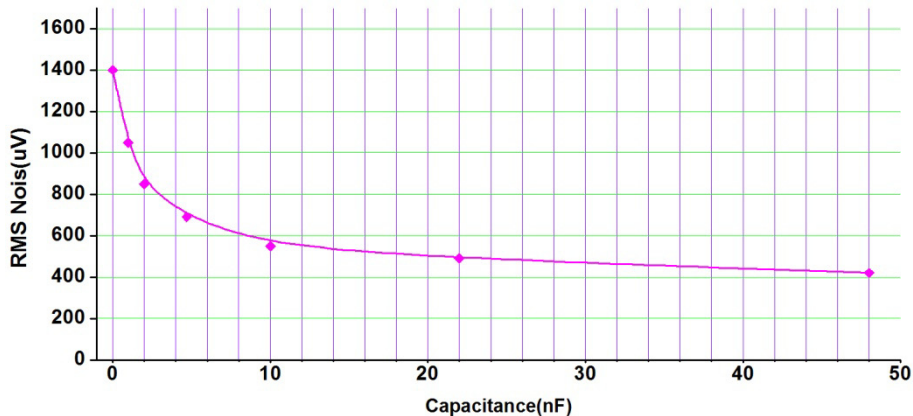

Characteristic Performance Data

Accuracy Data

Electrical Offset Voltage versus Ambient Temperature

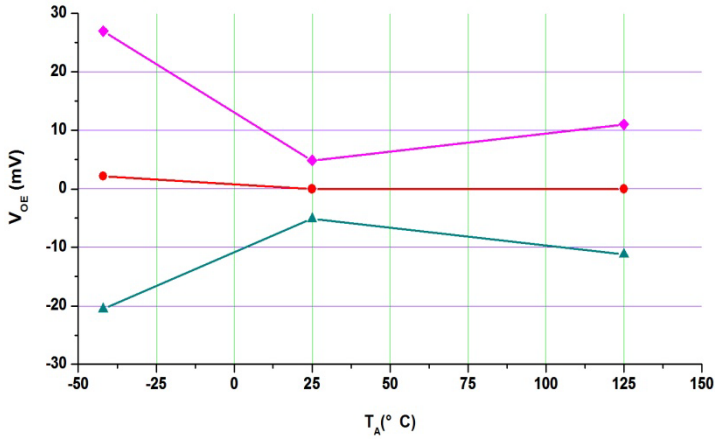

Sensitivity versus Ambient Temperature

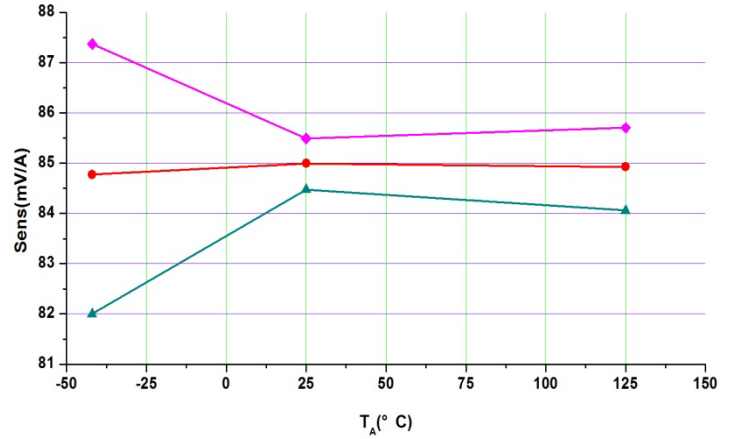

Nonlinearity versus Ambient Temperature

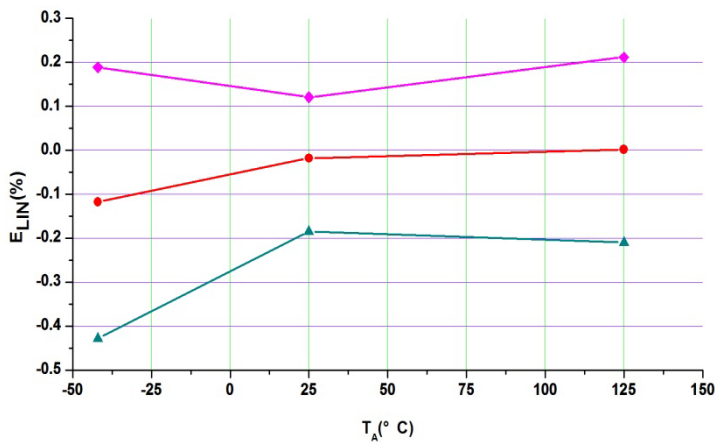

Symmetry versus Ambient Temperature

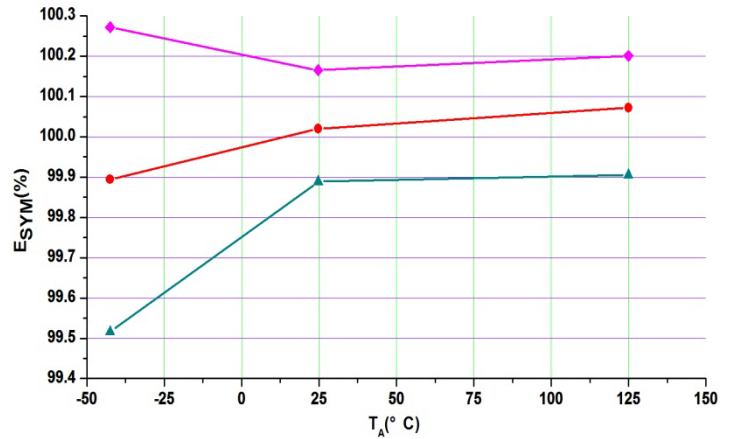

Total Output Error versus Ambient Temperature

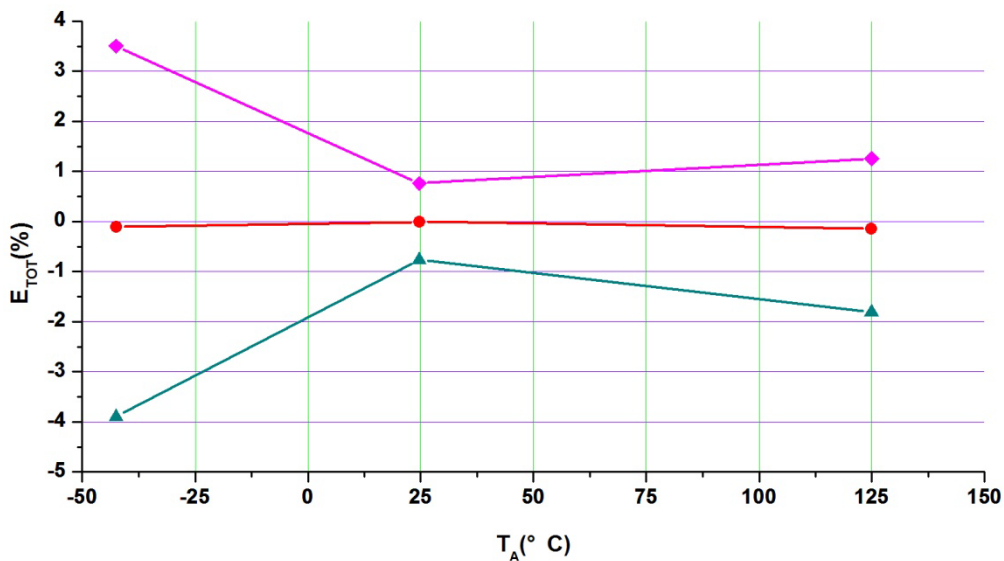

◆ Typical Maximum Limit ● Mean ▲ Typical Minimum Limit

Setting Overcurrent Fault Switchpoint

The V_{OC} needed for setting the overcurrent fault switchpoint can be calculated as follows:

$$V_{OC} = 1.17 \times \text{Sens} \times |I_{OC}|,$$

where V_{OC} is in mV, Sens in mV/A, and I_{OC} (overcurrent fault switchpoint) in A.

$|I_{OC}|$ is the overcurrent fault switchpoint for a bidirectional (AC) current, which means a bi-directional sensor will have two symmetrical overcurrent fault switchpoints, $+I_{OC}$ and $-I_{OC}$.

See the following graph for I_{OC} and V_{OC} ranges:

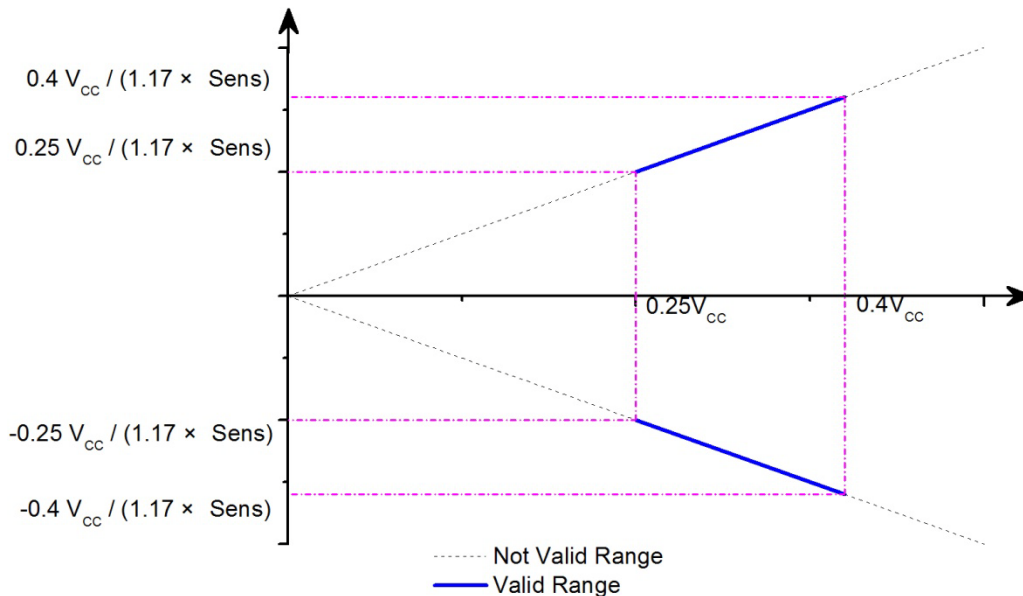

Example: For SC210KSIT, if required overcurrent fault switchpoint is 20 A, and $V_{CC} = 5$ V, then the required V_{OC} can be calculated as follows:

$$V_{OC} = 1.17 \times \text{Sens} \times I_{OC} = 1.17 \times 85 \times 15 = 1492 \text{ (mV)}$$

Overcurrent Fault Operation

The primary concern with high-speed fault detection is that noise may cause false tripping. Various applications have or need to be able to ignore certain faults that are due to switching noise or other parasitic phenomena, which are application dependant. The problem with simply trying to filter out this noise in the main signal path is that in high-speed applications, with asymmetric noise, the act of filtering introduces an error into the measurement.

To get around this issue, and allow the user to prevent the fault signal from being latched by noise, a circuit was designed to slew the $\overline{\text{FAULT}}$ pin voltage based on the value of the capacitor from that pin to ground. Once the voltage on the pin falls below 2 V, as established by an internal reference, the fault output is latched and pulled to ground quickly with an internal N-channel MOSFET.

Fault Walk-through

The following walk-through references various sections and attributes in the figure below. This figure shows different fault set/reset scenarios and how they relate to the voltages on the $\overline{\text{FAULT}}$ pin, FAULT_EN pin, and the internal Overcurrent (OC) Fault node, which is invisible to the customer.

1. Because the device is enabled (FAULT_EN is high for a minimum period of time, the Fault Enable Delay, t_{FED} , 15 μs typical) and there is an OC fault condition, the device $\overline{\text{FAULT}}$ pin

starts discharging.

2. When the $\overline{\text{FAULT}}$ pin voltage reaches approximately 2 V, the fault is latched, and an internal NMOS device pulls the $\overline{\text{FAULT}}$ pin voltage to approximately 0 V. The rate at which the $\overline{\text{FAULT}}$ pin slews downward (see [4] in the figure) is dependent on the external capacitor, C_{OC} , on the $\overline{\text{FAULT}}$ pin.
3. When the $\overline{\text{FAULT_EN}}$ pin is brought low, the $\overline{\text{FAULT}}$ pin starts resetting if no OC fault condition exists, and if $\overline{\text{FAULT_EN}}$ is low for a time period greater than t_{OCH} . The internal NMOS pull-down turns off and an internal PMOS pullup turns on (see [7] if the OC fault condition still exists).
4. The slope, and thus the delay to latch the fault is controlled by the capacitor, C_{OC} , placed on the $\overline{\text{FAULT}}$ pin to ground. During this portion of the fault (when the $\overline{\text{FAULT}}$ pin is between V_{CC} and 2 V), there is a 3 mA constant current sink, which discharges C_{OC} . The length of the fault delay, t is equal to:

$$t = \frac{C_{OC} \times (V_{CC} - 2V)}{3mA}$$

where V_{CC} is the device power supply voltage in volts, t is in seconds and C_{OC} is in Farads. This formula is valid for R_{PU} equal to or greater than 330 k Ω . For lower-value resistors, the current flowing through the R_{PU} resistor during a fault event, I_{PU} , will be larger. Therefore, the current discharging the capacitor would be 3 mA – I_{PU} and equation 1 may not be valid.

5. The $\overline{\text{FAULT}}$ pin did not reach the 2 V latch point before the OC fault condition cleared. Because of this, the fixed 3 mA current sink turns off, and the internal PMOS pull-up turns on to recharge C_{OC} through the $\overline{\text{FAULT}}$ pin.
6. This curve shows V_{CC} charging external capacitor C_{OC} through the internal PMOS pull-up. The slope is determined by C_{OC} .
7. When the $\overline{\text{FAULT_EN}}$ pin is brought low, if the fault condition still exists, the latched $\overline{\text{FAULT}}$ pin will be pulled low by the internal 3mA current source. When fault condition is removed then the Fault pin charges as shown in step 6.
8. At this point there is a fault condition, and the part is enabled before the $\overline{\text{FAULT}}$ pin can charge to V_{CC} . This shortens the user-set delay, so the fault is latched earlier. The new delay time can be calculated by equation 1, after substituting the voltage seen on the $\overline{\text{FAULT}}$ pin for V_{CC} .

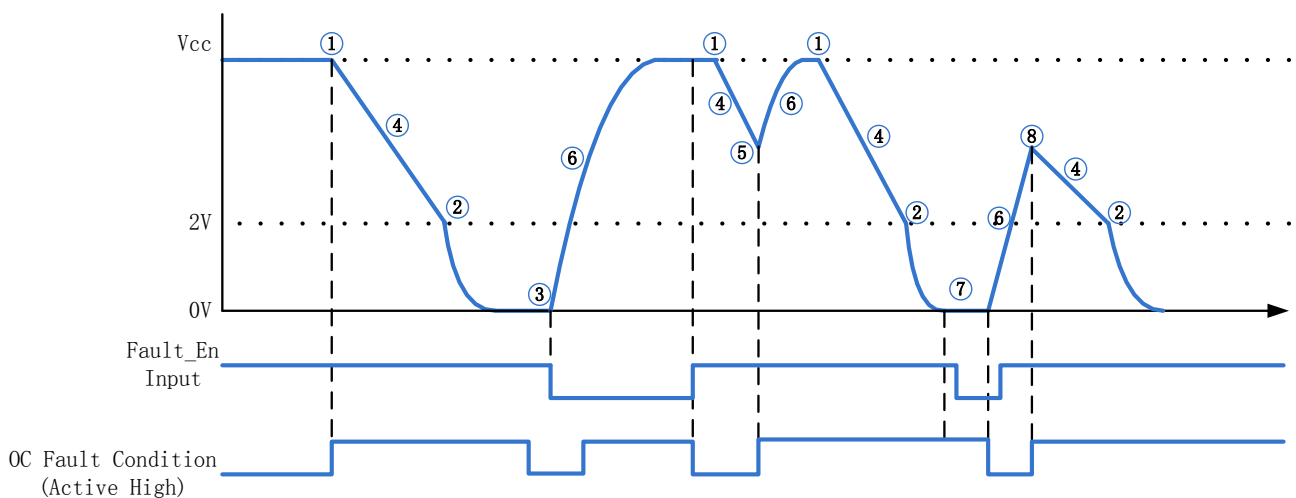

Package 16-pin SOICW

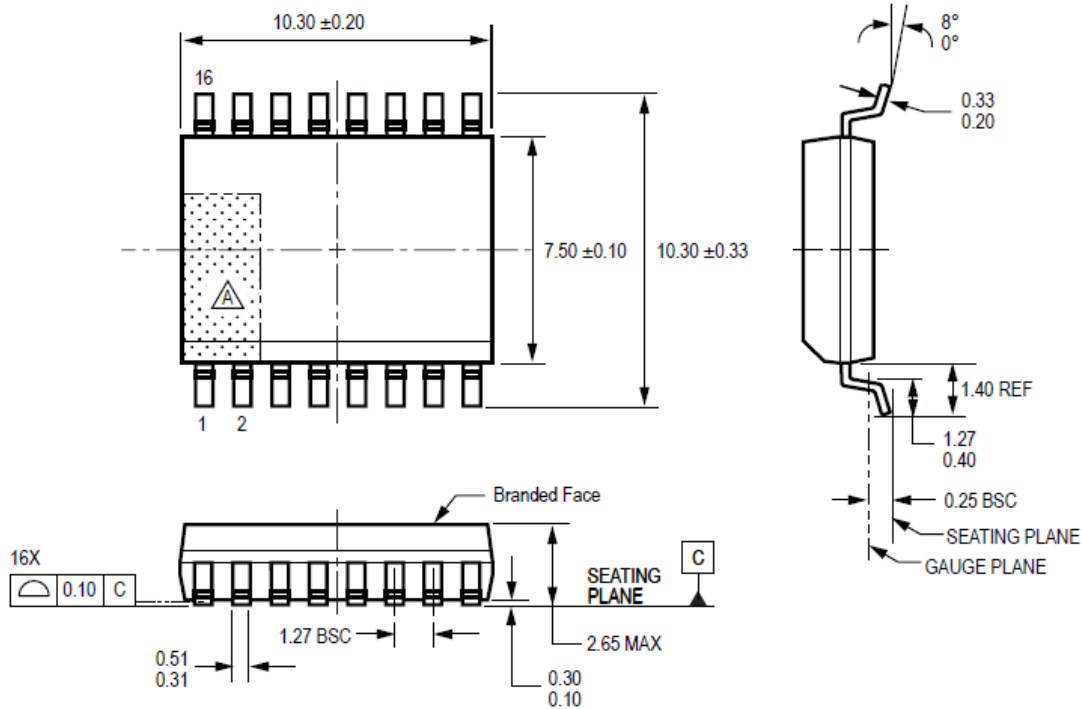

- Terminal #1 mark area
- Branding scale and appearance at supplier discretion
- Reference land pattern layout (reference IPC7351 SOIC127P600X175-8M); all pads a minimum of 0.20 mm from all adjacent pads; adjust as necessary to meet application process requirements and PCB layout tolerances

For Reference Only; not for tooling use (reference MS-013AA)

Dimensions in millimeters

Dimensions exclusive of mold flash, gate burrs, and dambar protrusions

Exact case and lead configuration at supplier discretion within limits shown

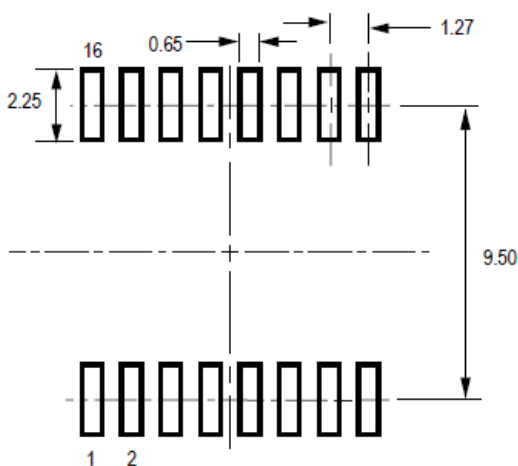

PCB Layout Reference View