



# 产品规格书

## PRODUCT SPECIFICATION

客户名称 CUSTOMER: \_\_\_\_\_

产品型号 MODEL: HNR-1704A

客户型号 USER'S MODEL: \_\_\_\_\_

日期 DATE: 2019-12-3

江苏华能电子有限公司			客户回签		
HUAWHA			CUSTOMER		
SERVE RATITY			CUSTOMER RATIGY		
拟制	审核	批准	检验	审核	批准
REPORT	CHECKED	APPROVED	TEST	CHECKED	APPROVED
王文娟	工稿用章	张长华			

江苏华能电子有限公司

JIANGSU HUAWHA ELECTRONICS CO.,LTD

地址：江苏省泰州市兴化市陈堡镇工业园区

ADD:Chenbao Industrial Park, Chenbao Town, Xinghua,Taizhou City, Jiangsu China.

电话 [TEL:0523-83710666](tel:0523-83710666)

传真 [FAX:0523-83724866](tel:0523-83724866)

网址: [www.huawha.com](http://www.huawha.com)

邮箱: [hndz\\_wwj@huawha.com](mailto:hndz_wwj@huawha.com)

项目/Item		规格/Spec	条件/Condition
1	额定电压 Rated voltage	12V	
2	工作电压 Operation voltage	1-30V	
3	声压 Sound Pressure Level=SPL	$\geq 90$ at 4.0KHz Square Wave	测试环境：标准状态，标准驱动电路， 额定电压 测试距离：0.1m Standard State,Standard Drive Circuit. Rated voltage,Distance at 0.1m
4	电流 current	Max5mA	
5	振荡频率 Oscillation frequency	4000 $\pm$ 500HZ	
6	电容量 Capacitance at 1000Hz (nF)	14 $\pm$ 30%	
7	工作温度范围 Operating Temperature	-20 $\sim$ +70 $^{\circ}$ C	
8	保存温度范围 Storage temperature	-30 $\sim$ +80 $^{\circ}$ C	
9	外部尺寸 Externals size (mm)	$\Phi 17*H4$	参阅附图 Refer to the attached drawing
10	重量 Mass	1g	
11	材质 Housing Material	PPO	

### 1.基本规格/General specification

### 2.电气和声学测试条件/Electrical And Acoustical Measuring Condition

#### 驱动电路/Recommended Driving Circuit

#### 设置 Recommended Setting

Resonant frequency, 1/2 duty cycle. Square wave.

Signal amplitude should be large enough to saturate the transistor.

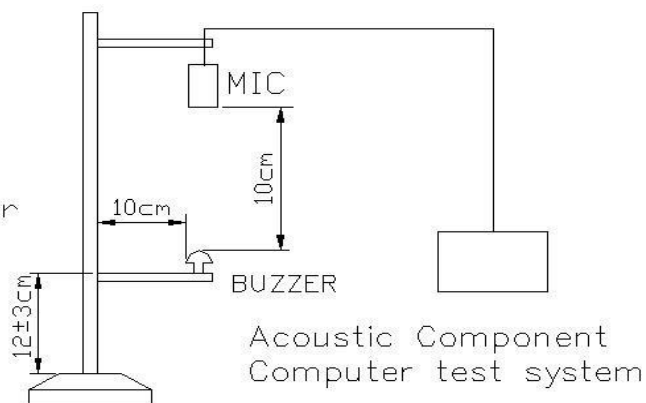
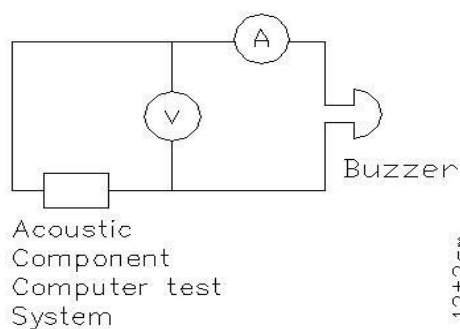

## 3.可靠性规范/Reliability specification

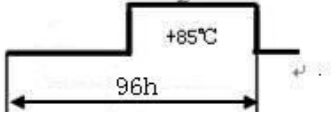
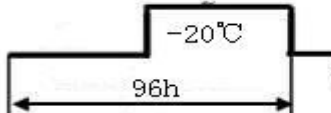
项目/Item		试验条件/Test condition	判断标准/Criteria
1	高温保存试验 High temperature preservation	+85°C环境下放置 24 小时 Exposure to +85°C for 24 hrs.	
2	低温保存试验 Low temperature preservation	-20°C环境下放置 24 小时 Exposure to -40°C for 24 hrs.	
3	高温试验 High temperature Shock		经过测试，符合规格，没有任何不合格的外观和性能 After the test the part shall meet specifications without any degradation.
4	低温试验 Low temperature Shock		
5	常温寿命试验 Ordinary Temp.Life	常温 (25°C±10°C) 电压 12V 连续测试 48 小时 Driving the sounder at 12V for 48hrs in the room temperature(25°C±10°C)	
6	高温寿命试验 High Temp.Life	高温(+85°C)电压 12V 连续测试 2 小时 Driving the sounder at 12V for 2hrs in the low temperature(+85°C)	
7	低温寿命试验 Low Temp.Life	低温(-20°C)电压 12V 连续测试 2 小时 Driving the sounder at 12v for 2hrs in the low temperature(-20°C)	
8	端子拉力试验 Lead strength	10N 的拉力在端子上拉 10±1 秒 Pull load on the direction of the terminal axis for 10 ±1 sec.	
9	跌落试验 Free drop	70cm 高自由掉落到厚 40mm 的木板上，每个方向一次 Free drop,70cm height, on wood board (t40mm) X,Y,Z 3Direction 1time each, total 3times.	

10	端子可焊性试验 Solderability	260±5℃焊接温度。时间：5±0.5sec。 Soldering into solderbath:Solder Temp.260±5℃ Soaking Time: 5±0.5sec	端子 95%必须覆盖着焊料 95% surface of lead pins must be covered with fresh solder and no soldering holes Should be found
----	--------------------------	---	--

4.尺寸图 Dimension

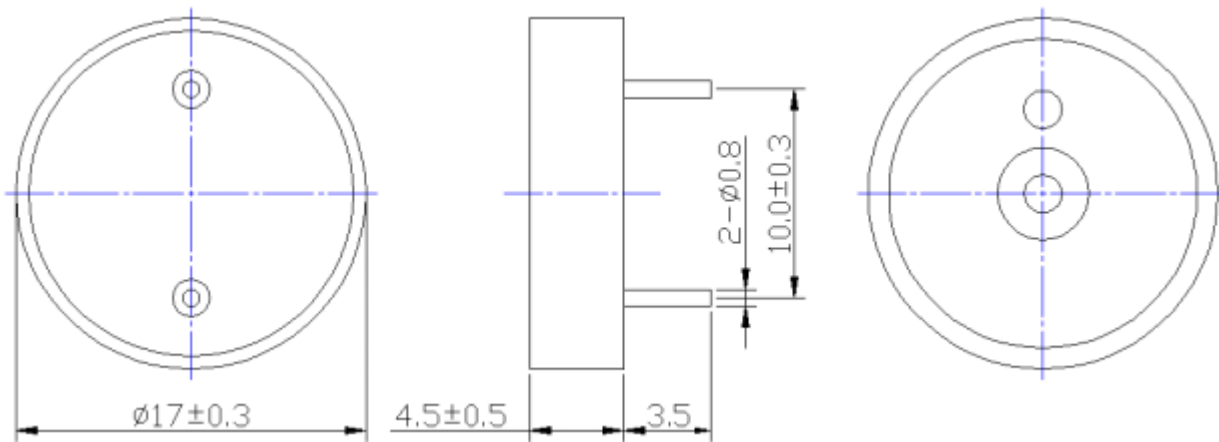

\*Unit: mm; Tolerance:  $\pm 0.3$ mm Except Specified

\*Housing Material: BlackPPO

5.频率响应/Frequency Response

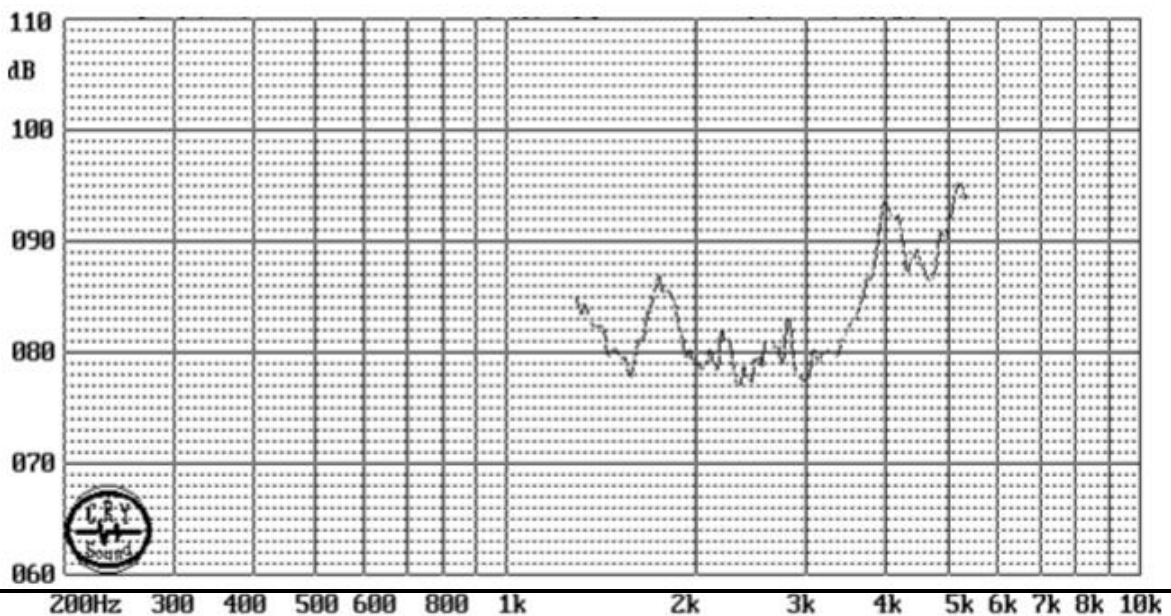

12Vo-p 50% duty Square wave,10cm