

# 710-319 Composite Split "Y" Junction Fitting for Series 72 and 74 Convuluted Tubing



## 710-319 XM 03\*04\*05

Basic Part No. ————  
 Finish (Table II) ————  
 End A Dash No. (Table I) ————

End C Dash No. (Table I)  
 End B Dash No. (Table I)

Note: When all ends are identical, insert only one dash no. When multiple dash numbers are ordered, transition size will be determined by the largest. Adapter may be supplied on smaller entries. Letter to follow entry will be supplied with adapters.

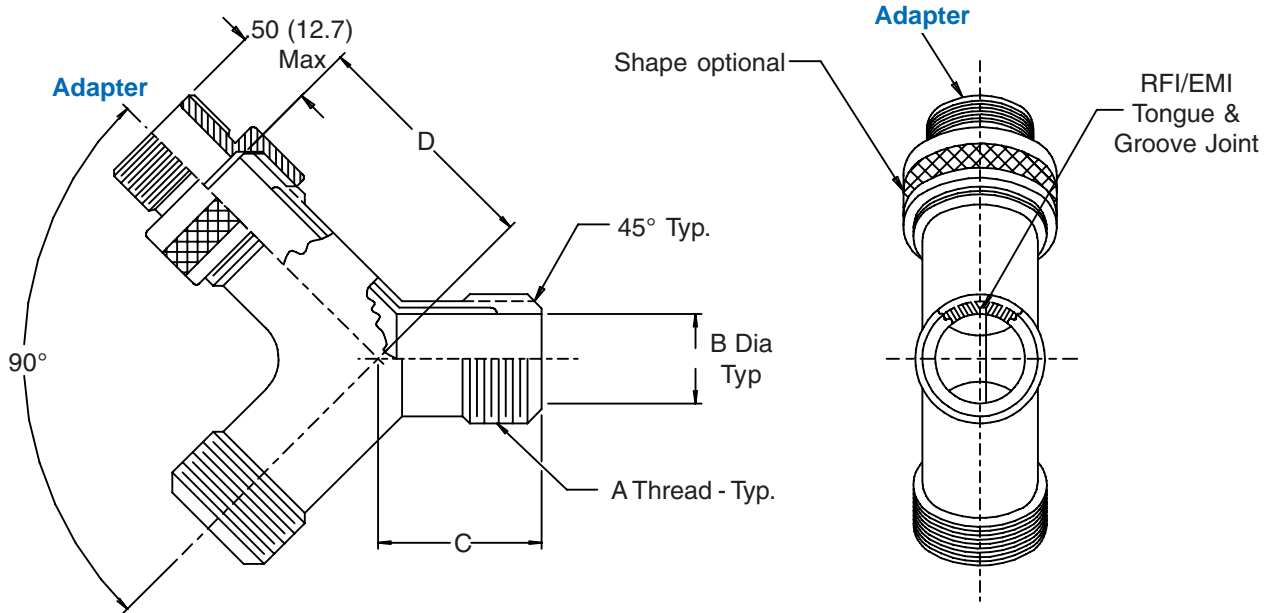

**Table I**

Dash No.	A Thread Unified	B Dia	C Max	D Max
01	.750 - 20	.500 (12.7)	1.312 (33.3)	1.312 (33.3)
02	1.000 - 20	.750 (19.1)	1.500 (38.1)	1.500 (38.1)
03	1.312 - 18	1.000 (25.4)	1.937 (49.2)	1.937 (49.2)
04	1.500 - 18	1.250 (31.8)	2.187 (55.5)	2.187 (55.5)
05	2.000 - 18	1.625 (41.3)	2.625 (66.7)	2.625 (66.7)

**Table II**

XM	Electroless Nickel
XW	Cadmium Olive Drab Over Electroless Nickel
XB	No Plating - Black Material
XO	No Plating - Base Material Non-conductive

1. Metric dimensions (mm) are in parentheses and are for reference only.
2. Consult factory for availability.