

FX-500 Low Jitter Frequency Translator



Features

- Complete Frequency Translator to 77.760 MHz
- 3.3 Volt or 5.0 Volt Supply
- Capable of locking to an 8 kHz pulse/BITS clock
- Tri-State Output allows board test
- J-lead Ceramic Package
- Advanced Customer ASIC Technology
- Absolute Pull Range Performance to ± 100 ppm
- CMOS Output
- Commercial or Industrial Temperature Range
- EIA Compatible Tape and Reel Packaging
- RoHS/Lead Free Compliant



Description

The FX-500 is a complete crystal-based frequency translator used in communications applications where low jitter is paramount.

Performance advantages include superior jitter performance, high output frequencies and small package size. Advanced custom ASIC technology results in a highly robust, reliable and predictable device.

The device is packaged in a 6 pin J-Lead ceramic package with a hermetic seam welded lid.

Applications

- Frequency Translation, Clock Smoothing
- Telecom – SONET/SDH/ATM
- Datacom – DSLAM, DSLAR, Access Nodes
- Cable Modem Head End
- Base Station – GSM, CDMA
- Military Communications

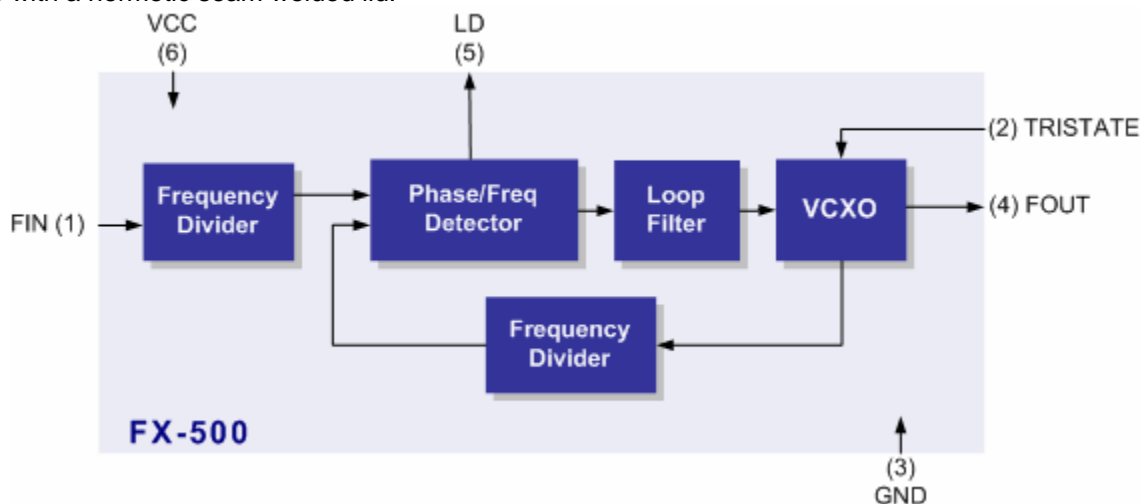

Figure 1. Functional Block Diagram

FX-500 Low Jitter Frequency Translator

Electrical Performance						
Parameter	Symbol	Minimum	Typical	Maximum	Units	Notes
Supply Voltage	V_{DD}	3.0	3.3	3.6	V	1,5
	V_{DD}	4.5	5.0	5.5	V	
Supply Current @ 19.44 MHz	I_{DD}		15	20	mA	
48.408 MHz	I_{DD}		25	30	mA	
77.760 MHz	I_{DD}		35	40	mA	
Input						
Input Low Level Voltage	V_{IL}			$0.3 \cdot V_{DD}$	V	
Input High Level Voltage	V_{IH}	$0.7 \cdot V_{DD}$			V	
Frequency	f_{IN}	1k		77.76 M	Hz	
Pulse Width		6			Ns	
Output						
Output High Level Voltage	V_{OH}	$0.9 \cdot V_{DD}$			V	
Output Low Level Voltage	V_{OL}			$0.1 \cdot V_{DD}$	V	
Transition Times						
Rise Time	t_R		1.8	3.0	ns	2
Fall Time	t_F		1.8	3.0	ns	
Duty Cycle	D				%	3,5
≤ 60 MHz		45		55		
≥ 60 MHz		40		60		
Nominal Output Frequency	f_O	0.100		77.76	MHz	4
Absolute Pull Range	APR	See Part Numbering			ppm	
Leakage Current of Input	I_C	-1		1	μA	
Loop Bandwidth (-3 dB), 8 kHz Input	BW		10		Hz	
Jitter (Application: 8 kHz to 77.76 MHz)	Φ_J					
rms			4.7		ps	
peak/peak			44		ps	
peak/peak			0.003		UI	
Operating Temperature	T_{OP}	-40		+85	$^{\circ}C$	5
Package Size		9.0 x 14.0 x 4.5			Mm	

1. A 0.1 μF low frequency tantalum bypass capacitor in parallel with a 0.01 μF high frequency ceramic capacitor is recommended.
2. Figure 3 defines the waveform parameters. Figure 2 illustrates the standard test conditions under which these parameters are specified and tested.
3. Duty cycle is defined as (on time=period), with $V_S = V_{DD}/2$, per figure 3. Duty cycle is measured with a 15pf load per figure 2.
4. Other frequencies may be available, please contact factory.
5. See Standard Frequencies and Ordering Information (Pg 6).

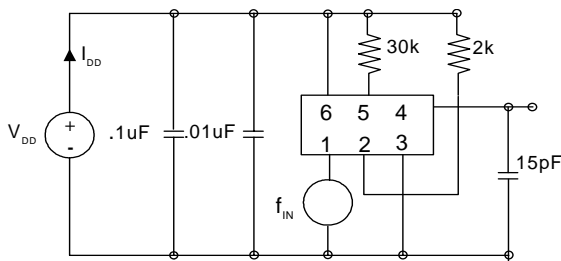

Figure 2. Test Circuit

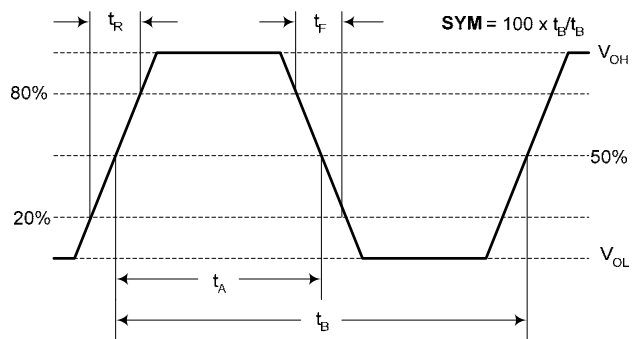

Figure 3. Output Waveform

Outline Diagram

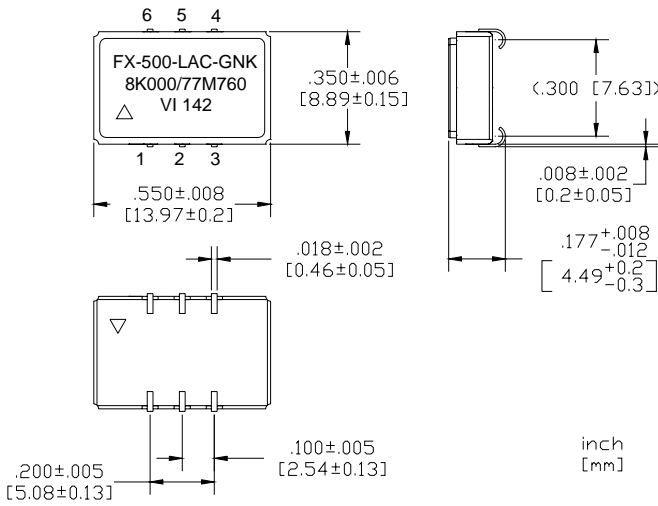

Figure 4.

Suggested Pad Layout

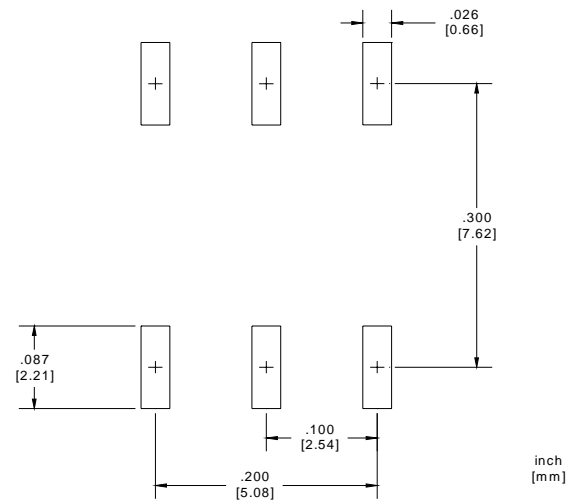

Figure 5.

Pin Out

Pin #	Symbol	Function
1	f_{IN}	Input Frequency
2	Tri-state ¹	Logic Low = Output Disable Logic High = Output Enabled
3	GND	Case and Electrical Ground
4	f_O	Output Frequency
5	LD ²	Lock Detect
6	V_{DD}	Power Supply Voltage (3.3 V ± 0.3 or 5.0 V ± 0.5)

1. Tri-state is driven to logic high or logic low; there is no internal pull up or pull down resistor.
2. LD is an open collector output requiring a 30k ohm pullup resistor to V_{DD} . LD output is logic high under locked condition, logic low for no input at f_{IN} , and for "out-of-lock" condition LD transitions between logic low and logic high at the phase detector frequency.

Tape and Reel (EIA-481-2-A)

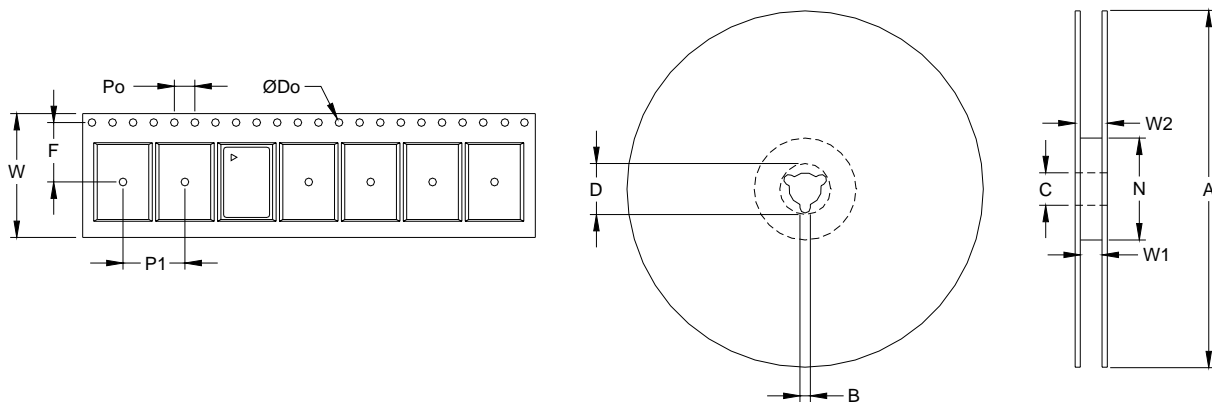

Tape Dimensions (mm)

Reel Dimensions (mm)

Dimension	W	F	Do	Po	P1	A	B	C	D	N	W1	W2	# Per Reel
Tolerance	Typ	Typ	Typ	Typ	Typ	Typ	Min	Typ	Min	Min	Typ	Max	
FX-500	24	11.5	1.5	4	12	330	1.78	13	20.2	100	24.4	30.4	200

FX-500 Low Jitter Frequency Translator

Absolute Maximum Ratings

Parameter	Symbol	Ratings	Unit
Power Supply	V _{CC}	0 to 7	Vdc
Storage Temperature	TS	-55 to 125	°C
Soldering Temp/Time	T _{LS}	260/40	°C/sec

Stresses in excess of the absolute maximum ratings can permanently damage the device. Functional operation is not implied at these or any other conditions in excess of conditions represented in the operational sections of this data sheet. Exposure to absolute maximum ratings for extended periods may adversely affect device reliability.

Reliability

The FX-500 family is capable of meeting the following qualification tests:

Environmental Compliance

Parameter	Conditions
Mechanical Shock	MIL-STD-883, Method 2002
Mechanical Vibration	MIL-STD-883, Method 2007
Solderability	MIL-STD-883, Method 2003
Gross and Fine Leak	MIL-STD-883, Method 1014
Resistance to Solvents	MIL-STD-883, Method 2016

Handling Precautions

Although ESD protection circuitry has been designed into the FX-500 proper precautions should be taken when handling and mounting. VI employs a human body model and a charged-device model (CDM) for ESD susceptibility testing and design protection evaluation.

ESD Ratings

Model	Minimum	Conditions
Human Body Model	1000 V	MIL-STD 883, Method 3015
Charged Device Model	1000 V	JEDEC, JESD22-C101

Reflow Profile (IPC/JEDEC J-STD-020C)

Parameter	Symbol	Value
PreHeat Time	t_s	60 sec Min, 180 sec Max
Ramp Up	R_{UP}	3 °C/sec Max
Time Above 217 °C	t_L	60 sec Min, 150 sec Max
Time To Peak Temperature	t_{AMB-P}	480 sec Max
Time At 260 °C	t_P	20 sec Min, 40 sec Max
Ramp Down	R_{DN}	6 °C/sec Max

The FX-500 has been qualified to meet the JEDEC standard for Pb-Free assembly. The temperatures and time intervals listed are based on the Pb-Free small body requirements. The temperatures refer to the topside of the package, measured on the package body surface. The FX-500 device is hermetically sealed so an aqueous wash is not an issue.

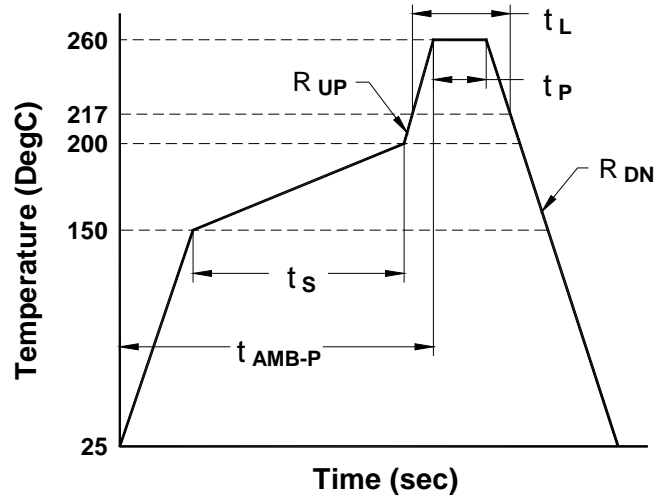

FX-500 Low Jitter Frequency Translator

Standard Frequencies (MHz)*											
0.00100	A1	0.40000	AF	10.00000	C4	20.48000	E4	38.88000	H5	62.20800	J8
0.00400	A2	0.48000	AK	10.48720	DN	24.57600	E6	40.00000	JF	65.53600	J6
0.00800	A3	0.51200	AJ	12.28800	D8	24.70400	E7	44.73600	J3	73.72800	K8
0.01000	A6	0.65545	AE	12.35200	D1	25.00000	F7	44.92800	JE	77.76000	K2
0.01573	AD	1.02400	B2	16.00000	D9	25.60000	F6	49.15200	J7		
0.01575	AC	1.22880	BK	16.38400	D5	27.00000	F4	49.40800	J2		
0.04800	AB	1.54400	B3	19.44000	D6	32.00000	H2	50.00000	JD		
0.06400	A5	2.04800	B4	19.69897	DK	32.76800	H3	51.84000	J4		
0.10000	AH	6.31200	C7	19.71900	DH	34.36800	H6	60.00000	JR		
0.25600	AM	7.68000	C9	20.00000	E2	37.05600	H4	61.44000	J5		

Note 1: Other frequencies are available upon request, please contact VI for details.

SS is code for non-standard frequencies, list the frequency after the part number.

Note 2: Not all combinations are possible.

Note 3: Output frequency must be equal to or greater than the input frequency. The ratio of f_o/f_{in} must be an integer. Also, the output frequency must be equal to greater than 100 kHz.

Ordering Information

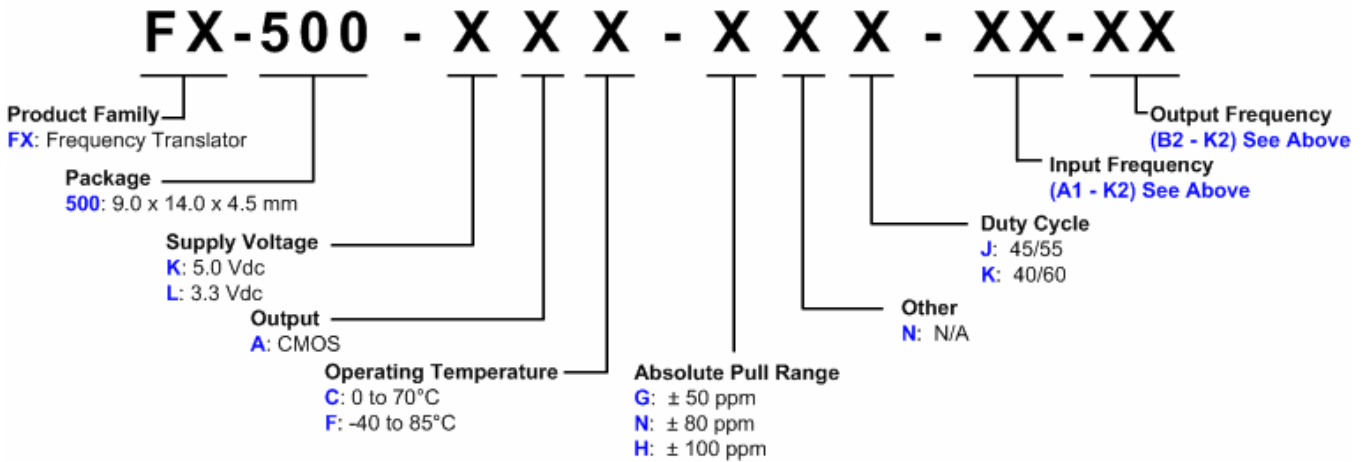

EXAMPLE: FX-500-LAC-GNK-A3-K2

FX-500, 3.3V, CMOS output, 0 to 70°C operating temperature, ±50 ppm APR, 40/60% duty cycle with an 8 kHz input and 77.760 MHz output.

For Additional Information, Please Contact:



USA: Vectron International • 267 Lowell Rd. Hudson, NH 03051 •
Tel: 1-88-VECTRON-1 • Fax: 1-888-FAX-VECTRON

EUROPE: Landstrasse, D-74924, Neckarbischofsheim, Germany •
Tel: 49 (0) 7268 8010 • Fax: 49 (0) 7268 801281

ASIA: 1F-2F, No 8 Workshop, No. 308 Fenju Road, WaiGaoQiao Free Trade Zone, Pudong, Shanghai, China 200131
Tel: 86 21 5048 0777 • Fax: 86 21 5048 1881

Vectron International reserves the right to make changes to the product(s) and or information contained herein without notice. No liability is assumed as a result of their use or application. No rights under any patent accompany the sale of any such product(s) or information.