

DEVR40

Electric Vehicle Contactor

DURAKOOL

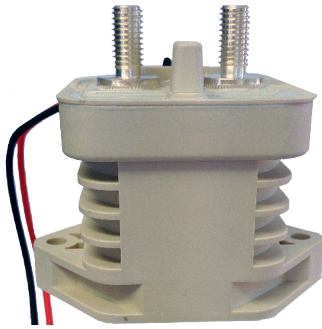

- High current and high voltage capability
- Compact structure - Low noise
- Magnetic arc blowout
- Rated 400A
- Reliable contacts sealed in inert gas
- Coil Economizer & Back EMF protection
- RoHS Compliant

Power Contacts

Contact number & arrangement	SPST-NO (1NO)
Contact material	AgSnO ₂
Max. switching voltage	900VDC (see Figs. 1 & 2)
Rated continuous current	400A * (150mm ² busbar, 65°C) , 500A (200mm ² busbar, 65°C)
Max. break current	2000A (at 320VDC, 1 operation)
Voltage drop	≤60mV@200A)

Optional Auxillary Contacts

Contact number & arrangement	SPST-NO (1NO)
Contact material	AgSnO ₂
Max. contact current	2A @ 30VDC / 3A @ 125VAC)
Min. contact current	100mA @ 8VDC
Contact resistance	0.417Ω @ 30VDC / 0.150V @ 125VAC

Coil

Rated voltage	9 ~ 95VDC with Coil Economizer
Operating range of supply voltage	See coil data 'Table 1'

Insulation

Insulation resistance (Initial / End of Life)	100MΩ / 50MΩ at 500VDC (max. current 650VDC)
Dielectric strength	coil - contact 2,200Vrms / 4000VDC
	contact - contact 5,000Vrms (leakage current <10mA, 1 minute @ sea level)

General Data

Operating time @ 25°C (Operate/Release)	mS	≤ 25ms. (includes bounce time - 7ms max) / ≤12ms.
Electrical life (resistive load, L/R ≤ 1ms)		See Fig. 1
Electric vehicle charging circuit		
Electrical life @90% capacitive pre-charge (make only)		50,000 ops (tested at 320VDC 200uH. Load = 2500A)
Electrical life @80% capacitive pre-charge (make only)		50 ops (tested at 320VDC 200uH. Load = 2500A)
Mechanical life	ops	1 x 10 ⁶
Dimensions	L x W x H	80.44 x 65.6 x 72.3mm (see drawings for detail)
Weight		430g
Ambient Temperature	operating / storage	-40 to +85°C
Shock resistance		15G, 11ms ½ sine, peak
Vibration resistance		15G, sine, peak (80~2,000 Hz)

* Consult factory for higher current capabilities

DEV40

Electric Vehicle Contactor



Coil Data - DEV40

Table 1

Coil Voltage Code	Nominal Voltage (VDC)	Must Operate Voltage Max. (VDC)	Maximum Allowable Voltage (VDC)	Must Release Voltage Min. (VDC)	Hold Voltage Min. (VDC)	Inrush Current Max. (A)	Hold Current. Average
0936	9 - 36	9.0	36	6.0	7.5	3.8	130mA @ 12VDC 70mA @ 24VDC
3295	32 - 95	32	95	18.0	22	1.3	30mA @ 48VDC
4895	48 - 95	48	95	27.0	34	0.7	20mA @ 72VDC

Ordering Codes

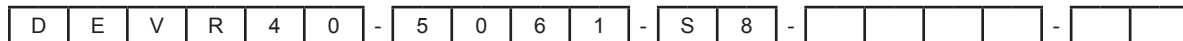

Contact Material

50 - AgSnO₂

Contact Arrangement

- 61 - SPST-NO. Polarity Conscious
- 71 - SPST-NO with aux.contacts. Polarity conscious
- 81 - SPST-NO. No Polarity
- 91 - SPST-NO with aux. contacts. No Polarity

Cover Protection and Mounting

S - Hermetic sealed, Flange mount

Connection Mode

8 - M8 x 10mm male

Coil Code

See Coil Data (Table 1)

Coil Wire Length

- R - 380mm (14.96")
- T - 150mm (5.9")

Other lengths available to order

Coil Wire Termination

1 - None

Other terminations to special order

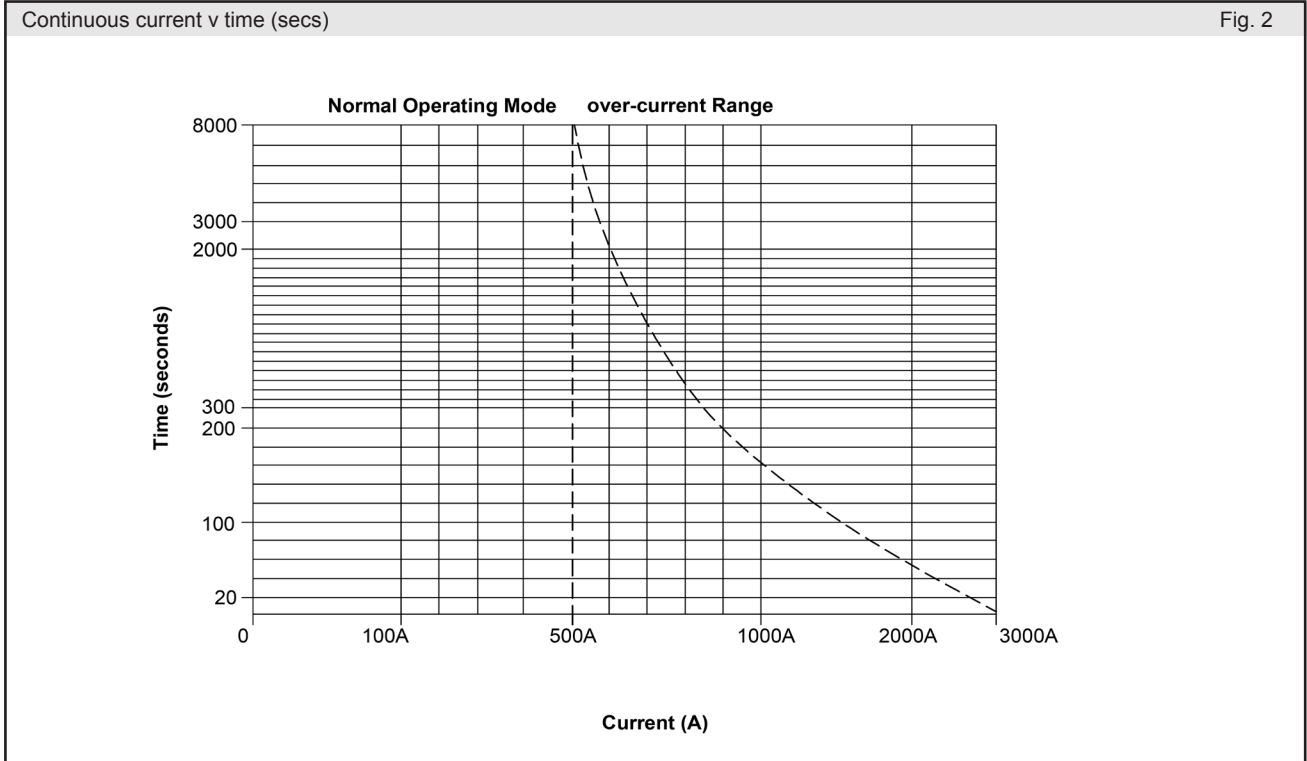
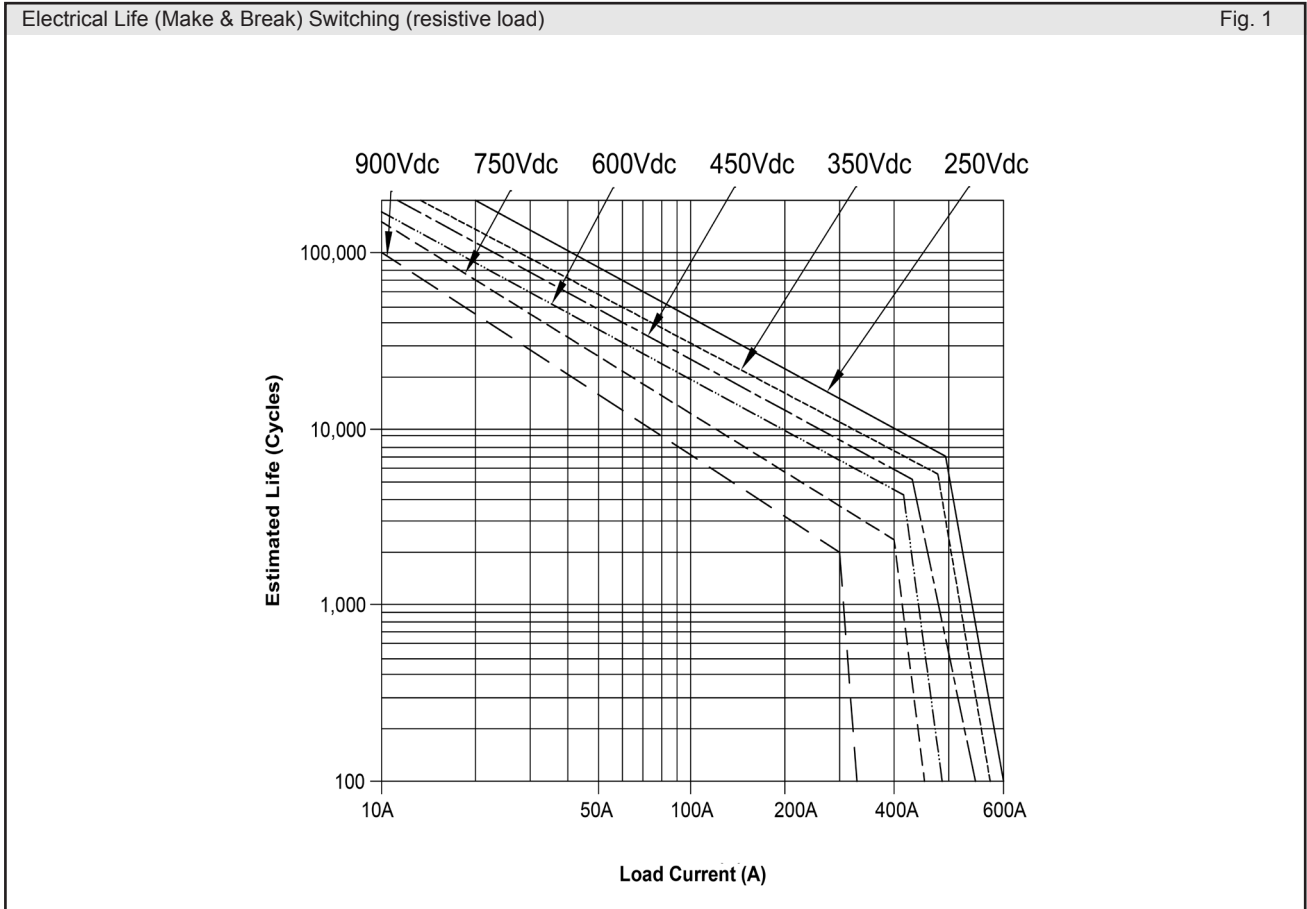

DEV40

Electric Vehicle Contactor

DURAKOOL

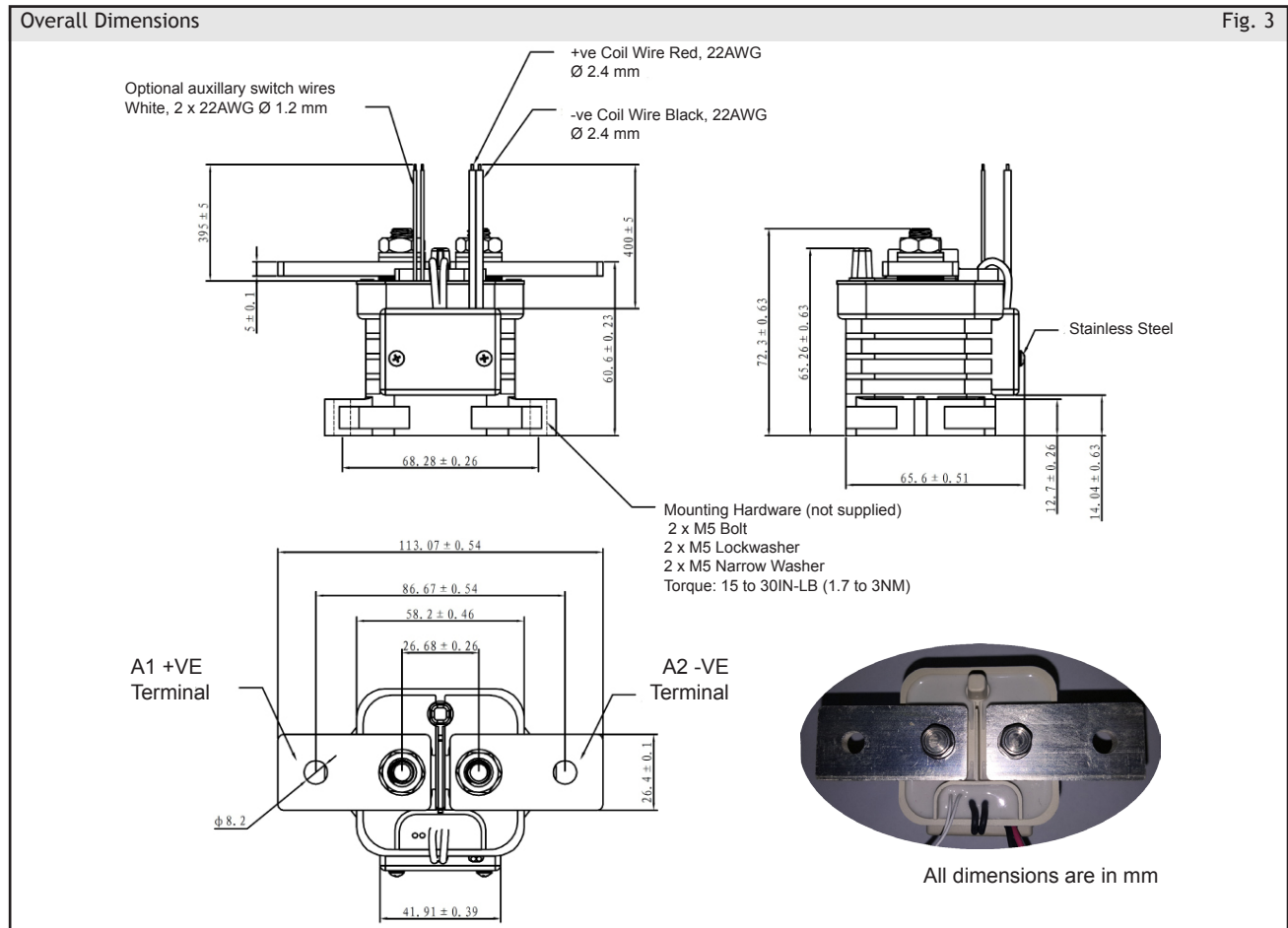

Notes:

- 1) Spring Washers for the power terminals are an essential requirement for installation.
- 2) Torque setting for the M8 Power Terminals is 8.8 to 11Nm. Exceeding the maximum torque may lead to product failure.
- 3) Loose terminals will generate excessive heat leading to premature failure and risk of fire.
- 4) The maximum torque setting for the M5 mounting bolts (not supplied) is 1.7 to 3.3Nm. to avoid damage to the contactor body.
- 6) For polarity conscious versions, please ensure the correct polarity of the wiring to the power terminals. Contact life is greatly reduced if the power terminals are incorrectly connected.
- 7) The contactor coil terminals are polarized. Please ensure they are connected the correctly. This contactor has an Energy Optimizer control PCB with an integral surge absorption circuit. external diodes are unnecessary and may degrade performance. The Energy Optimizer actuates approximately 0.1s after power is applied to the coil terminals, do not repeat on/off or switch off during this time as damage to the contactor may occur. the available coil drive circuit power must exceed the contactor coil power requirements.
- 8) Ensure adequate circuit protection in case of contact malfunction.
- 9) The contact chamber contains an inert gas. For maximum life, do not exceed the ambient temperature range of -40 to +85°C.
- 10) Contact ratings are based upon a resistive load. For inductive loads an inrush protection device is recommended.
- 11) Avoid installing in a strong magnetic field (motor, transformer, external magnet etc.) and protect from heat radiation from nearby objects. The contactor coil performance changes with temperature (like all relays and contactors), this might occur from self-heating or from an external source, and it will affect the pull-in (operate) performance.