

GMX24-MFT N4 Technical Data Sheet

NEMA 4X, Modulating Control, Non-Spring Return, Direct Coupled,
24 V, Multi-Function Technology®



Technical Data

Power Supply	24 VAC, ±20%, 50/60 Hz, 24 VDC, ±10%
Power consumption in operation	4 W
Power consumption in rest position	2 W
Transformer sizing	7 VA (class 2 power source)
Shaft Diameter	1/2...1.05" round, centers on 1/2" and 3/4" with insert, 1.05" without insert
Electrical Connection	Screw terminal (for 26 to 14 GA wire), 1/2" conduit connector
Overload Protection	electronic throughout 0...95° rotation
Operating Range	2...10 V (default), 4...20 mA w/ ZG-R01 (500 Ω, 1/4 W resistor), variable (VDC, on/off, floating point)
Operating range Y variable	Start point 0.5...30 V End point 2.5...32 V
Input Impedance	100 kΩ for 2...10 V (0.1 mA), 500 Ω for 4...20 mA, 1500 Ω for PWM, On/Off and Floating point
Position Feedback	2...10 V
Angle of rotation	Max. 95°, adjustable with mechanical stop
Torque motor	360 in-lb [40 Nm]
Direction of motion motor	selectable with switch 0/1
Position indication	Mechanically, 5...20 mm stroke
Manual override	external push button
Running Time (Motor)	default 150 s, variable 45...170 s
Ambient humidity	max. 95% r.H., non-condensing
Ambient temperature	-22...122°F [-30...50°C]
Storage temperature	-40...176°F [-40...80°C]
Degree of Protection	IP66, NEMA 4X, UL Enclosure Type 4X
Housing material	Polycarbonate
Agency Listing	cULus acc. to UL60730-1A/-2-14, CAN/CSA E60730-1, CSA C22.2 No 24-93, CE acc. to 89/336/EC
Noise level, motor	45 dB(A)
Servicing	maintenance-free
Quality Standard	ISO 9001
Weight	7.1 lb [3.2 kg]

†Rated Impulse Voltage 800V, Type action 1, Control Pollution Degree 3.

Torque min. 360 in-lb, for control of damper surfaces up to 90 sq. ft.

Application

For modulation of dampers in HVAC systems. Actuator sizing should be done in accordance with the damper manufacturer's specifications. The actuator is mounted directly to a damper shaft up to 1.05" in diameter by means of its universal clamp. The default parameters for 2 to 10 VDC applications of the ... MFT actuator are assigned during manufacturing. If necessary, custom versions of the actuators can be ordered. The parameters can be changed by two means: pre-set and custom configurations from Belimo or on-site configurations using the Belimo PC-Tool software.

Operation

The actuator is not provided with and does not require any limit switches, but is electronically protected against overload. The anti-rotation strap supplied with the actuator will prevent lateral movement.

The GMB24-SR-T N4 provides 95° of rotation and a visual indicator indicates position of the actuator. When reaching the damper or actuator end position, the actuator automatically stops. The gears can be manually disengaged with a button on the actuator after the cover is removed.

The GMB24-SR-T N4 actuator uses a sensorless brushless DC motor, which is controlled by an Application Specific Integrated Circuit (ASIC). The ASIC monitors and controls the actuator's rotation and provides a digital rotation sensing (DRS) function to prevent damage to the actuator in a stall condition. Power consumption is reduced in holding mode.

Add-on auxiliary switches or feedback potentiometers are easily fastened directly onto the actuator body for signaling and switching functions.

For low ambient temperatures, the optional supplemental (-H) Heater add-on is available.

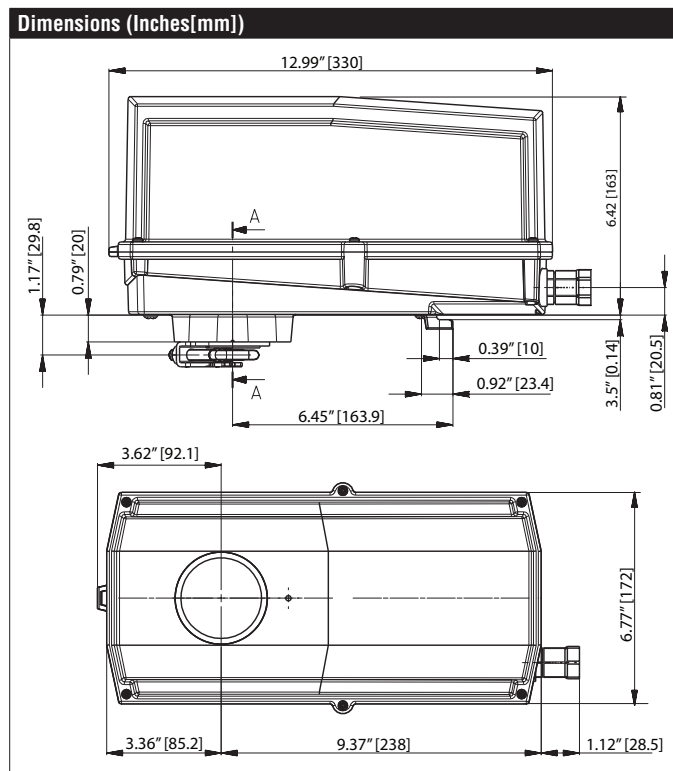

Date created, 02/10/2020 - Subject to change. © Belimo Aircontrols (USA), Inc.

Accessories	
AH-GMA	Actuator arm
AV8-25	Shaft extension
KG8	Ball joint
K-GM20	Standard GK/GM clamp (1/2" to 1.05").
SH10	Push rod for KG10A ball joint (36" L, 3/8" diameter).
SH8	Push rod for KG6 & KG8 ball joints (36" L, 5/16" diameter).
TF-CC US	Cable conduit connector, 1/2".
TOOL-07	13 mm wrench.
ZG-100	Univ. right angle bracket 17"x11-1/8"x6" (HxWxbase).
ZG-101	Univ. right angle bracket 13x11x7-7/16" (HxWxbase).
ZG-102	Dual actuator mounting bracket.
ZG-103	Univ. right angle bracket 7-1/2x11x2-3/4" (HxWxbase).
ZG-104	Univ. right angle bracket 13-5/8x7-1/2x4" (HxWxbase).
ZG-109	Right angle bracket for ZS-260.
ZG-110	Stand-off bracket for ZS-260.
ZG-DC1	Damper clip for damper blade, 3.5" width.
ZG-DC2	Damper clip for damper blade, 6" width.
ZG-GMA	Mounting kit for linkage operation
Z-GMA	Base plate extension
ZK1-GEN	Connection cable
ZK2-GEN	Connection cable
ZS-100	Weather shield - galvaneal 13x8x6" (LxWxD).
ZS-101	Base plate for ZS-100.
ZS-150	Weather shield - PC w/ foam seal 16x8-3/8x4" (LxWxD).
ZS-260	Explosion proof housing.
ZS-300	NEMA 4X, 304 stainless steel enclosure.
ZS-300-5	NEMA 4X, 316L stainless steel enclosure.
ZS-300-C1	1/2" shaft adaptor, standard with ZS-300(-5).
ZS-300-C2	3/4" shaft adaptor for ZS-300(-5).
ZS-300-C3	1" shaft adaptor for ZS-300(-5).
MFT-P	Belimo PC-Tool
11097-00001	Gasket for cable gland (for NEMA 4 models).
43442-00001	Cable gland (for NEMA 4 models).
SGF24	Positioners suitable for use with the modulating damper actuators LM..A-SR, NM..A-SR, SM..A-SR and GM..A-SR
ZG-R01	4 to 20 mA adaptor, 500Ω, 1/4 W resistor w 6" pigtail wires.
SGA24	Positioners suitable for use with the modulating damper actuators LM..A-SR, NM..A-SR, SM..A-SR and GM..A-SR
P1000A GR	Feedback potentiometer for damper actuators and rotary actuators
S2A	Auxiliary switch for damper actuators and rotary actuators
S1A	Auxiliary switch for damper actuators and rotary actuators
NSV24 US	Battery back-up module for non-spring return actuators.
ZG-X40	120 to 24 VAC, 40 VA transformer.

Typical Specification

Floating point, on/off control damper actuators shall be electronic direct-coupled type, which require no crank arm and linkage and be capable of direct mounting to a shaft up to 1.05" diameter. Actuators shall have brushless DC motor technology and be protected from overload at all angles of rotation. Actuators shall have reversing switch and manual override on the cover. Run time shall be constant and independent of torque. Actuators shall be cULus listed, have a 5-year warranty, and be manufactured under ISO 9001 International Quality Control Standards. Actuators shall be as manufactured by Belimo.

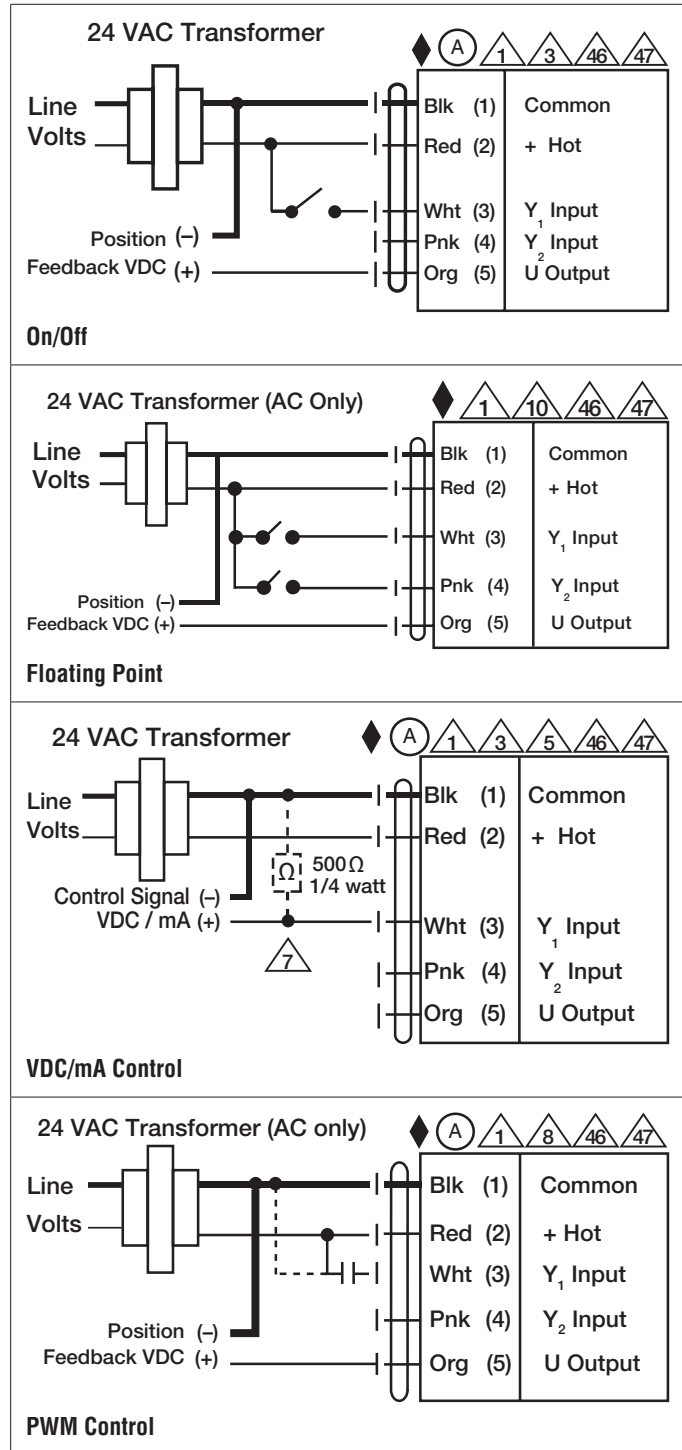

GMX24-MFT N4 Technical Data Sheet

NEMA 4X, Modulating Control, Non-Spring Return, Direct Coupled,
24 V, Multi-Function Technology®



Wiring Diagrams

- A Actuators with appliance cables are numbered.
- 1 Provide overload protection and disconnect as required.
- 3 Actuators may also be powered by 24 VDC.
- 5 Only connect common to negative (-) leg of control circuits.
- 7 A 500 Ω resistor (ZG-R01) converts the 4 to 20 mA control signal to 2 to 10 VDC.
- 8 Control signal may be pulsed from either the Hot (Source) or Common (Sink) 24 VAC line.
- 10 For triac sink the Common connection from the actuator must be connected to the Hot connection of the controller. Position feedback cannot be used with a triac sink controller; the actuator internal common reference is not compatible.
- 12 IN4004 or IN4007 diode. (IN4007 supplied, Belimo part number 40155).
- 46 Actuators may be controlled in parallel. Current draw and input impedance must be observed.
- 47 Master-Slave wiring required for piggy-back applications. Feedback from Master to control input(s) of Slave(s).

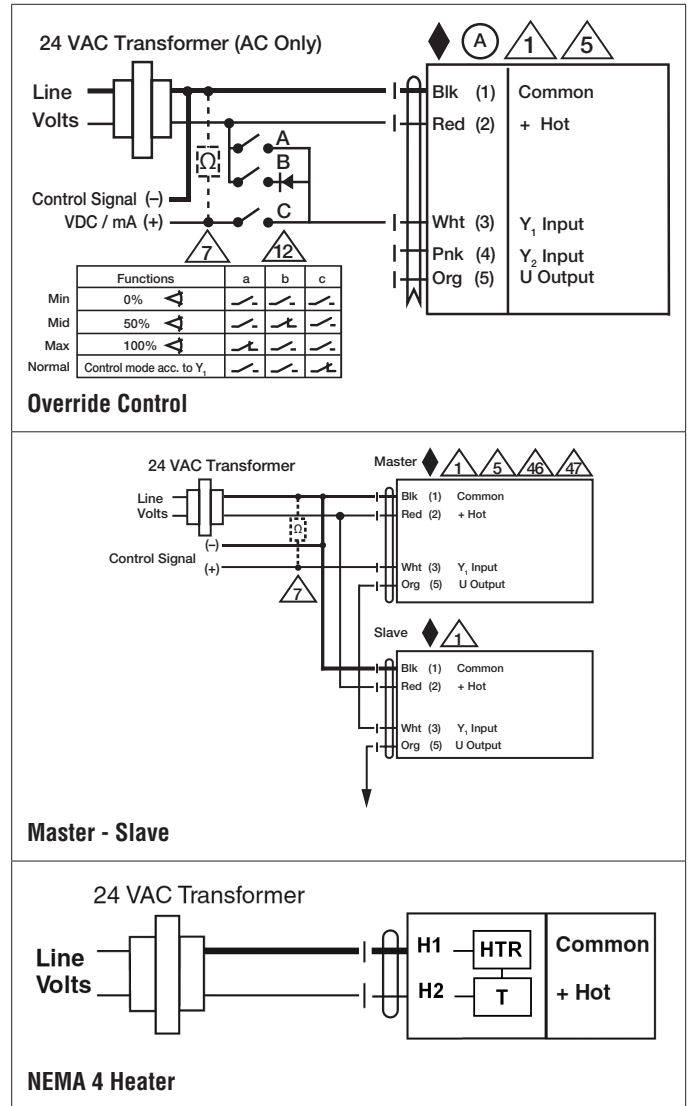

Date created, 02/10/2020 - Subject to change. © Belimo Aircontrols (USA), Inc.