

Rack-mounted DCS Signal Conditioners 18K-RACK

STANDARD RACK

Functions & Features

- Standard 19" rack for 18K-RACK signal conditioners
- 18-Rack signal conditioners are also mountable
- Module can be retracted without removing wiring for an insulation test
- Line power supplied via the rear rack bus
- Direct interface to various DCS with the rack side connector

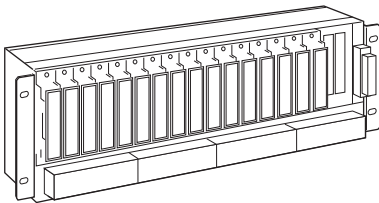

MODEL: 18KBXC-[1][2]

ORDERING INFORMATION

- Code number: 18KBXC-[1][2]
- Specify a code from below for each [1] and [2].
(e.g. 18KBXC-Y1/W)

[1] CONNECTOR

- 0:** None
U1: Fujitsu FCN type I/O connector
Y1: Yokogawa DCS MAC2 / PAC card use
Y2: Yokogawa DCS VMx / PM1 card use
Y3: Yokogawa DCS for Module
• AAB841 (Adapter: ATV4A, Cable: KS2)
E4: Toshiba DCS VTBU card use
K1: Yamatake DCS AI connector
K2: Yamatake DCS AO connector
K5: Yamatake DCS PI connector
M-System guarantees the connecting section.

[2] OPTIONS

Mounting Bracket

- blank:** Rack mounting, standard
/W: Surface mounting

RELATED PRODUCTS

- Blank filler plate (model: P-181)
- Connector terminal block (model: CNT)
- Special cable with 40-pin connector (model: FCN)

GENERAL SPECIFICATIONS

Construction: Metal plates assembly

Coating: Colored Zn-Cr

Capacity: 16 positions

Connection

Power input: M4 screw terminals (torque 0.8 N·m)

Field terminal: M3.5 screw terminals (torque 0.8 N·m)

Screw terminal

Power: Nickel-plated brass

Field terminal: Nickel-plated steel

Isolation: I/O connector to field terminal to power to FG

INSTALLATION

Power input

- **DC:** Operating voltage range 24 V DC $\pm 10\%$, 2.5 A minimum (ripple 10 % p-p max.)

Operating temperature: -5 to +55°C (23 to 131°F)

Operating humidity: 30 to 90 %RH (non-condensing)

Mounting: JIS or EIA standard rack or surface

Weight: 2.7 kg (5.95 lb)

PERFORMANCE

Insulation resistance: $\geq 100\text{ M}\Omega$ with 500 V DC

Dielectric strength: 500 V AC @ 1 minute

(I/O connector to field terminal to power)

1000 V AC @ 1 minute (I/O connector or field terminal or power to FG)

MOUNTING REQUIREMENTS unit: mm (inch)

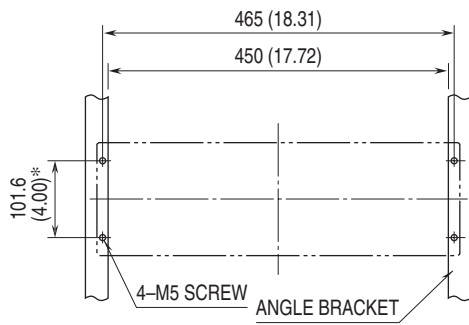

Observe an appropriate wiring space over and below.
*100 (3.94) for JIS standard

CONNECTION DIAGRAM

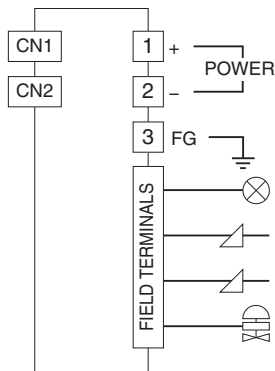

Note 1: CN1 and CN2 are not available without connector.

Note 2: CN2 is only available with

- Fujitsu FCN type I/O connector
- Yokogawa DCS MAC2 / PAC card use
- Yokogawa DCS for Module / AAB841 (Adapter: ATV4A, Cable: KS2)
- Yamatake DCS PI connector

DIMENSIONS unit: mm (inch)

■ RACK (standard)

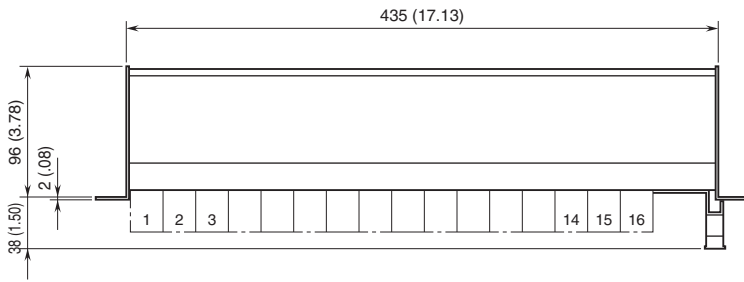

■ SURFACE (option /W)

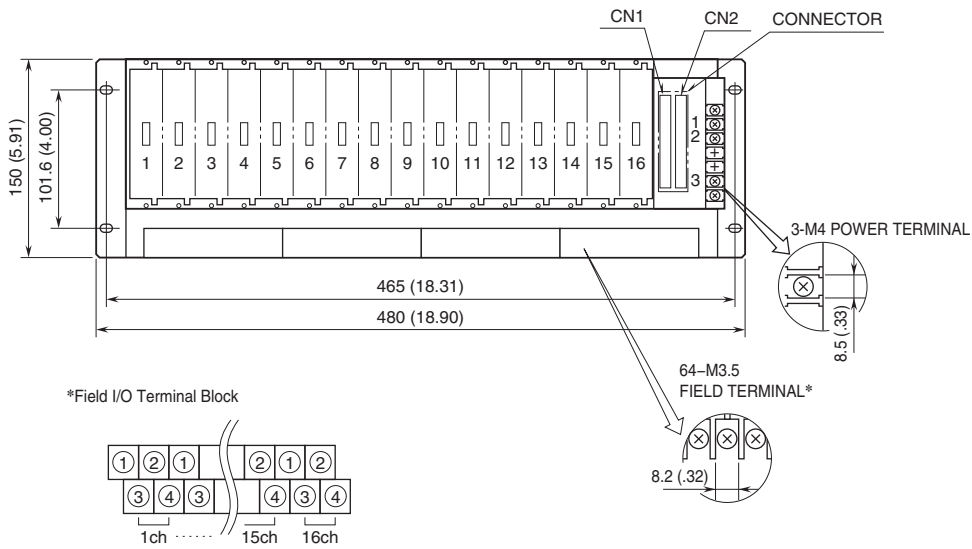
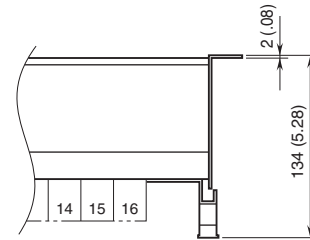

I/O CONNECTOR PIN ASSIGNMENT

•Fujitsu FCN type I/O connector

(Fujitsu FCN-365P040-AU)

Connector Pin Assignment

CN1: output 1 or input

CN2: output 2

PIN NO.	ASSIGNMENT	PIN NO.	ASSIGNMENT
A 1	ch. 1 +	B 1	ch. 1 -
A 2	ch. 2 +	B 2	ch. 2 -
A 3	ch. 3 +	B 3	ch. 3 -
A 4	ch. 4 +	B 4	ch. 4 -
A 5	ch. 5 +	B 5	ch. 5 -
A 6	ch. 6 +	B 6	ch. 6 -
A 7	ch. 7 +	B 7	ch. 7 -
A 8	ch. 8 +	B 8	ch. 8 -
A 9	ch. 9 +	B 9	ch. 9 -
A10	ch.10 +	B10	ch.10 -
A11	ch.11 +	B11	ch.11 -
A12	ch.12 +	B12	ch.12 -
A13	ch.13 +	B13	ch.13 -
A14	ch.14 +	B14	ch.14 -
A15	ch.15 +	B15	ch.15 -
A16	ch.16 +	B16	ch.16 -

A17 - A20, B17 - B20: Unused

Pin assignment is common to both CN1 and CN2.

•Yokogawa DCS MAC2 / PAC card use

(PS-40PE-D4LT1-PN1)

Location

CN1: MAC2 / PAC card use*

CN2: MAC2 / PAC card use* (for redundancy)

The input or output 1 is connected to the connector.

18K-RACK LOCATION NO.															
1	2	3	4	5	6	7	8	9	10	11	12	13	14	15	16
1	1	2	2	3	3	4	4	5	5	6	6	7	7	8	8
i	o	i	o	i	o	i	o	i	o	i	o	i	o	i	o
MAC2/PAC CARD I/O (i = input, o = output)															

*MAC2 card (uses KS1 cable)

I/O card used for control I/O. Composed of 8 inputs and 8 outputs. Input and output are paired. (Replace with pulse inputs for PAC card.)

•Yokogawa DCS VMx / PM1 card use

(PS-40PE-D4LT1-PN1)

Location

CN1: VMx / PM1 card use*

The input or output 1 is connected to the connector.

18K-RACK LOCATION NO.															
1	2	3	4	5	6	7	8	9	10	11	12	13	14	15	16
1	2	3	4	5	6	7	8	9	10	11	12	13	14	15	16
VM1/PM1/VM4 CARD INPUT or OUTPUT															
1	2	3	4	5	6	7	8	1	2	3	4	5	6	7	8
VM2 CARD INPUT NO.								VM2 CARD OUTPUT NO.							

*VMx / PM1 card (uses KS2 cable)

VM1: analog input 16 points

VM2: analog input 8 points / analog output 8 points

VM4: analog output 16 points

PM1: pulse input 16 points

•Yokogawa DCS for Module

AAB841 module (Adapter: ATV4A, Cable: KS2)*
(PS-40PE-D4LT1-PN1)

Location

CN1: Single

CN2: Unused* *

The input or output 1 is connected to the connector.
The CN1 and CN2 are connected in parallel.

18K-RACK LOCATION NO.															
1	2	3	4	5	6	7	8	9	10	11	12	13	14	15	16
1	2	3	4	5	6	7	8	1	2	3	4	5	6	7	8
AAB841 module INPUT NO.								AAB841 module OUTPUT NO.							

Connector Pin Assignment (CN1, CN2)

PIN NO.	ASSIGNMENT	PIN NO.	ASSIGNMENT
40	ch. 1 +	24	ch. 9 +
39	ch. 1 -	23	ch. 9 -
38	ch. 2 +	22	ch.10 +
37	ch. 2 -	21	ch.10 -
36	ch. 3 +	20	ch.11 +
35	ch. 3 -	19	ch.11 -
34	ch. 4 +	18	ch.12 +
33	ch. 4 -	17	ch.12 -
32	ch. 5 +	16	ch.13 +
31	ch. 5 -	15	ch.13 -
30	ch. 6 +	14	ch.14 +
29	ch. 6 -	13	ch.14 -
28	ch. 7 +	12	ch.15 +
27	ch. 7 -	11	ch.15 -
26	ch. 8 +	10	ch.16 +
25	ch. 8 -	9	ch.16 -

1 - 8: Unused

*I/O module

AAB841: Analog I/O module

(1 - 5 V input, 4 - 20 mA output,

input 8 points / output 8 points, non-isolated)

**Not available for redundancy

•Toshiba DCS VTBU card use (57LE-40360-7700)

Connector Pin Assignment

CN1: VTBU card use

The output 1 is connected to the connector.

PIN NO.	ASSIGNMENT	PIN NO.	ASSIGNMENT
1	ch. 1 +	19	ch. 1 -
2	ch. 2 +	20	ch. 2 -
3	ch. 3 +	21	ch. 3 -
4	ch. 4 +	22	ch. 4 -
5	ch. 5 +	23	ch. 5 -
6	ch. 6 +	24	ch. 6 -
7	ch. 7 +	25	ch. 7 -
8	ch. 8 +	26	ch. 8 -
9	ch. 9 +	27	ch. 9 -
10	ch.10 +	28	ch.10 -
11	ch.11 +	29	ch.11 -
12	ch.12 +	30	ch.12 -
13	ch.13 +	31	ch.13 -
14	ch.14 +	32	ch.14 -
15	ch.15 +	33	ch.15 -
16	ch.16 +	34	ch.16 -

17, 18, 35 and 36: Unused

•Yamatake DCS AI connector

Location

Input connector: 57LE-40500-7300

CN1: AI use

18K-RACK LOCATION NO.															
1	2	3	4	5	6	7	8	9	10	11	12	13	14	15	16
YAMATAKE DCS AI CARD (J-HAM50/HMM00) INPUT															

•Yamatake DCS AO connector

Location

Output connector: 57LE-40500-7300

CN1: AO use

18K-RACK LOCATION NO.															
1	2	3	4	5	6	7	8	9	10	11	12	13	14	15	16
YAMATAKE DCS AO CARD (J-AOM10) OUTPUT															

Connector Pin Assignment (CN1)

1 and 2, 48 and 49 in CN1 are connected.

The input is connected to the connector.

PIN NO.	ASSIGNMENT	PIN NO.	ASSIGNMENT
3	ch. 1 +	11	ch. 9 +
4	ch. 1 -	12	ch. 9 -
5	ch. 2 +	13	ch.10 +
6	ch. 2 -	14	ch.10 -
7	ch. 3 +	15	ch.11 +
8	ch. 3 -	16	ch.11 -
9	ch. 4 +	17	ch.12 +
10	ch. 4 -	18	ch.12 -
27	ch. 5 +	19	ch.13 +
26	ch. 5 -	20	ch.13 -
29	ch. 6 +	21	ch.14 +
28	ch. 6 -	22	ch.14 -
31	ch. 7 +	23	ch.15 +
30	ch. 7 -	24	ch.15 -
33	ch. 8 +	25	ch.16 +
32	ch. 8 -	50	ch.16 -

34 - 37 (CN1): Unused

•Yamatake DCS PI connector

Location

Output connector: 57LE-40500-7300

CN1, CN2: PI use

18K-RACK LOCATION NO.															
1	2	3	4	5	6	7	8	9	10	11	12	13	14	15	16
CN1 YAMATAKE DCS PI CARD (J-PIM00) INPUT								CN2 YAMATAKE DCS PI CARD (J-PIM00) INPUT							

Connector Pin Assignment (CN1, CN2)

1, 36, 38, 39, 41, 42, 43 and 45 in CN1 and CN2 are connected.

2, 34, 35, 37, 40, 44, 46 and 47 in CN1 and CN2 are connected.

48 and 49 in CN1 and CN2 are connected.

The output 1 is connected to the connector.

PIN NO. (CN1)	ASSIGNMENT	PIN NO. (CN2)	ASSIGNMENT
3	ch. 1 +	3	ch. 9 +
4	ch. 1 -	4	ch. 9 -
5	ch. 2 +	5	ch.10 +
6	ch. 2 -	6	ch.10 -
7	ch. 3 +	7	ch.11 +
8	ch. 3 -	8	ch.11 -
9	ch. 4 +	9	ch.12 +
10	ch. 4 -	10	ch.12 -
27	ch. 5 +	27	ch.13 +
26	ch. 5 -	26	ch.13 -
29	ch. 6 +	29	ch.14 +
28	ch. 6 -	28	ch.14 -
31	ch. 7 +	31	ch.15 +
30	ch. 7 -	30	ch.15 -
33	ch. 8 +	33	ch.16 +
32	ch. 8 -	32	ch.16 -

11 - 25 and 50 (CN1, CN2): Unused



Specifications are subject to change without notice.