

## General Description

The IDT8T79S838-08I is a high performance, 1-to-8, differential input to universal output fanout buffer. The device is designed for signal fanout of high-frequency clock signals in applications requiring output frequencies generated simultaneously. The IDT8T79S838-08I is optimized for 3.3V and 2.5V supply voltages and a temperature range of -40°C to 85°C. The device is packaged in a space-saving 32 lead VFQFN package.

## Features

- Four banks of two output pairs
- Individual output type control, LVDS or LVPECL, via serial interface
- Individual outputs remain enabled while serial loading new device configurations
- One differential PCLK, nPCLK input
- PCLK, nPCLK input pair can accept the following differential input levels: LVPECL, LVDS levels
- Maximum input frequency: 1.5GHz
- LVCMOS control inputs
- Individual output enable/disable control via serial interface
- 2.375V to 3.465V supply voltage operation
- -40°C to 85°C ambient operating temperature
- Lead-free (RoHS 6) packaging

## Block Diagram

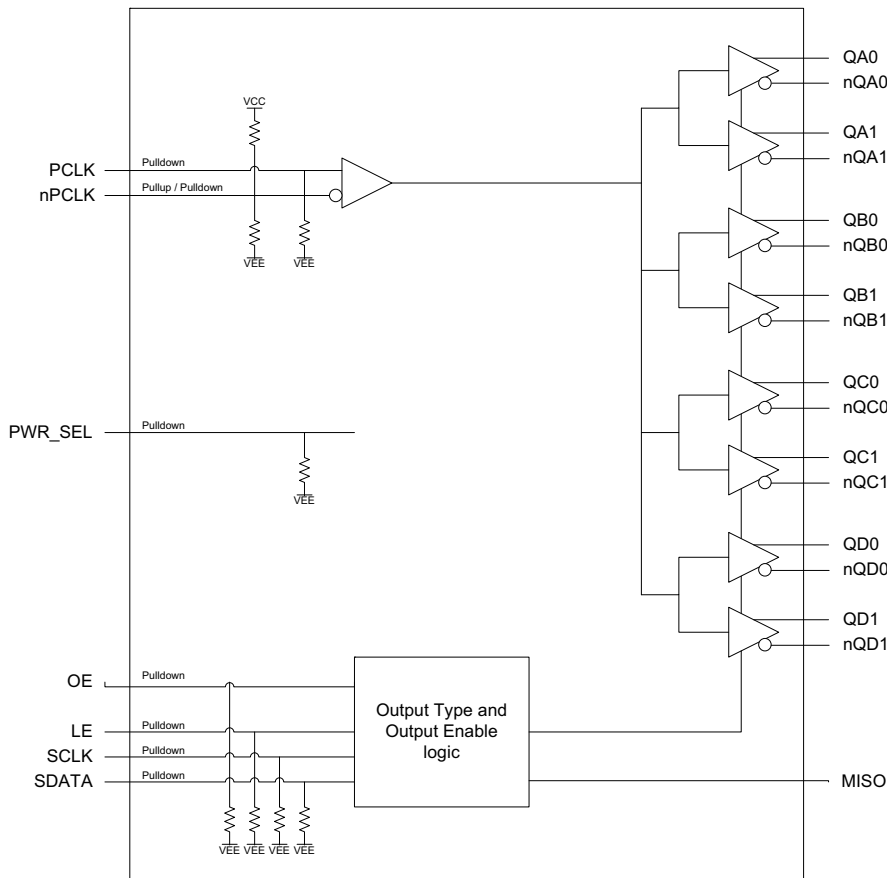

## Pin Assignment

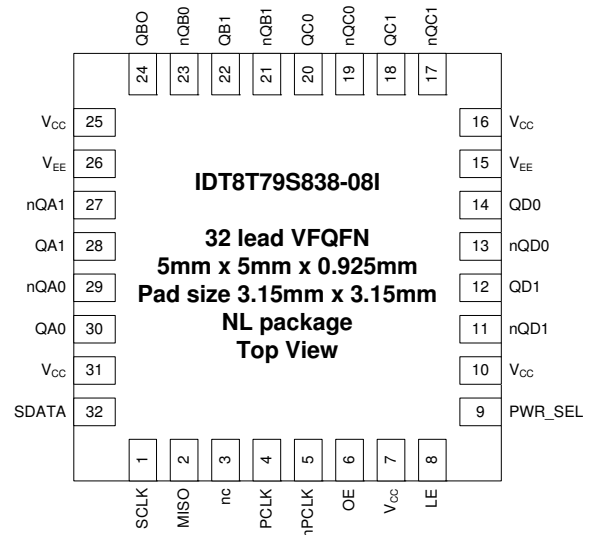

## Pin Description and Pin Characteristic Tables

**Table 1. Pin Descriptions**

Number	Name	Type		Description
1	SCLK	Input	Pulldown	Serial Control Port Mode Data Input. LVCMOS/LVTTL interface levels.
2	MISO	Output		Serial Control Port Mode Data Output. LVCMOS/LVTTL interface levels.
3	nc	Unused		No connect.
4	PCLK	Input	Pulldown	Non-inverting differential clock input.
5	nPCLK	Input	Pullup / Pulldown	Inverting differential clock input. $V_{CC} / 2$ by default when left floating.
6	OE	Input	Pulldown	Default output disable. LVCMOS/LVTTL interface levels. See "Table 3B. OE Truth Table".
7, 10, 16, 25, 31	$V_{CC}$	Power		Power supply voltage pin.
8	LE	Input	Pulldown	Serial Control Port Mode Enable. Latches data when the pin gets a high level. Outputs remain enabled when LE is low. LVCMOS/LVTTL interface levels.
9	PWR_SEL	Input	Pulldown	Power supply selection. See "Table 3A. PWR_SEL Truth Table".
11, 12	nQD1, QD1	Output		Differential Bank D output pair.
13, 14	nQD0, QD0	Output		Differential Bank D output pair.
15, 26	$V_{EE}$	Power		Negative power supply pins.
17, 18	nQC1, QC1	Output		Differential Bank C output pair. LVPECL or LVDS interface levels.
19, 20	nQC0, QC0	Output		Differential Bank C output pair. LVPECL or LVDS interface levels.
21, 22	nQB1, QB1	Output		Differential Bank B output pair. LVPECL or LVDS interface levels.
23, 24	nQB0, QB0	Output		Differential Bank B output pair. LVPECL or LVDS interface levels.
27, 28	nQA1, QA1	Output		Differential Bank A output pair. LVPECL or LVDS interface levels.
29, 30	nQA0, QA0	Output		Differential Bank A output pair. LVPECL or LVDS interface levels.
32	SDATA	Input	Pulldown	Serial Control Port Mode Data Input. LVCMOS/LVTTL interface levels.

NOTE: Pullup and Pulldown refer to internal input resistors. See "Table 2. Pin Characteristics" for typical values.

**Table 2. Pin Characteristics**

Symbol	Parameter		Test Conditions	Minimum	Typical	Maximum	Units
$C_{IN}$	Input Capacitance				2		pF
$R_{PULLDOWN}$	Input Pulldown Resistor				51		k $\Omega$
$R_{PULLUP}$	Input Pullup Resistor				51		k $\Omega$
$R_{OUT}$	Output Impedance	MISO	$V_{CC} = 3.3V$		125		$\Omega$
			$V_{CC} = 2.5V$		125		$\Omega$

## Function Tables

**Table 3A. PWR\_SEL Truth Table**

PWR_SEL	Function
L (Connect to $V_{EE}$ )	2.5V power supply
H (Connect to $V_{CC}$ )	3.3V power supply

**Table 3B. OE Truth Table**

OE	Function
L (default)	All outputs disabled (Low/High static mode), regardless of individual OE registers set by Serial Interface.
H	Outputs enabled according to individual OE registers set by Serial Interface (see “ <a href="#">Table 3E. Configuration Table</a> ”).

## Output Type Control and Start-up Status

Two output types are available: LVDS and LVPECL. The part features four modes of output type control:

- Eight LVDS outputs
- Eight LVPECL outputs
- Two LVDS (QA<sub>x</sub>) + six LVPECL (QB<sub>x</sub>, QC<sub>x</sub>, QD<sub>x</sub>)
- Two LVPECL (QA<sub>x</sub>) + six LVDS (QB<sub>x</sub>, QC<sub>x</sub>, QD<sub>x</sub>)

At startup, the outputs are in static Low/High LVDS mode until the part has been configured. Disabled outputs are in static Low/High mode. A global hardware Output Enable (OE pin #6) enables or disables all outputs at once. The global hardware OE has priority over a serial interface configuration.

**Table 3C. Output Type Control**

Control Bits		Output Configuration
D2	D1	
LOW	LOW	8 LVDS Outputs
HIGH	HIGH	8 LVPECL Outputs
HIGH	LOW	2 LVDS (QA <sub>x</sub> ) + 6 LVPECL (QB <sub>x</sub> , QC <sub>x</sub> , QD <sub>x</sub> ) Outputs
LOW	HIGH	2 LVPECL (QA <sub>x</sub> ) + 6 LVDS (QB <sub>x</sub> , QC <sub>x</sub> , QD <sub>x</sub> ) Outputs

## Serial Interface

Configuration of the IDT8T79S838I-08 is achieved by writing 10 configuration bits over serial interface. All 10 bits have to be written in sequence.

After writing the 10 configuration bits, the LE pin must remain at high level for outputs to toggle.

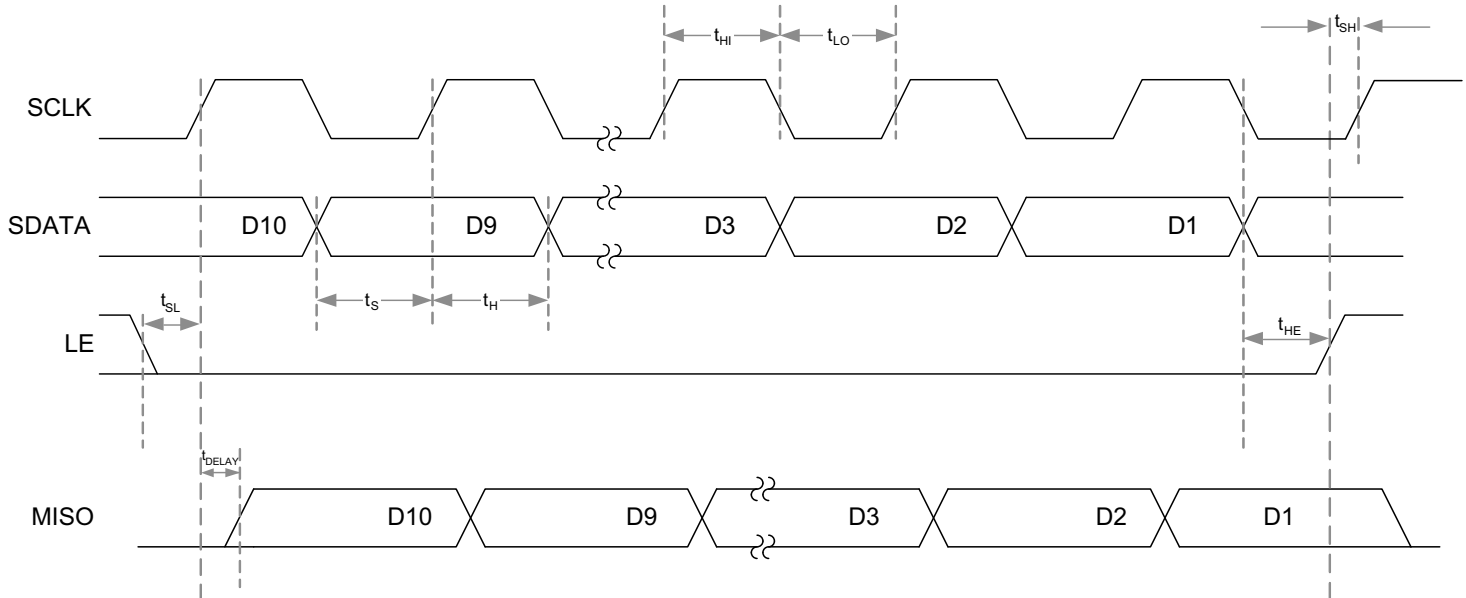

Figure 1. Serial Interface Timing Diagram for Write and Read Access

Table 3D. Timing AC Characteristics

Symbol	Parameter	Test Conditions	Minimum	Typical	Maximum	Units
$t_S$	Data to Clock Setup Time		10			ns
$t_H$	Data to Clock Hold Time		10			ns
$t_{HE}$	Clock to LE Hold Time		10			ns
$t_{HI}$	Clock High Duration		25			ns
$t_{LO}$	Clock Low Duration		25			ns
$t_{SL}$	LE to Clock Setup Time		10			ns
$t_{SH}$	LE to SCLK Setup Time		10			ns
$t_{DELAY}$	Clock to MISO Delay Time				10	ns

NOTE: Electrical parameters are guaranteed over the specified ambient operating temperature range, which is established when the device is mounted in a test socket with maintained transverse airflow greater than 500 lpm. The device will meet specifications after thermal equilibrium has been reached under these conditions.

**Table 3E. Configuration Table**

Bit	Name	Function	Truth Table
D10	oed1	Output Enable QD1	Low: Disabled High: Enabled
D9	oed0	Output Enable QD0	
D8	oec1	Output Enable QC1	
D7	oec0	Output Enable QC0	
D6	oeb1	Output Enable QB1	
D5	oeb0	Output Enable QB0	
D4	oea1	Output Enable QA1	
D3	oea0	Output Enable QA0	
D2	ot1	Banks QB, QC, QD Output Type	Low: LVDS High: LVPECL
D1	ot0	Bank QA Output Type	

## Absolute Maximum Ratings

NOTE: Stresses beyond those listed under *Absolute Maximum Ratings* may cause permanent damage to the device. These ratings are stress specifications only. Functional operation of product at these conditions or any conditions beyond those listed in the *DC Characteristics* or *AC Characteristics* is not implied. Exposure to absolute maximum rating conditions for extended periods may affect product reliability.

Item	Rating
Supply Voltage, $V_{CC}$	4.6V
Inputs, $V_I$	-0.5V to $V_{CC} + 0.5V$
Outputs, $V_O$ (LVCMOS)	-0.5V to $V_{CC} + 0.5V$
Outputs, $I_O$ (LVPECL) Continuous Current Surge Current	50mA 100mA
Outputs, $I_O$ (LVDS) Continuous Current Surge Current	10mA 15mA
Package Thermal Impedance, $\theta_{JA}$	48.9°C/W (0 mps)
Storage Temperature, $T_{STG}$	-65°C to 150°C

## DC Electrical Characteristics

**Table 4A. Power Supply DC Characteristics,  $V_{CC} = 3.3V \pm 5\%$ ,  $V_{EE} = 0V$ ,  $T_A = -40^\circ C$  to  $85^\circ C$**

Symbol	Parameter	Test Conditions	Minimum	Typical	Maximum	Units
$V_{CC}$	Power Supply Voltage		3.135	3.3	3.465	V
$I_{EE}$	Power Supply Current	D[10:1] = HIGH, LVPECL		120	135	mA
$I_{CC}$	Power Supply Current	D[10:3] = HIGH; D[2:1] = LOW, LVDS		215	235	mA

**Table 4B. Power Supply DC Characteristics,  $V_{CC} = 2.5V \pm 5\%$ ,  $V_{EE} = 0V$ ,  $T_A = -40^\circ C$  to  $85^\circ C$**

Symbol	Parameter	Test Conditions	Minimum	Typical	Maximum	Units
$V_{CC}$	Power Supply Voltage		2.375	2.5	2.625	V
$I_{EE}$	Power Supply Current	D[10:1] = HIGH, LVPECL		114	125	mA
$I_{CC}$	Power Supply Current	D[10:3] = HIGH; D[2:1] = LOW, LVDS		210	230	mA

**Table 4C. LVCMOS/LVTTL DC Characteristics,  $V_{CC} = 3.3V \pm 5\%$  or  $2.5V \pm 5\%$ ,  $V_{EE} = 0V$ ,  $T_A = -40^\circ C$  to  $85^\circ C$** 

Symbol	Parameter		Test Conditions	Minimum	Typical	Maximum	Units
$V_{IH}$	Input High Voltage		$V_{CC} = 3.3V$	2.2		$V_{CC} + 0.3$	V
			$V_{CC} = 2.5V$	1.7		$V_{CC} + 0.3$	V
$V_{IL}$	Input Low Voltage		$V_{CC} = 3.3V$	-0.3		0.8	V
			$V_{CC} = 2.5V$	-0.3		0.7	V
$I_{IH}$	Input High Current	OE, LE, PWR_SEL, SCLK, SDATA	$V_{CC} = V_{IN} = 3.465V$ or $2.625V$			150	$\mu A$
$I_{IL}$	Input Low Current	OE, LE, PWR_SEL, SCLK, SDATA	$V_{CC} = 3.465V$ or $2.625V$ , $V_{IN} = 0V$	-10			$\mu A$
$V_{OH}$	Output High Voltage	MISO	$V_{CC} = 3.465V$ , $I_{OH} = -1mA$	2.6			V
			$V_{CC} = 2.625V$ , $I_{OH} = -1mA$	1.8			V
$V_{OL}$	Output Low Voltage	MISO	$V_{CC} = 3.465V$ or $2.625V$ , $I_{OL} = 1mA$			0.5	V

**Table 4D. Differential Input DC Characteristics,  $V_{CC} = 3.3V \pm 5\%$  or  $2.5V \pm 5\%$ ,  $V_{EE} = 0V$ ,  $T_A = -40^\circ C$  to  $85^\circ C$** 

Symbol	Parameter		Test Conditions	Minimum	Typical	Maximum	Units
$I_{IH}$	Input High Current	PCLK, nPCLK	$V_{CC} = V_{IN} = 3.465V$ or $2.625V$			150	$\mu A$
$I_{IL}$	Input Low Current	PCLK	$V_{CC} = 3.465V$ or $2.625V$ , $V_{IN} = 0V$	-10			$\mu A$
		nPCLK	$V_{CC} = 3.465V$ or $2.625V$ , $V_{IN} = 0V$	-150			$\mu A$
$V_{PP}$	Peak-to-Peak Voltage			0.15		1.3	V
$V_{CMR}$	Common Mode Input Voltage; NOTE 1			1.0		$V_{CC} - 0.5$	V

NOTE 1: Common mode input voltage is defined at the cross point.

**Table 4E. LVPECL DC Characteristics,  $V_{CC} = 3.3V \pm 5\%$  or  $2.5V \pm 5\%$ ,  $V_{EE} = 0V$ ,  $T_A = -40^\circ C$  to  $85^\circ C$** 

Symbol	Parameter	Test Conditions	Minimum	Typical	Maximum	Units
$V_{OH}$	Output High Voltage; NOTE 1		$V_{CC} - 1.3$		$V_{CC} - 0.75$	V
$V_{OL}$	Output Low Voltage; NOTE 1		$V_{CC} - 2.0$		$V_{CC} - 1.6$	V
$V_{SWING}$	Peak-to-Peak Output Voltage Swing		0.6		1.0	V

NOTE 1: Outputs terminated with  $50\Omega$  to  $V_{CC} - 2V$ .

**Table 4F. LVDS DC Characteristics,  $V_{CC} = 3.3V \pm 5\%$  or  $2.5V \pm 5\%$ ,  $V_{EE} = 0V$ ,  $T_A = -40^\circ C$  to  $85^\circ C$** 

Symbol	Parameter	Test Conditions	Minimum	Typical	Maximum	Units
$V_{OD}$	Differential Output Voltage		247		454	mV
$\Delta V_{OD}$	$V_{OD}$ Magnitude Change				50	mV
$V_{OS}$	Offset Voltage		1.125		1.45	V
$\Delta V_{OS}$	$V_{OS}$ Magnitude Change				50	mV

## AC Electrical Characteristics

**Table 5. AC Characteristics,  $V_{CC} = 3.3V \pm 5\%$  or  $2.5V \pm 5\%$ ,  $V_{EE} = 0V$ ,  $T_A = -40^\circ C$  to  $85^\circ C$**

Symbol	Parameter		Test Conditions	Minimum	Typical	Maximum	Units
$f_{IN}$	Input Frequency	PCLK, nPCLK				1.5	GHz
$f_{OUT}$	Output Frequency	Qx, nQx				1.5	GHz
$t_{PD}$	Propagation Delay; NOTE 5	LVPECL		200		650	ps
		LVDS		200		650	ps
$t_{sk(o)}$	Output Skew; NOTE 1, 2	LVPECL				80	ps
		LVDS				80	ps
$t_{sk(b)}$	Bank Skew; NOTE 1, 3	LVPECL				55	ps
		LVDS				55	ps
$t_{sk(pp)}$	Part-to-Part Skew; NOTE 1, 4	LVPECL				450	ps
		LVDS				450	ps
$t_R / t_F$	Output Rise/Fall Time	LVPECL	20% to 80%	50		300	ps
		LVDS	20% to 80%	50		300	ps
odc	Output Duty Cycle	LVPECL		40		60	%
		LVDS		40		60	%

NOTE: Electrical parameters are guaranteed over the specified ambient operating temperature range, which is established when the device is mounted in a test socket with maintained transverse airflow greater than 500 lpm. The device will meet specifications after thermal equilibrium has been reached under these conditions.

NOTE 1: This parameter is defined in accordance with JEDEC Standard 65.

NOTE 2: Defined as skew between outputs at the same supply voltage and with equal load conditions. Measured at the differential crosspoints.

NOTE 3: Defined as skew within a bank of outputs at the same voltage and with equal load conditions.

NOTE 4: Defined as skew between outputs on different devices operating at the same supply voltage, same frequency, same temperature and with equal load conditions. Using the same type of inputs on each device, the outputs are measured at the differential crosspoints.

NOTE 5: Measured from the differential input crosspoint to the differential output crosspoint.



### Parameter Measurement Information

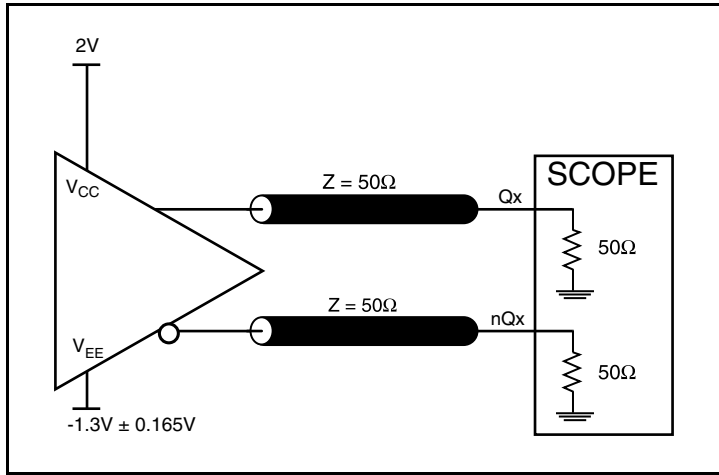

3.3V LVPECL Output Load Test Circuit

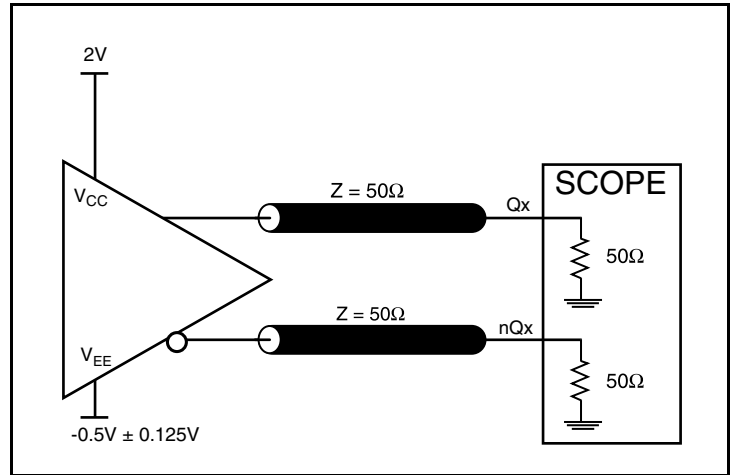

2.5V LVPECL Output Load Test Circuit

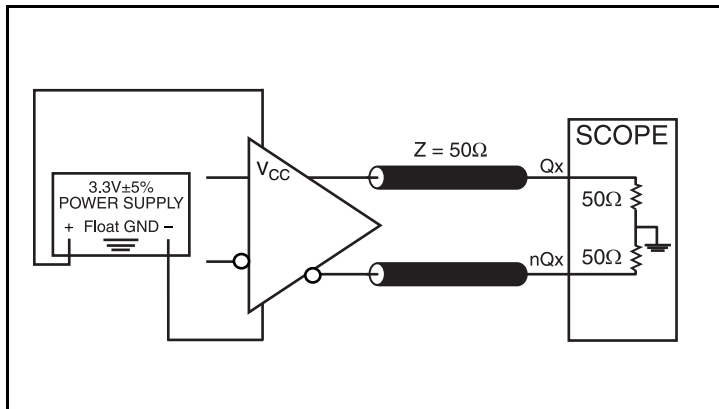

3.3V LVDS Output Load Test Circuit

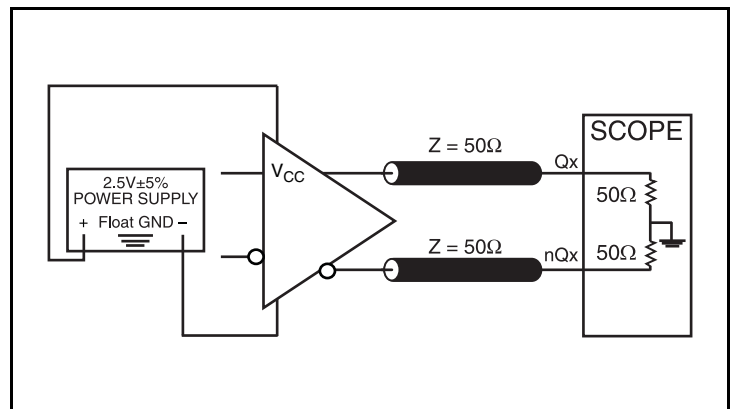

2.5V LVDS Output Load Test Circuit

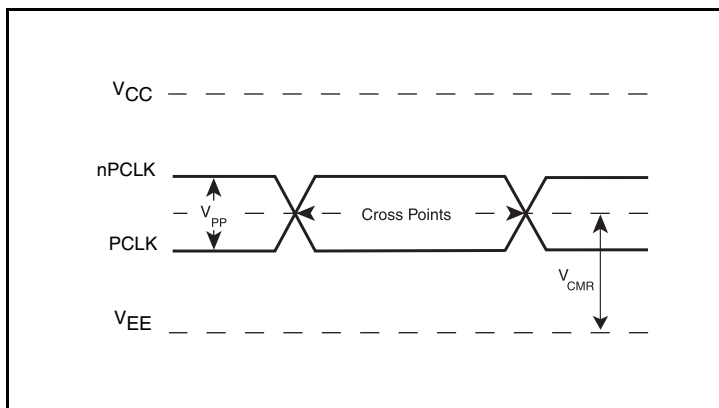

Differential Input Levels

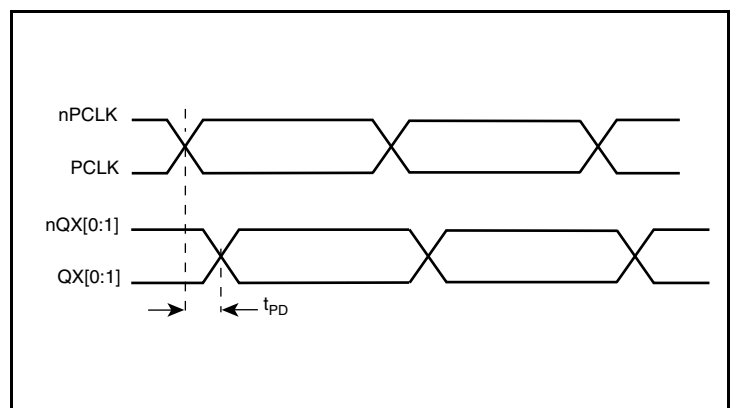

Propagation Delay

### Parameter Measurement Information, continued

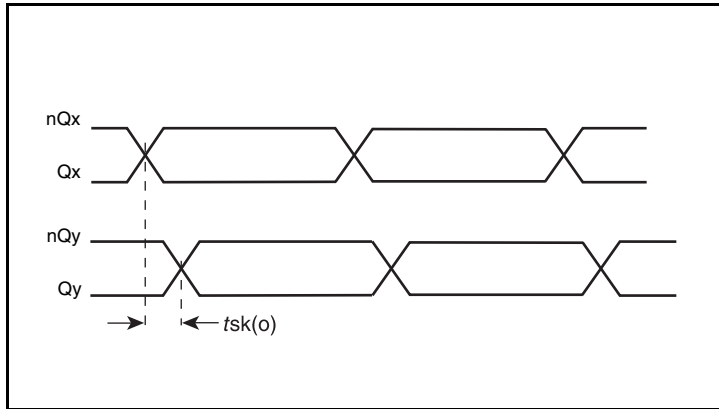

**Output Skew**

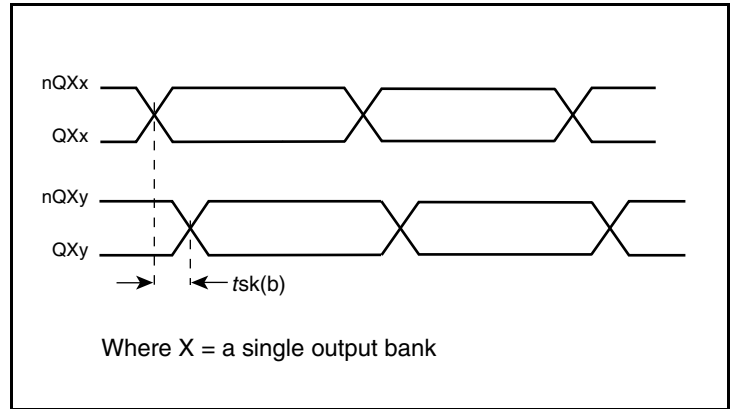

Where X = a single output bank

**Bank Skew**

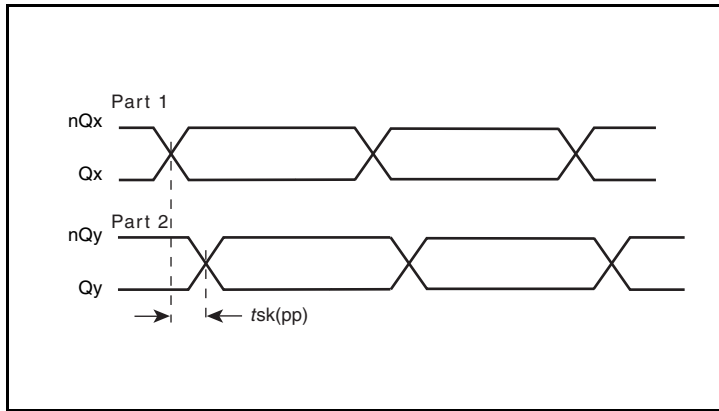

**Part-to-Part Skew**

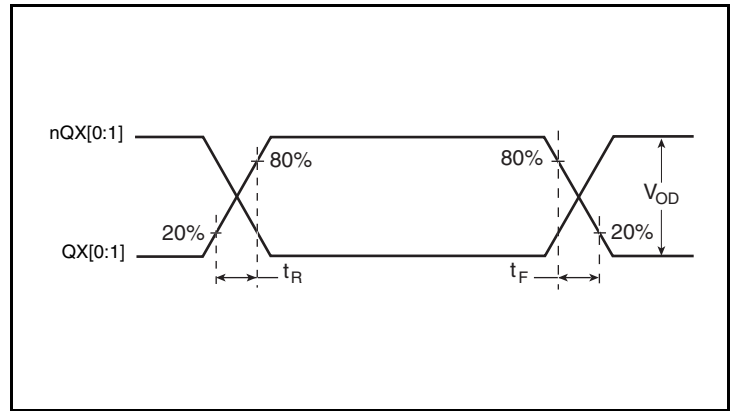

**LVDS Output Rise/Fall Time**

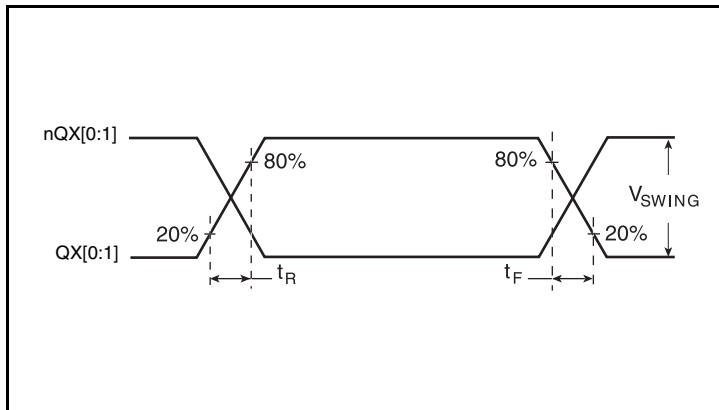

**LVPECL Output Rise/Fall Time**

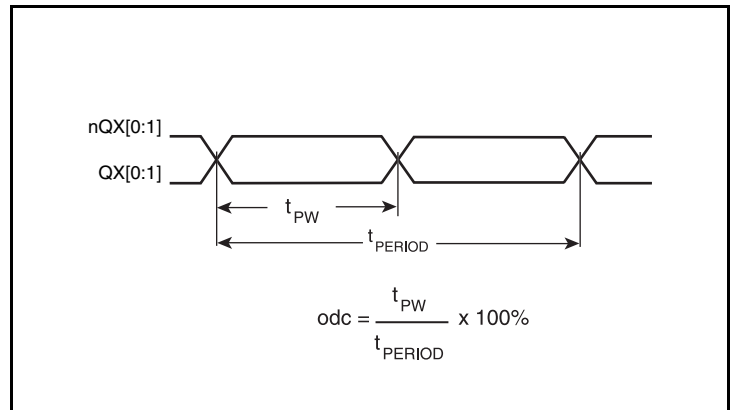

$$odc = \frac{t_{PW}}{t_{PERIOD}} \times 100\%$$

**Output Duty Cycle/Pulse Width/Period**

## Parameter Measurement Information, continued

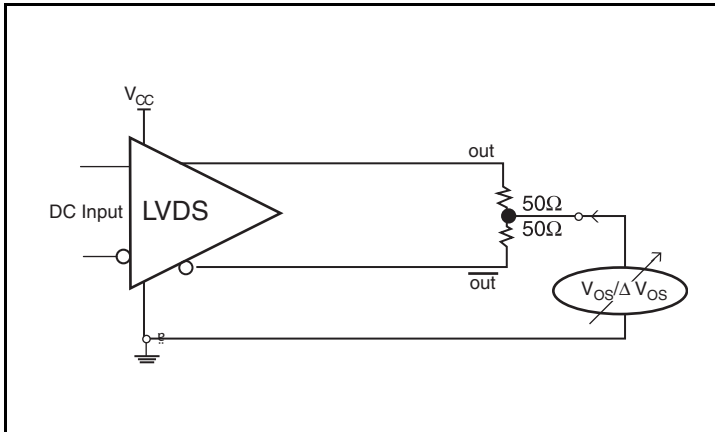

Offset Voltage Setup

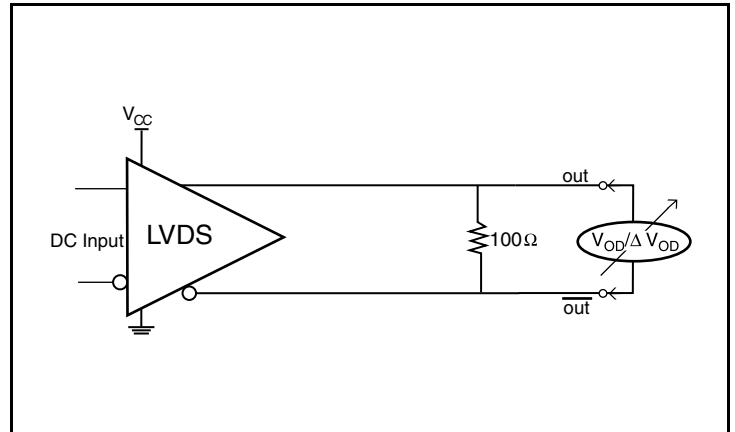

Differential Output Voltage Setup

## Applications Information

### Recommendations for Unused Input and Output Pins

#### Inputs:

##### LVC MOS Control Pins

All control pins have internal pulldowns; additional resistance is not required but can be added for additional protection. A 1kΩ resistor can be used.

#### Outputs:

##### LVPECL Outputs

Any unused LVPECL output pairs can be left floating. We recommend that there is no trace attached. Both sides of the differential output pair should either be left floating or terminated.

##### LVDS Outputs

All unused LVDS output pairs can be either left floating or terminated with 100Ω across. If they are left floating, there should be no trace attached.

##### LVC MOS Outputs

The unused LVC MOS output can be left floating. There should be no trace attached.

## Wiring the Differential Input to Accept Single-Ended Levels

Figure 2 shows how a differential input can be wired to accept single ended levels. The reference voltage  $V_1 = V_{CC}/2$  is generated by the bias resistors R1 and R2. The bypass capacitor (C1) is used to help filter noise on the DC bias. This bias circuit should be located as close to the input pin as possible. The ratio of R1 and R2 might need to be adjusted to position the  $V_1$  in the center of the input voltage swing. For example, if the input clock swing is 2.5V and  $V_{CC} = 3.3V$ , R1 and R2 value should be adjusted to set  $V_1$  at 1.25V. The values below are for when both the single ended swing and  $V_{CC}$  are at the same voltage. This configuration requires that the sum of the output impedance of the driver ( $R_o$ ) and the series resistance ( $R_s$ ) equals the transmission line impedance. In addition, matched termination at the input will attenuate the signal in half. This can be done in one of two ways. First, R3 and R4 in parallel should equal the transmission line impedance.

For most 50Ω applications, R3 and R4 can be 100Ω. The values of the resistors can be increased to reduce the loading for slower and weaker LVCMOS driver. When using single-ended signaling, the noise rejection benefits of differential signaling are reduced. Even though the differential input can handle full rail LVCMOS signaling, it is recommended that the amplitude be reduced. The datasheet specifies a lower differential amplitude, however this only applies to differential signals. For single-ended applications, the swing can be larger, however  $V_{IL}$  cannot be less than -0.3V and  $V_{IH}$  cannot be more than  $V_{CC} + 0.3V$ . Though some of the recommended components might not be used, the pads should be placed in the layout. They can be utilized for debugging purposes. The datasheet specifications are characterized and guaranteed by using a differential signal.

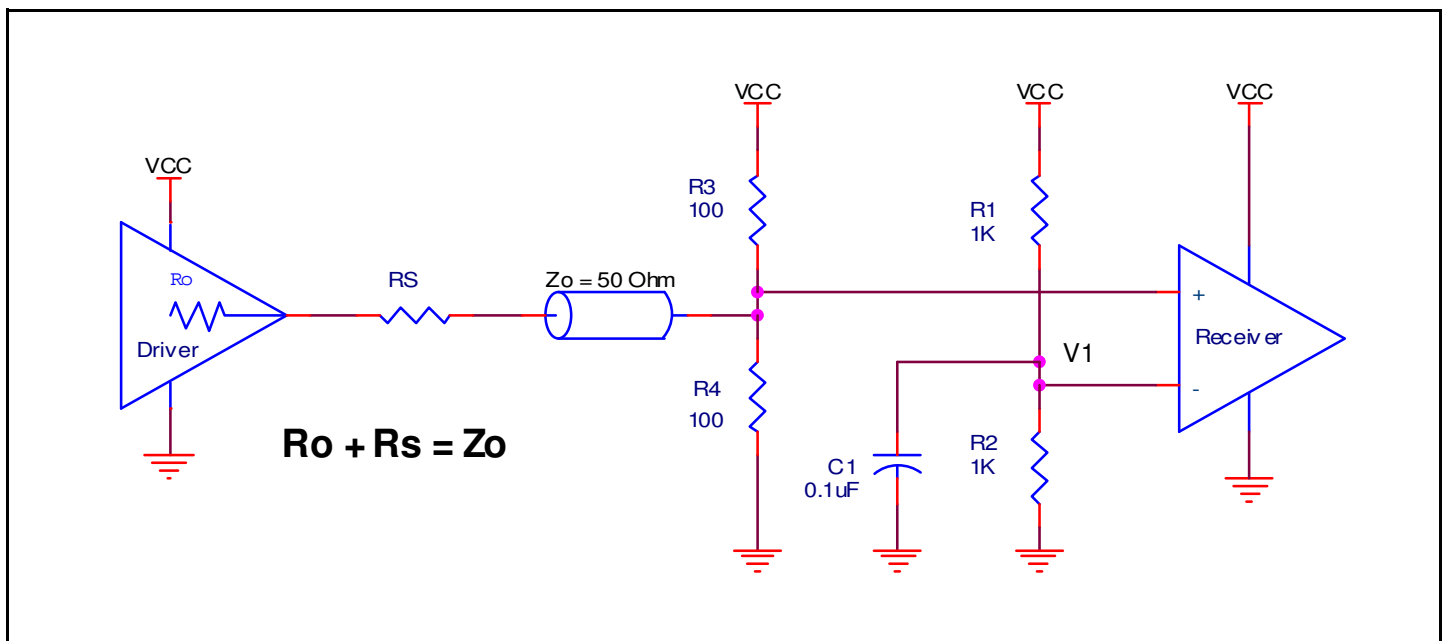
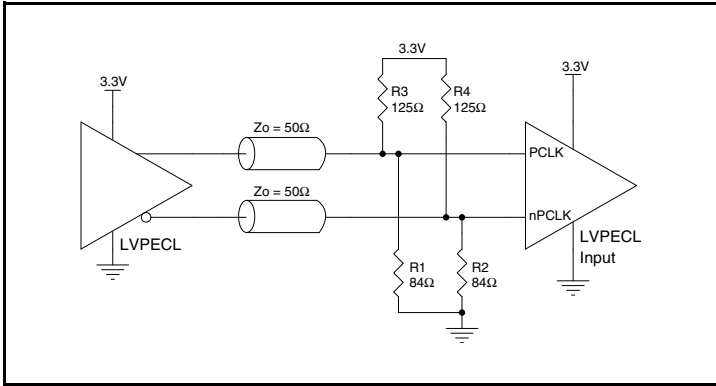

Figure 2. Recommended Schematic for Wiring a Differential Input to Accept Single-ended Levels

### 3.3V LVPECL Clock Input Interface

The PCLK/nPCLK accepts LVPECL, LVDS and other differential signals. Both  $V_{SWING}$  and  $V_{OH}$  must meet the  $V_{PP}$  and  $V_{CMR}$  input requirements. *Figures 3A to 3C* show interface examples for the PCLK/nPCLK input driven by the most common driver types. The input in-

terfaces suggested here are examples only. If the driver is from another vendor, use their termination recommendation. Please consult with the vendor of the driver component to confirm the driver termination requirements.



**Figure 3A. PCLK/nPCLK Input Driven by a 3.3V LVPECL Driver**

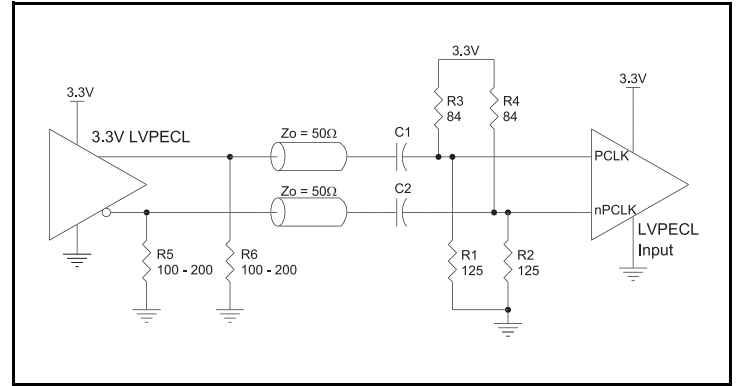

**Figure 3B. PCLK/nPCLK Input Driven by a 3.3V LVPECL Driver with AC Couple**

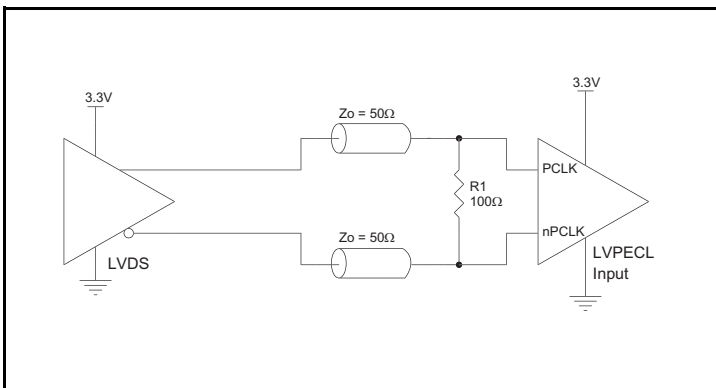
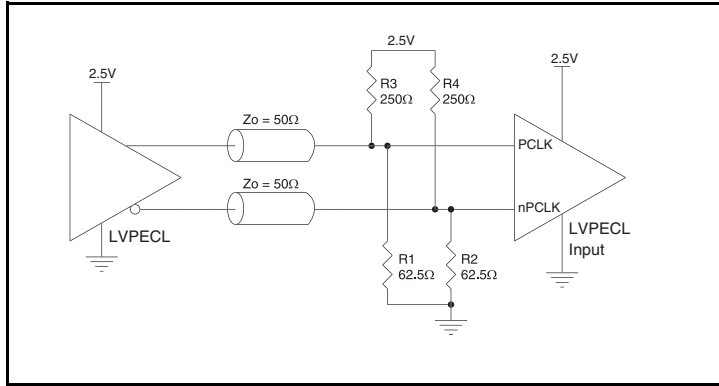

**Figure 3C. PCLK/nPCLK Input Driven by a 3.3V LVDS Driver**

### 2.5V LVPECL Clock Input Interface

The PCLK /nPCLK accepts LVPECL, LVDS and other differential signals. Both  $V_{SWING}$  and  $V_{OH}$  must meet the  $V_{PP}$  and  $V_{CMR}$  input requirements. Figures 4A to 4C show interface examples for the PCLK/nPCLK input driven by the most common driver types. The input in-

terfaces suggested here are examples only. If the driver is from another vendor, use their termination recommendation. Please consult with the vendor of the driver component to confirm the driver termination requirements.



**Figure 4A. PCLK/nPCLK Input Driven by a 2.5V LVPECL Driver**

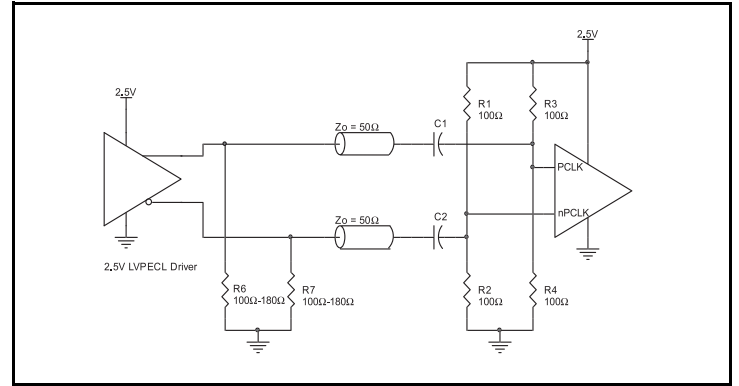

**Figure 4B. PCLK/nPCLK Input Driven by a 2.5V LVPECL Driver with AC Couple**

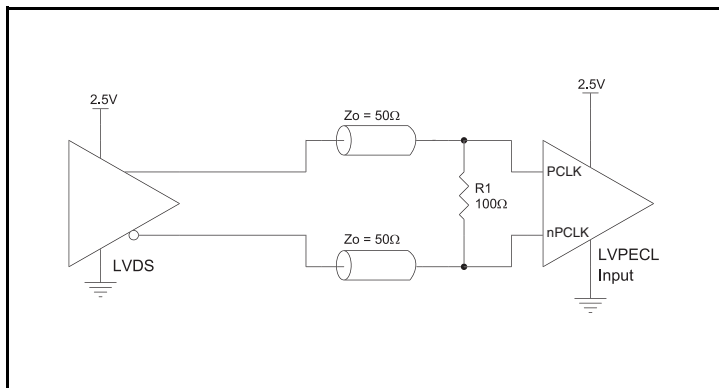
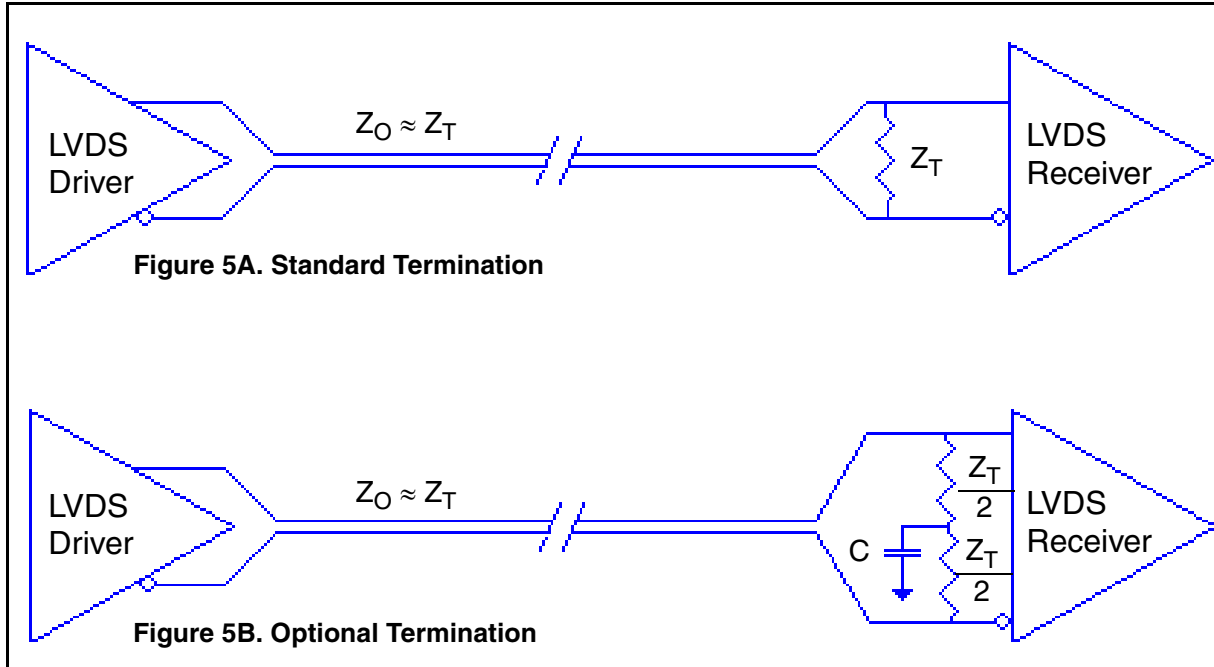

**Figure 4C. PCLK/nPCLK Input Driven by a 2.5V LVDS Driver**

## LVDS Driver Termination

For a general LVDS interface, the recommended value for the termination impedance ( $Z_T$ ) is between  $90\Omega$  and  $132\Omega$ . The actual value should be selected to match the differential impedance ( $Z_0$ ) of your transmission line. A typical point-to-point LVDS design uses a  $100\Omega$  parallel resistor at the receiver and a  $100\Omega$  differential transmission-line environment. In order to avoid any transmission-line reflection issues, the components should be surface mounted and must be placed as close to the receiver as possible. IDT offers a full line of LVDS compliant devices with two types of output structures: current source and voltage source. The

standard termination schematic as shown in *Figure 5A* can be used with either type of output structure. *Figure 5B*, which can also be used with both output types, is an optional termination with center tap capacitance to help filter common mode noise. The capacitor value should be approximately  $50\text{pF}$ . If using a non-standard termination, it is recommended to contact IDT and confirm if the output structure is current source or voltage source type. In addition, since these outputs are LVDS compatible, the input receiver's amplitude and common-mode input range should be verified for compatibility with the output.



### LVDS Termination

### Termination for 3.3V LVPECL Outputs

The clock layout topology shown below is a typical termination for LVPECL outputs. The two different layouts mentioned are recommended only as guidelines.

The differential outputs are low impedance follower outputs that generate ECL/LVPECL compatible outputs. Therefore, terminating resistors (DC current path to ground) or current sources must be used for

functionality. These outputs are designed to drive 50Ω transmission lines. Matched impedance techniques should be used to maximize operating frequency and minimize signal distortion. *Figures 6A and 6B* show two different layouts which are recommended only as guidelines. Other suitable clock layouts may exist and it would be recommended that the board designers simulate to guarantee compatibility across all printed circuit and clock component process variations.

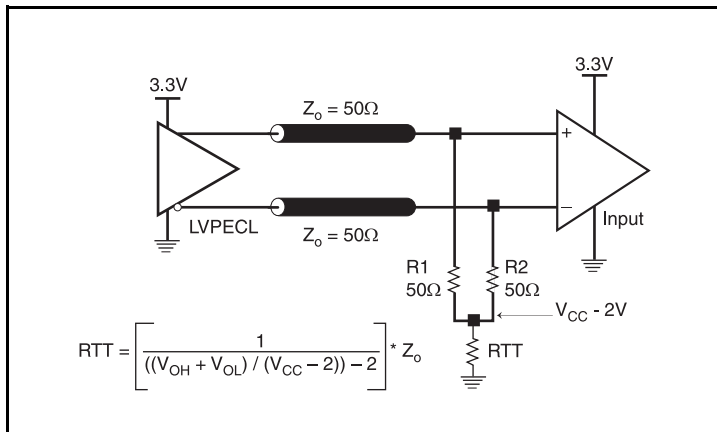

Figure 6A. 3.3V LVPECL Output Termination

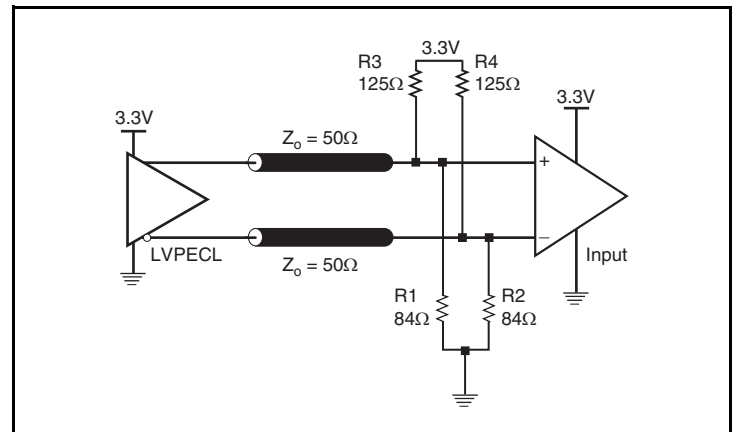

Figure 6B. 3.3V LVPECL Output Termination



### Termination for 2.5V LVPECL Outputs

Figure 7A and Figure 7B show examples of termination for 2.5V LVPECL driver. These terminations are equivalent to terminating  $50\Omega$  to  $V_{CC} - 2V$ . For  $V_{CC} = 2.5V$ , the  $V_{CC} - 2V$  is very close to ground

level. The R3 in Figure 7B can be eliminated and the termination is shown in Figure 7C.

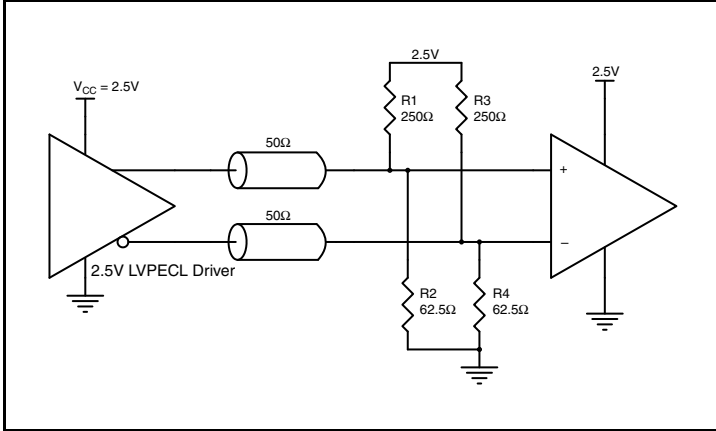

Figure 7A. 2.5V LVPECL Driver Termination Example

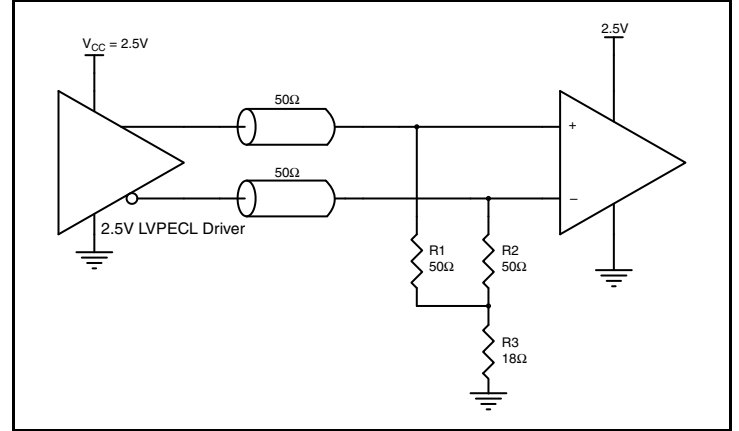

Figure 7B. 2.5V LVPECL Driver Termination Example

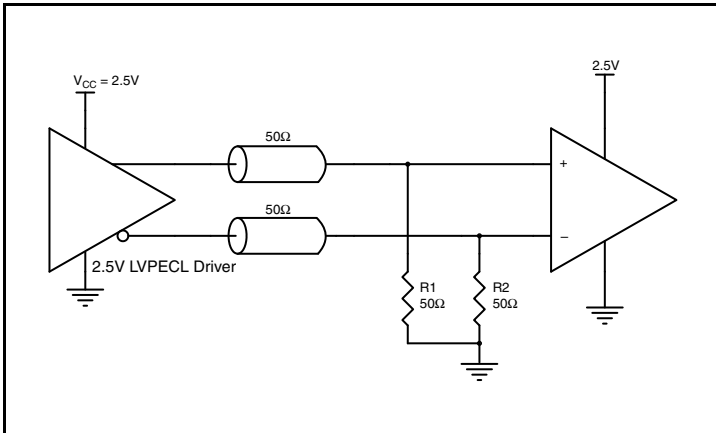

Figure 7C. 2.5V LVPECL Driver Termination Example

## VFQFN EPAD Thermal Release Path

In order to maximize both the removal of heat from the package and the electrical performance, a land pattern must be incorporated on the Printed Circuit Board (PCB) within the footprint of the package corresponding to the exposed metal pad or exposed heat slug on the package, as shown in *Figure 8*. The solderable area on the PCB, as defined by the solder mask, should be at least the same size/shape as the exposed pad/slug area on the package to maximize the thermal/electrical performance. Sufficient clearance should be designed on the PCB between the outer edges of the land pattern and the inner edges of pad pattern for the leads to avoid any shorts.

While the land pattern on the PCB provides a means of heat transfer and electrical grounding from the package to the board through a solder joint, thermal vias are necessary to effectively conduct from the surface of the PCB to the ground plane(s). The land pattern must be connected to ground through these vias. The vias act as “heat pipes”. The number of vias (i.e. “heat pipes”) are application specific and de-

pendent upon the package power dissipation as well as electrical conductivity requirements. Thus, thermal and electrical analysis and/or testing are recommended to determine the minimum number needed. Maximum thermal and electrical performance is achieved when an array of vias is incorporated in the land pattern. It is recommended to use as many vias connected to ground as possible. It is also recommended that the via diameter should be 12 to 13mils (0.30 to 0.33mm) with 1oz copper via barrel plating. This is desirable to avoid any solder wicking inside the via during the soldering process which may result in voids in solder between the exposed pad/slug and the thermal land. Precautions should be taken to eliminate any solder voids between the exposed heat slug and the land pattern. Note: These recommendations are to be used as a guideline only. For further information, please refer to the Application Note on the Surface Mount Assembly of Amkor’s Thermally/ Electrically Enhance Leadframe Base Package, Amkor Technology.

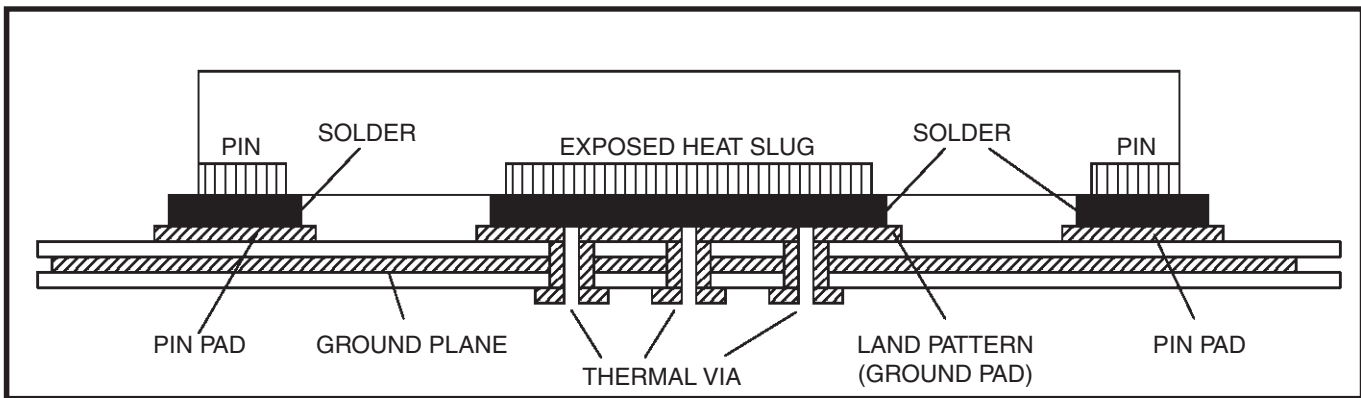

**Figure 8. P.C. Assembly for Exposed Pad Thermal Release Path – Side View (drawing not to scale)**

## 3.3V LVDS Power Considerations

This section provides information on power dissipation and junction temperature for the IDT8T79S838-08I. Equations and example calculations are also provided.

### 1. Power Dissipation.

The total power dissipation for the IDT8T79S838-08I is the sum of the core power plus the power dissipated due to the load. The following is the power dissipation for  $V_{CC} = 3.3V + 5\% = 3.465V$ , which gives worst case results.

- Power (core)<sub>MAX</sub> =  $V_{CC\_MAX} * I_{CC\_MAX} = 3.465V * 235mA = \mathbf{814.3mW}$

### 2. Junction Temperature.

Junction temperature,  $T_j$ , is the temperature at the junction of the bond wire and bond pad directly affects the reliability of the device. The maximum recommended junction temperature is 125°C. Limiting the internal transistor junction temperature,  $T_j$ , to 125°C ensures that the bond wire and bond pad temperature remains below 125°C.

The equation for  $T_j$  is as follows:  $T_j = \theta_{JA} * Pd\_total + T_A$

$T_j$  = Junction Temperature

$\theta_{JA}$  = Junction-to-Ambient Thermal Resistance

$Pd\_total$  = Total Device Power Dissipation (example calculation is in section 1 above)

$T_A$  = Ambient Temperature

In order to calculate junction temperature, the appropriate junction-to-ambient thermal resistance  $\theta_{JA}$  must be used. Assuming no air flow and a multi-layer board, the appropriate value is 48.9°C/W per Table 6 below.

Therefore,  $T_j$  for an ambient temperature of 85°C with all outputs switching is:

$$85^\circ\text{C} + 0.814\text{W} * 48.9^\circ\text{C/W} = 124.8^\circ\text{C}. \text{ This is below the limit of } 125^\circ\text{C}.$$

This calculation is only an example.  $T_j$  will obviously vary depending on the number of loaded outputs, supply voltage, air flow and the type of board (multi-layer).

**Table 6. Thermal Resistance  $\theta_{JA}$  for 32-lead VFQFN Package**

Meters per Second	$\theta_{JA}$ by Velocity		
	0	1	2
Multi-Layer PCB, JEDEC Standard Test Boards	48.9°C/W	42°C/W	39.4°C/W

## 3.3V LVPECL Power Considerations

This section provides information on power dissipation and junction temperature for the IDT8T79S838-08I, for all outputs that are configured to LVPECL. Equations and example calculations are also provided.

### 1. Power Dissipation.

The total power dissipation for the IDT8T79S838-08I is the sum of the core power plus the power dissipated due to loading. The following is the power dissipation for  $V_{CC} = 3.3V + 5\% = 3.465V$ , which gives worst case results.

NOTE: Please refer to Section 3 for details on calculating power dissipated due to loading.

- Power (core)<sub>MAX</sub> =  $V_{CC\_MAX} * I_{EE\_MAX} = 3.465V * 135mA = 467.8mW$
- Power (outputs)<sub>MAX</sub> = **31.55mW/Loaded Output pair**  
If all outputs are loaded, the total power is  $8 * 31.55mW = 252.4mW$

**Total Power**<sub>MAX</sub> (3.465V, with all outputs switching) =  $467.8mW + 252.4mW = 720.2mW$

### 2. Junction Temperature.

Junction temperature,  $T_j$ , is the temperature at the junction of the bond wire and bond pad directly affects the reliability of the device. The maximum recommended junction temperature is 125°C. Limiting the internal transistor junction temperature,  $T_j$ , to 125°C ensures that the bond wire and bond pad temperature remains below 125°C.

The equation for  $T_j$  is as follows:  $T_j = \theta_{JA} * Pd\_total + T_A$

$T_j$  = Junction Temperature

$\theta_{JA}$  = Junction-to-Ambient Thermal Resistance

$Pd\_total$  = Total Device Power Dissipation (example calculation is in section 1 above)

$T_A$  = Ambient Temperature

In order to calculate junction temperature, the appropriate junction-to-ambient thermal resistance  $\theta_{JA}$  must be used. Assuming no airflow and a multi-layer board, the appropriate value is 48.9°C/W per Table 7 below.

Therefore,  $T_j$  for an ambient temperature of 85°C with all outputs switching is:

$$85^\circ\text{C} + 0.720\text{W} * 48.9^\circ\text{C/W} = 120.2^\circ\text{C}. \text{ This is below the limit of } 125^\circ\text{C}.$$

This calculation is only an example.  $T_j$  will obviously vary depending on the number of loaded outputs, supply voltage, air flow and the type of board (multi-layer).

**Table 7. Thermal Resistance  $\theta_{JA}$  for 32-lead VFQFN Package**

$\theta_{JA}$ by Velocity			
Meters per Second	0	1	2
Multi-Layer PCB, JEDEC Standard Test Boards	48.9°C/W	42°C/W	39.4°C/W

### 3. Calculations and Equations.

The purpose of this section is to calculate the power dissipation for the LVPECL output pairs.

LVPECL output driver circuit and termination are shown in *Figure 9*.

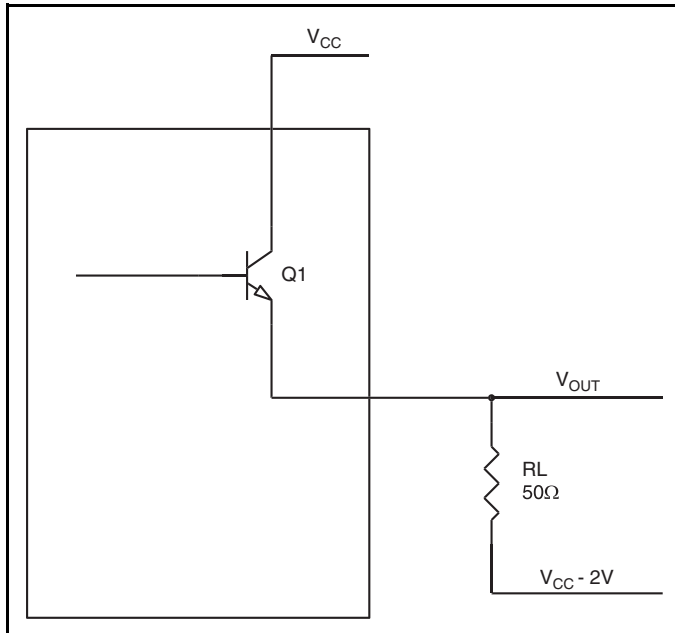

**Figure 9. LVPECL Driver Circuit and Termination**

To calculate power dissipation per output pair due to loading, use the following equations which assume a 50Ω load, and a termination voltage of  $V_{CC} - 2V$ .

- For logic high,  $V_{OUT} = V_{OH\_MAX} = V_{CC\_MAX} - 0.75V$   
( $V_{CC\_MAX} - V_{OH\_MAX}$ ) = **0.75V**
- For logic low,  $V_{OUT} = V_{OL\_MAX} = V_{CC\_MAX} - 1.6V$   
( $V_{CC\_MAX} - V_{OL\_MAX}$ ) = **1.6V**

$Pd\_H$  is power dissipation when the output drives high.

$Pd\_L$  is the power dissipation when the output drives low.

$$Pd\_H = [(V_{OH\_MAX} - (V_{CC\_MAX} - 2V))/R_L] * (V_{CC\_MAX} - V_{OH\_MAX}) = [(2V - (V_{CC\_MAX} - V_{OH\_MAX}))/R_L] * (V_{CC\_MAX} - V_{OH\_MAX}) = [(2V - 0.75V)/50\Omega] * 0.75V = \mathbf{18.75mW}$$

$$Pd\_L = [(V_{OL\_MAX} - (V_{CC\_MAX} - 2V))/R_L] * (V_{CC\_MAX} - V_{OL\_MAX}) = [(2V - (V_{CC\_MAX} - V_{OL\_MAX}))/R_L] * (V_{CC\_MAX} - V_{OL\_MAX}) = [(2V - 1.6V)/50\Omega] * 1.6V = \mathbf{12.80mW}$$

$$\text{Total Power Dissipation per output pair} = Pd\_H + Pd\_L = \mathbf{31.55mW}$$

## Reliability Information

**Table 8.  $\theta_{JA}$  vs. Air Flow Table for a 32-lead VFQFN Package**

$\theta_{JA}$ vs. Air Flow			
Meters per Second	<b>0</b>	<b>1</b>	<b>2</b>
Multi-Layer PCB, JEDEC Standard Test Boards	48.9°C/W	42.0°C/W	39.4°C/W

## Transistor Count

The transistor count for IDT8T79S838-08I is: 2618

# 32 Lead VFQFN Package Outline and Package Dimensions

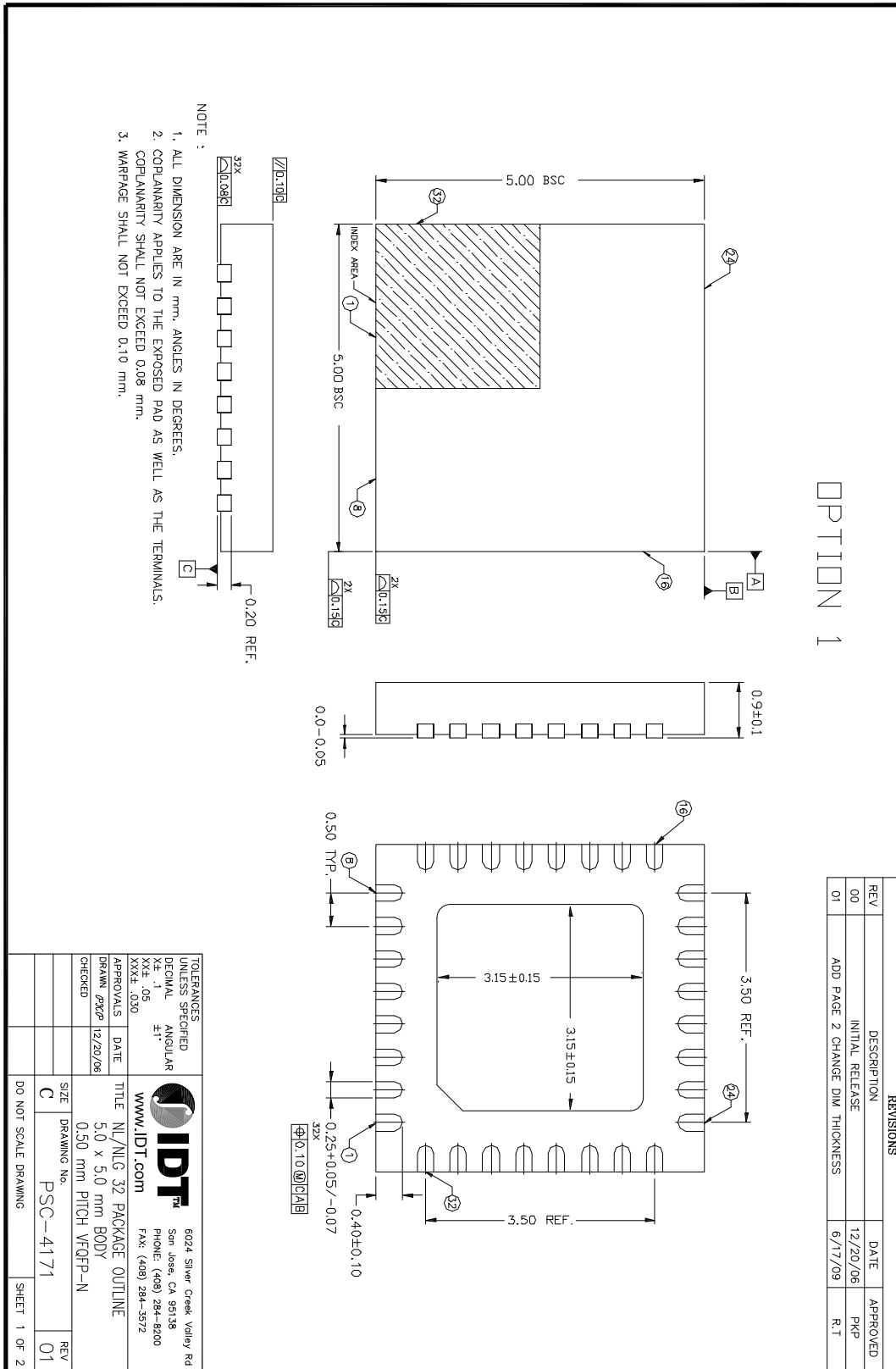

## Ordering Information

**Table 9. Ordering Information**

<b>Part/Order Number</b>	<b>Marking</b>	<b>Package</b>	<b>Shipping Packaging</b>	<b>Temperature</b>
8T79S838-08NLGI	IDT8T79S838-08NLGI	"Lead-Free" 32 Lead VFQFN	Tray	-40°C to 85°C
8T79S838-08NLGI8	IDT8T79S838-08NLGI	"Lead-Free" 32 Lead VFQFN	Tape & Reel	-40°C to 85°C



## We've Got Your Timing Solution



6024 Silver Creek Valley Road  
San Jose, California 95138

**Sales**  
800-345-7015 (inside USA)  
+408-284-8200 (outside USA)  
Fax: 408-284-2775  
[www.IDT.com/go/contactIDT](http://www.IDT.com/go/contactIDT)

**Technical Support**  
[netcom@idt.com](mailto:netcom@idt.com)  
+480-763-2056

DISCLAIMER Integrated Device Technology, Inc. (IDT) and its subsidiaries reserve the right to modify the products and/or specifications described herein at any time and at IDT's sole discretion. All information in this document, including descriptions of product features and performance, is subject to change without notice. Performance specifications and the operating parameters of the described products are determined in the independent state and are not guaranteed to perform the same way when installed in customer products. The information contained herein is provided without representation or warranty of any kind, whether express or implied, including, but not limited to, the suitability of IDT's products for any particular purpose, an implied warranty of merchantability, or non-infringement of the intellectual property rights of others. This document is presented only as a guide and does not convey any license under intellectual property rights of IDT or any third parties.

IDT's products are not intended for use in applications involving extreme environmental conditions or in life support systems or similar devices where the failure or malfunction of an IDT product can be reasonably expected to significantly affect the health or safety of users. Anyone using an IDT product in such a manner does so at their own risk, absent an express, written agreement by IDT.

Integrated Device Technology, IDT and the IDT logo are registered trademarks of IDT. Other trademarks and service marks used herein, including protected names, logos and designs, are the property of IDT or their respective third party owners.

Copyright 2014. All rights reserved.