

PLEASE CHECK WWW.MOLEX.COM FOR LATEST PART INFORMATION

Part Number: **0190730080**
Status: **Active**
Description: Avikrimp™ Ring Tongue Terminal for 14 to 16 AWG Wire, Stud Size 5/16", Length 27.36m (1.077"), Mylar Tape Carrier

Documents:

[Drawing \(PDF\)](#) [RoHS Certificate of Compliance \(PDF\)](#)

Agency Certification

CSA LR18689
 UL E32244

General

Product Family Ring and Spade Terminals
 Series [19073](#)
 Crimp Quality Equipment Yes
 Mil-Spec N/A
 Product Name Avikrimp™
 Type Ring

Physical

Barrel Type Closed
 Flammability 94V-0
 Insulation Nylon (PA)
 Material - Plating Mating Tin
 Packaging Type Adhesive Tape on Reel
 Plating min: Mating (µin) 100
 Plating min: Mating (µm) 2.5
 Plating min: Termination (µin) 100
 Plating min: Termination (µm) 2.5
 Stud Size 5/16" (M8)
 Wire Insulation Diameter 4.30mm (.170") max.
 Wire Size AWG 14, 16
 Wire Size mm² 1.00 - 2.60

Material Info

Old Part Number BB-825-56T

Reference - Drawing Numbers

Sales Drawing SD-19073-005

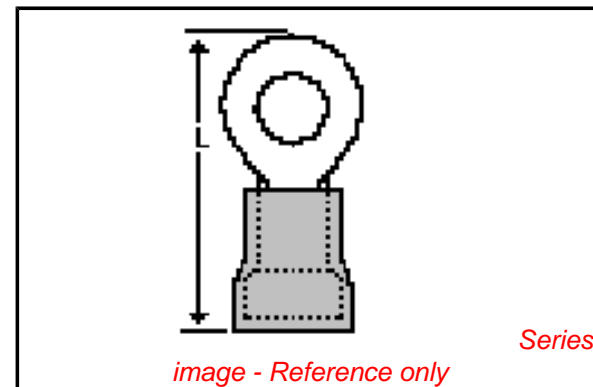

EU RoHS

ELV and RoHS Compliant
REACH SVHC
 Not Reviewed
Halogen-Free Status
Not Reviewed

China RoHS



Need more information on product environmental compliance?

Email productcompliance@molex.com
 For a multiple part number RoHS Certificate of Compliance, [click here](#)

Please visit the [Contact Us](#) section for any non-product compliance questions.

Search Parts in this Series

[19073Series](#)

Application Tooling | [FAQ](#)

Tooling specifications and manuals are found by selecting the products below. Crimp Height Specifications are then contained in the Application Tooling Specification document.

Global

Description	Product #
Crimp Dies for MTA-100 Tape Applicator used in 3BF Press, MTA-105 Tape Applicator used in TM-2000™ Press, and ATP-301 Air Crimping Press for Mylar Tape Mounted Terminals	0192880123
Mini-Mac™ Applicator	0638850400

This document was generated on 04/12/2010

PLEASE CHECK WWW.MOLEX.COM FOR LATEST PART INFORMATION

19073

MATERIAL NUMBER	ENG. NO.	MATERIAL NUMBER TAPE MOUNTED	ENG. NO.	STUD SIZE	"S" ±.005	"W" MAX	"C" MIN	"L" MAX
190730301	BB-818-14	190730058	BB-818-14T	14	.265 (6.73)	.544 (13.82)	.554 (14.07)	1.225 (31.12)
190730059	BB-818-38	190730060	BB-818-38T	38	.390 (9.91)			
190730061	BB-818-56	190730062	BB-818-56T	56	.328 (8.33)			
190730065	BB-823-04	190730066	BB-823-04T	04	.119 (3.02)	.270 (6.86)	.209 (5.31)	.770 (20.32)
190730067	BB-823-06	190730070	BB-823-06T	06	.146 (3.71)			
190730072	BB-823-08	190730073	BB-823-08T	08	.173 (4.39)	.477 (12.12)	.388 (9.86)	1.077 (27.36)
190730074	BB-825-10	190730075	BB-825-10T	10	.198 (5.03)			
190730076	BB-825-14	190730077	BB-825-14T	14	.265 (6.73)			
190730079	BB-825-56	190730080	BB-825-56T	56	.328 (8.33)			

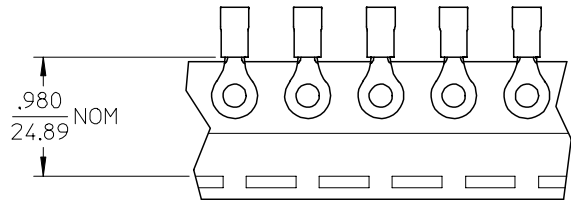
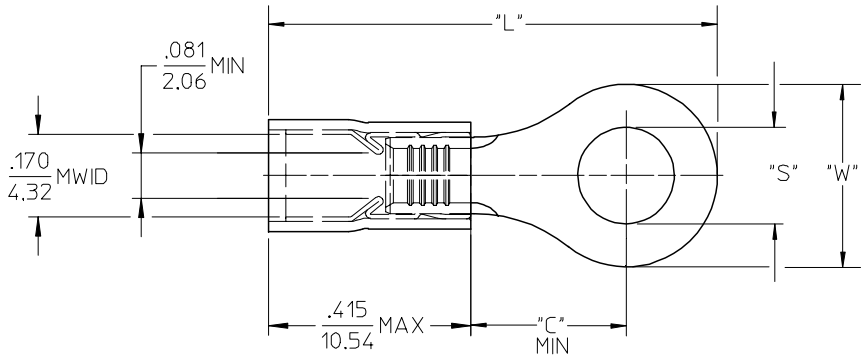

SALES DRAWING

- NOTES:
1. MATERIAL: COPPER (.031/0.79) THICK PLATING: ELECTROPLATE TIN
 2. FERRULE: TIN-PLATED BRASS
 3. INSULATION: BLUE NYLON
 4. MWID=MAXIMUM WIRE INSULATION DIA.
 5. ALL DIMENSIONS IN INCHES (MM).
 6. WIRE SIZE: 16-14 AWG
1.0-2.5 MM²

EC NO: ETC2004-0167 DRWN:DMYRICK 2004/03/31 CHKD:HBEITZEL 2004/04/01 APPR:RDEROSS 2004/04/01	QUALITY SYMBOLS	GENERAL TOLERANCES (UNLESS SPECIFIED)		SCALE 4:1	DESIGN UNITS INCH	THIRD ANGLE PROJECTION	REVISE ON CAD ONLY	
	DESCRIPTION ▼ = 0 ▽ = 0	mm	INCH	DIMENSION STYLE IN/MM		TITLE		
		4 PLACES	± ---	± ---	DRAWN BY DMYRICK	DATE 03/12/15	RING TONGUE TERMINAL AVIKRIMP, 800-SERIES 16-14 AWG	
		3 PLACES	± ---	± .005	CHECKED BY HBEITZEL	DATE 03/12/15	MOLEX INCORPORATED	
	2 PLACES	± 0.13	± .01	APPROVED BY RDEROSS	DATE 03/12/15	MATERIAL NO. SEE CHART	DOCUMENT NO. SD-19073-005	
	1 PLACE	± 0.25	± ---	DRAFT WHERE APPLICABLE MUST REMAIN WITHIN DIMENSIONS		SHEET NO. 1 OF 1		
	ANGULAR ± 1 °		THIS DRAWING CONTAINS INFORMATION THAT IS PROPRIETARY TO MOLEX INCORPORATED AND SHOULD NOT BE USED WITHOUT WRITTEN PERMISSION					